



IBM System z Technical Conference Dresden – Germany – May 5-9



VSAM Redirector Technology with Live Demo

Wilhelm Mild

z/VSE Solution Architect

zvse@de.ibm.com

15-March-2007

© 2008 IBM Corporation

Trademarks

The following are trademarks of the International Business Machines Corporation in the United States and / or other countries.

CICS*	IBM*	Virtual Image Facility
DB2*	IBM logo*	VM/ESA*
DB2 Connect	IMS	VSE/ESA
DB2 Universal Database	Intelligent Miner	z/VSE
e-business logo*	Multiprise*	VisualAge*
Enterprise Storage Server	MQSeries*	VTAM*
HiperSockets	OS/390*	WebSphere*
	S/390*	xSeries
	SNAP/SHOT*	z/Architecture
		z/VM
		z/VSE
		zSeries
		System z

* Registered trademarks of IBM Corporation

The following are trademarks or registered trademarks of other companies.

LINUX is a registered trademark of Linus Torvalds

Tivoli is a trademark of Tivoli Systems Inc.

Java and all Java-related trademarks and logos are trademarks of Sun Microsystems, Inc., in the United States and other countries

UNIX is a registered trademark of The Open Group in the United States and other countries.

Microsoft, Windows and Windows NT are registered trademarks of Microsoft Corporation.

SET and Secure Electronic Transaction are trademarks owned by SET Secure Electronic Transaction LLC.

Intel is a registered trademark of Intel Corporation.

A typical VSE environment today

- Various different servers (System z, System p, System i, System x, and others)
- VSAM data on VSE (some DB2 environments, some other databases)
- Relational databases on distributed platforms (DB2, Oracle, others)
- **Data exchange is primarily done via FTP**
- **Almost NO real time data access/exchange**

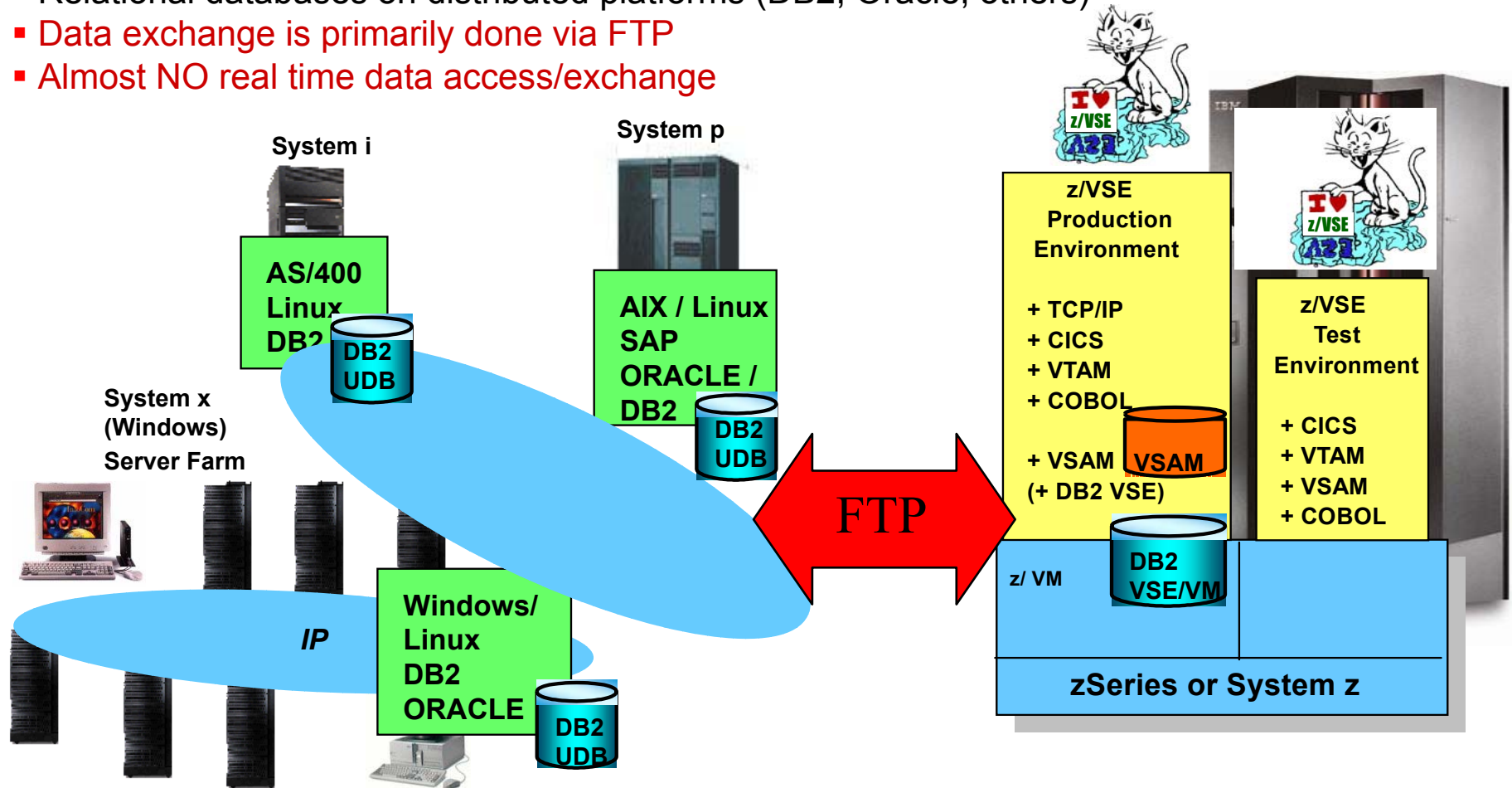

VSE/VSAM applications and data transfer today

- (1) disadvantages of FTP
 - a) NO real-time access/synchronization
 - b) data immediate out of sync, till next FTP
 - c) always the whole file is transferred
 - d) intermediate step – database loader needed
 - e) FTP is a stateless protocol – no guaranteed delivery
 - f) increased network traffic

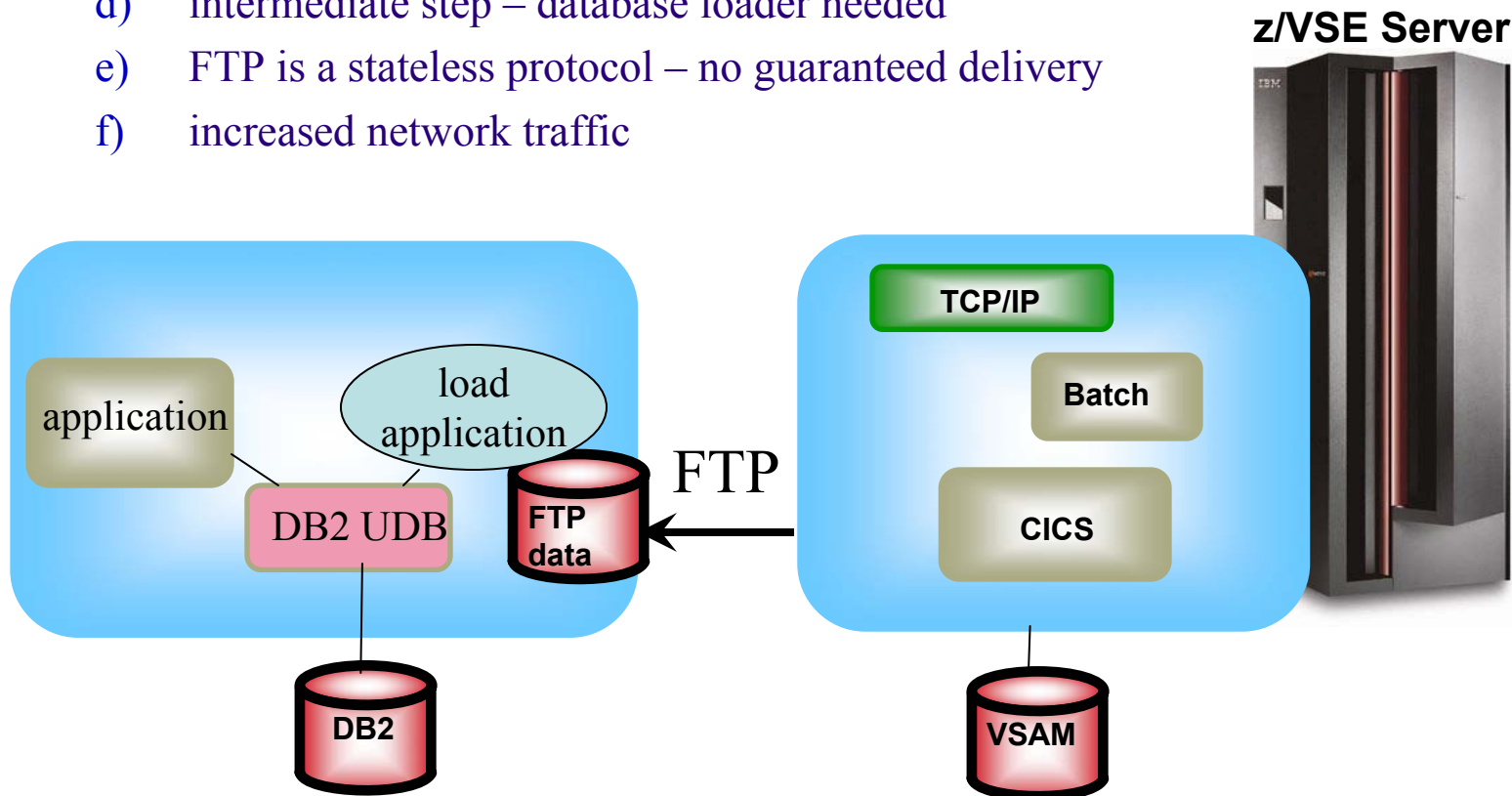

VSAM Programs with DB2 UDB on Linux on System z

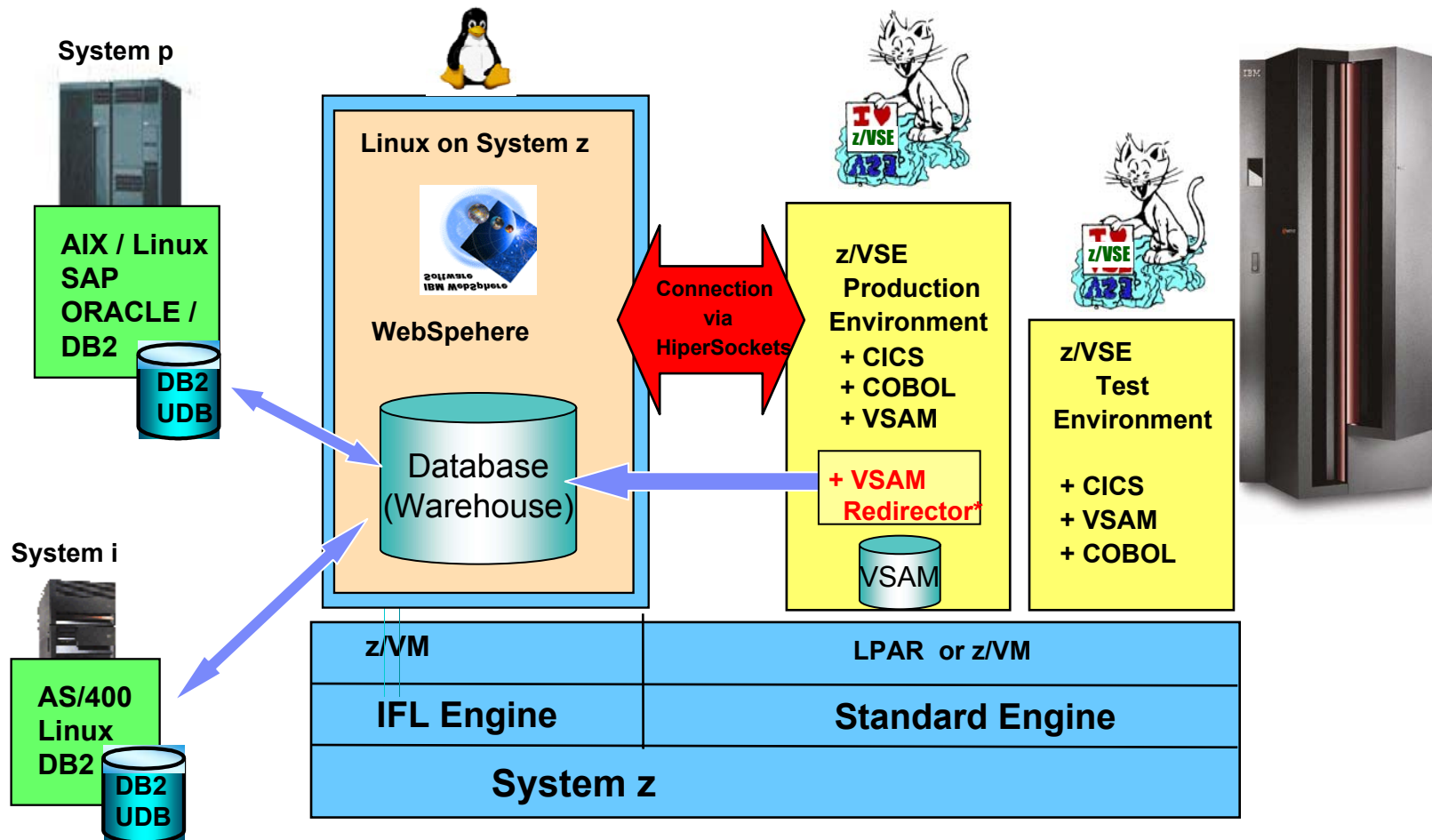

(*) VSAM Redirector – Common data store solution – with DB2 on Linux on zSeries Solutions without changes to VSAM programs

VSE/VSAM Redirector - functional view

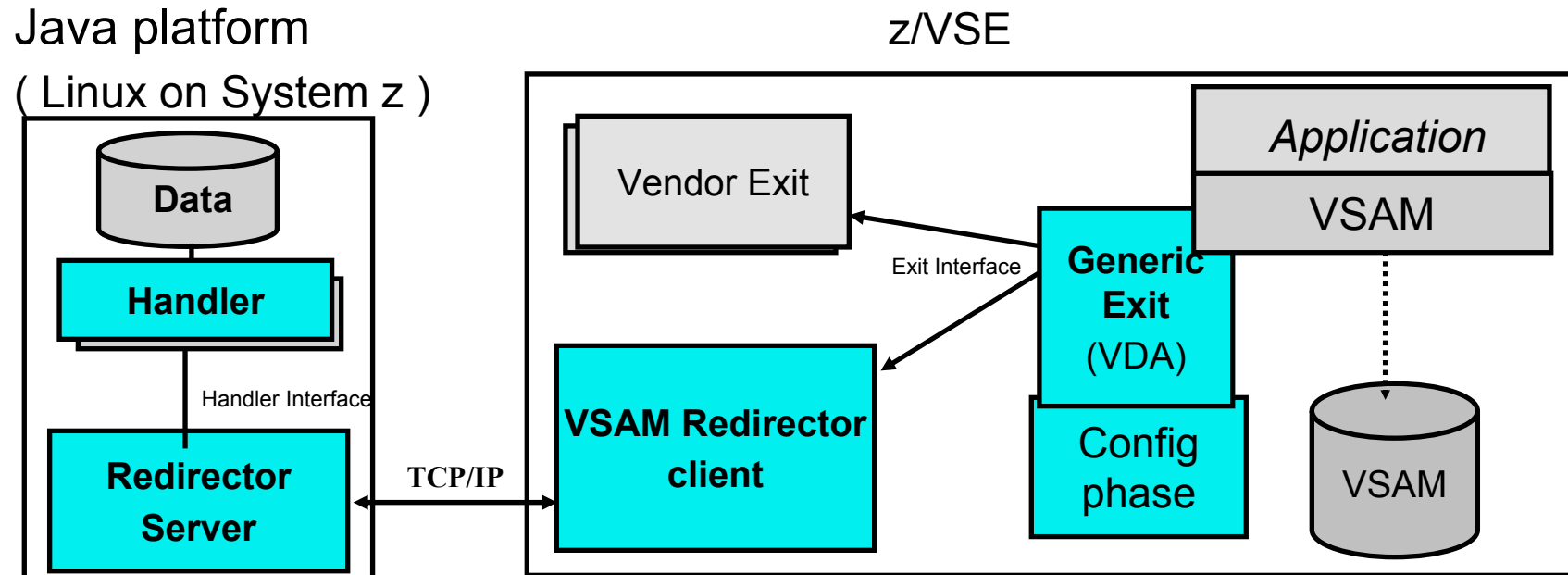

- ▶ **Redirector Components:**
 - ▶ **Generic Exit is based on VSAM Data Access Exit (VDA)**
 - ▶ **Config phase – contains the redirection properties**
 - ▶ **Redirector client (SVA phase)**
 - ▶ **Redirector server – manages the connections (Java component)**
 - ▶ **Handler – takes care of data processing (Javav component)**

VSAM Redirector – the Client

- **The Client**, Shipped in VSE phase **IESREDIR**
- Forwards all requests via TCP/IP socket to VSAM Redirector Server on a remote site
- **Important Parameter**
 - **OWNER=REDIRECTOR**
 - VSAM requests are executed by remote site only
 - VSAM does not execute the request
 - controlled by return code from IKQVEX01
 - Allows migrating VSAM data to a database without changing the VSAM programs
 - **OWNER=VSAM**
 - Both, VSAM and remote site executes the request
 - Allows synchronization of VSAM and database without changing the VSAM programs

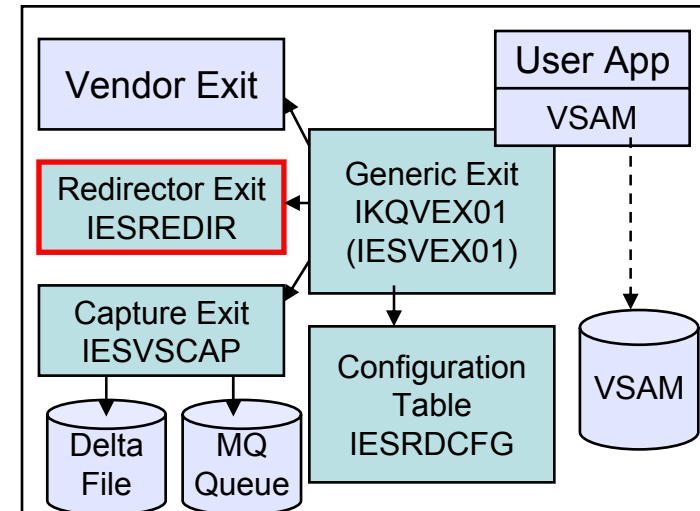

VSAM Redirector – Configuration Table

- Gets assembled as VSE PHASE
 - Does not contain any executable code, just a table

```
IESRDENT CATALOG='MY.VSAM.CATALOG',
         CLUSTER='MY.VSAM.CLUSTER1',
         EXIT='IESREDIR',
         OWNER=REDIRECTOR,
         IP='1.2.3.4',
         HANDLER='com.ibm.vse.db2handler.DB2Handler',
         OPTIONS='dburl=jdbc:db2:database;dbuser=user;
                 mactable=mactable;map=mapname;
                 dbpassword=password;dbtable=table,
```

```
IESRDENT CATALOG='VSESP.USER.CATALOG',
         CLUSTER='MY.TEST.CLUSTER2',
         EXIT='IESVSCAP',
         MODE=JOURNALING,
         DELTADD='DELTAFI',
         DELTATYPE=KSDS,
         SHARE=ENDREQ,
         ORIGIN='TEST2'
```

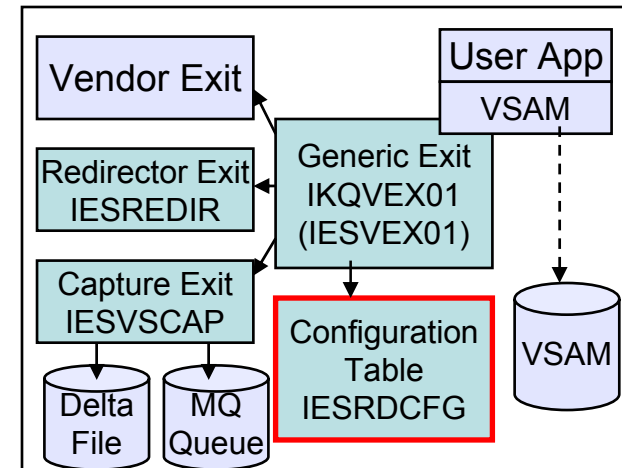

The flavors of VSAM redirector

- (1) Remote processing - Real time VSAM access to remote**
 - a) Remote only processing to DB2 (no VSAM access anymore)**
 - b) Synchronization (two phase commit of VSAM and DB2)**

- (2) Capture - VSE local data processing in addition to VSAM**
 - a) Capture Exit for VSAM processing**
 - b) MQ Exit and MQ Series solutions**

VSE/VSAM applications (without any change), access remote relational databases

- (1) Real time access VSAM to DB2
 - a) synchronization (two phase commit of VSAM and DB2)
 - b) Real time push of VSAM data to DB2

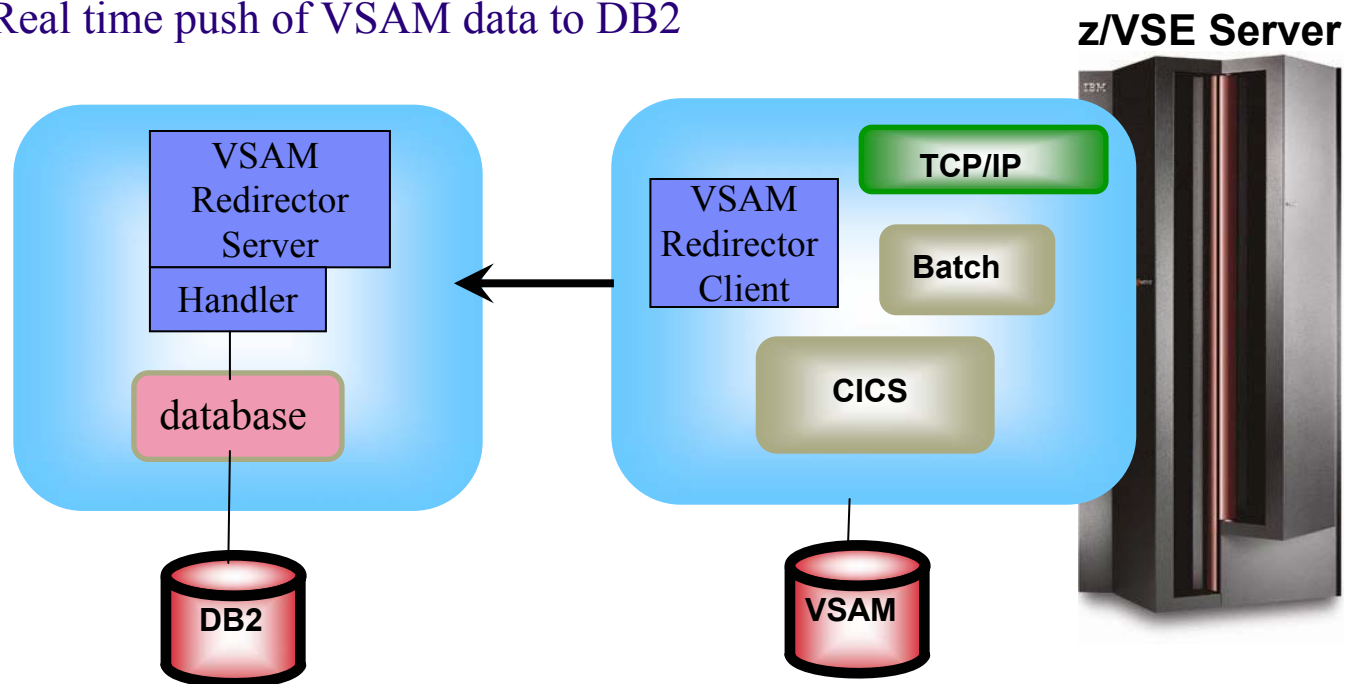

VSE/VSAM applications (without any change), access remote relational databases

- (1) Real time access VSAM to DB2
 - a) synchronization (two phase commit of VSAM and DB2)
 - b) Real time push of VSAM data to DB2

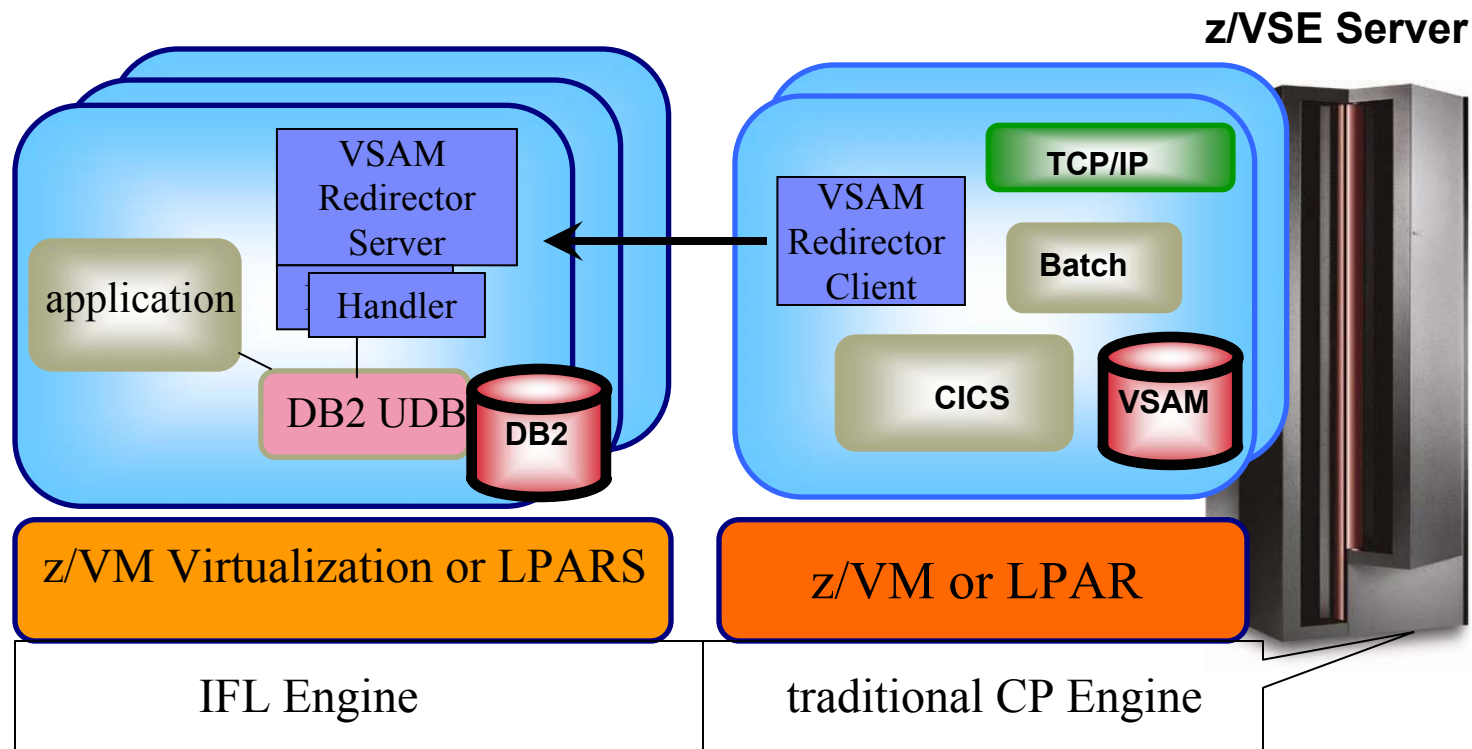

VSE/VSAM applications, access remote relational databases

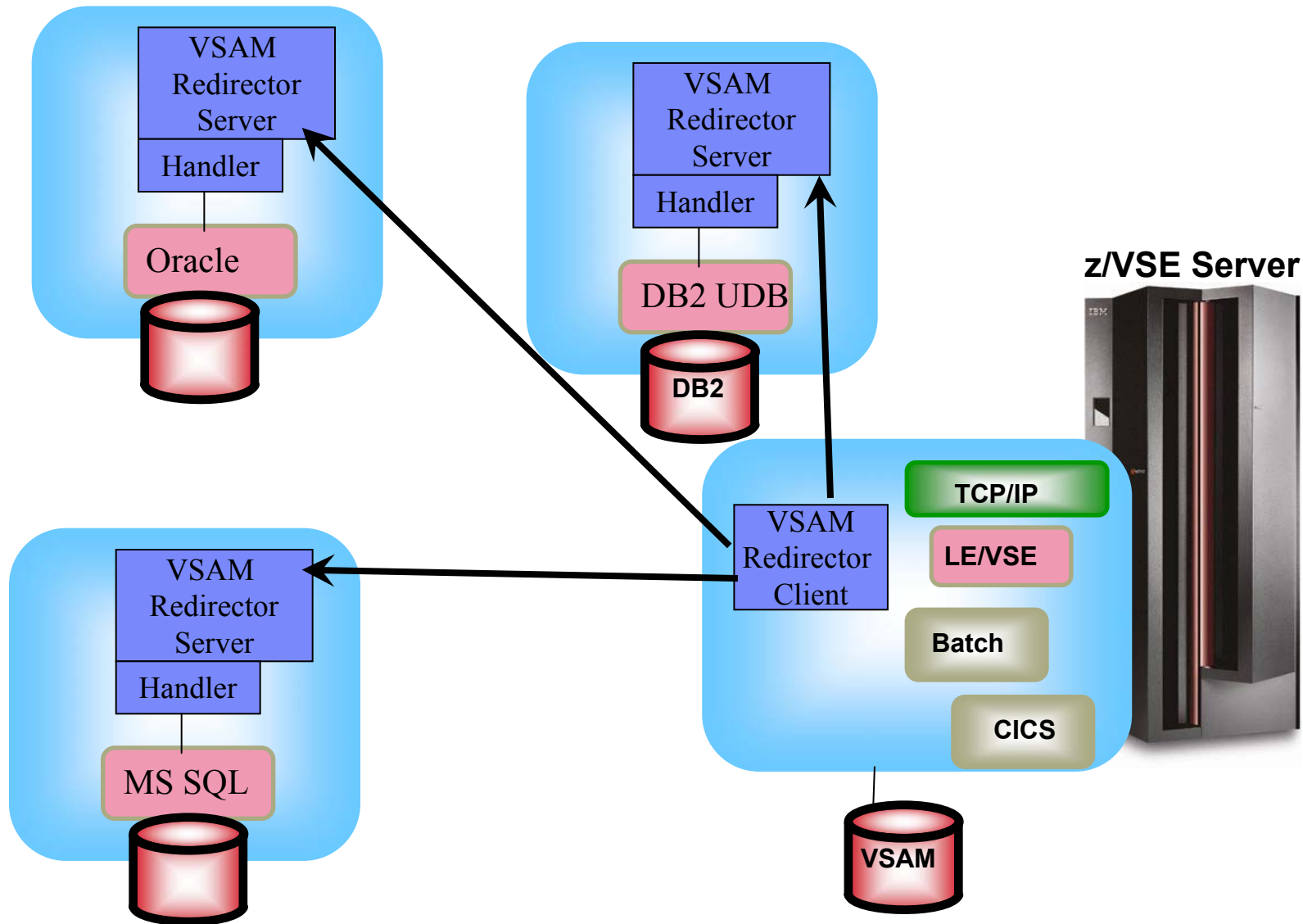

(1) Remote processing

a) Remote only processing – NO VSAM access anymore

- Requests for redirected VSAM files will be handled by VSAM Redirector client and send to the remote system.
- OWNER = REDIRECTOR
- Dataflow for a read/write request:
 - Generic exit is involved
 - VSAM Redirector Client is called
 - Redirector client sends request to Redirector Server
 - Handler processes data
 - Return Code if any is translated to VSAM error
- All reads and writes are done from/to remote

Java Platform (Linux for System z)

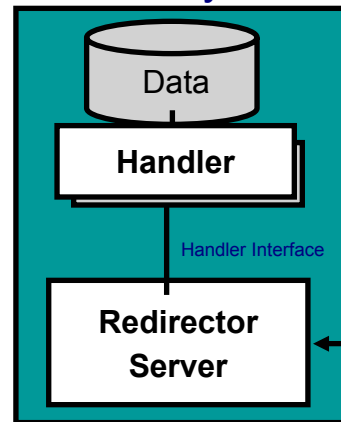

z/VSE

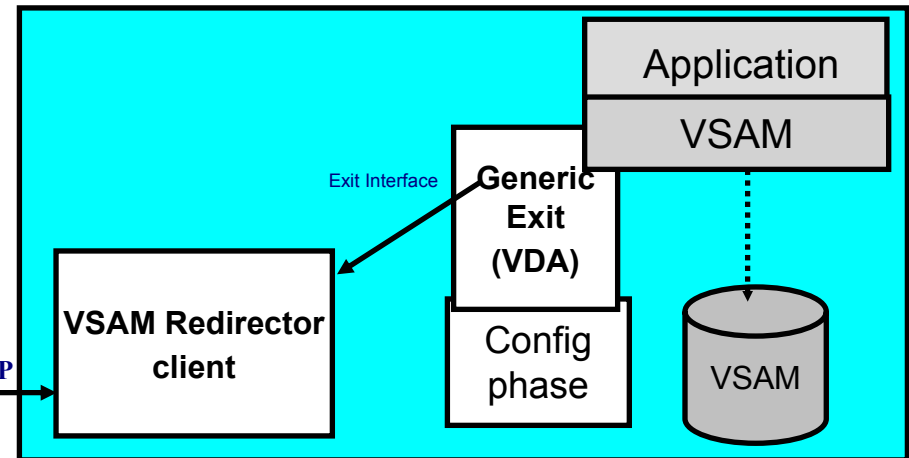

No changes required in applications (CICS, batch).

(1) Remote processing

a) Synchronization of VSAM with a database

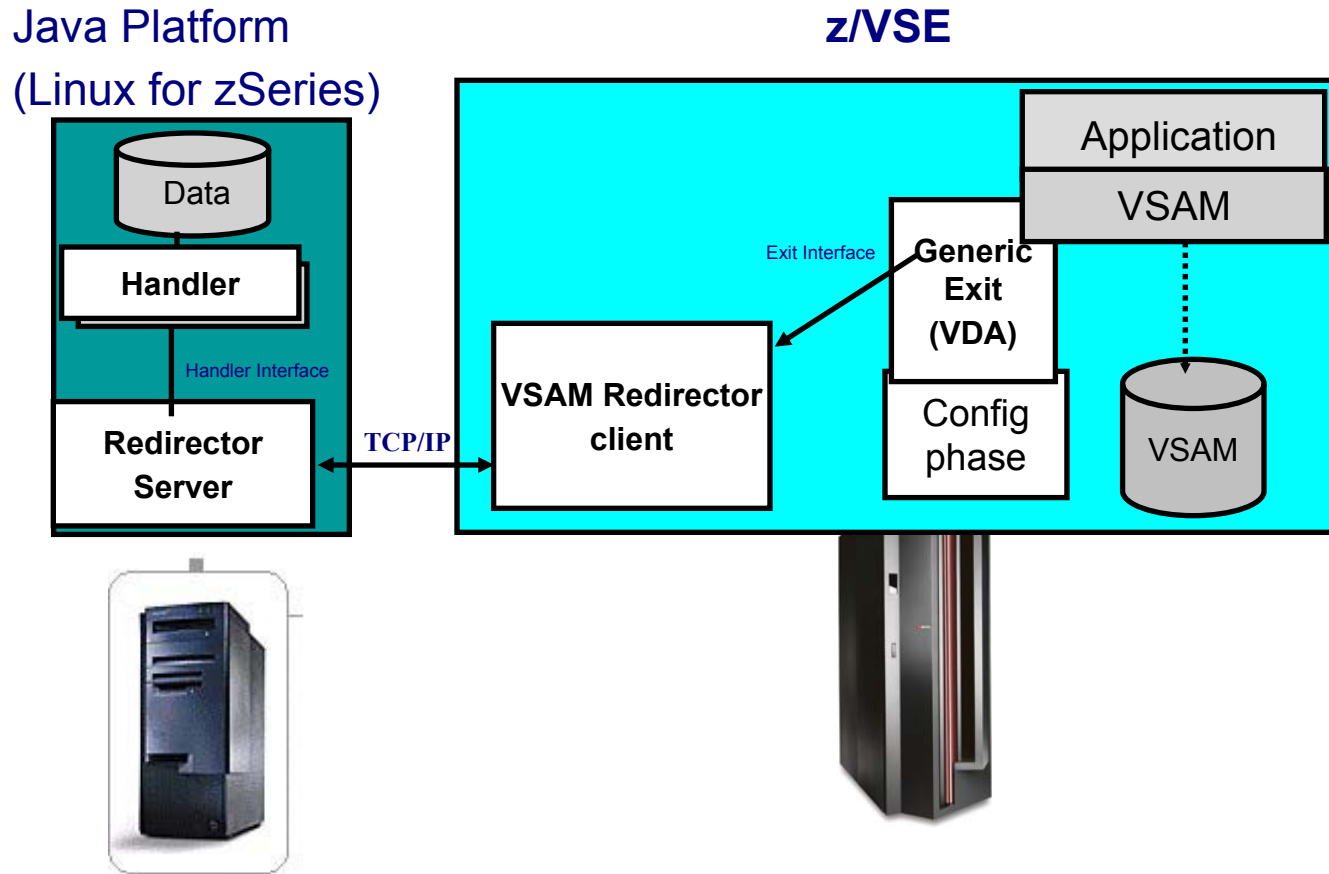

No changes required in applications (CICS, batch).

(1) Remote processing

a) Synchronization of VSAM with a database

- Requests for redirected VSAM files will be handled by VSAM Redirector client and send to the remote system.
- OWNER = VSAM
- Dataflow for a read/write request:
 - READs will be performed from VSAM only
 - Generic exit calls VSAM Redirector Client
 - Redirector client sends request to Redirector Server
 - (a) Handler processes the request in the database
 - Return Code is send back to Redirecor client
 - In case of an error it will be translated to a VSAM error
 - (b) If return code is favorable the request is processed in VSAM
 - (c-1) If the VSAM request is processed correct – the database will get a COMMIT request
 - through the Redirector Client-Server-Handler
 - (c-2) If the VSAM request ends in error – the database will get a ROLLBACK request
- This is the two phase commit mechanism to keep VSA;m and DB2 in sync

Data synchronization – Normalization

VSE/VSAM Redirector can store VSAM data normalized

- ▶ No changes to the existing VSE applications
- ▶ **The new Redirector Handler in z/VSE 4.1 can store 'VSAM' data in multiple DB Tables .**
- ▶ **Redir Loader utility provided for initial data transfer**

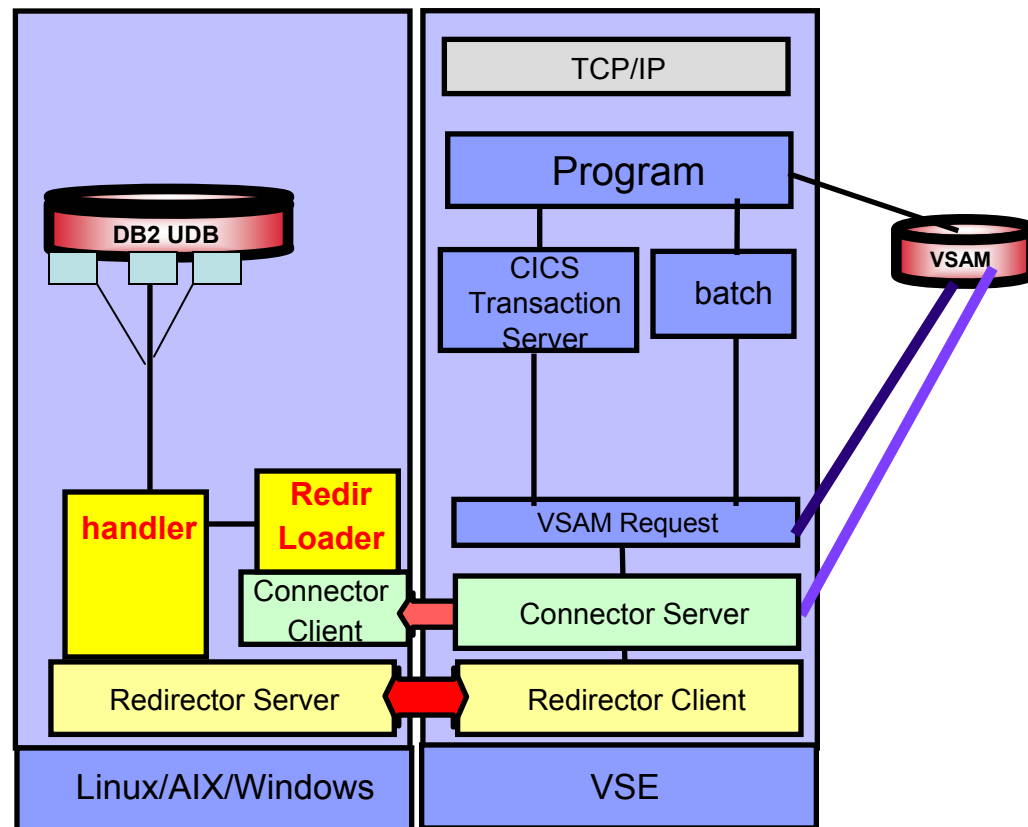

- ▶ Applications on VSE should be able to access DB2 data on Linux
- ▶ Population of DB2 UDB on Linux with VSAM using VSAM Redirector. (VSAM Redirector is part of VSE)

VSAM Redirector – Normalization - Handler

- Two different Handler with the New VSAM Redirector
 - Old: DB2Handler
 - Is still packaged with z/VSE
 - supports data access consolidation (OWNER=REDIRECTOR) as well as data synchronization (OWNER=VSAM)
 - supports DB2, Oracle, MS-SQL, ...
 - was enhanced with new data formats (packed, zoned, date, ...)
 - New: DBHandler
 - enables data Normalization
 - supports data synchronization only (OWNER=VSAM)
 - supports Record-Types
 - supports lists with fixed and variable length
 - supports new data formats (Packed, Zoned, Datum, ...)
 - supports DB2, Oracle, MS-SQL, ...

VSAM Redirector – Normalization - Handler

New Redirector handler in z/VSE 4.1

- Handler to Normalize VSAM data
 - store one VSAM record in multiple tables
 - based on VSAM indicator fields
 - administrator decision
 - for synchronization only (owner = VSAM) - READS are done from VSAM
 - relation between tables to be unique
 - definitions via GUI (mapping configuration)
 - SQL loader provided for database load
 - RedirLoader - fast initial LOAD of a database from VSAM
 - MQLoader - MQ trigger application
 - DeltaLoader – Processing of the Delta file – insert into the database

VSAM Redirector - Normalization – data types

- New extendable Concept: **Converters**
 - One Java-class per data type
 - Open interface
 - New data types can be extended easily
- Data types:
 - STRING
 - BINARY
 - BIT
 - Numbers (INTEGER, PACKED, ZONED, FLOAT, FIXEDTEXT, FLOATTEXT), supports Implied decimal positions
 - DATETIME, TOD
 - HEXCHAR
- Various Options
 - Settings (i.e. date format, number of decimals, ...)
 - Error handling: ONERROR= TERMINATE, TO-NULL, TO_ZERO
 - Text handling: TRIM, PAD, BLANK-TO-NULL, CODEPAGE

VSAM Redirector - Normalization – Record-Types

COBOL Copybook:

```

01 RECORD-3
  03 RECORD-TYPE          PIC X(1)
  03 RECORD-FORMAT-C
    05 CUSTOMER-NO       PIC X(7)
    05 CUSTOMER-NAME     PIC X(25)
    05 CUSTOMER-ADDRESS  PIC X(45)
  03 RECORD-FORMAT-P REDEFINES RECORD-FORMAT-C
    05 PRODUCT-NO        PIC X(7)
    05 PRODUCT-CATEGORY  PIC X(15)
    05 PRODUCT-NAME      PIC X(15).
  
```

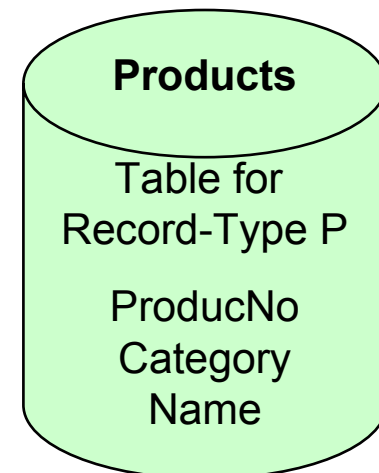
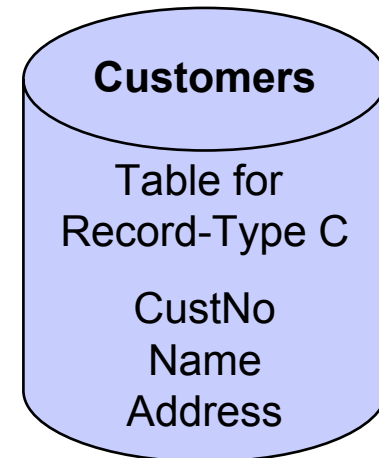

Depending on the value of Record-Type field, the data will be store in different database tables

- Type = C → Customers-Table
- Type = P → Products-Table

The association takes place at runtime for each individual record.

VSAM Redirector - Normalization – Lists

COBOL Copybook:

```

01 RECORD-2.
   03 KEYFIELD          PIC X(8) .
   03 COUNTER           PIC 9(5) COMP-3.
   03 VARIABLE-LIST OCCURS 1 TO 5
                           DEPENDING ON COUNTER.
       05 LISTFIELD-1   PIC 9(9) .
       05 LISTFIELD-2   PIC X(5) .
   03 DATAVALUE        PIC X(10) .
  
```

Depending on the value of the field Counter, there will be inserted 1 to 5 rows into the List-Table.

The relation to the Master-Table is defined through the foreign key Keyfield in the List-Table

Normalization takes place at runtime for each individual record.

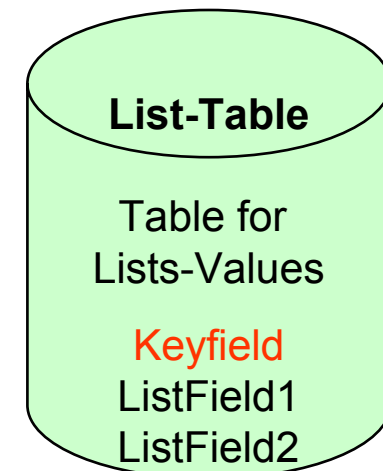
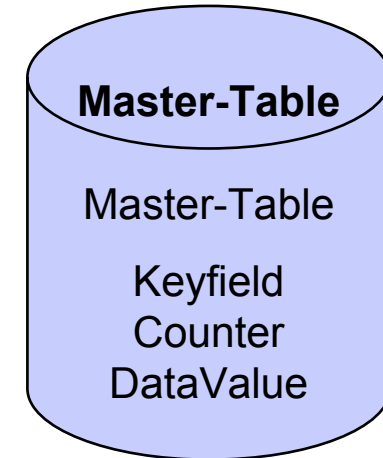

VSAM Programs with DB2 UDB on Linux on System z

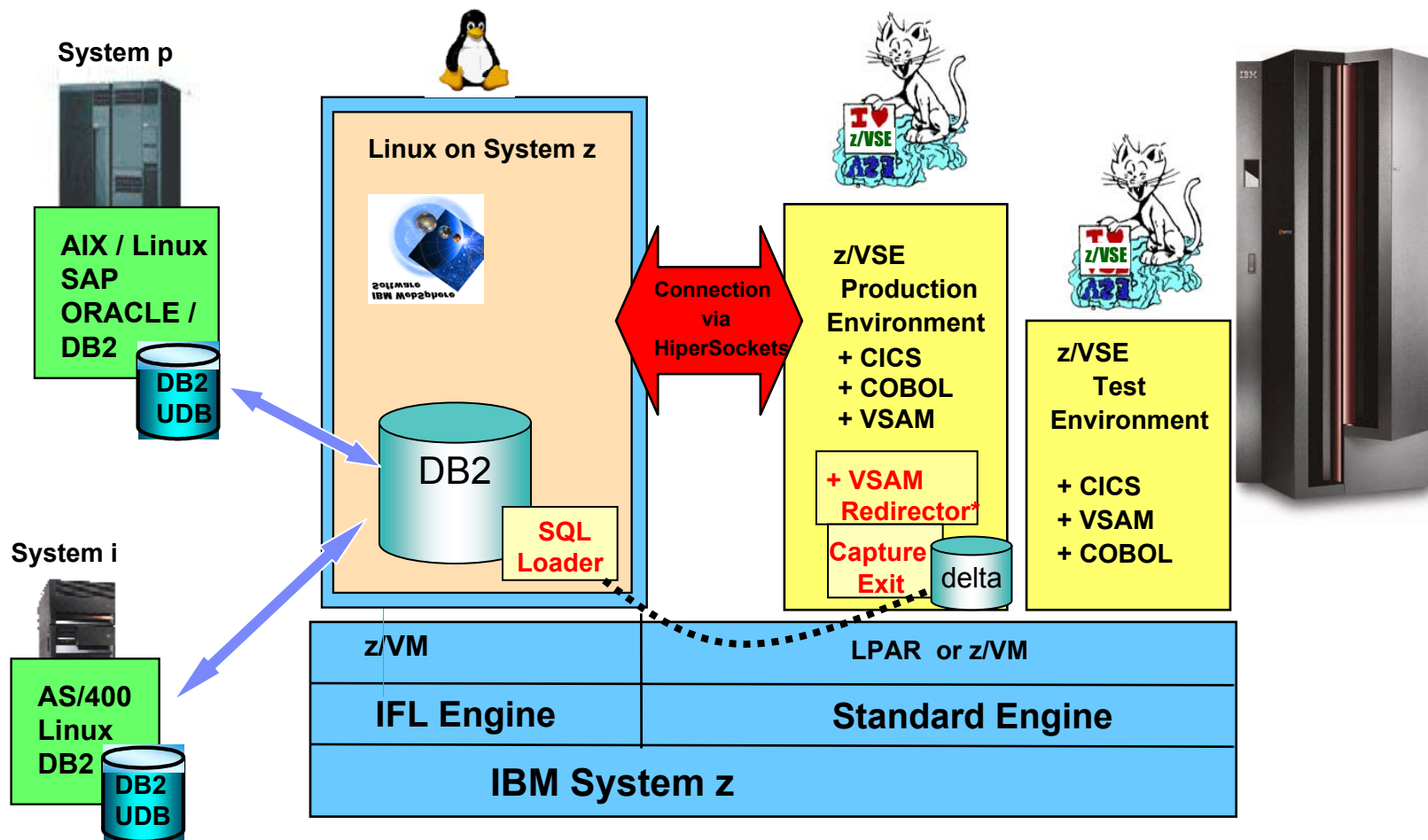

(*) VSAM Redirector – Common data store solution – with DB2 on Linux on zSeries Solutions without changes to VSAM programs

VSAM Data collection / transformation / journaling on VSE

Capture Exit

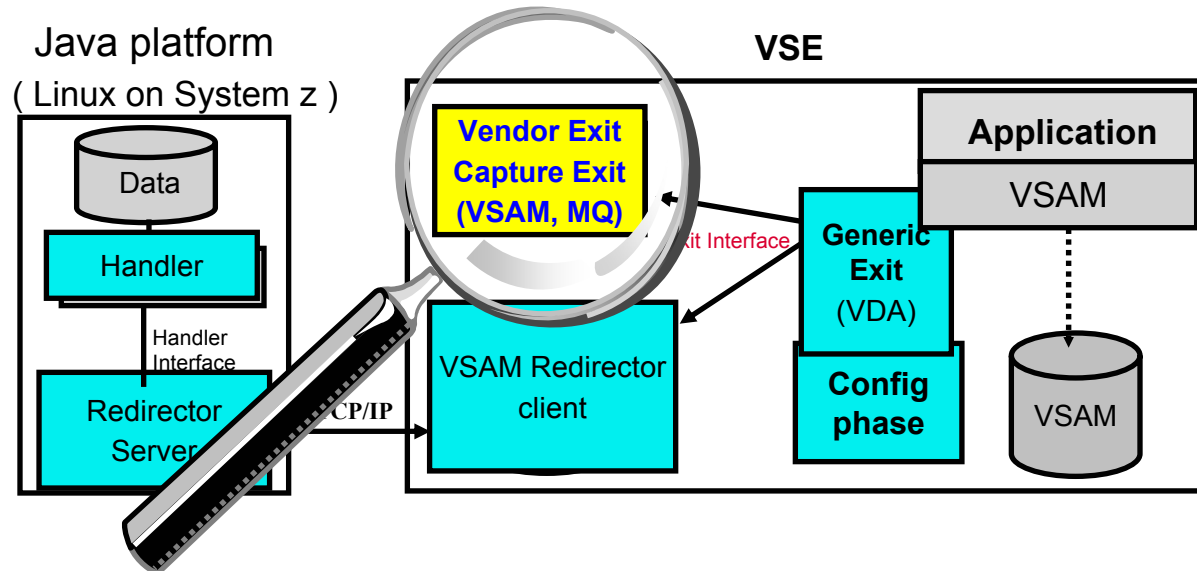

CAPTURE – wit Decision Exit as filter

► Vendor Exit

- user (vendor) written phase for data collection/transformation
- has to comply with the documented **Exit Interface**

► Capture Exit

- an exit delivered by IBM for **capturing changed VSAM** data
- an exit delivered by IBM for **generating MQ** messages

Note: No chaining of Vendor Exit with VSAM Redirector client supported

z/VSE 4.1 VSAM Redirector – Capture Exit

- Shipped in phase **IESVSCAP**
- Captures all changes to a VSAM file
 - UPDATE
 - INSERT
 - DELETE

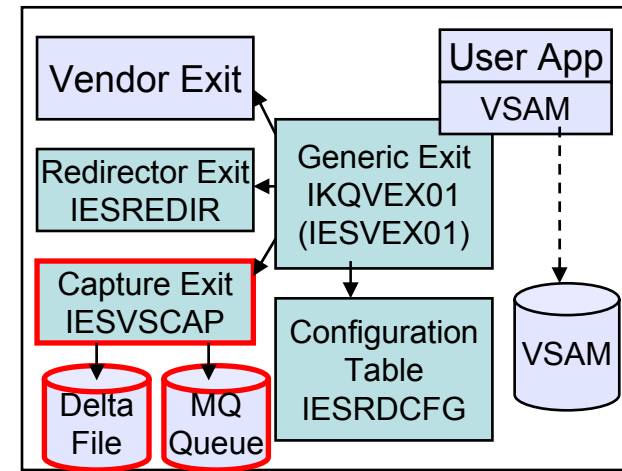

- Creates **delta records** with header + original data
 - Stored in second VSAM file (delta file)
 - Or creates MQ Series message
- Delta record header contains information about when and by whom the record was changed, and which request
- Allows customers to download the delta file and apply it to a database

Redirector Capture. Architectural View

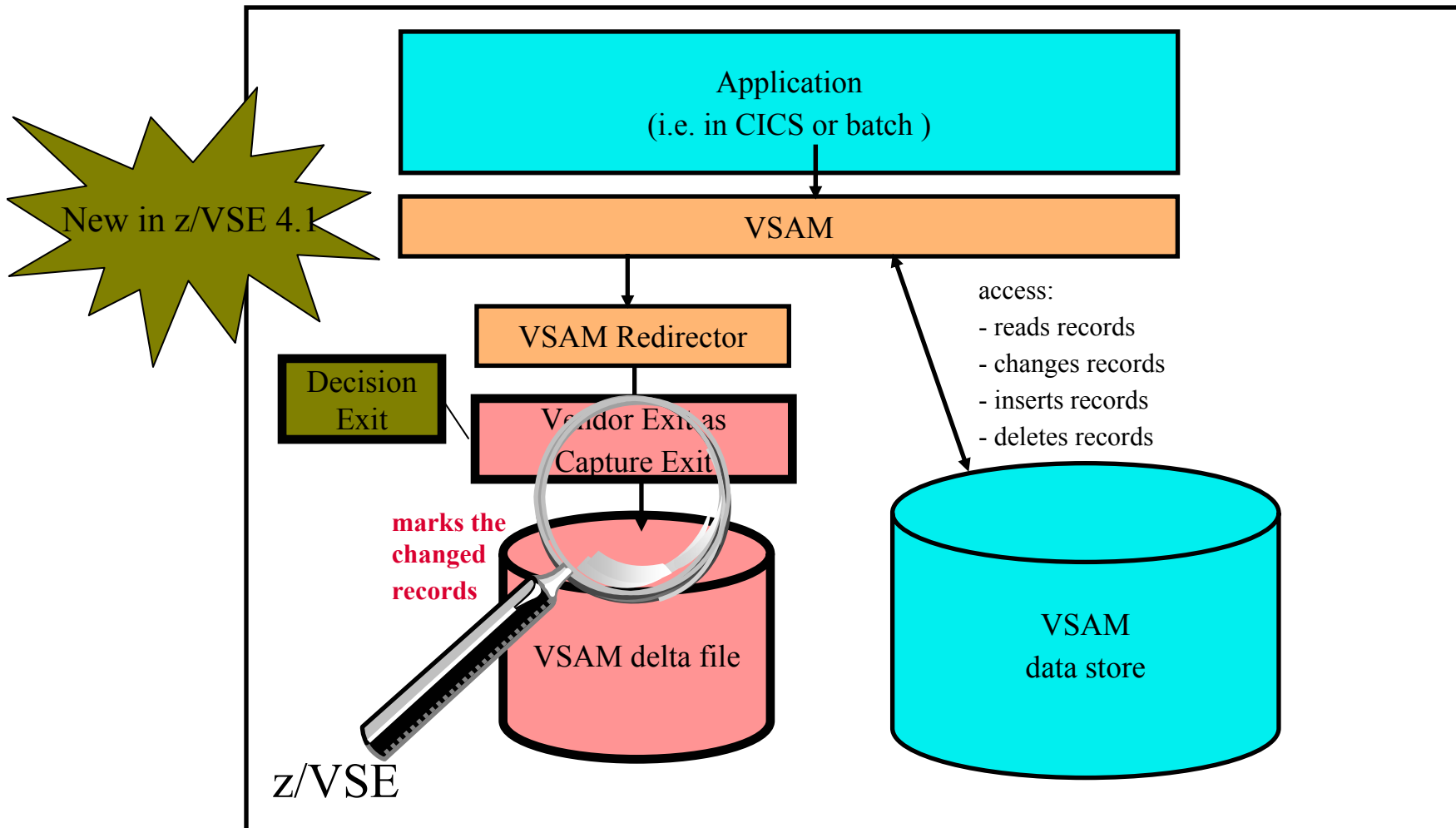

VSAM Redirector Capture

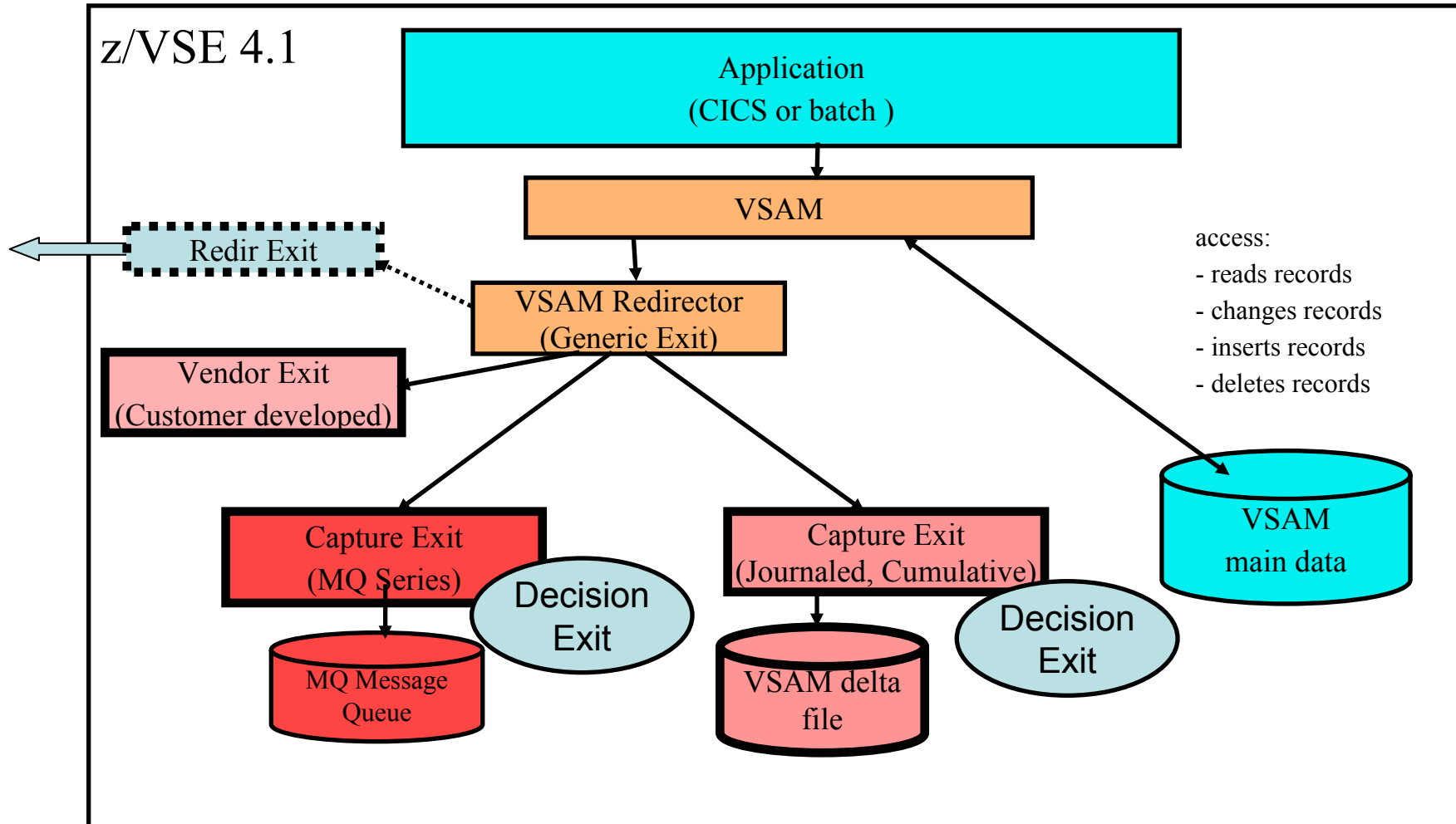

Journaling

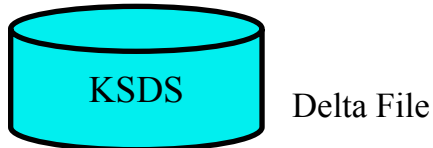

Record 1	inserted
Record 2	inserted
Record 3	inserted
Record 2	updated
Record 1	deleted
Record 3	updated
Record 4	inserted
Record 1	inserted
Record 2	updated
Record 4	updated
Record 4	deleted

or

cumulative

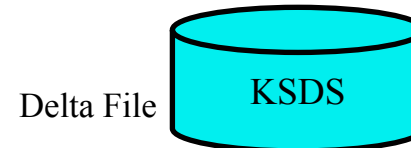

key

Record 1	inserted
Record 2	updated
Record 3	updated
Record 4	deleted

👉 The last version only of a changed VSAM record is stored into the delta file

Delta Record

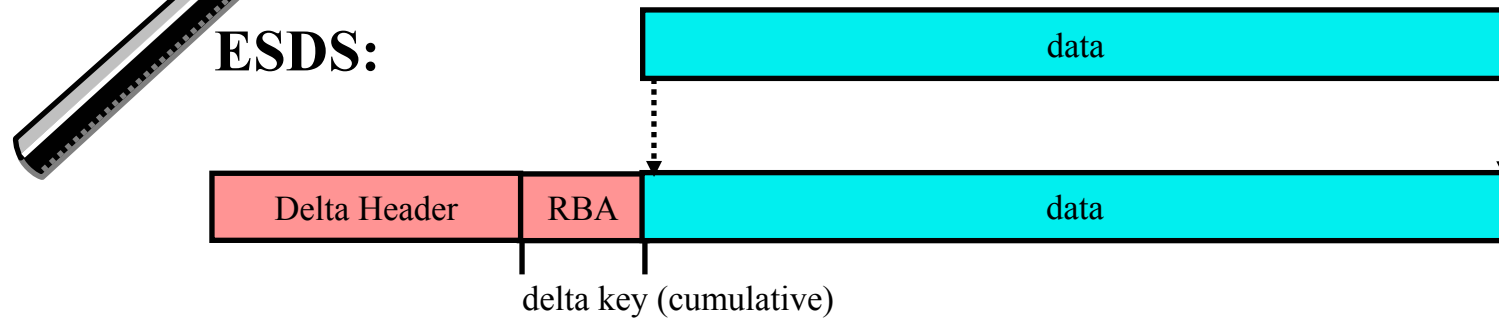
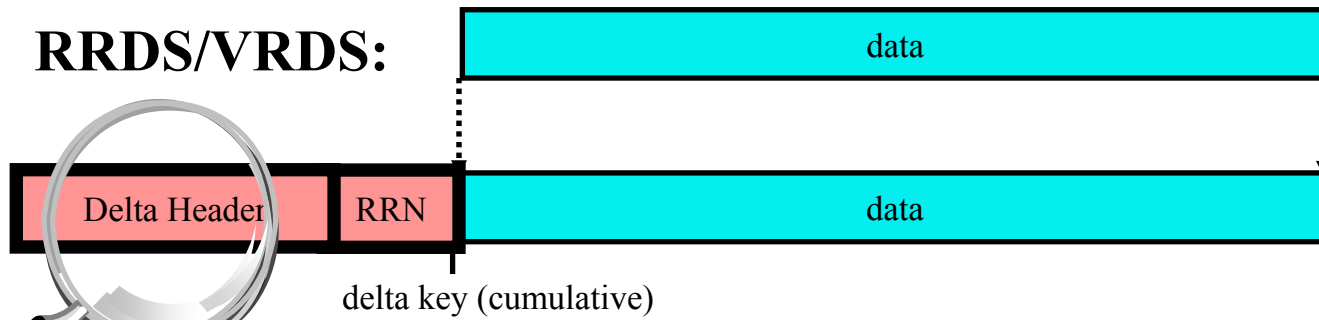
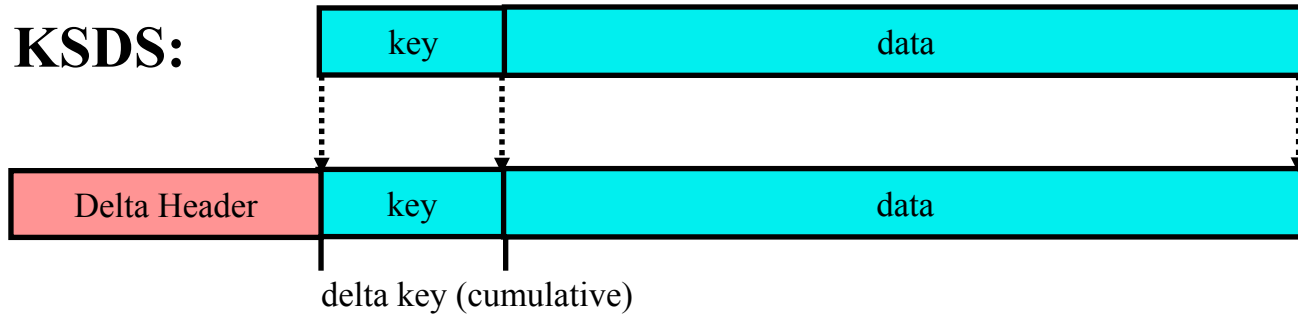

Delta Header



Offset	Parameters	Length	Description
0	TODCLOCK	8	Time of change
8	JobName	8	Job name
16	PHASEName	8	Phase name
24	Origin	8	String from Config or file Label
32	PartID	2	Partition ID (i.e. F2)
34	OpCode	1	I=Insert, D=Delete, U=Update
35	Flags	1	X'01'=RRN/RBA follows
36	RRN/RBA	4	RRN/RBA (RRDS/VRDS/ESDS)

Contains information about:

- **when** change took place (TODCLOCK)
- **who** did the change (Job/Phase/Partition)
- **request type** of change (Insert/Delete/Update)
- **which record** was affected (key/RRN/RBA)

VSAM Capture Exit - Solution options

- **Delta records** can be downloaded for processing
 - Using FTP
 - Using VSE Connector Client
 - After processing, delta records are deleted
- **Delta records** can be sent to a remote system via MQ Series
 - Asynchronous transportation or messages
 - Trigger program can process incoming messages
- Multiple VSAM files can be 'captured' into the same Delta File or MQ Series queue
 - Distinction possible via 'origin' value in header

Solution for FTP Replacement:

Bidirectional updates with VSE connectors

- ▶ With VSAM Capture – the performance of the VSE production system protected
- ▶ The changes are processed asynchronously and not influencing the production system

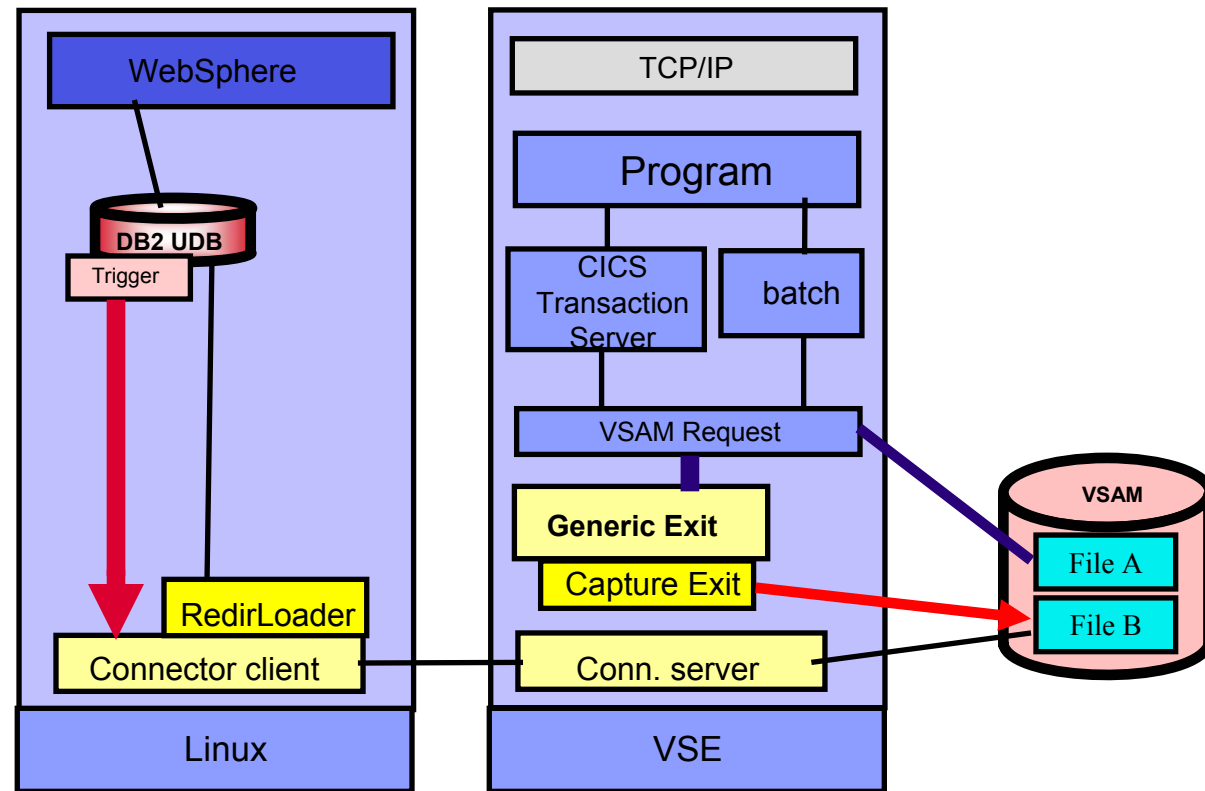

- ▶ Collect the changed records in a separate VSAM file
 - ▶ Possibility of cleansing
- ▶ Process them – with the VSE Connectors provided by IBM

Solution with MQ Messaging

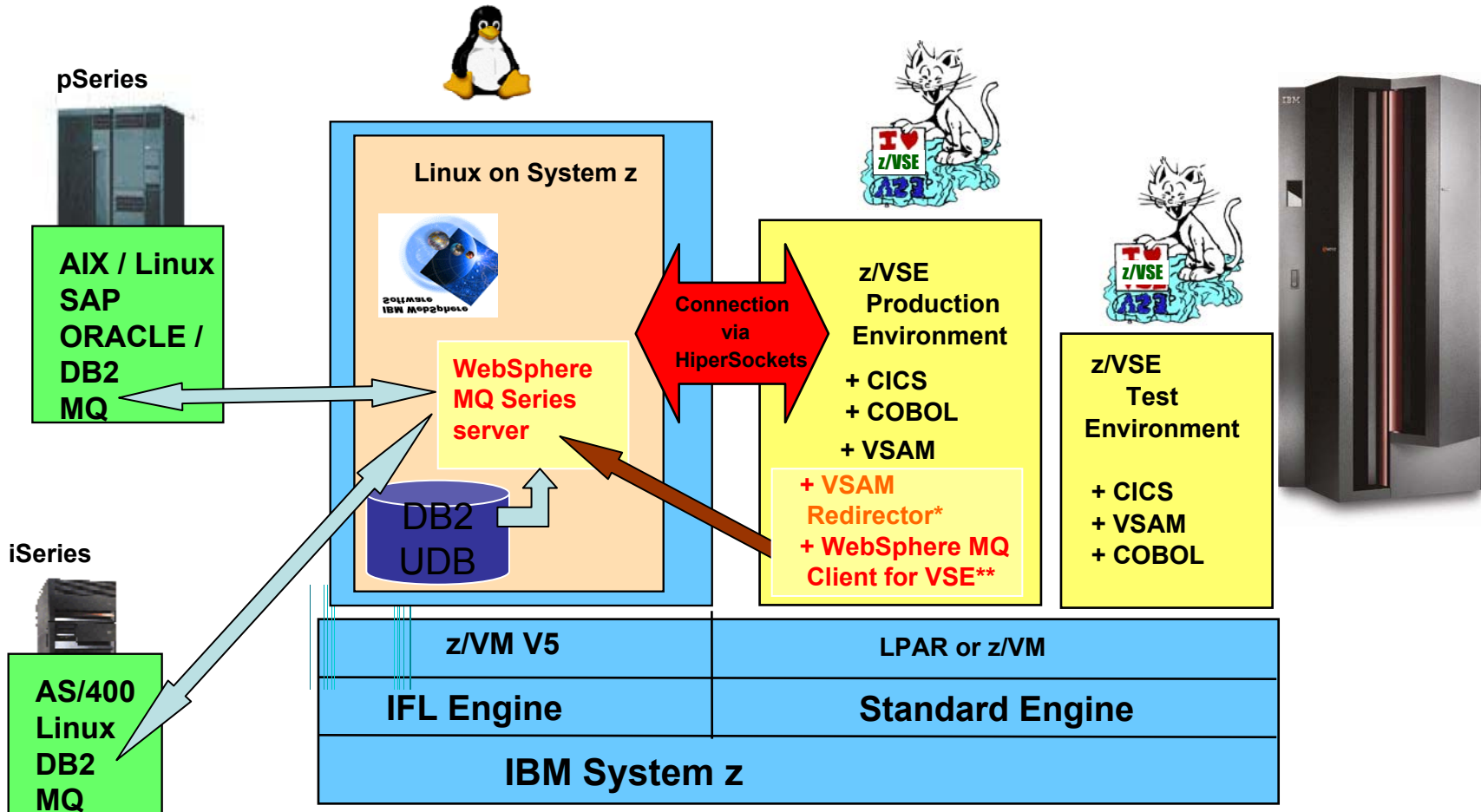

(*) VSAM Redirector + Redirector MQ Exit allows MQ Solutions without changes to VSAM programs
 (**) WebSphere MQ Client for VSE is free of charge

MQ Exit

Integration of VSE Application with MQ Series

- ▶ enablement for MQ Series w/o changing existing applications.
- ▶ Bidirectional processing
- ▶ Guaranteed processing using asynchronous data transfer method MQ

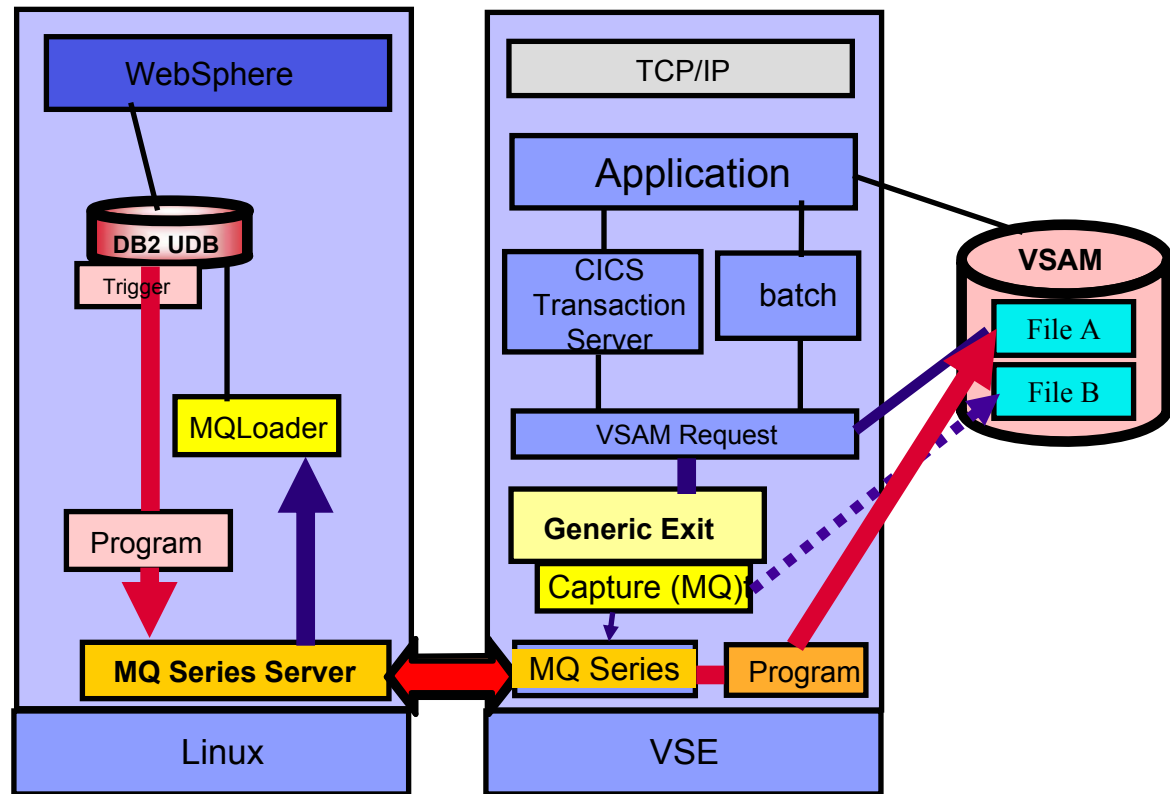

▶ tools provided by IBM

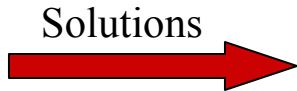

[Country/region \[select\]](#) | [Terms of use](#)

- z/VSE
- About VSE
- How to buy
- News & announcements
- Events
- Solutions**
- Products & components
- Documentation
- Service & support
- Downloads
- Education
- Partners
- FAQ
- Contact VSE

z/VSE

z/VSE is designed to help provide robust, cost-effective solutions for customers with a wide range of capacity needs, in most industries, worldwide. z/VSE is built on a heritage of ongoing refinement and innovation that spans four decades. It brings the value of innovative IBM System z and IBM System Storage technology to VSE clients.

Learn more

- [About VSE](#)
- [News](#)
- [History of VSE](#)

We're here to help

Easy ways to get the answers you need.

✉ [E-mail us](#)

Mark your calendar

WAVV-World Alliance

WAVV Conference
May 18-22, 2007
Green Bay, Wisconsin

→ [Register](#)

Announcing

Data encryption. Protect your critical data. Don't be the next headline.

→ [Learn more](#)

IBM System z9™ Business Class

A mainframe that's powerful enough to run my business and

Announcing z/VSE V4.1

Built on a heritage of ongoing refinement and innovation that spans four decades

IBM Education Announcement - z/VSE 4.1 Live Virtual Classes

z/VSE [Version 4.1](#) was recently announced on January 9, 2007. Please join us on this series of **three 1-hour technical education sessions** (delivered as Live Virtual Classes) to hear more information about z/VSE 4.1 as well as the exciting new [Midrange Workload Licensing Charges](#) (MWLC) for z/VSE 4.1. We hope you will share information about these sessions with your colleagues.

There is no tuition to participate in these sessions, however you must enroll at least 1 day ahead of the session date to enable your participation. The Live Virtual Classes (LVC) will be delivered using the Interwise tool that employs Voice over IP (VoIP) technology to provide both the audio as well as the visuals for the class to your Windows workstation. Each participant must enroll individually, ie. no sharing of LVC logins is supported. However, several participants may view and listen on one workstation.

📄 [Minimum Workstation Requirements for LVC session](#) (PDF, 9KB)

Each call will start at 8:00 a.m. Pacific US/ 11:00 a.m. Eastern US/ 4:00 p.m. GMT/ 5:00 p.m. CET. The duration for each live virtual class is 1 hour.

z/VSE and MWLC Announcement Overview - February 1 (Thursday): Jerry Johnston, z/VSE Advanced Technical Support, will present a 1-hour overview of the January 9 announcement including z/VSE 4.1 and updates to the z/VSE pricing. Time for Q&A is included to provide further information.

🔗 [Playback of z/VSE and MWLC Announcement Overview class](#)

Related links

- [Linux on IBM System z](#)
- [z/OS](#)
- [z/VM](#)
- [IBM Storage](#)
- [IBM Printing Systems](#)

<http://www.ibm.com/servers/eserver/zseries/zvse/>

34

© 2008 IBM Corporation

Additional Information

- z/VSE Home Page
<http://www.ibm.com/vse>
- z/VSE solutions
<http://www-1.ibm.com/servers/eserver/zseries/zvse/solutions>
- e-business Connectors User's Guide SC33-6719
<http://www-1.ibm.com/servers/eserver/zseries/zvse/documentation/#conn>



- e-business Solutions for VSE/ESA SG24-5662
- e-business Connectivity for VSE/ESA SG24-5950
- CICS Transaction Server for VSE/ESA
CICS Web Support *SG24-5997-00*
- WebSphere for Linux on zSeries Connectivity Handbook SG24-7042

We appreciate your comments at : zvse@de.ibm.com