

Session B54

The Basics of Using z/VM

Christine Casey

Brian Hugenbruch

z/VM Development - Endicott, NY

IBM System z Expo

September 17-21, 2007

San Antonio, TX



Trademarks

The following are trademarks of the International Business Machines Corporation in the United States and/or other countries.

CICS*	Language Environment*	S/370
DB2*	MQSeries*	S/390*
DB2 Connect	Multiprise*	S/390 Parallel Enterprise Server
DB2 Universal Database	MVS	Virtual Image Facility
DFSMS/MVS*	NetRexx	VisualAge*
DFSMS/VM*	OpenEdition*	VisualGen*
e-business logo*	OpenExtensions	VM/ESA*
Enterprise Storage Server	OS/390*	VTAM*
ESCON	Parallel Sysplex*	VSE/ESA
FICON	PRISM	WebSphere
GDDM	QMF	z/Architecture
HiperSockets	RACF*	z/OS
IBM*	RAMAC*	zSeries
IBM logo	RISC	z/VM*
	S/370	

* Registered trademarks of the IBM Corporation

The following are trademarks or registered trademarks of other companies.

Lotus, Notes, and Domino are trademarks or registered trademarks of Lotus Development Corporation.

Tivoli is a trademark of Tivoli Systems Inc.

Java and all Java-related trademarks and logos are trademarks of Sun Microsystems, Inc., in the United States and other countries.

UNIX is a registered trademark of The Open Group in the United States and other countries.

Microsoft, Windows and Windows NT are registered trademarks of Microsoft Corporation.

Notes:

Performance is in Internal Throughput Rate (ITR) ratio based on measurements and projections using standard IBM benchmarks in a controlled environment. The actual throughput that any user will experience will vary depending upon considerations such as the amount of multiprogramming in the user's job stream, the I/O configuration, the storage configuration, and the workload processed. Therefore, no assurance can be given that an individual user will achieve throughput improvements equivalent to the performance ratios stated here.

IBM hardware products are manufactured from new parts, or new and serviceable used parts. Regardless, our warranty terms apply.

All customer examples cited or described in this presentation are presented as illustrations of the manner in which some customers have used IBM products and the results they may have achieved. Actual environmental costs and performance characteristics will vary depending on individual customer configurations and conditions.

This publication was produced in the United States. IBM may not offer the products, services or features discussed in this document in other countries, and the information may be subject to change without notice. Consult your local IBM business contact for information on the product or services available in your area.

IBM considers a product "Year 2000 ready" if the product, when used in accordance with its associated documentation, is capable of correctly processing, providing and/or receiving date data within and between the 20th and 21st centuries, provided that all products (for example, hardware, software and firmware) used with the product properly exchange accurate date data with it. Any statements concerning the Year 2000 readiness of any IBM products contained in this presentation are Year 2000 Readiness Disclosures, subject to the Year 2000 Information and Readiness Disclosure Act of 1996.

All statements regarding IBM's future direction and intent are subject to change or withdrawal without notice, and represent goals and objectives only.

Information about non-IBM products is obtained from the manufacturers of those products or their published announcements. IBM has not tested those products and cannot confirm the performance, compatibility, or any other claims related to non-IBM products. Questions on the capabilities of non-IBM products should be addressed to the suppliers of those products.

Disclaimer

The information contained in this document is not intended to be an assertion of future action by IBM. The use of this information or the implementation of any of these techniques is a customer responsibility and depends on the customer's ability to evaluate and integrate them into the operational environment. While each item may have been reviewed by IBM for accuracy in a specific situation, there is no guarantee that the same or similar results will be obtained elsewhere. Customers attempting to adopt these techniques to their own environment do so at their own risk.

In this presentation, any references made to an IBM licensed program are not intended to state or imply that only IBM's licensed program may be used; any functionally equivalent program may be used instead.

Any performance data contained in this presentation was determined in a controlled environment and, therefore, the results which may be obtained in other operating environments may vary significantly. Users of this presentation should verify the applicable data for their specific environment.

It is possible that this material may contain reference to, or information about, IBM products (machines and programs), programming, or services that are not announced in your country. Such references or information must not be construed to mean that IBM intends to announce such IBM products, programming or services in your country.

Any feedback that you give IBM regarding this presentation will be treated as non-confidential information. IBM reserves the right to use this information in any form.

Agenda

- Overview
- General Concepts
 - ▶ Establishing VM Sessions
 - ▶ Logging onto the Virtual Console
 - ▶ User Directory
 - ▶ Execution Modes
- Using CMS
 - ▶ Commands
 - ▶ CMS File System
 - ▶ Developing Programs - Xedit, Execs, Pipelines...
- Debugging

Overview

- VM contains Two Basic Parts
 - ▶ CP - Control Program
 - ▶ CMS (or Guests LINUX, CP, z/OS, etc.)

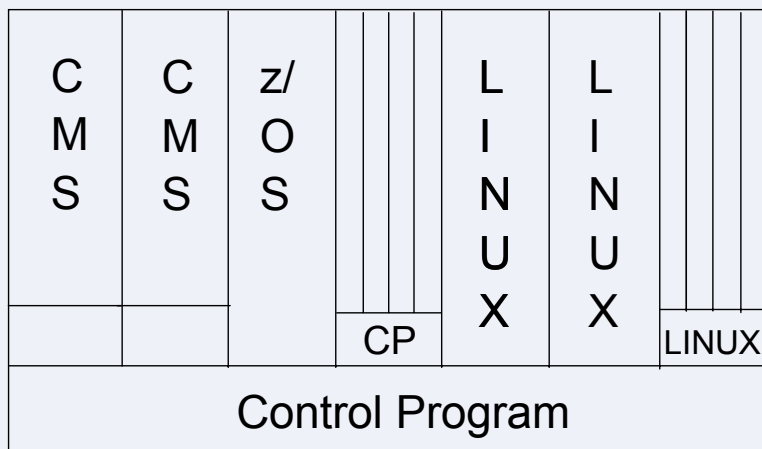

CMS General Concepts

- CMS: Conversational Monitor System
- CMS is an interactive user interface that runs under the control of CP
- Provides an application programming and execution environment
 - ▶ Commands, EXECs (scripts), pipelines, Xedit, compilers, user programs
- Many tools available
 - ▶ Productivity Aids, REXX, Vendor programs

CMS Strengths

- User-friendly
 - English-like, extensible command language
 - Simple, easy-to-use file system
- Cooperates well with CP
 - ▶ Commands to exploit CP function and devices
 - ▶ Exploits virtual machine concepts
 - ▶ Commands can be automatically passed to CP:
 - If not found in CMS, or directly by issuing #CP command
- High performance
 - ▶ Single-user orientation
 - ▶ Shared CMS Nucleus, DCSS (Discontiguous Saved Segment)
 - ▶ File system performance

Environments

- CMS
 - ▶ IPL CMS or Begin, run Profile Exec
 - ▶ Linemode or Fullscreen mode
 - XEDIT Environment
 - ▶ XEDIT *fn ft fm*, run Profile Xedit
 - ▶ CMS Subset mode
 - Unix-like
 - ▶ Open Extensions (Posix Shell & Utilities) *
 - ▶ Byte File System, Network File System
 - z/OS-like or VSE-like
 - ▶ OS Simulation *
 - ▶ DOS Simulation *
- * not a full duplication of function

Establishing a VM Session

- VM Logo Screen
 - ▶ One at a time - 3270 emulation (pcom)
 - ▶ LOGON ... here -> move a signon to another session
 - ▶ LOGON ... by ... -> signon using another password

- Using CP to control the Virtual Machine
 - ▶ #CP IPL CMS - restart your entire CMS session
 - profile exec runs to customize your session
 - ▶ #CP LOGOFF - logon xxx - sign off/on

VM Logo Screen

```

Session A - [24 x 80]
File Edit View Communication Actions Window Help
z/VM ONLINE

                          Use Of This System Is For
                          IBM Management Approved Purposes Only

=====  =====  =====  =====
=====  =====  =====  =====
===      ==      ==      =====  =====
===      =====  =====  =====
===      =====  =====  =====
===      ==      ==      =====  =====
=====  =====  =====  =====
=====  =====  =====  =====

      For help call the Customer Service Center:
                        888-IBM-HELP
VTAM Customers: To exit screen, enter VMEXIT

Fill in your USERID and PASSWORD and press ENTER
(Your password will not appear when you type it)
USERID  ==>
PASSWORD ==>
COMMAND ==>

                                         RUNNING  GDLVM7
-----
M  a                                         20/016
-----
Connected to remote server/host GDLVM7.endicott.ibm.com using port 23
My Printer on LPT1:
  
```

Sample User Directory

USER IBMUSER IBMUSER 16M 16M G
ACCOUNT SYSTEMS
MACH XA
IPL CMS



CONSOLE 009 3215
SPOOL 00C 2540 READER *
SPOOL 00D 2540 PUNCH A
SPOOL 00E 1403 A

LINK MAINT 0190 0190 RR * CMS system disk
LINK MAINT 019E 019E RR * Product code disk
LINK 5767002P 29E 29E RR
LINK 5767002P 505 305 RR
LINK 5767002P 191 192 RR
MDISK 191 3390 1535 001 510RES MR READ WRITE MULTIPLE

Sessions

Session B - [24 x 80]
 File Edit View Communication Actions Window Help
 Ready;
 —
 RUNNING GDLVM7
 b 23/001
 Connected to remote server/host GDLVM7.endicott.ibm.com using port 23
 My Printer on LPT1:

Execution Modes



- Status appears at the bottom right of screen
 - ▶ CP Read (CP is waiting for a command)
 - ▶ VM Read (CMS is waiting for a command)
 - ▶ Running (Ready for cmds or working on some)
 - ▶ More... (More info than can fit on the screen)
 - 50 seconds then beep then 10 seconds
 - Determine setting: Query Term
 - Page without waiting: Term More 0 0
 - ▶ Holding (Waiting for you to clear the screen)
 - ▶ Not Accepted (Too many commands in buffer; wait for executing command to complete)

CMS Commands

- Handles a system of files: (create, modify, debug)
- Many language processors/compilers can run under CMS
- Commands are blank-delimited
- Input accepted in ANY case
 - ▶ CMS will automatically uppercase and pass to command parser
- General syntax:

```
Command name [operand(s)...] [ (options.... [ ] ) ]
```

 - ▶ Examples:

```
copy Profile Exec A = = C
LISTFILE ( Date
Rdlist
```
- SET DOS On command simulates a VSE (DOS) environment

CMS Commands

- Command Search Order
 - ▶ When a command is entered, CMS has to locate it
 - ▶ Search for an EXEC with the specified command name
 - EXECs in storage
 - Command name with Filetype EXEC on accessed disk or directory (A-Z)
 - ▶ Search for translation or synonym
 - ▶ Search for a module with the specified command name
 - Nucleus extension, transient area, nucleus resident, on accessed disk/directory
 - ▶ If Command not found in CMS, it will be passed to CP for execution unless SET IMPCP is OFF (Implied CP)

CMS Commands

- Immediate Commands
 - ▶ Can be entered while another command is running
 - ▶ Interrupts the running command and executes immediately
 - ▶ 10 system immediate commands:
HB, HI, HO, HT, HX, RT, RO, SO, TE, TS
 - ▶ User's can define their own immediate commands
 - IMMCMD Macro from an Assembler program
 - IMMCMD Command from an EXEC
 - IMMCMD option on NUCXLOAD command

CMS File System

- CMS files are unique and generally cannot be read or written by other operating systems
- Files are named using a file identifier (file ID) consisting of 3 fields:
 - ▶ File name (FN)
 - ▶ File type (FT)
 - ▶ File mode (FM) or Directory name (dirname)
 - file mode letter A-Z where minidisk or directory resides, established by ACCESS command
 - file mode number 0-6 assigned when file is created or renamed (default = 1), used to identify or operate on a subset of files

CMS File System

- Files can be stored in several ways:
 - ▶ On Minidisks (fn ft fm)
 - Standard file modes: A - user's disk, S - system disk, Y/S - installed programs
 - ▶ In an SFS (Shared File System) filespace:
(GPLSRV2:CASEY.SSL.C.EXAMPLES)
 - ▶ On the BFS (Byte File System) (/home/userid/...)
 - hierarchical file structure
 - ▶ In NFS (Network File System)

CMS Minidisks

- CMS User, Link 191 minidisk, Access as A

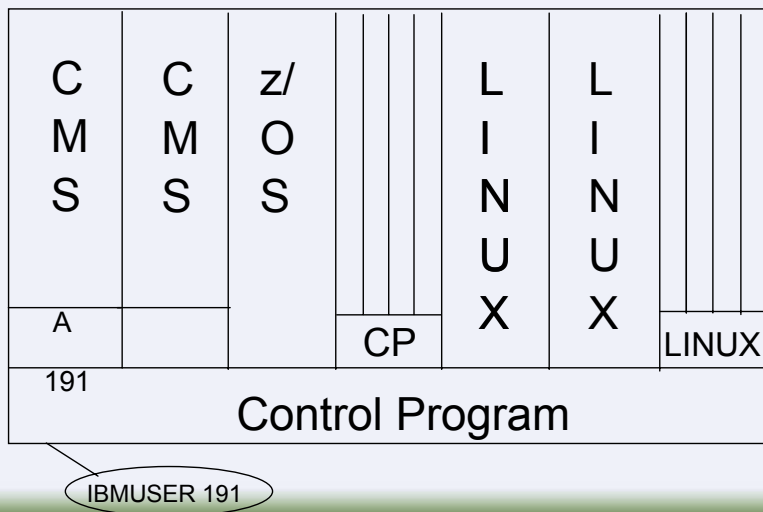

Sample User Directory

USER IBMUSER IBMUSER 16M 16M G
 ACCOUNT SYSTEMS
 MACH XA
 IPL CMS

CONSOLE 009 3215
 SPOOL 00C 2540 READER *
 SPOOL 00D 2540 PUNCH A
 SPOOL 00E 1403 A

LINK MAINT 0190 0190 RR * CMS system disk
 LINK MAINT 019E 019E RR * Product code disk
 LINK 5767002P 29E 29E RR
 LINK 5767002P 505 305 RR
 LINK 5767002P 191 192 RR

MDISK 191 3390 1535 001 510RES MR READ WRITE MULTIPLE



File system - Minidisks

- A location on real DASD which has been allocated for storage of a user's files
- 3 types of minidisks:
 - ▶ Permanent
 - lasts across sessions (logons); defined in directory
 - ▶ Temporary (T-disks)
 - are destroyed at logoff
 - use CP DEFINE command or attach by operator
 - ▶ Virtual disks in storage (V-disks)
 - temporary simulations of minidisks in system storage
 - not allocated on real DASD; avoids I/O overhead

File system - Disk Commands

- CP DEFINE, CP LINK, CMS ACCESS
 - ▶ Defines a virtual device or virtual disk in storage
 - **DEFINE t3380 as 291 cyl 10**
 - ▶ Link to other user's minidisks to share files
 - LINK caseyct 191 291 rr
 - ▶ Once linked, a disk can be accessed
 - ACCESS 291 c
- FORMAT
 - ▶ **Minidisks must be formatted before using the first time**
 - FORMAT 291 c

Disk Commands (cont.)...

- **RELEASE, CP DETACH**
 - ▶ Release frees an accessed disk
 - Release c
 - ▶ Detach removes the device from your VM configuration
 - Detach 291 -or- Release c (detach)
- **CP QUERY DASD**
 - ▶ Shows what you have linked; displays status
- **Q ACCESSED, Q DISK, Q SEARCH**
 - ▶ Shows various status information for accessed disks/directories
- **LISTFILE, FILELIST**
 - ▶ Lists the files on an accessed minidisk or directory

Developing Programs

- **Creating and Compiling**
 - ▶ Use XEDIT to create the program like any other file
 - ▶ Filetype indicates name of programming language you are using
 - Assemble, Fortran, C, Cobol, PLI, etc.
 - ▶ Invoke the compiler by typing compiler name followed by File name of the program
 - ▶ **LISTING and TEXT files are produced**
 - example: `ASSEMBLE ASM1` result: `ASM1 LISTING`
`ASM1 TEXT`



XEDIT

- Command: Xedit fn ft fm
- Each line is a record
- Screen Layout:

TEST FILE A1 F 80 Trunc=80 Size=45 Line=0 Col=1 Alt=0

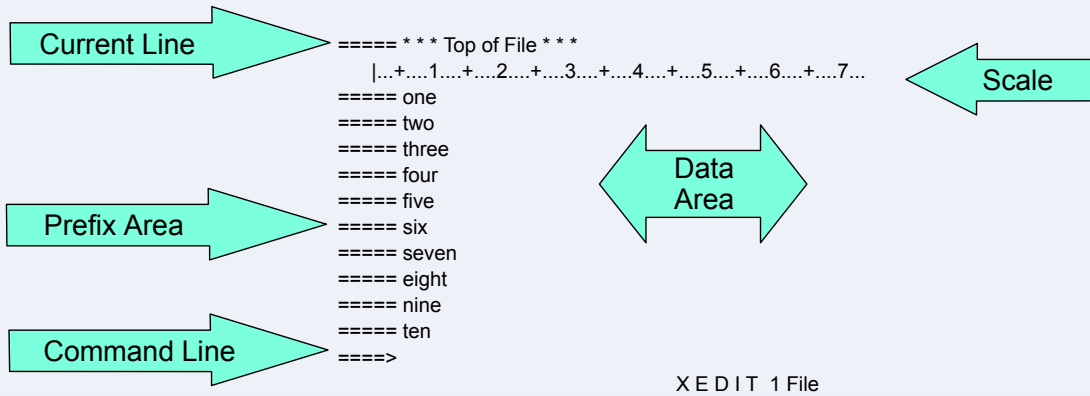

XEDIT

- Prefix Commands (subset)
 - m, mm mm - move
 - c, cc cc - copy
 - f - following
 - p - preceding
 - a - add
 - si - sequential insert
 - d, dd dd - delete
 - ", "" "" - repeat

XEDIT

- Command line commands
 - ▶ screen format
 - ▶ change /xxx/yyy/ * *
 - ▶ /zzz/ (find zzz in text)
 - ▶ all /zzz/ (find all zzz at once)

- Ending
 - ▶ QQuit - leave and doesn't save changes
 - ▶ SAVE - doesn't leave, but does save changes
 - ▶ FILE - leave and save changes

XEDIT

- Write your own command
 - ▶ Name: yourcmdn XEDIT
 - ▶ Write using REXX
 - ▶ Use: EXTRACT to get session information
 - ▶ Can use Pipelines

XEDIT

■ Default Program Function Keys

- PF1 BEFORE HELP MENU
- PF2 BEFORE SOS LINEADD
- PF3 BEFORE QUIT
- PF4 BEFORE TABKEY
- PF5 BEFORE SCHANGE 6
- PF6 ONLY ?
- PF7 BEFORE BACKWARD
- PF8 BEFORE FORWARD
- PF9 ONLY =
- PF10 BEFORE RGTLEFT
- PF11 BEFORE SPLTJOIN
- PF12 BEFORE CURSOR HOME

XEDIT

- PROFILE XEDIT runs when XEDIT is invoked
- Sample: PROFILE XEDIT

```
/* PROFILE XEDIT */  
'SET VERIFY OFF 1 72'  
'SET NUMBER ON'  
'SET PREFIX NULL'  
'SET CASE MIXED IGNORE'  
'SET CURLINE ON 4'  
'SET SCALE OFF'  
'SET AUTOSAVE 1'
```

- Note: Xedit is very tailorable !

XEDIT

■ New Screen Layout

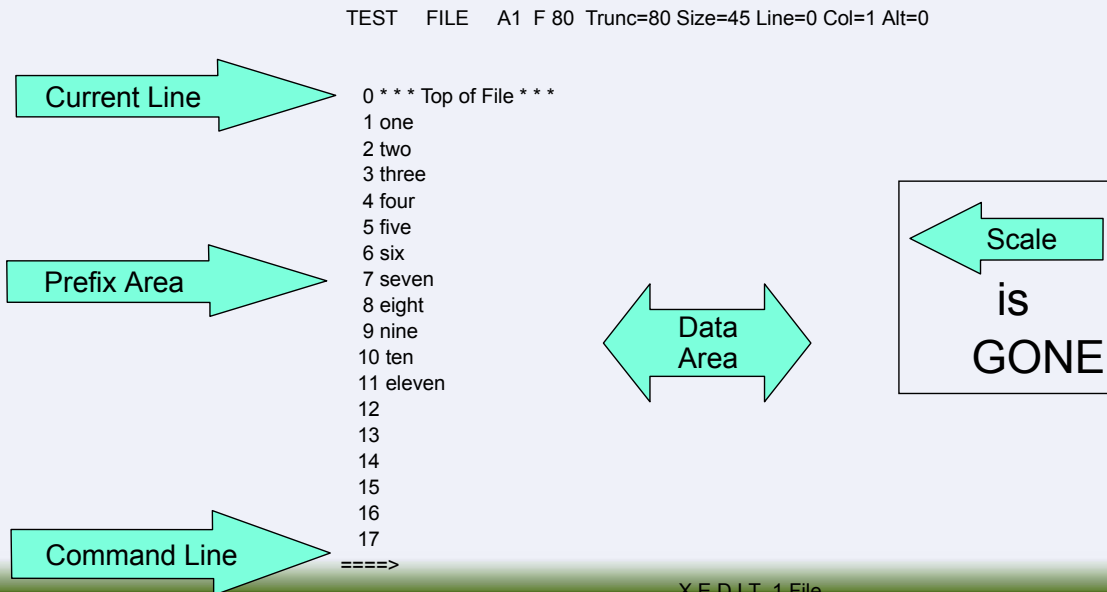

XEDIT

■ ISPF prefixes - PROFILE XEDIT

```

/* to mimic ISPF          */
'SET PREFIX SYNONYM B P   '
'SET PREFIX SYNONYM A F   '
'SET PREFIX SYNONYM R "   '
'SET PREFIX SYNONYM RR "" '

```

EXECs

- Types: EXEC, EXEC2, and REXX
- REXX
 - ▶ /* starts with a comment */
 - ▶ Contains Variables and Stemmed Arrays
 - Stores Strings and Numbers as strings
 - ▶ Has 'flow control'
 - do and do while
 - if then else
 - select
 - interpret
 - ▶ Allows Functions and Procedures
 - ▶ Issues CP/CMS commands (in quotes)

EXECs

- PROFILE EXEC runs when you sign on

```
/* Profile Exec Sample */
'SYNONYM HUGENBRU SYNONYM
A'
'CP SPOOL CONS * START'
'CP TRACE END'
'CP SET MSG ON'
'CP SET PF12 RET'
```

```
HUGENBRU SYNONYM A
0 * * * Top of File * * *
1  RECEIVE  REC    3
2 * * * End of File * * *
```

Pipelines

- CMS command
- Several Programs (stages) pass records
- Many sources for data
 - ▶ commands
 - ▶ xedit
 - ▶ disks
 - ▶ storage, etc.
- Example:

```

            'pipe ',
            '| < my data a',
            '| locate /my line/',
            '| > mynew data a'
```

Spool Devices

- Reader, Printer, Punch

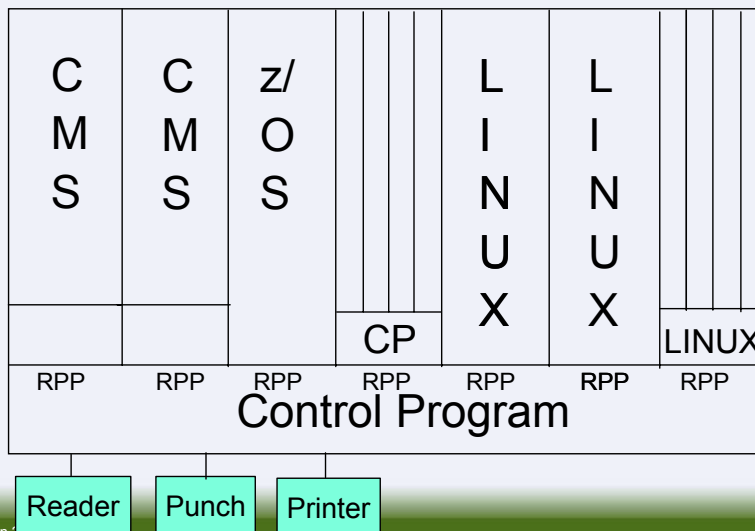

Sample User Directory

USER IBMUSER IBMUSER 16M 16M G
 ACCOUNT SYSTEMS
 MACH XA
 IPL CMS

CONSOLE 009 3215
 SPOOL 00C 2540 READER *
 SPOOL 00D 2540 PUNCH A
 SPOOL 00E 1403 A

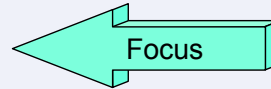

LINK MAINT 0190 0190 RR * CMS system disk
 LINK MAINT 019E 019E RR * Product code disk
 LINK 5767002P 29E 29E RR
 LINK 5767002P 505 305 RR
 LINK 5767002P 191 192 RR
 MDISK 191 3390 1535 001 510RES MR READ WRITE MULTIPLE

Debugging

- Record your console
 - spool console to * start (to start recording)
 - ... (do work)
 - spool console stop close (console punched to reader)
 - query reader all (to get the spool id)
 - rdrlist
 - peek {spool id} (for * (to look at the console)
 - receive {spool id} fn ft fm (to save console in a file)

Debugging

- Tracing
 - trace i r12345.10
 - trace instructions @ location 12345 for x'10' bytes
 - display g (display general registers)
 - d t12345.20 (display translated storage for x20)
 - b (begin execution)
 - trace end (end tracing)

- Dumps
 - VMDUMP
 - VM Dump Tool

References

- VM Library
 - ▶ <http://www.vm.ibm.com/library>

- XEDIT Tutorial
 - ▶ <http://www.vm.ibm.com/tutorial>

- HELP Facility
 - ▶ HELP command
 - ▶ HELP msg DMSxxxE
 - ▶ CP Link MAINT 19D 19D rr
 - link for HELP disk

Development Contacts

■ Brian Hugenbruch

- Phone: (607) 429-3660
- Internet: BWHUGEN@US.IBM.COM
- Postal mail
 - IBM Department G32G
 - 1701 North Street
 - Endicott, NY 13760 U.S.A.

■ Christine Casey

- Phone: (607) 429-3434
- Internet: CASEYCT@US.IBM.COM
- Postal mail
 - IBM Department G32G
 - 1701 North Street
 - Endicott, NY 13760 U.S.A.