

IBM TRAINING



IBM STG Technical Conference

IBM Systems and Technology Group Technical Conference

Munich, Germany

April 16-20, 2007

E43 z/VSE 4.1 Update and Enterprise Modernization

Wilhelm Mild
z/VSE Solution Architect

Trademarks

The following are Trademarks of the International Business Machines Corporation in the United States and / or other countries.

CICS*	IBM*	Virtual Image Facility
DB2*	IBM logo*	VM/ESA*
DB2 Connect	IMS	VSE/ESA
DB2 Universal Database	Intelligent Miner	z/VSE
e-business logo*	Multiprise*	VisualAge*
Enterprise Storage Server	MQSeries*	VTAM*
HiperSockets	OS/390*	WebSphere*
	S/390*	xSeries
	SNAP/SHOT*	z/Architecture
		z/VM
		zSeries
		System z

* Registered Trademarks of IBM Corporation

The following are Trademarks or registered Trademarks of other companies.

LINUX is a registered Trademark of Linus Torvalds

Tivoli is a Trademark of Tivoli Systems Inc.

Java and all Java-related Trademarks and Logos are Trademarks of Sun Microsystems, Inc., in the United States and other countries

UNIX is a registered Trademark of The Open Group in the United States and other countries.

Microsoft, Windows and Windows NT are registered Trademarks of Microsoft Corporation.

SET and Secure Electronic Transaction are Trademarks owned by SET Secure Electronic Transaction LLC.

Intel is a registered Trademark of Intel Corporation.

Today's IT Environment

IT environments are increasingly heterogeneous and complex

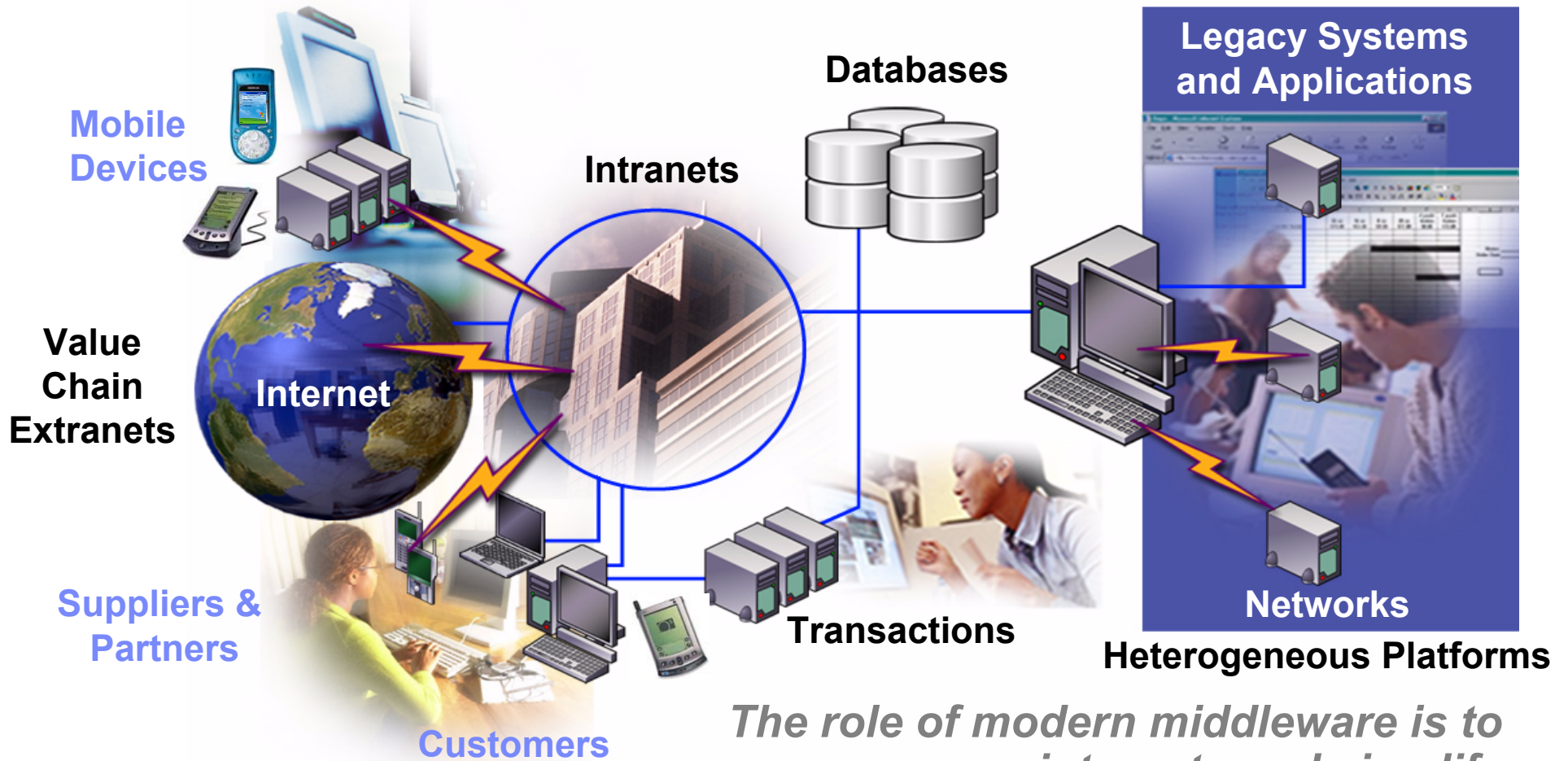

The role of modern middleware is to integrate and simplify

System z Operating Systems

Traditional Mainframe Operating Systems

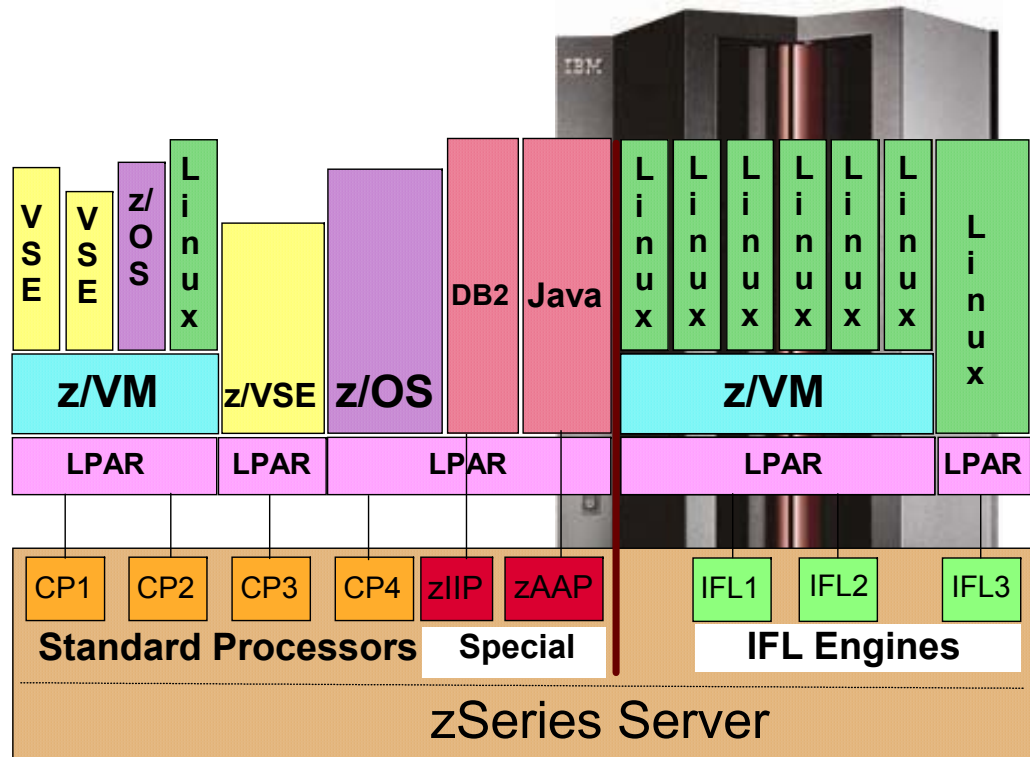
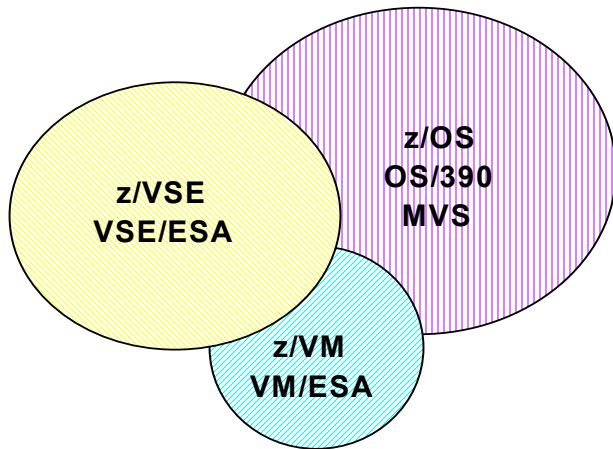

Standard Processors

- CP
 - For z/OS, z/VSE, z/VM workloads

Special Processors

- CF (Coupling Facility)
 - For Parallel Sysplex with z/OS
- IFL (Integrated Facility for Linux)
 - For Linux and Linux applications
- zAAP (zSeries Application Assist Processor)
 - For offload of Java applications from z/OS
- zIIP (zSeries System z9 Integrated Information Processor)

Agenda

- ■ **z/VSE V4 Announcement** 
- **z/VSE Strategy**
- **z/VSE Enterprize Modernization scenarios**

VSE Roadmap

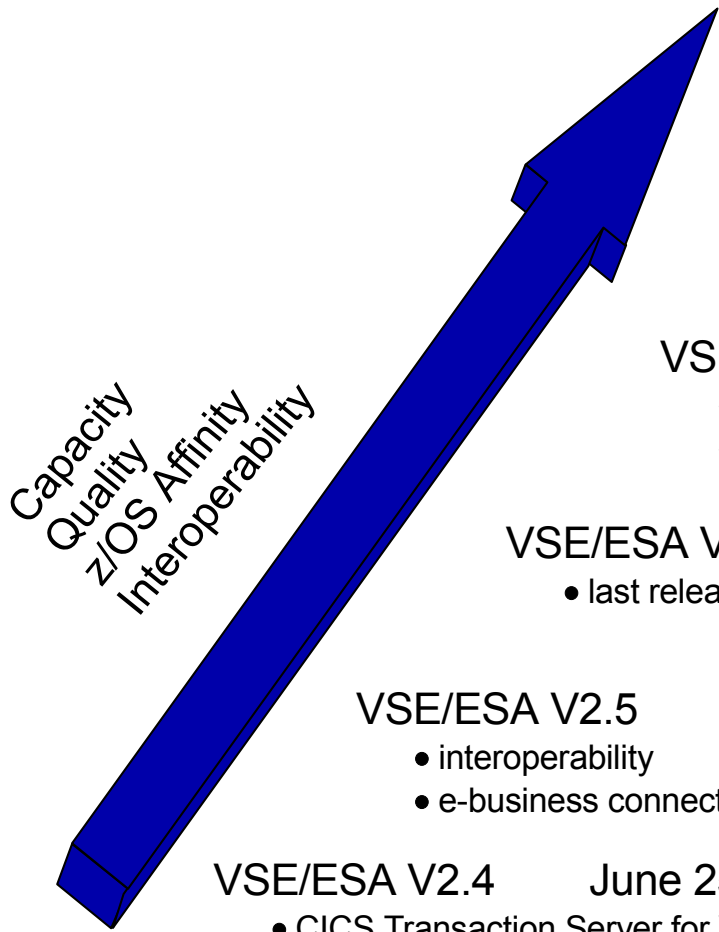

z/VSE V4 - GA 16. march 2007

- ***z/Architecture only***
- ***64-bit real addressing***
- ***SOD for sub-cap pricing***



z/VSE V3.1 March 4, 2005

- ***zSeries features, FCP/SCSI***
- ***31-bit mode only***

VSE/ESA V2.7 March 14, 2003

- ***enhanced interoperability***
- ***ALS2 servers only***



VSE/ESA V2.6 Dec 14, 2001

- ***last release to support pre-G5 servers***

VSE/ESA V2.5 Sept 29, 2000

- ***interoperability***
- ***e-business connectors***

VSE/ESA V2.4 June 25, 1999

- ***CICS Transaction Server for VSE/ESA***
- ***e-business***



z/VSE 4.1 – Announcements

- **z/VSE 4.1 preannouncement:**
 - ▶ **April 2006**

- **z/VSE 4.1 announcement**
 - ▶ **January 9. 2007**
 - ▶ **GA date announced for March 16. 2007**

- **New Pricing announcement for z/VSE 4.1**
 - ▶ **January 9. 2007**

- **Sub Capacity Pricing announcement for z/VSE 4.1**
 - ▶ **January 9. 2007**



VSE Server Support

IBM Servers	z/VSE V4.1	z/VSE V3.1	VSE/ESA V2.7
IBM System z9 Enterprise Class	Yes	Yes	Yes
IBM System z9 Business Class	Yes	Yes	Yes
zSeries 990, 890, 900, 800	Yes	Yes	Yes
S/390® Parallel Enterprise Server™ G5/G6	No	Yes	Yes
S/390® Multiprise® 3000	No	Yes	Yes
S/390® Parallel Enterprise Server™ G1/2/3/4	No	No	No
S/390® Multiprise® 2000	No	No	No
S/390® Integrated Server	No	No	No
P/390 and R/390	No	No	No
ES/9000 – 9221, 9121, 9021	No	No	No

VSE Service & Support Status

VSE Version and Release	Marketed	Supported	End of Support
z/VSE V4.1	from 03/2007	from 03/2007	tbd
z/VSE V3.1	Yes	Yes	tbd
VSE/ESA V2.7	No	Yes	02/2007
VSE/ESA V2.6	No	No	03/2006

z/VSE 4.1 – Base enhancements (1)

- **z/Architecture mode only**
- **64-bit real addressing for selected system functions**
 - ▶ **Designed to exploit up to 8GB of processor storage**
- **Up to 60 LPARS**
 - ▶ **30 LPARS on z9 BC**
 - ▶ **60 LPARS on z9 EC**
- **z/VSE 4.1 64-bit Enhancements**
 - ▶ **Power**
 - ▶ **IUI**
 - ▶ **Dump tools**

z/VSE 4.1 – Base enhancements (2)

- **OSA-Express2 OSN (Open System Adapter for NCP) support**
 - ▶ **The IBM Communication controller for Linux on System z emulates 3745 devices**

- **N_Port ID Virtualization (NPIV)**
 - ▶ **Designed to allow sharing of a single physical FCP channel among operating system images (in LPAR or VM)**

- **FCP point-to-point attachments**
 - ▶ **A FICON feature configured as CHIPID type FCP can directly attach to storage devices**

- **Program-directed re-IPL:**
 - ▶ **Operating systems running natively in an LPAR to trigger re-IPL**
 - **Exclusive available to z9 EC and z9 BC**

z/VSE 4.1 - Interoperability

■ VSAM FAT-BIG DASD support

- ▶ **Small DASD: (normal)** which has less than 64K tracks per volume
 - reported on LISTCAT as 3390 device.

- ▶ **Large DASD:** . The "Large DASD" will now have two subtypes:
 - **Big DASD:** the capacity of more than 64K tracks per volume
 - reported on LISTCAT as BIG-3390. VSAM can support up to 10017 cylinders on this device.

 - **Fat DASD:** which has up to 64K cylinders. – breaking barriers
 - VSAM is now breaking this barrier by introducing a new type of device
 - Reported on LISTCAT as FAT-3390

- ▶ A VSAM volume list must be of the same DASD type and cannot be mixed.

z/VSE 4.1 - Interoperability

■ VSAM to relational with VSAM Redirector

▶ Normalizing Database handler

- Store VSAM data in a normalized form into a relational database

▶ VSAM Capture Exit

- part of the VSAM Redirector. It captures all changes done in a VSAM cluster.
- creates a delta record in another VSAM cluster (that is a “delta file”)
- the delta record/message contains the data of the changed record and information about when (timestamp) and by whom (partition, phase name, origin value, etc.) the record was changed.
- **These data can be processed asynchronous by another program or system.**
 - for example using the VSE Connectors can be used to read the delta cluster and process the records
- **Alternatively, the Capture Exit can be used to create a MQ Message**

z/VSE 4.1 - Interoperability

- **WebSphere 6 compliant**
 - ▶ Support for newest Java Version
 - ▶ Support for newest Java Connector Architecture (JCA)

- **SOA**
 - ▶ Graphical Configuration Tool
 - ▶ SOAP Proxy Code Generator
 - ▶ Copybook Parser (COBOL, HLASM, PLI)

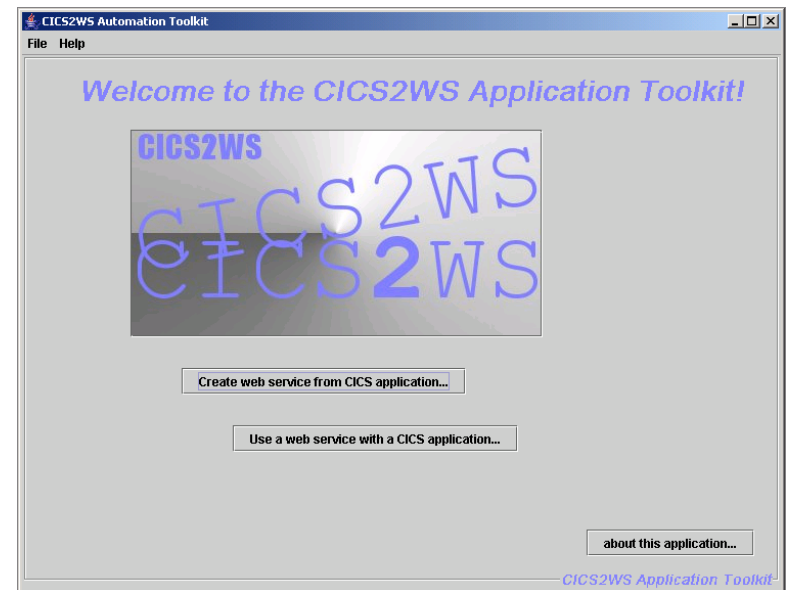

z/VSE 4.1 - Security

- **Security**
 - ▶ **Client Authentication: BSM Base**
 - ▶ **Client Authentication: Resource Protection**
- **Backup Concepts**
 - ▶ **Integration with Tivoli Storage Manager**
- **z/VSE Upgrade via FSU from VSE/ESA 2.7 and z/VSE 3.1**
- **Crypto**
 - ▶ **New CPACF ciphers supported with the IBM System z9 processor**
 - ▶ **Accelerator mode support for Crypto Express2 (CEX2A)**
 - ▶ **2048-bit support for Crypto Express2**
- **Encrypting tape drive - IBM System Storage TS1100 tape drive family**
 - ▶ **Standard feature on all TS1120 Tape Drives**
 - ▶ **Chargeable upgrade feature for existing TS1120 Tape Drives**
- **New pricing for z/VSE V4.1 and a Subcapacity Pricing Option**

IBM TS1120 Tape Drive Encryption

The industry's first comprehensive end-to-end tape encryption solution

- **First encrypting tape drive - IBM System Storage TS1100 tape drive family**
 - ▶ Standard feature on all TS1120 Tape Drives
 - ▶ Chargeable upgrade feature for existing TS1120 Tape Drives
- **A new, innovative IBM Encryption Key Manager component for the Java platform™ component supported on a wide range of systems including:**
 - ▶ z/OS, i5/OS, AIX, HP, Sun, Linux (incl System z), and Windows
- **Integration with IBM tape systems, libraries**
- **Enhancements to Tivoli Storage Manager to exploit TS1120 encryption**
- **Integration with System z encryption key, policy management, security and cryptographic capabilities**
- **Complements existing System z Encryption Facility for z/OS program product**
- **New services and consulting for tape data encryption and key management**



TS1120
500 GB
100 MB/sec

**Encryption Key
Manager**



IBM TS1120 Tape Drive Encryption – SOD for z/VSE

SOD*: “z/VSE V3.1 support of the TS1120 Tape Drive with encryption is planned for first half 2007. It is also IBM's intent to support z/VSE V4.1 (when made available) using Systems Managed Encryption with the TS1120. z/VSE support will require the Encryption Key Manager component running on another operating system other than z/VSE using an out-of-band connection.”

Centralized key management

- Help protect and manage encryption keys
 - Highly secure and available key data storage
 - Long term key management
 - Disaster recovery capabilities
- Single point of control
 - Non-VSE, Java-based platform
 - TCP/IP connection to tape control unit



**Data Encryption
in the Server**



**Data
Encryption in
TS1120**

- Highly secure
- High performance archive encryption
- Transparent to existing processes and applications
- Can help provide audit compliance

**TS1120 encryption
Enterprise scope**



* All statements regarding IBM's future direction and intent are subject to change or withdrawal without notice, and represent goals and objectives only.

z/VSE – comparison

■ Current Product: z/VSE 3.1

- ▶ z/VSE V3.1 (GA 3/2005)
- ▶ ESA/390 (31-bit) mode only
 - up to 2 GB real processor storage
- ▶ supports
 - System z9 EC *and* z9 BC
 - eServer zSeries 990, 890, 900, 800
 - **Multiprise 3000 & S/390 G5/G6**
- ▶ HiperSockets
- ▶ CPACF
- ▶ Crypto Express2 (configurable)
- ▶ FCP/SCSI disks & NPIV
 - DS8000, DS6000, ESS
- ▶ FICON Express2 & 4
- ▶ OSA Express2
- ▶ 31-bit buffers for ACF/VTAM
- ▶ SOD for TS1120 encrypting tape

■ Future Product: z/VSE 4.1

- ▶ z/VSE V4.1 (GA 16/3/2006)
- ▶ z/Architecture (64-bit) mode only
 - up to 8 GB real processor storage
- ▶ supports
 - System z9 EC *and* z9 BC
 - eServer zSeries 990, 890, 900, 800
- ▶ New pricing (MWLC)
- ▶ Subcapacity pricing option (z9 only)
- ▶ HiperSockets
- ▶ CPACF + **enhancements**
- ▶ Crypto Express2 (configurable)
- ▶ FPC/SCSI disk & NPIV + **point-to-point**
 - DS8000, DS6000, ESS
- ▶ FICON Express2 & 4
- ▶ OSA Express2
- ▶ 31-bit buffers for ACF/VTAM
- ▶ TS1120 encrypting tape

Agenda

- **z/VSE V4 Announcement** 
- ■ **z/VSE Strategy**
- **z/VSE Enterprize Modernization scenarios**

z/VSE Strategy 'easy as P I E'



Protect

existing investment

- Continue to run existing core applications unchanged
- Continuous follow-on development for HW and SW
 - from S/390 via zSeries to IBM System z9
 - from VSE/ESA to z/VSE
- z/VSE is the platform of choice for transaction oriented core applications with CICS
- Excellent support from IBM Lab in Boeblingen
 - z/VSE worldwide development is located in Boeblingen --> deep skills available
 - PoC – Proof of Concept (customer individual)
 - Briefings (customer individual)

Integrate

with IBM middleware using connectors

- Integration of VSE into heterogeneous environments
- z/VSE is a very stable operating system that can easily be connected to open systems (Linux)
 - access to external data (e.g. on Linux) or programs (e.g. Java) via standard connectors or via free of charge VSE specific connectors
 - exploitation of HiperSockets within the server – no physical network outside the box

Extend

with Linux on System z

- Extension of existing solutions with Linux on System z
- Cooperation and coexistence with Linux on System z and z/VM
- z/VSE is open and connectable to various different client/server platforms



VSE's interoperability is open for various platforms !

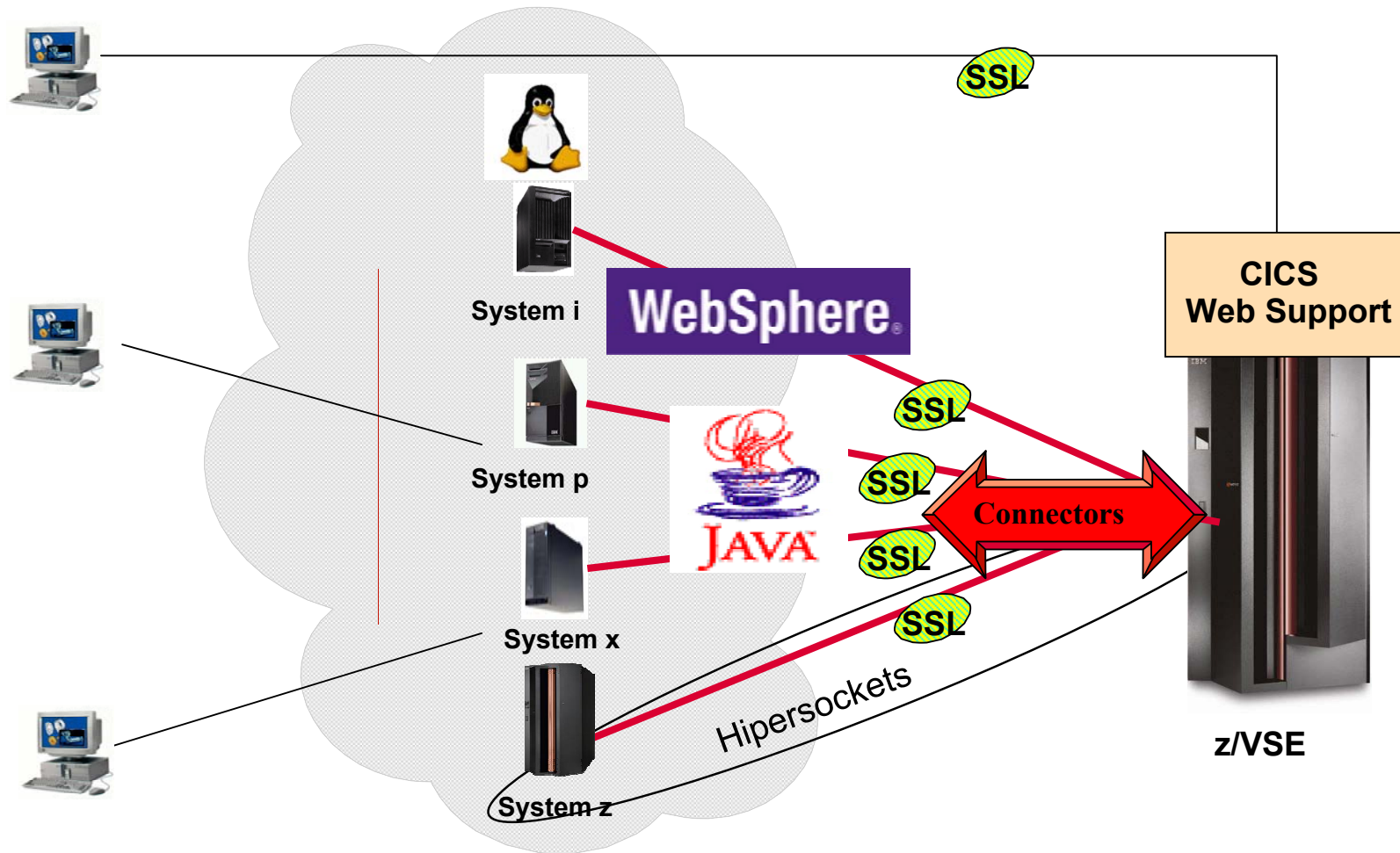

VSE Strategy

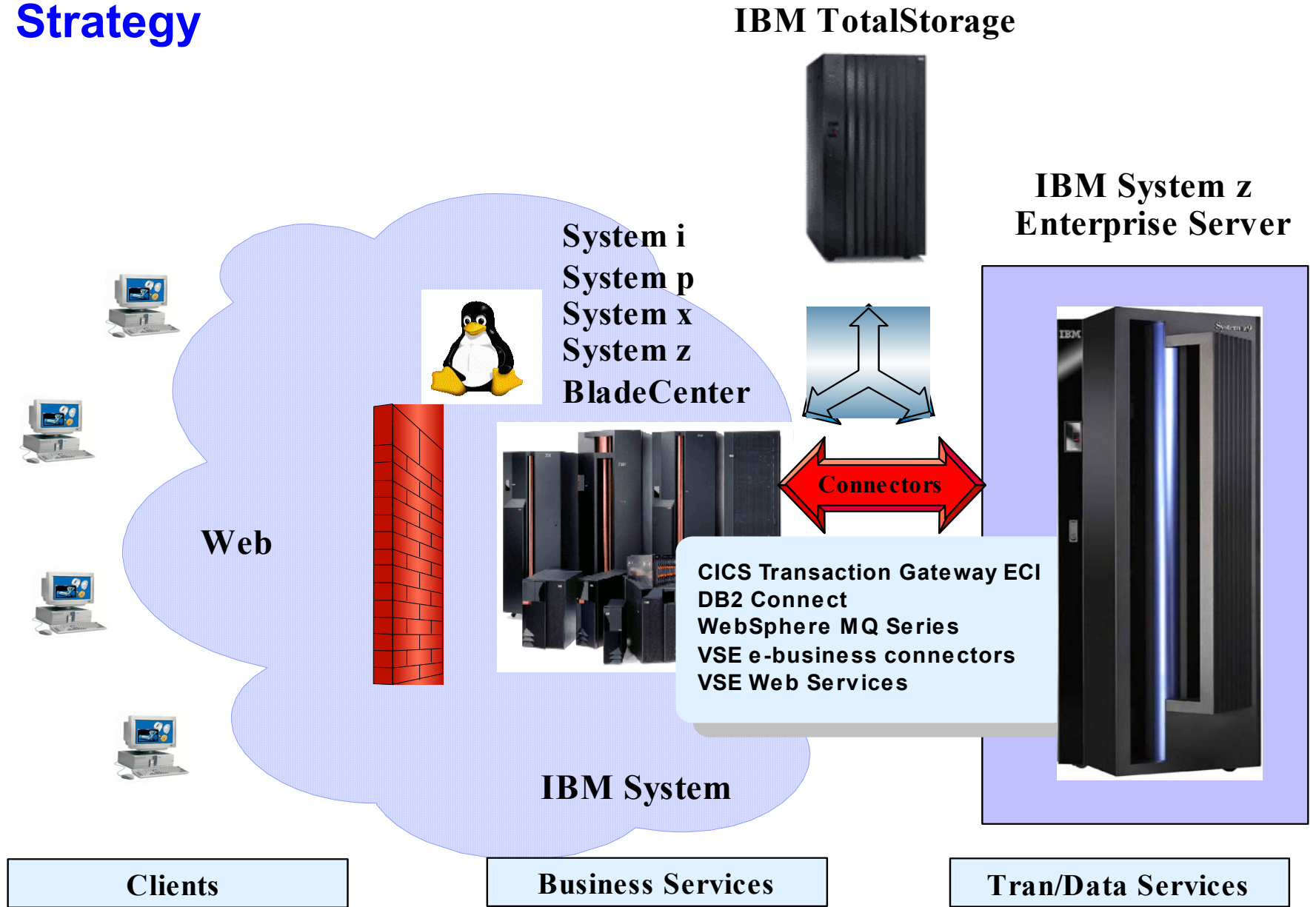

VSE Strategy with Linux on System z

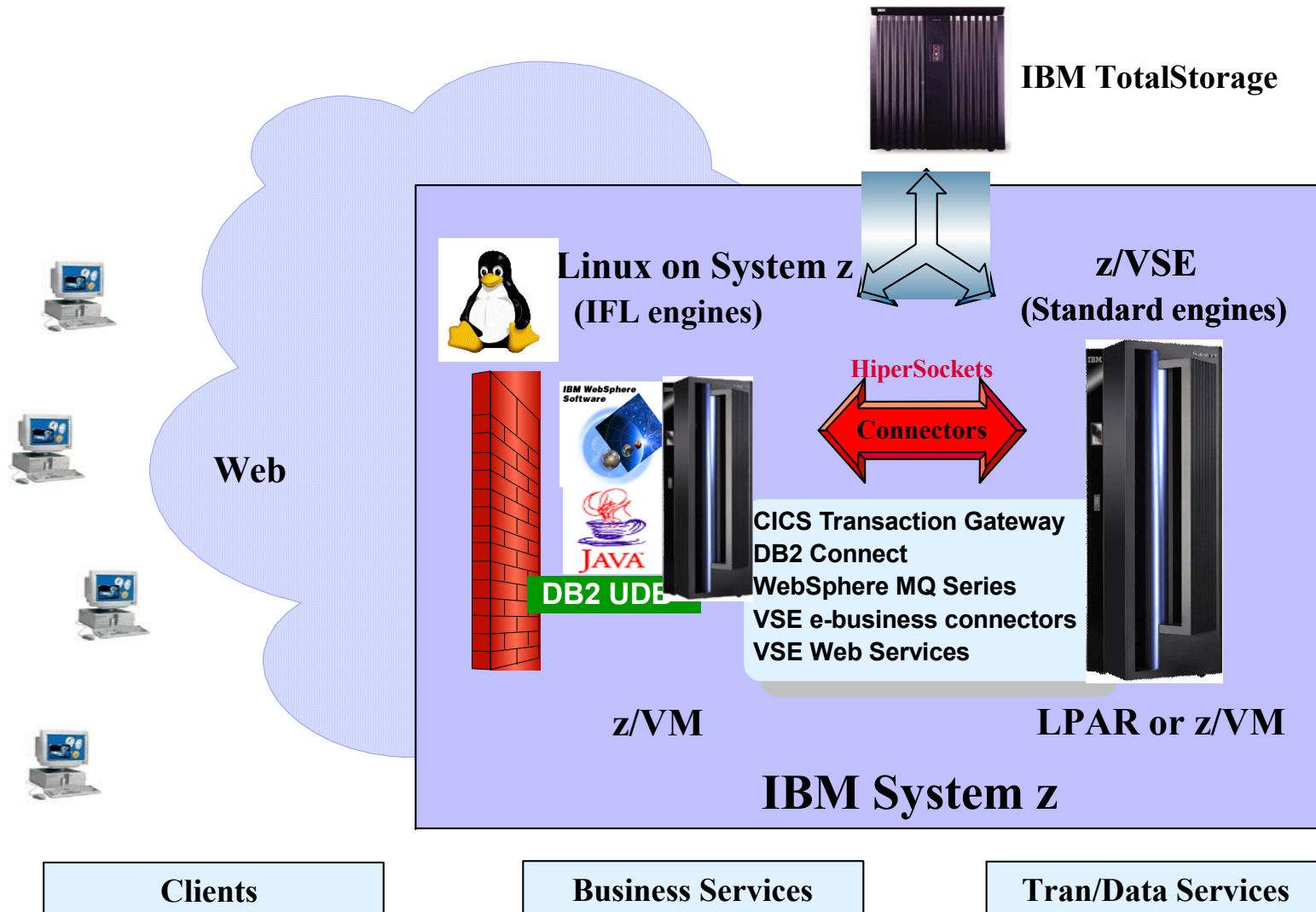

Agenda

- **z/VSE V4 Announcement** 
- **z/VSE Strategy**
- ■ **z/VSE Enterprize Modernization scenarios**

Typical VSE Customer Environment

- Various different servers (System z, System p, System i, System x, and others)
- VSAM data on VSE (some DB2 environments, some other databases)
- Relational databases on distributed platforms (DB2, Oracle, others)
- **Data exchange is primarily done via FTP**
- **Almost NO real time data access/exchange**

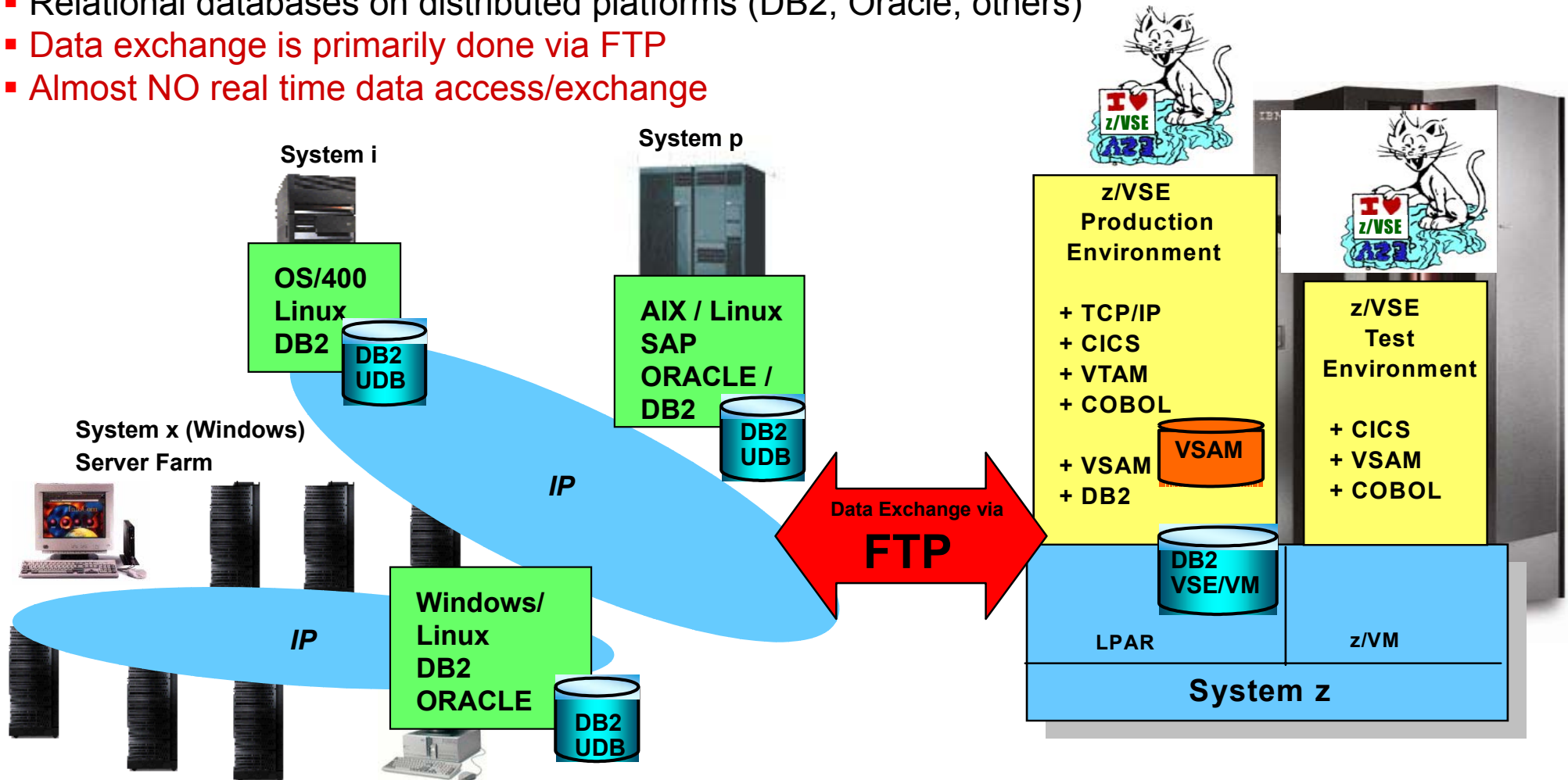

Most important requirement: Access to new applications!

Middleware Relations to z/VSE

- Modern Applications with Linux on zSeries
- Most modern Technologies interact with VSE Services
- Modernisation of IT Infrastructures using Real-time access to data

 - part of VSE

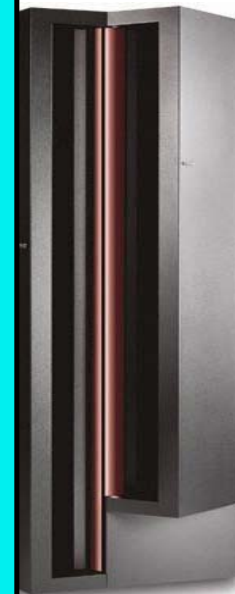
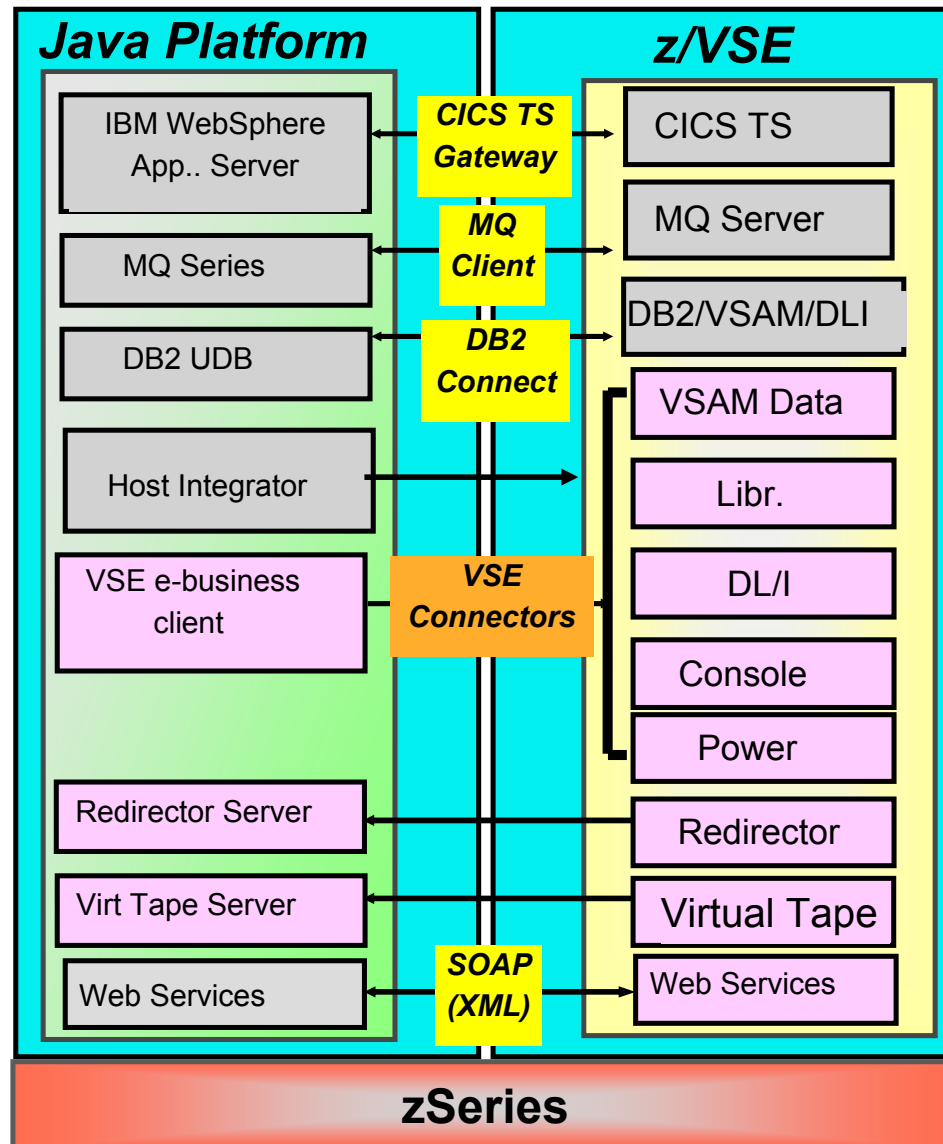

Scenario 1: DB2 UDB (64-bit) for VSE Customers

Data consolidation and data warehouse solutions with DB2 UDB on System z

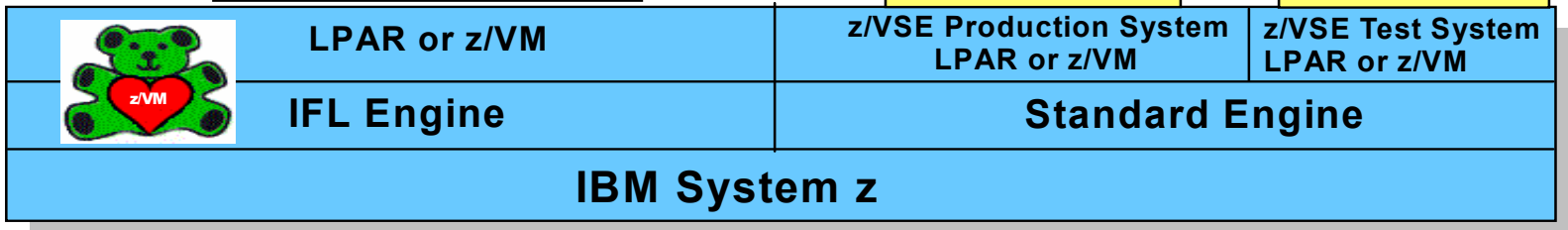
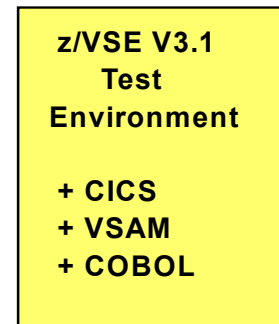
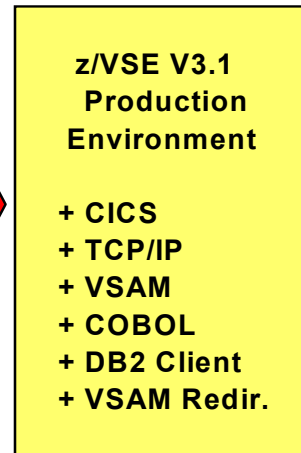
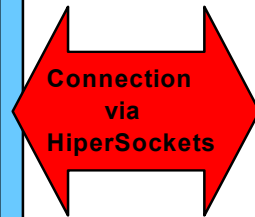
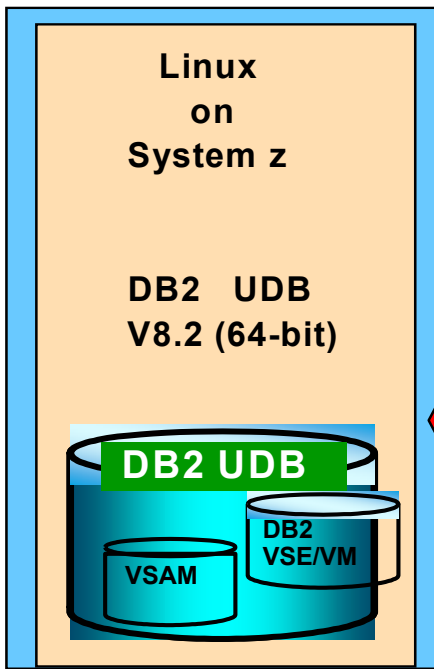

DB2 Scenarios – with DB2 UDB on Linux

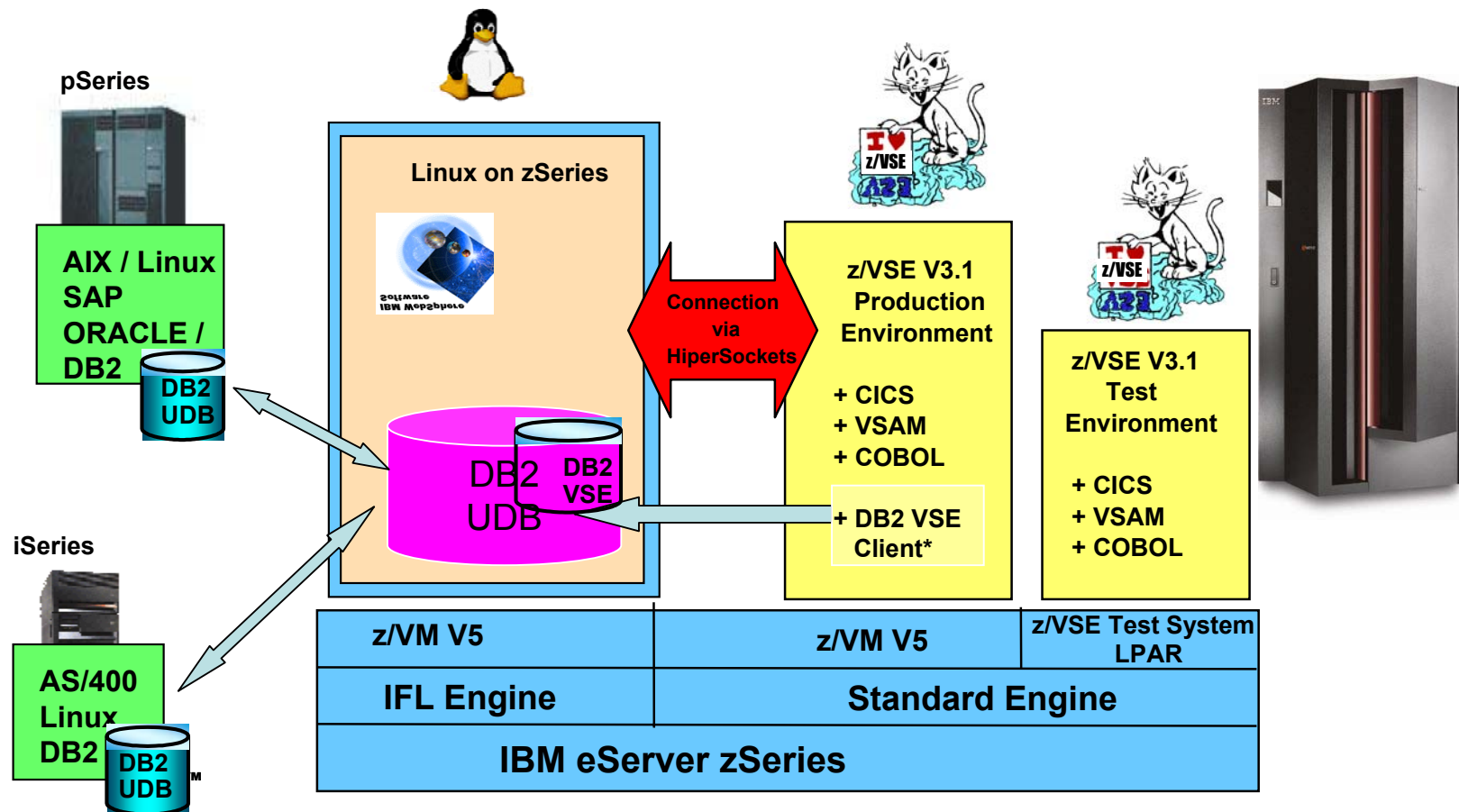

(*) DB2 VSE Client – the client functionality only, can be obtained with PRPQ P10154

Common Data Store – Transparent Work of VSAM Programs with DB2 UDB on Linux on System z

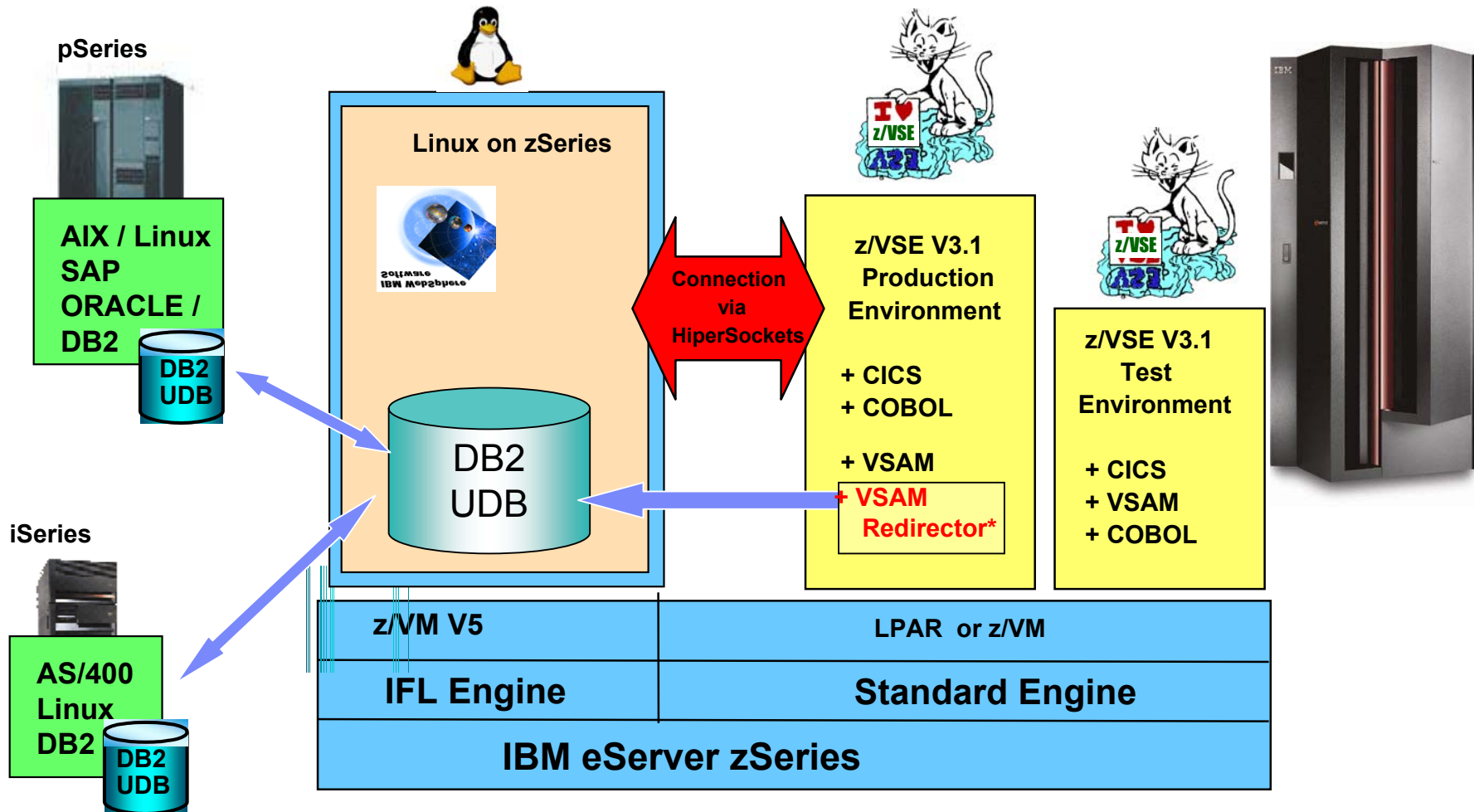

(*) VSAM Redirector – Common data store solution – with DB2 on Linux on zSeries Solutions without changes to VSAM programs

Data propagation / synchronization from VSE

VSE/VSAM Redirector can use normalized VSAM data

► No changes to the existing VSE applications

► **The new Redirector Handler in z/VSE 4.1 can store/retrieve 'VSAM' data in multiple DB Tables .**

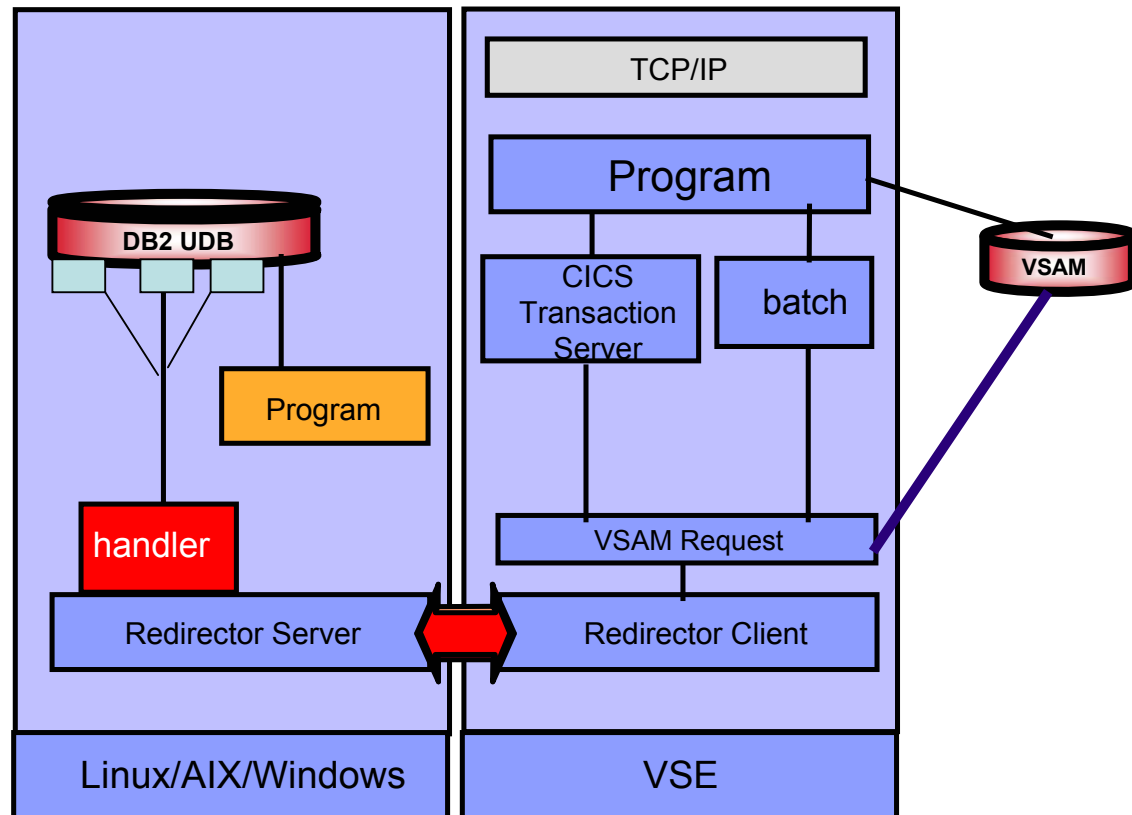

- Applications on VSE should be able to access DB2 data on Linux
- Synchronization of DB2 UDB on Linux with VSAM using VSAM Redirector.
(VSAM Redirector is part of VSE)

Common Data Store – Transparent Work of VSAM Programs with DB2 UDB on Linux on System z

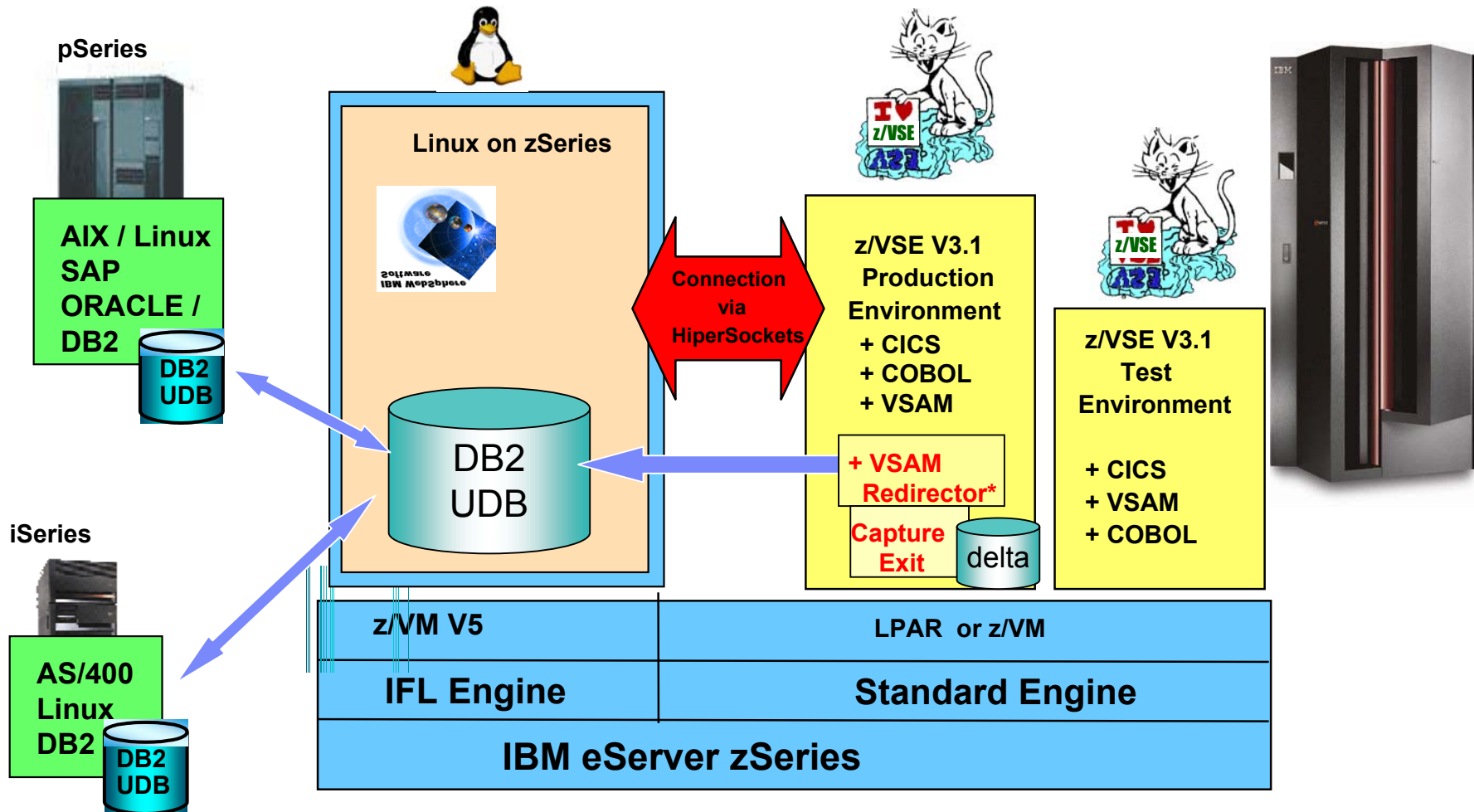

(*) VSAM Redirector – Common data store solution – with DB2 on Linux on zSeries Solutions without changes to VSAM programs

Redirector Capture. Architectural View

New in z/VSE 4.1

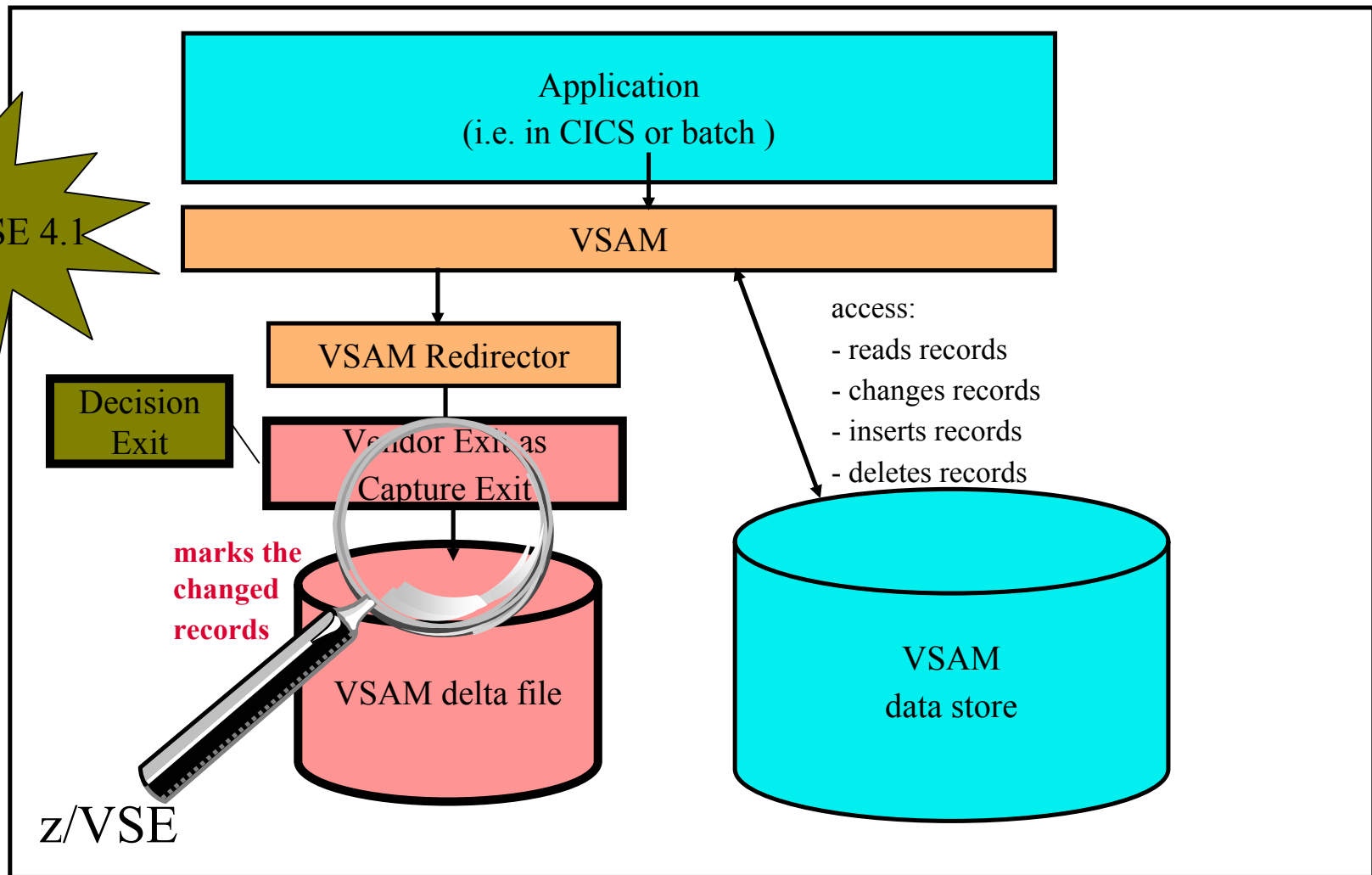

Solution with z/VSE 4.1

Incremental, Linux driven updates

► With VSAM Capture – the performance of the VSE production system protected

► The changes are processed asynchronously and not influencing the production system

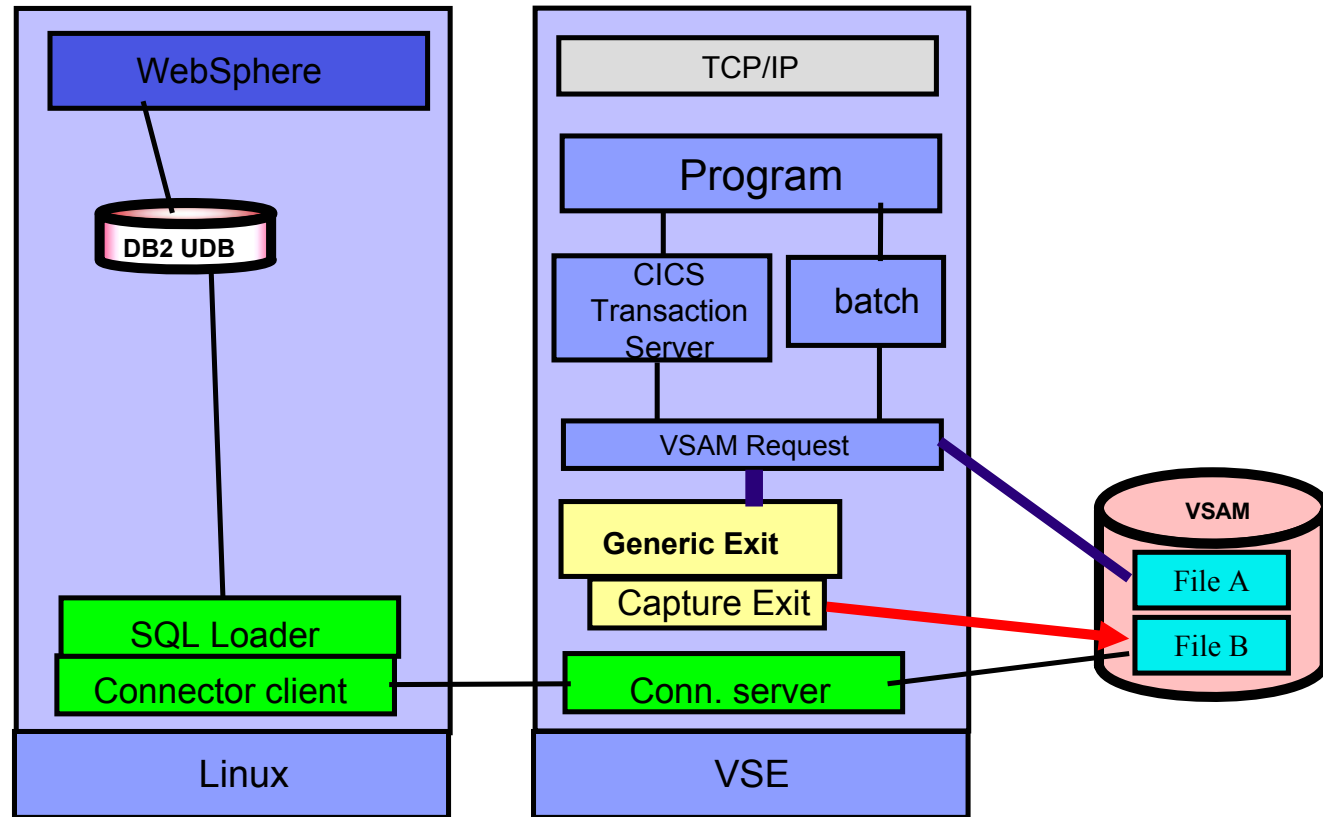

- Collect the changed records in a separate VSAM file
 - Possibility of cleansing
- Process them – with the VSE Connectors

VSAM Redirector Capture

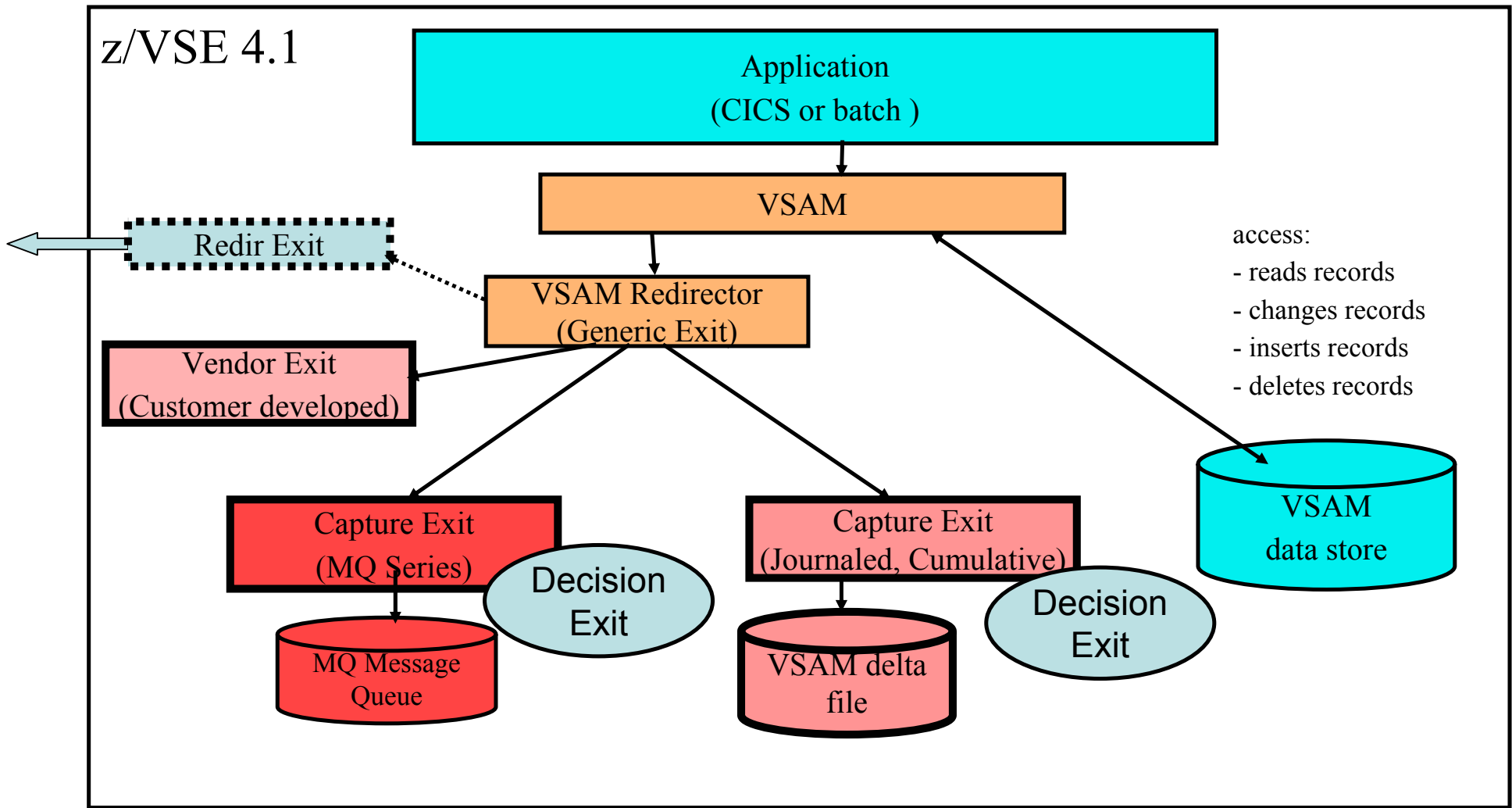

WebSphere MQ Series Solutions with z/VSE

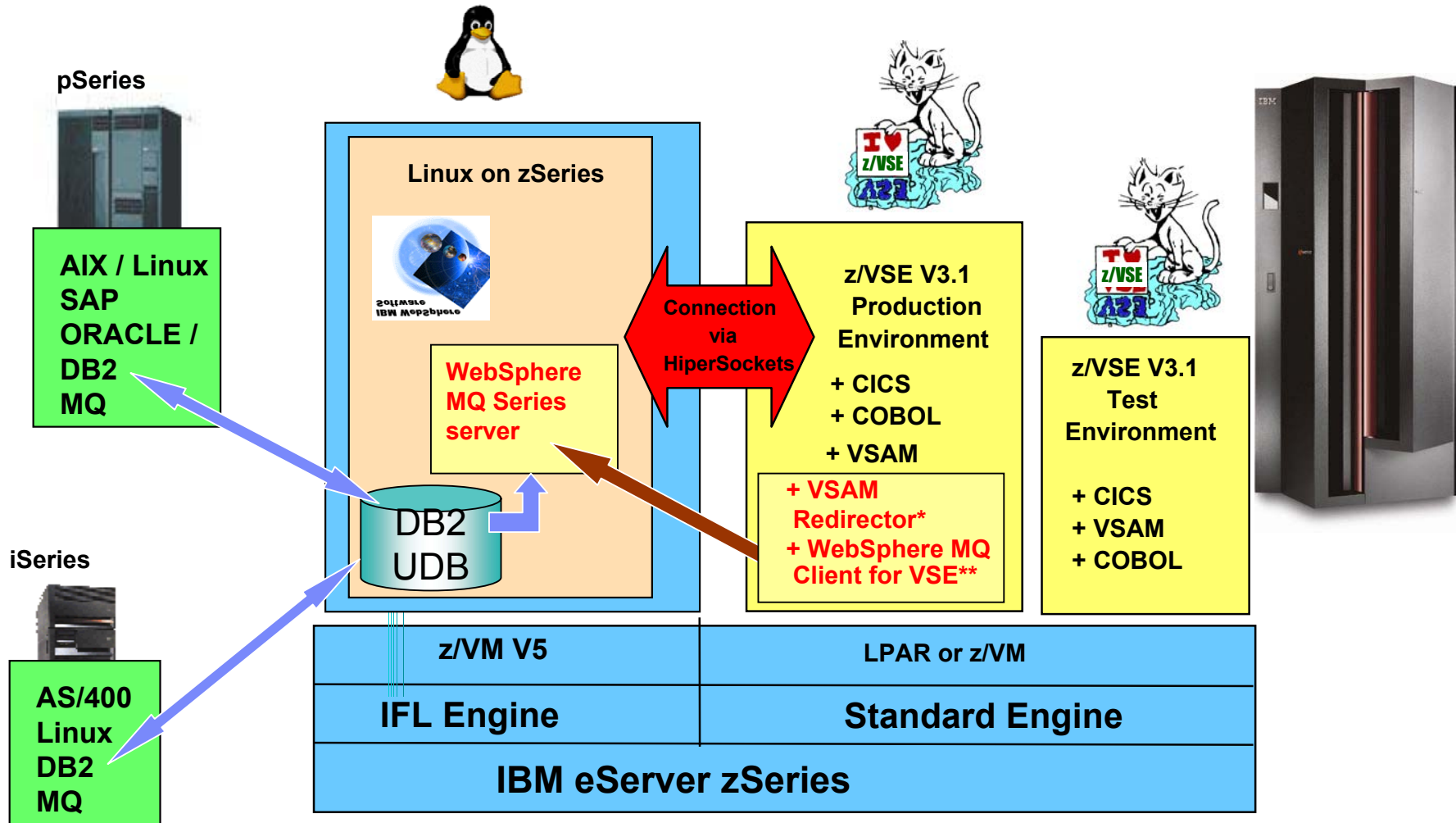

(*) **VSAM Redirector + Redirector MQ Exit** allows MQ Solutions without changes to VSAM programs

(**) **WebSphere MQ Client for VSE** is brand-new and free of charge

Scenario 2: „Webification“ for VSE Applications

Web enable existing applications with Inter/Intranet frontend

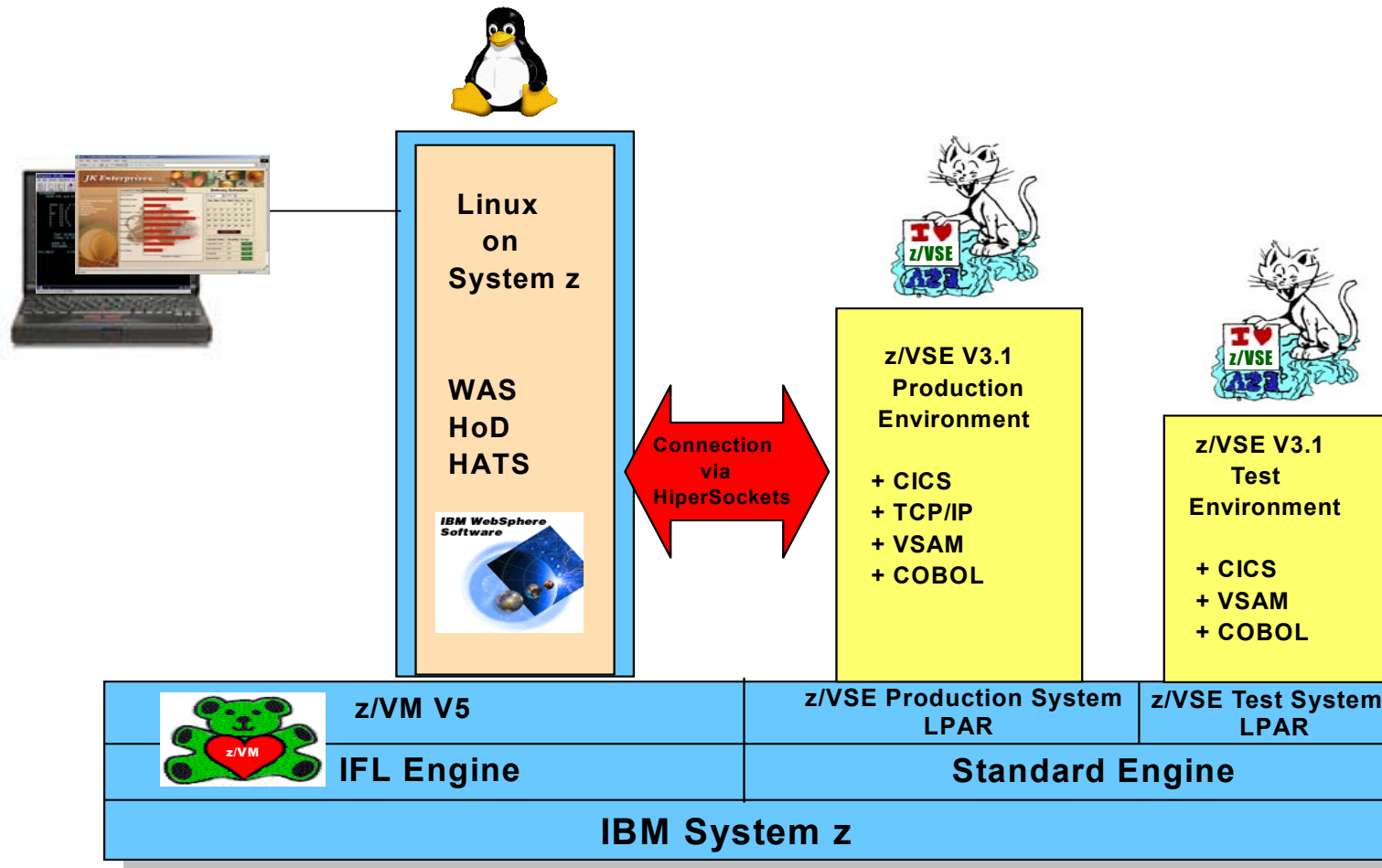

Scenario 3: WebSphere Portal for VSE Customers

A portal for administration and integration of applications for employees / customers / providers

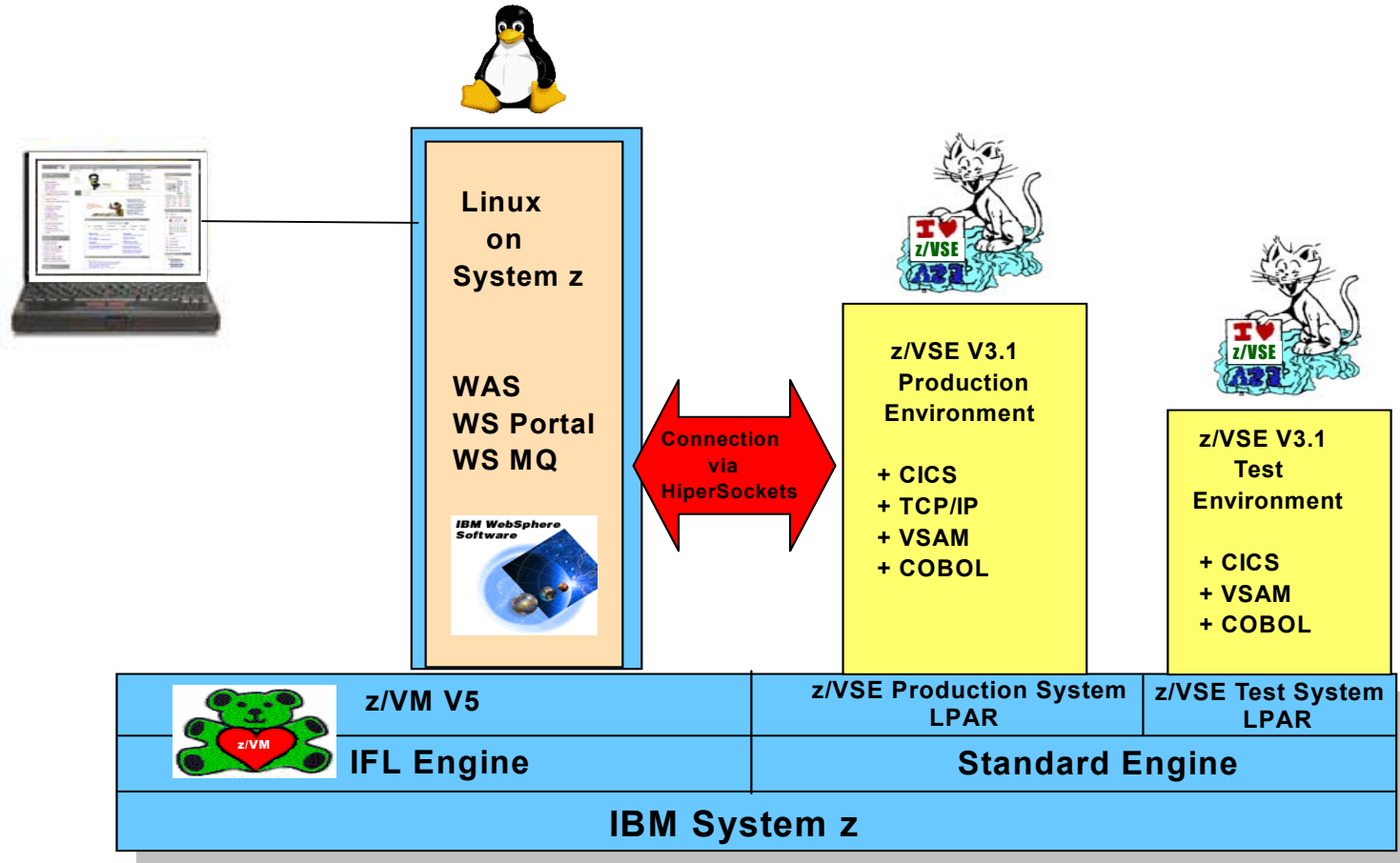

Scenario 4: Network Infrastructure Simplification

3745/46 (NCP) and TN3270 replacement with Linux on System z

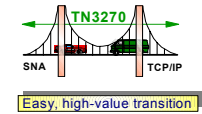
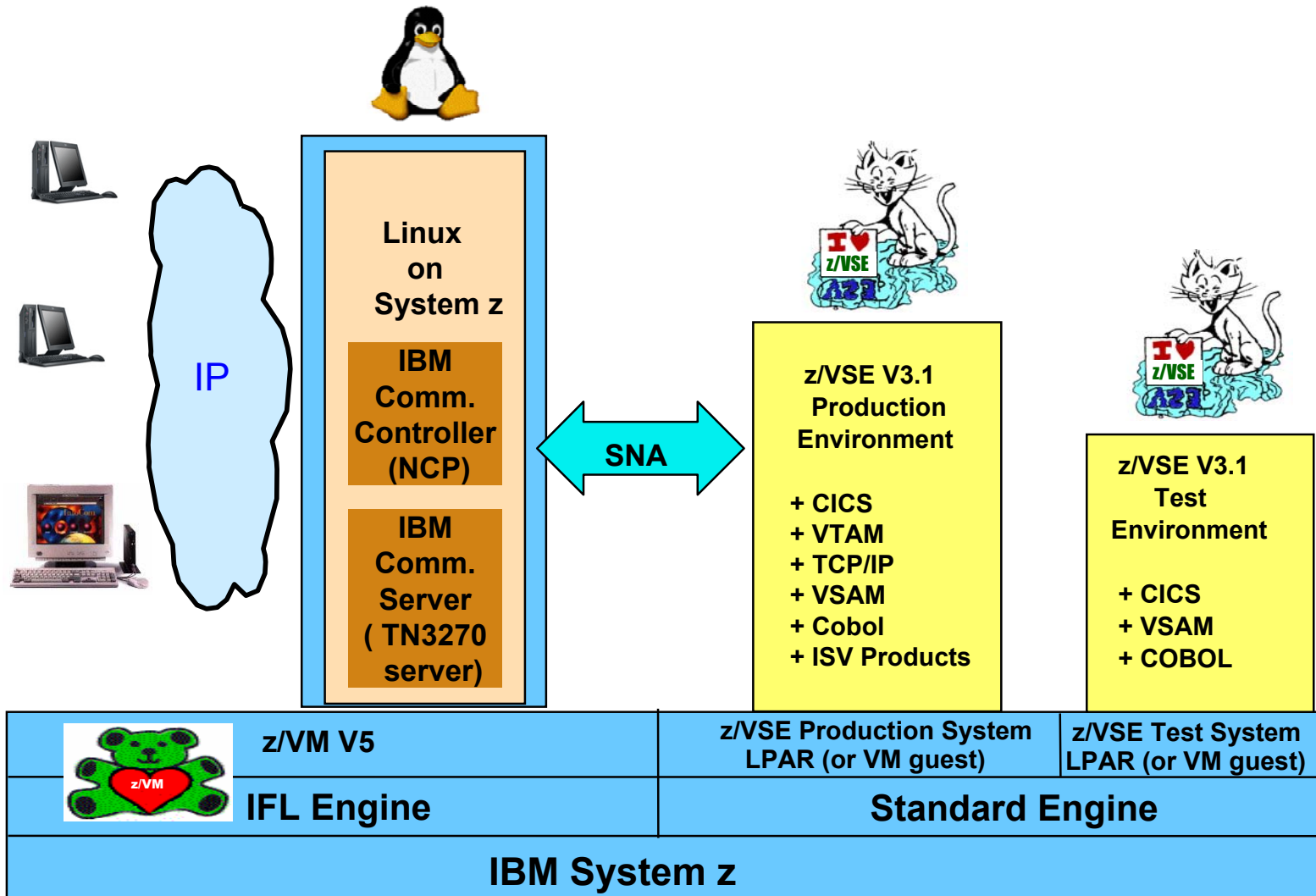

Scenario 5: Backup/Restore Concepts for VSE

Integrate z/VSE with TSM on Linux on System z

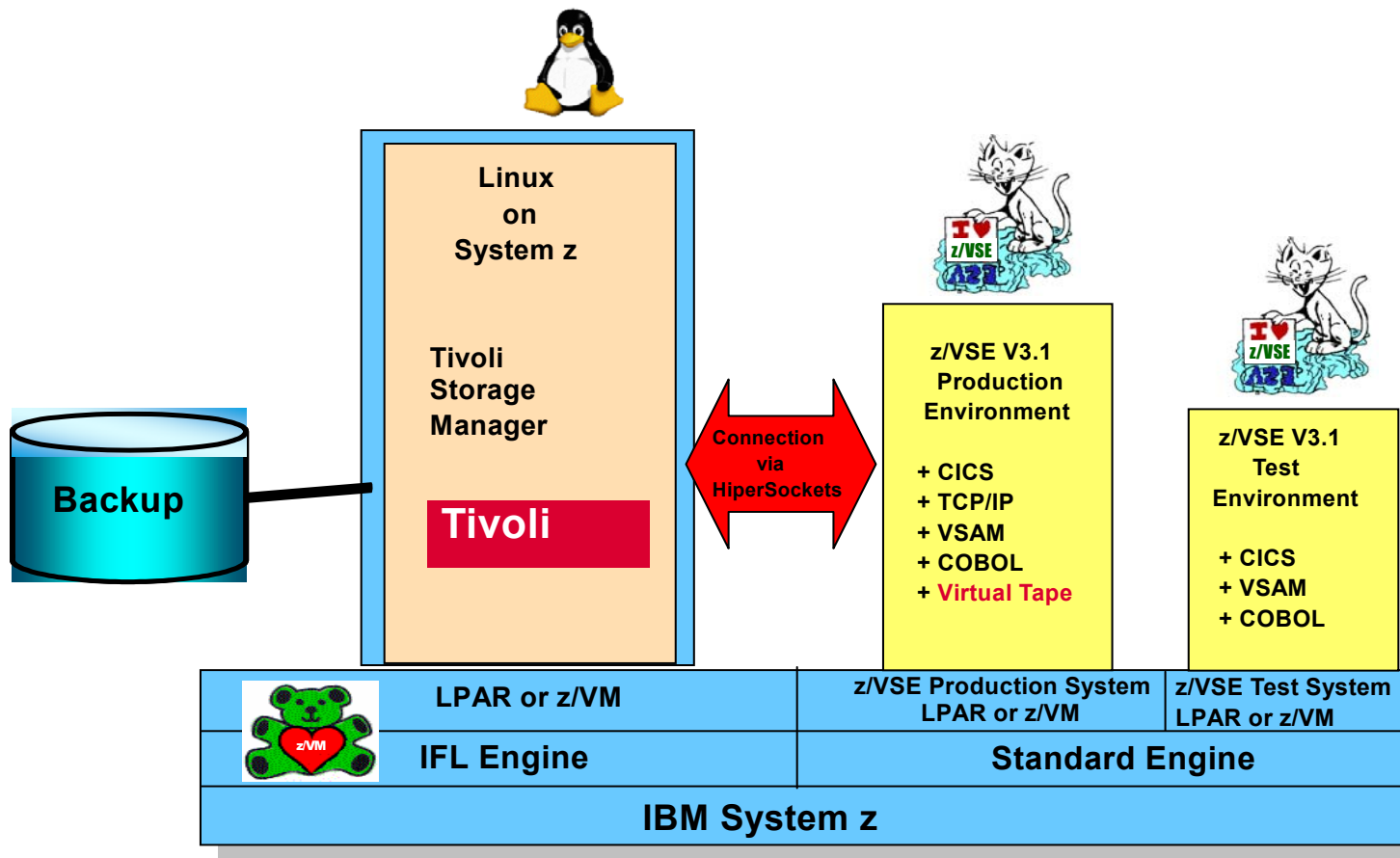

Scenario 6: SOA and Web Services with z/VSE

Application integration

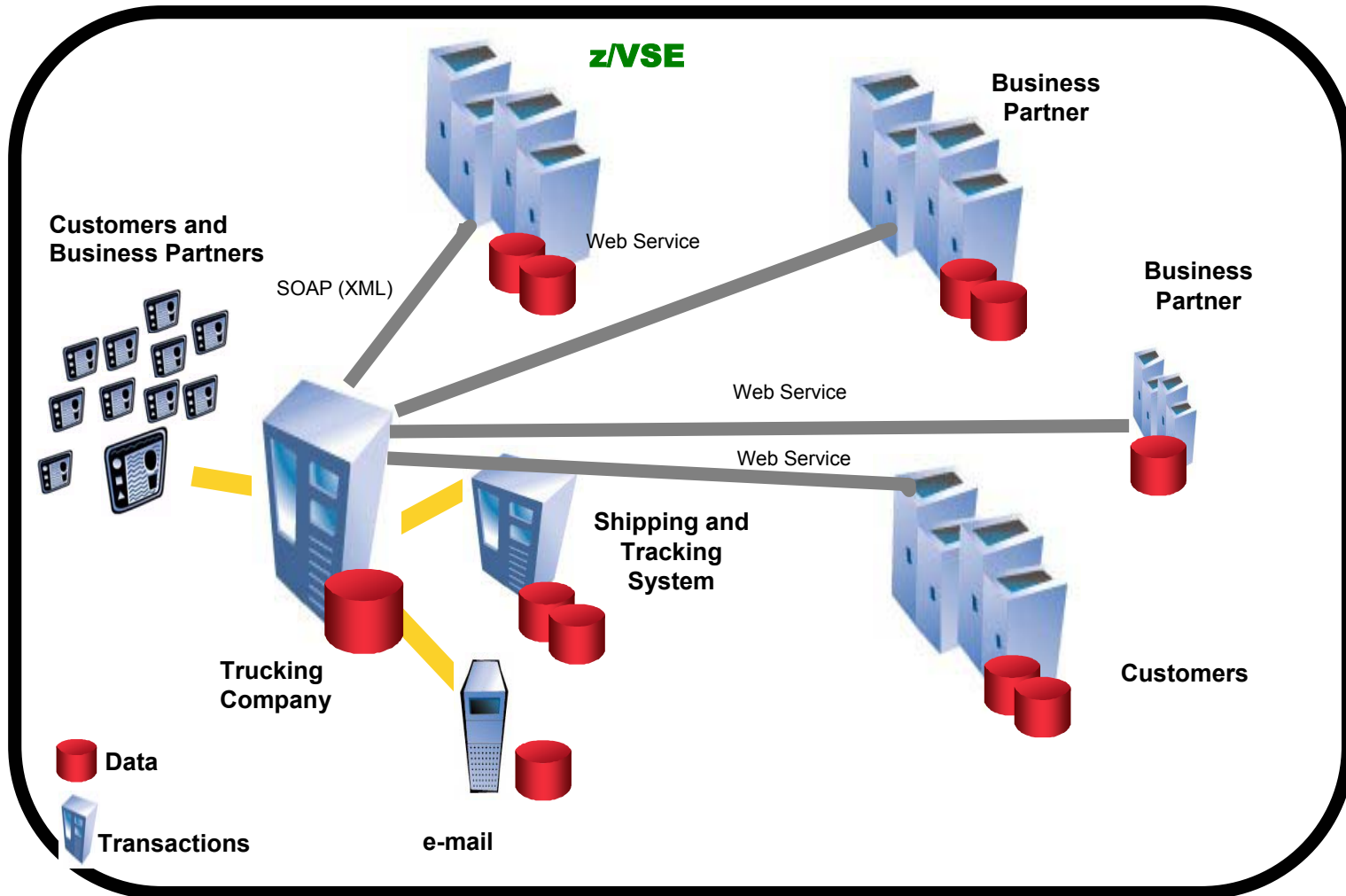

Web Services with z/VSE

SOA and XML data interchange with CICS transactions

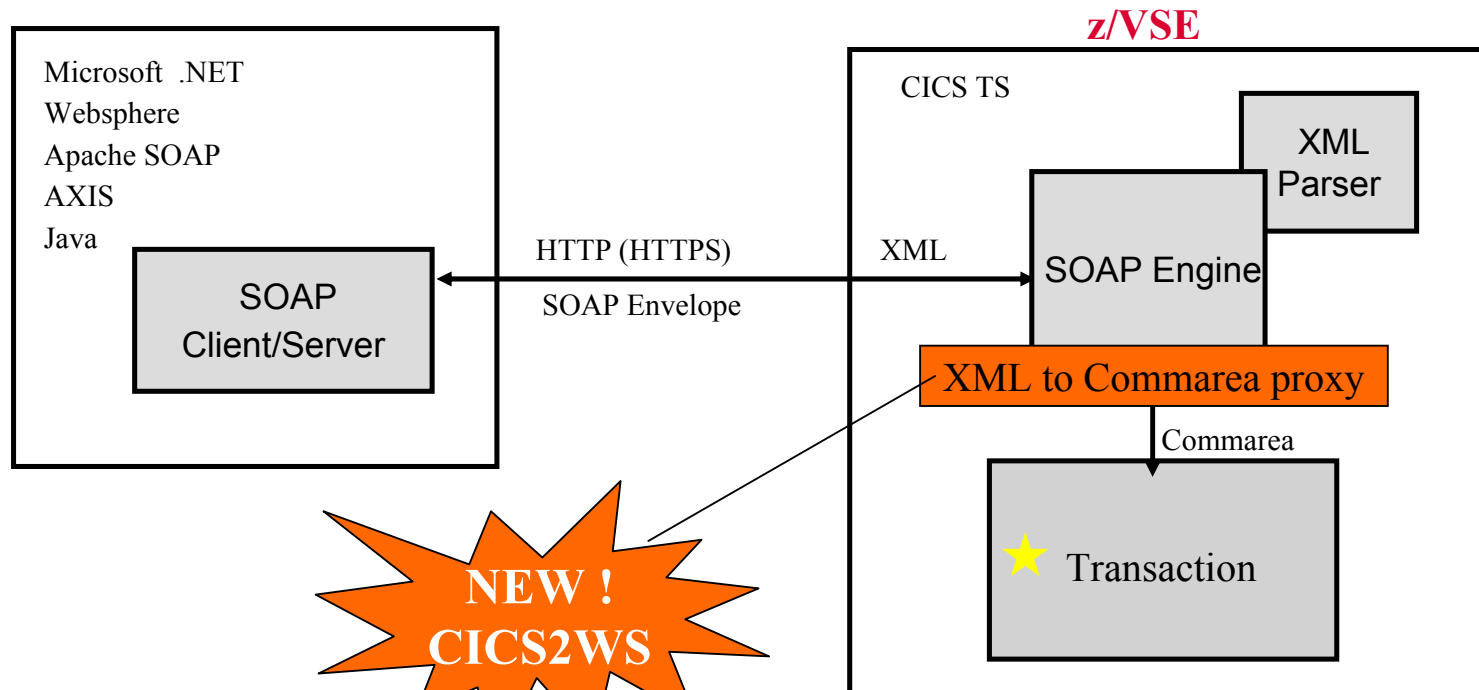

NEW!
CICS2WS

★ VSE Transactions as Web Service – generated with the tool CICS2WS

Application development for VSE

(1) Use of modern development environments !

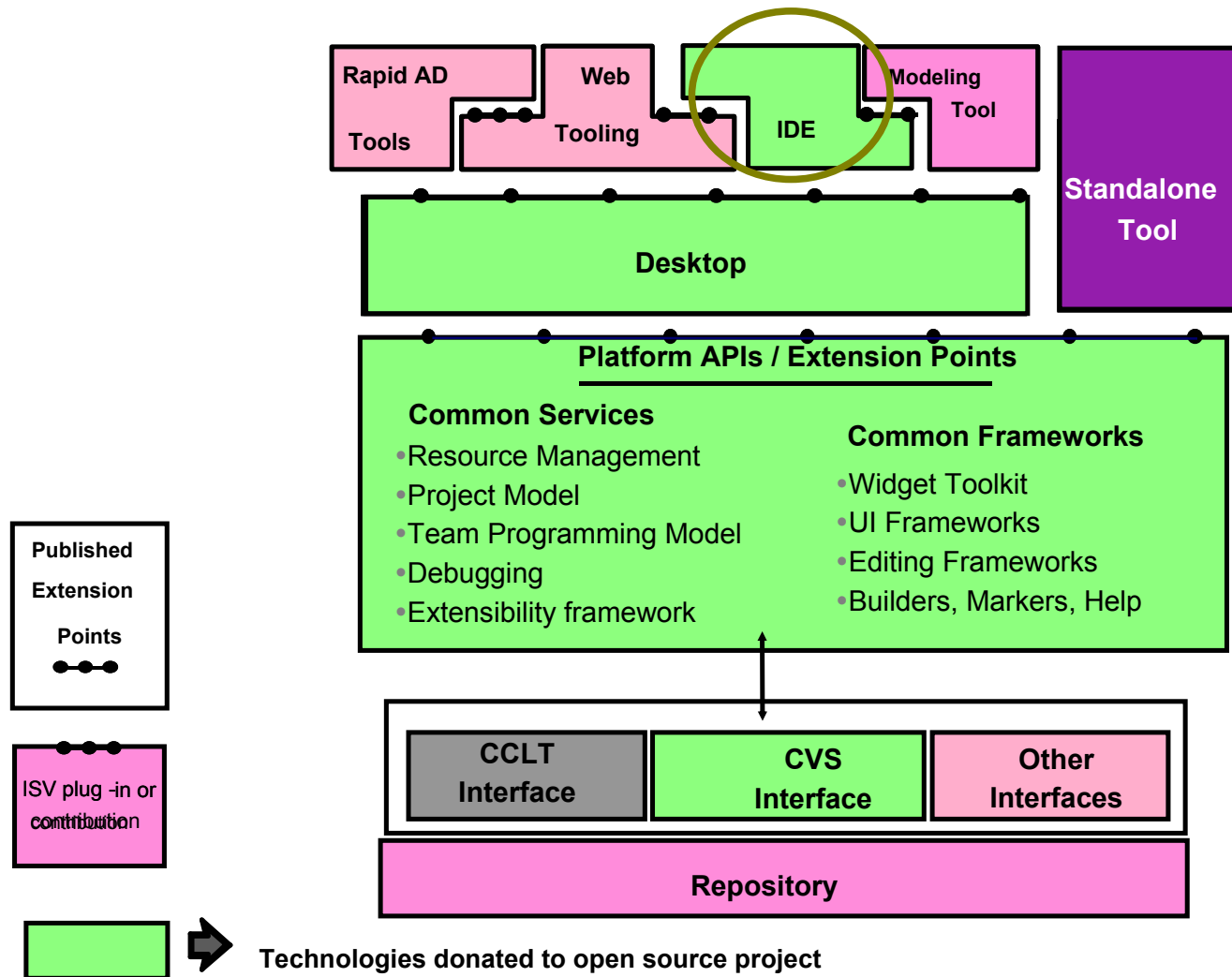

(1) Cross Platform Integrated Development Environment Approach with WebSphere Developer for System z (*)

(*) In development.

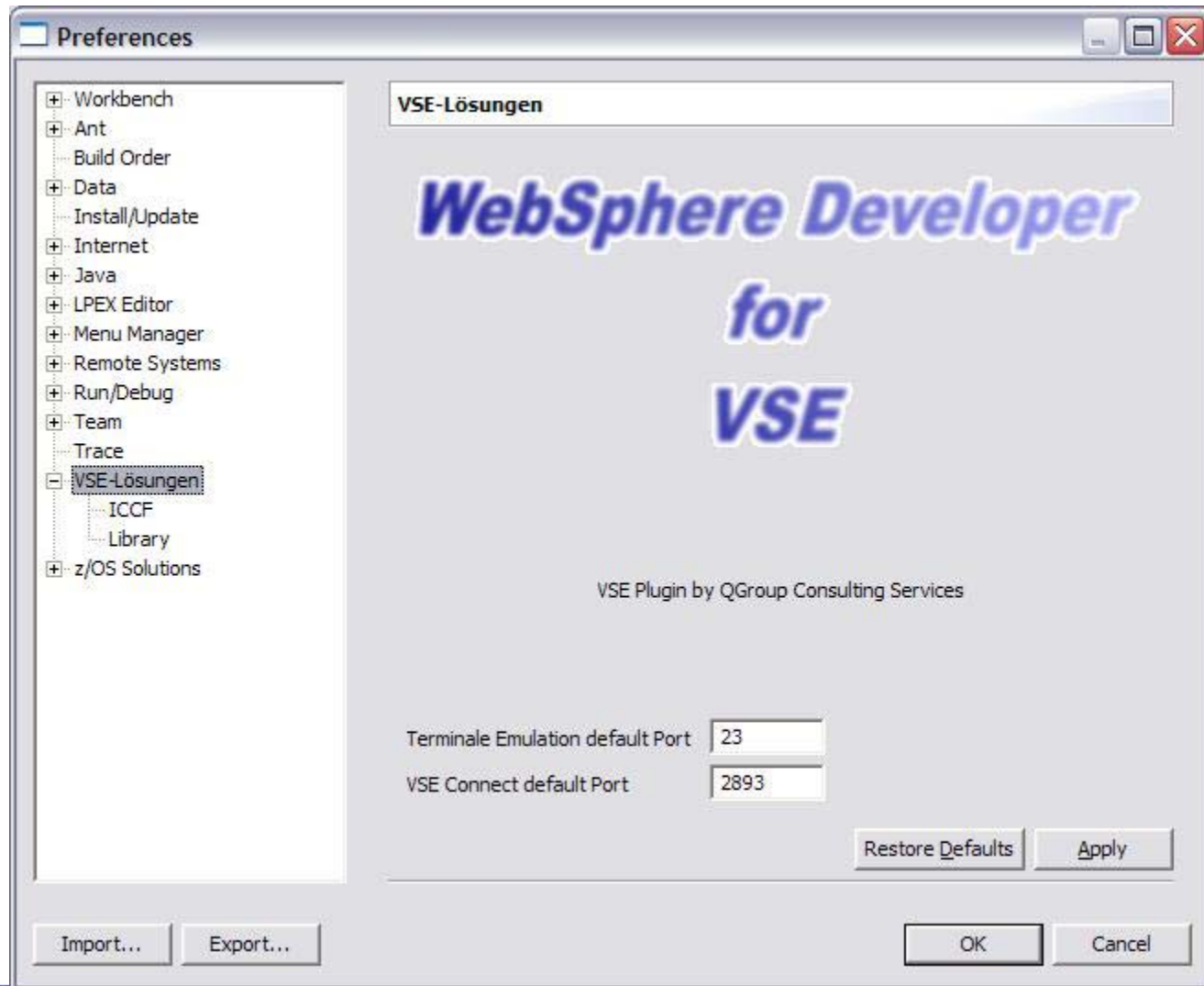

The screenshot displays the IBM VSE development environment. The main window is titled "VSE - IGZTMATH.cbl" and contains a code editor with the following content:

```

Line 40      Column 81      Insert
--*A-1-B-----2-----3-----4-----5-----6-----7--|-----8
02 Condition-Token-Value.          00027000
COPY CEEIGZCT.                    00028000
03 Case-1-Condition-ID.            00029000
04 Severity PIC S9(4) BINARY.      00030000
04 Msg-No PIC S9(4) BINARY.        00031000
03 Case-2-Condition-ID            00032000
   REDEFINES Case-1-Condition-ID.  00033000
04 Class-Code PIC S9(4) BINARY.    00034000
04 Cause-Code PIC S9(4) BINARY.    00035000
Case-Sev-Ctl PIC X.                00036000
Facility-ID PIC XXX.               00037000
Info PIC S9(9) BINARY.             00038000
                                   00039000
VI SION.                            00040000
                                   00041000
                                   00042000
                                   00043000
5 TO ARG1RS.                         00044000
ESSLOG' USING ARG1RS, FC, RESLTRS.   00045000
*****                                00046000
    
```

A context menu is open over the code editor, listing various actions such as "New", "Go Into", "Go To", "Open", "Open With", "Refresh", "Expand", "Collapse", "Rename...", "Copy", "Move...", "Delete...", "Search...", "Run", "Debug", "Team", "Compare With", "Replace With", "VSE", "Host Connection Emulator Support", "Local Syntax Check", "Nominate as Entry Point(B)", and "Open Welcome Page(Q)". The "VSE" option is currently selected, and a sub-menu is visible with "RemoteCompile", "Info", and "Upload" options.

The left sidebar shows a project explorer with a tree view containing folders like ".TmpVseRemote", "DEMOVSE", "BuildOutput", ".project", and files like "CEEIGZCT.cbl" and "IGZT...". Below the project explorer is a "Property" window with tabs for "Info" and "Prop".

The right sidebar shows a "VSE System View" window with a list of system components, including CEEIGZCT.C, CEEIGZDT.C, CEEIGZLC.C, CEEIGZNM.C, CEEIGZTD.C, EDCCCB.C, EDCCCB2.C, EDCCICS.C, EDCCMI.C, EDCCPL.C, EDCCRHP.C, EDCCSIG.C, EDCCWIN.C, EDCCZST.C, EDCCDATE.C, EDCCDATM.C, EDCCDAYS.C, EDCCCOD.C, EDCCDIVX.C, EDCCDIVZ.C, EDCCDISHP.C, EDCCDT1.C, EDCCDT2.C, EDCCDT3.C, and EDCCDT4.C.

At the bottom, a "Problems" window is open, displaying a table of error messages:

Page	Se...	Line	Location	Host Name	Date		
S2106-S	"DIVI"	was found in the "VALUE" stat...	2	40	/DEMOVSE/IGZTMATH...	Local	Jan 26, 2007 4:39:27 PM

The Windows taskbar at the bottom shows the system tray with a battery level of 98%, the time 4:40 PM on Friday, 1/26/2007, and several application icons including the Start button and a taskbar with "VSE - IGZTMATH.cbl" and "localSyntaxcheckErro...".

VSE - IGZTMATH.cbl -

File Edit Navigate Search Project Run Window Help

z/OS Projects

- .TmpVseRemote
- DEMOVSE
 - build
 - BuildOutput
 - jd
 - .project
 - CEEIGZCT.cbl
 - IGZTMATH.cbl

DEMOVSE.hce IGZTMATH.cbl

VSE System View

- CEEIGZCT.C
- CEEIGZDT.C
- CEEIGZLC.C
- CEEIGZNM.C
- CEEIGZTD.C
- EDCCCB.C
- EDCCCB2.C
- EDCCICS.C
- EDCCMI.C
- EDCCPL.C
- EDCCRHP.C
- EDCCSIG.C
- EDCCWIN.C
- EDCCZST.C
- EDCDATM.C
- EDCDAYS.C
- EDCDCOD.C
- EDCDIVX.C
- EDCDIVZ.C
- EDCDSHP.C
- EDCDT1.C
- EDCDT2.C
- EDCDT3.C
- EDCDT4.C

```

Line 40      Column 81      Insert
--*A-1-B-+-+---2-+-+---3-+-+---4-+-+---5-+-+---6-+-+---7-+-+---8
02 Condition-Token-Value.          00027000
COPY CEEIGZCT.                    00028000
03 Case-1-Condition-ID.            00029000
   04 Severity PIC S9(4) BINARY.    00030000
   04 Msg-No   PIC S9(4) BINARY.    00031000
03 Case-2-Condition-ID            00032000
   REDEFINES Case-1-Condition-ID.   00033000
   04 Class-Code PIC S9(4) BINARY.   00034000
   04 Cause-Code PIC S9(4) BINARY.   00035000
03 Case-Sev-Ctl PIC X.              00036000
03 Facility-ID  PIC XXX.            00037000
02 I-S-Info     PIC S9(9) BINARY.    00038000
                                     00039000
PROCEDURE DIVISION.                00040000
                                     00041000
PARA--MTHSLOG.                      00042000
                                     00043000
MOVE 5.65 TO ARG1RS.                00044000
CALL 'CEESSLOG' USING ARG1RS, FC, RESLTRS. 00045000
*****                                00046000
    
```

Remote Error List Problems Tasks

Filter matched 3 of 3 messages

ID	Message	Se...	Line	Location	Host Name	Date
IGYPS2106	IGYPS2106-S "DIVI" was found in the "VALUE" stat...	2	40	/DEMOVSE/IGZTMATH...	Local	Jan 26, 2007 4:39:27 PM
IGYOS4027	THE SYSTEM OPTION "SYM" IS INTERPRETED AS "...	0	-1	IGZTMATH.C	DEMOVSE	Jan 26, 2007 4:41:09 PM
IGYPS2106	"DIVI" WAS FOUND IN THE "VALUE" STATEMENT. ...	2	40	IGZTMATH.C	DEMOVSE	Jan 26, 2007 4:41:09 PM

z/OS LPEX Editor is active

start | Command Prompt | Plug-in Development ... | VSE - IGZTMATH.cbl - | untitled - Paint

Address | Go | DE | 98% | 4:44 PM Friday 1/26/2007

(2) Cross Plattform Solution development Approach with VisualAge Generator

* **New:** VisualAge Generator EGL Plug-in for VSE *

Rational Application Developer (RAD)

z/VSE Server

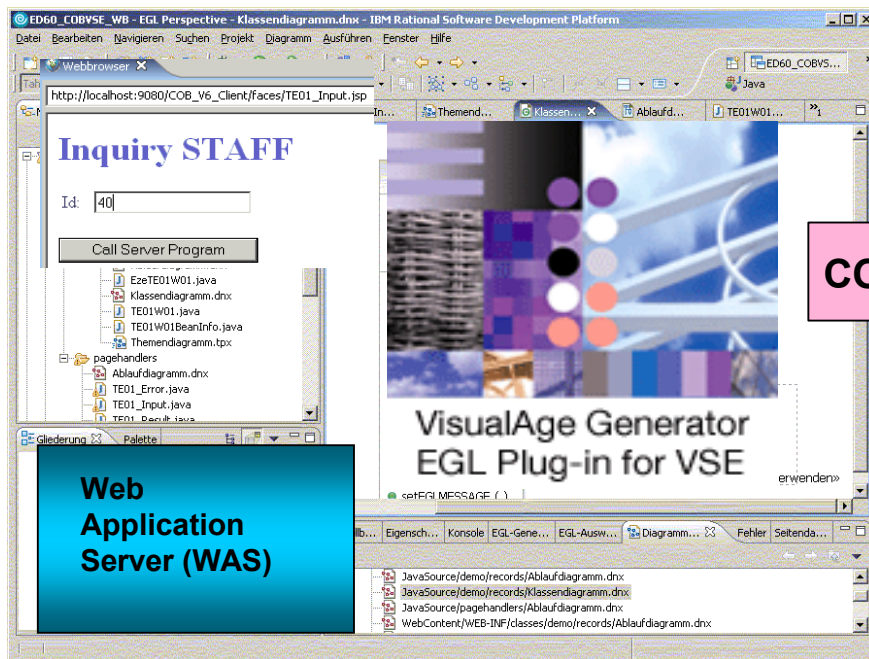

„Generate“

COBOL/CICS/batch

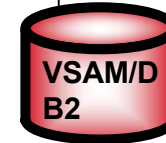
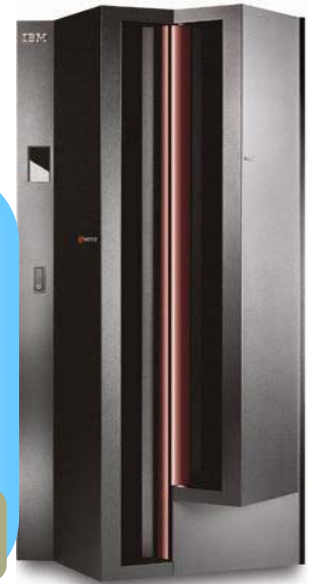
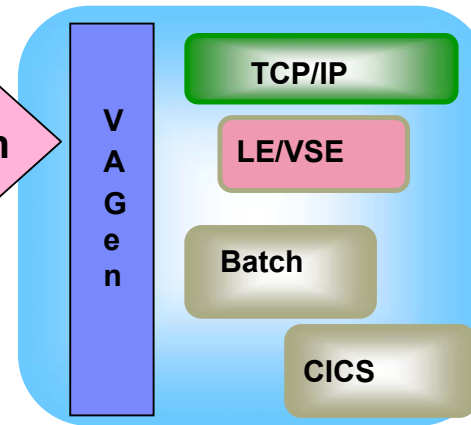

- Enterprise Generation Language (EGL)
- Java™ 2 Platform, Enterprise Edition (J2EE) connection Architecture (J2C/JCA)
- Java Server Pages (JSP), dynamic result page known by the Web Application Server (WAS)

Modernization / Growth Scenarios with VSE and Linux

Combine the scenarios, make use of synchronicity offerings from IBM and Novell.

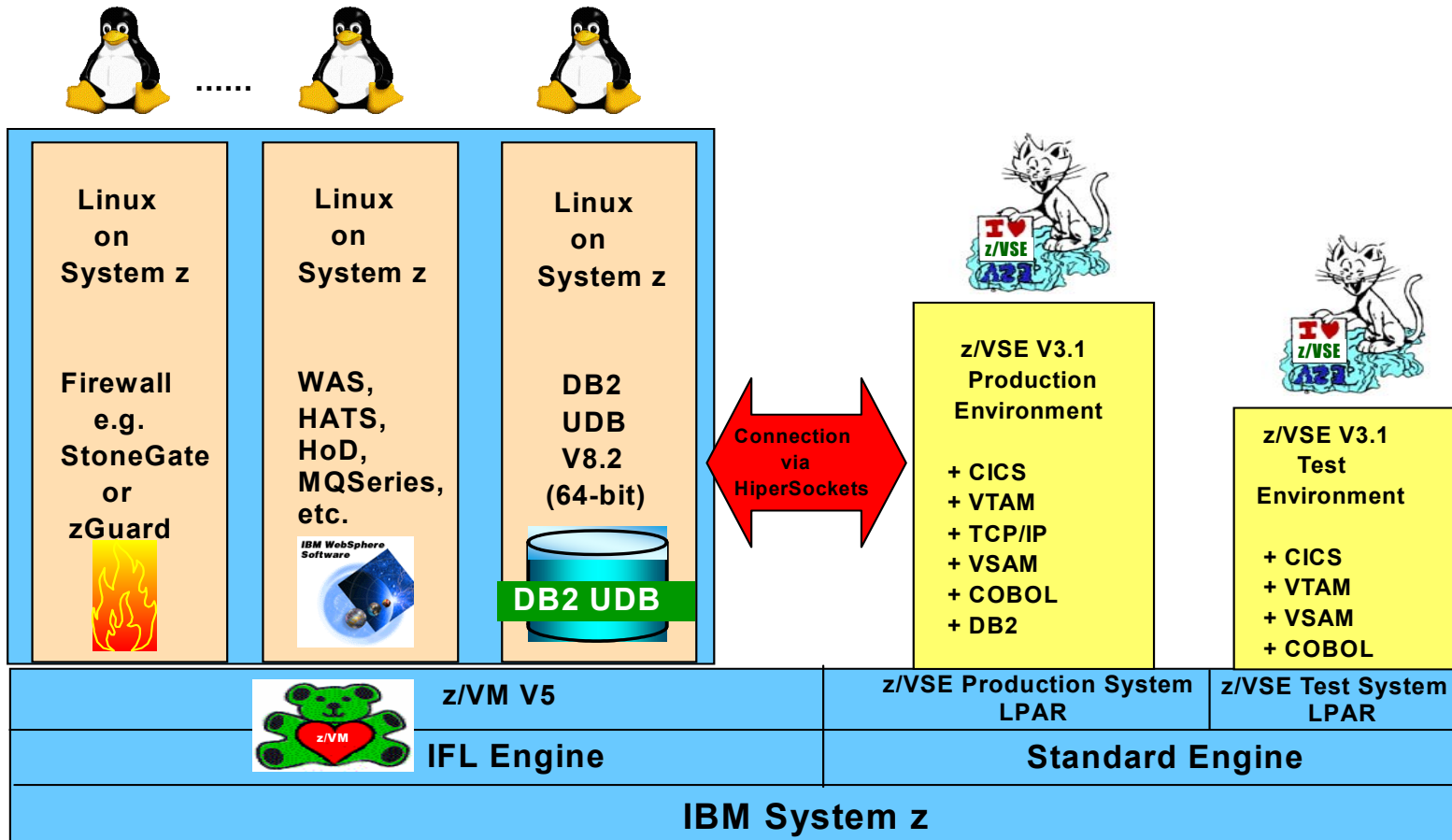

Visit the z/VSE Web Site

z/VSE Solutions



The screenshot shows the IBM z/VSE website interface. The address bar displays `http://www.ibm.com/servers/eserver/zseries/zvse/`. The navigation menu on the left includes links for Home, Products, Services & solutions, Support & downloads, and My account. The 'Solutions' link is circled in blue. The main content area features a 'z/VSE' header, a description of the product, and a 'Learn more' section with links to 'About VSE', 'News', and 'History of VSE'. A large banner announces 'Announcing z/VSE V3.1' with a '40 YEARS' logo. Below this, a 'Redesigned z/VSE homepage' section explains the site's redesign. A 'z/VSE Version3 Release 1' section lists supported hardware and software configurations. The right sidebar contains sections for 'We're here to help', 'Mark your calendar' (with events like 'Guide Share Europe' and 'WAVV conference'), 'Spotlights', and 'Middleware'.

👉 New Web presence: ibm.com/servers/eserver/zseries/zvse/solutions

Tools available in the VSE download area

- z/VSE/ESA Home Page – downloads for **FREE**
<http://www.ibm.com/servers/eserver/zseries/zvse/downloads>

- System management:
 - VSE CPU Monitoring tool
 - VSE Installed Software Report tool
 - TCP/IP Configuration
 - IP Trace tool
 - Keyman/VSE (SSL)
 - VSE Health Checker
 - Multi Instant Logic analyser for VSAM
 - JCalc, JLink, JRun (/LE VSE)

- Connector tools
 - *VSE Connector Client*
 - *VSE Navigator*
 - *VSE Maptool*
 - *VSEPrint*
 - *CICS2WS (SOA, WebServices)*

- *Connector Components*
 - *VSE Connector Client*
 - *VSE Redirector server*
 - *VSE Virtual Tape server*
 - *VSE Script server*

We appreciate your comments at : zvse@de.ibm.com

z/VSE internal and Customer events planned

- Announcement Event (german - Stuttgart) february 15

- Live Virtual Classes (LVC)
 - z/VSE Announcement Overview february 1
 - z/VSE 4.1 – new Pricing february 22
 - z/VSE – Solutions march 15

- GSE Spring (german –Berlin) march 26-28

- System z Tech Conf (Munich) april 16-20

- WAVV (Green Bay, WS) may 18-22

- System z Tech Conf (Austin,Texas) september 17-21

- GSE Fall (international – www.gsenet.de)

We appreciate your comments at : zvse@de.ibm.com

Additional Information

- z/VSE Home Page
<http://www.ibm.com/servers/eserver/zseries/zvse/>
- z/VSE Solutions and Utilities
<http://www-1.ibm.com/servers/eserver/zseries/zvse/solutions/>



- e-business Solutions for VSE/ESA SG24-5662
- e-business Connectivity for VSE/ESA SG24-5950
- CICS Transaction Server for VSE/ESA
CICS Web Support *SG24-5997-00*
- ***WebSphere Handbook (Connectors to z/OS and VSE)*** ***SG24-7042***

z/VSE Contact : zvse@de.ibm.com