



# Session E11

## z/VSE Trends and Directions

G. M. (Jerry) Johnston

**IBM**  
**SYSTEM z9 AND zSERIES EXPO**  
**October 9 - 13, 2006**

Orlando, FL

# Trademarks

The following are trademarks of the International Business Machines Corporation in the United States and / or other countries.

CICS\*

DB2\*

DB2 Connect

DB2 Universal Database

e-business logo\*

Enterprise Storage Server

HiperSockets

IBM\*

IBM logo\*

IBM System z

IMS

Multiprise\*

MQSeries\*

S/390\*

VSE/ESA

VTAM\*

WebSphere\*

iSeries

pSeries

xSeries

zSeries

z/Architecture

z/OS

z/VM

z/VSE

\* Registered trademarks of IBM Corporation

The following are trademarks or registered trademarks of other companies.

LINUX is a registered trademark of Linus Torvalds

Java and all Java-related trademarks and logos are trademarks of Sun Microsystems, Inc., in the United States and other countries

UNIX is a registered trademark of The Open Group in the United States and other countries.

Microsoft, Windows and Windows XP are registered trademarks of Microsoft Corporation.

SET and Secure Electronic Transaction are trademarks owned by SET Secure Electronic Transaction LLC.

Intel is a registered trademark of Intel Corporation.

## Abstract

This session includes a brief overview of recent VSE and VSE-related landmarks, the status of z/VSE V3, and a summary of the recent z/VSE V4 Preview. It will review IBM's strategy for z/VSE as well as discuss possible future directions for z/VSE.

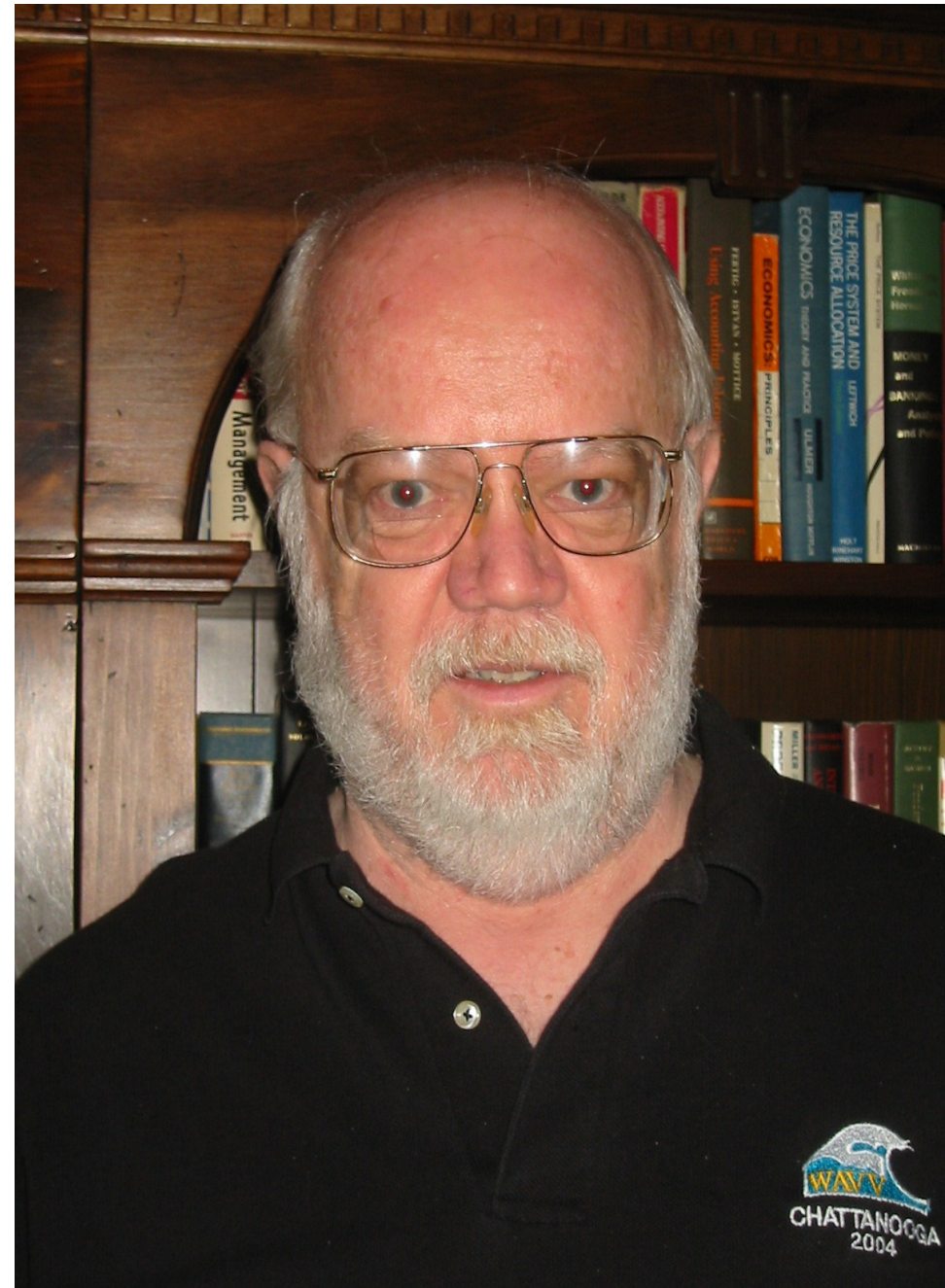

# **News - Recent Changes**

# IBM Mainframe & VSE Evolution

## ■ S/360 Model 30

- 30 KIPS (.03 MIPS)
- 16 – 64 KB

## ■ DOS/360

- 1 batch partition
- basic, but lovable

## ■ S/370->4300->9370->ES9000->S/390

## ■ DOS/VS->DOS/VSE->(SSX)->VSE/SP VSE/ESA V1->VSE/ESA V2

## ■ System z9 BC

- ~26-480 MIPS (1-way)
- 8 – 64 GB

## ■ z/VSE V3.1

- Batch and OLTP
- Interoperability

## ■ z/VSE V4.1 Preview

- still lovable

1960s



1970s



1980s



1990s



2000s

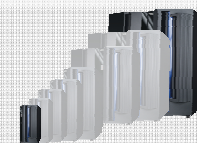

# Recent VSE History

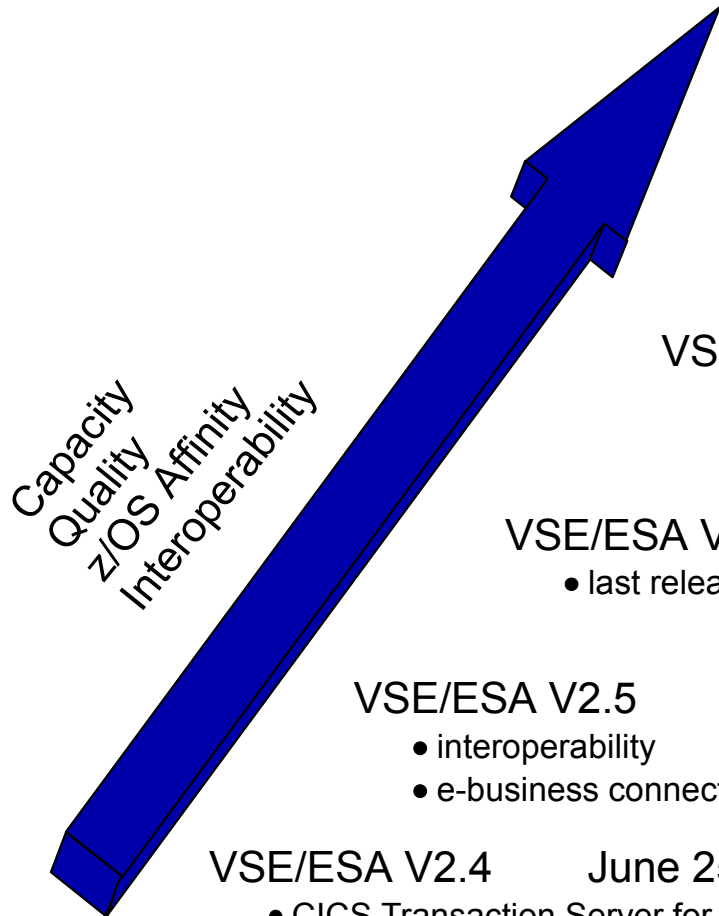

## **z/VSE V4 - Preview**

- z/Architecture only
- 64-bit real addressing
- SOD for sub-cap pricing



**z/VSE V3.1**      *March 4, 2005*

- zSeries features, FCP/SCSI
- 31-bit mode only

**VSE/ESA V2.7**      *March 14, 2003*

- enhanced interoperability
- ALS2 servers only



**VSE/ESA V2.6**      *Dec 14, 2001*

- last release to support pre-G5 servers

**VSE/ESA V2.5**      *Sept 29, 2000*

- interoperability
- e-business connectors

**VSE/ESA V2.4**      *June 25, 1999*

- CICS Transaction Server for VSE/ESA
- e-business



# Changes since mid-2005



- 06/11/2005 - VisualAge Generator EGL Plug in
- 06/21/2005 - WebSphere MQ client for VSE (no charge)
- 07/27/2005 - announce IBM System z9 109 (including z/VSE monitor SOD)
- 08/02/2005 - announce EoS for VSE/ESA V2.7 (effective 2/28/2007)
- 10/06/2005 - CICS2WS tool (n/c – supports VSE SOA web services)
- 11/01/2005 - FCP-SCSI qualification for DS6000 and DS8000
- 11/25/2005 - z/VSE V3.1.1 (hardware, BSM, VSE/POWER, etc.) available
- 01/01/2006 - withdrawal of ESL charge option
- 01/15/2006 - S/390 SUF discontinued (replaced by ShopzSeries)
- 02/07/2006 - announce EoS for HLASM V1.4 (effective 4/7/2007)
- 02/13/2006 - 31-bit I/O buffers for z/VSE V3 available
- 03/31/2006 - EoS for VSE/ESA V2.6 effective
- **04/27/2006 - IBM System z9 Announcement and z/VSE V4.1 Preview**
- 07/21/2006 - z/VSE V3.1.2 (service update and consolidation) available
- **08/29/2006 - SOD for z/VSE support of TS1120 tape drive encrypting capability**

# **Review and Status**



# z/VSE V3.1 Overview



- Selected IBM System z features
    - SCSI/FCP attached disk
    - Crypto Express2 including accelerator mode
    - CPACF
    - Basic Security Manager (BSM) and POWER enhancements
    - 31-bit VTAM I/O buffers
    - N\_Port ID Virtualization (for SCSI/FCP)
  - Further exploitation of IBM TotalStorage ESS, DS6000, DS8000, VTS
    - SCSI/FCP qualification for ESS
    - SCSI/FCP qualification for DS6000 and DS8000
  - Additional selected IBM System z features (also in VSE/ESA V2.7)
    - FICON Express4 for additional bandwidth
    - OSA Express2 1000BASE-T Ethernet for additional connectivity options
    - Up to 60 LPARs for more flexibility
- (\*) z/VSE V3 can execute in 31-bit mode only. It does not implement z/Architecture, and specifically does not implement 64-bit mode capabilities. z/VSE V3 is designed to exploit selected features of IBM System z hardware.

# z/VSE

## ■ Current Product

- **z/VSE V3.1** (GA 3/2005)
- ESA/390 (31-bit) mode only
  - up to 2GB real processor storage
- supports
  - System z9 EC *and* z9 BC
  - eServer zSeries 990, 890, 900, 800
  - Multiprise 3000 & S/390 G5/G6**
- HiperSockets
- CPACF
- Crypto Express2 (configurable)
- FCP/SCSI disks & NPIV
  - DS8000, DS6000, ESS
- FICON Express2 & 4
- OSA Express2
- 31-bit buffers for ACF/VTAM
- **SOD for TS1120 encrypting tape**

## ■ Future Product

- **z/VSE V4.1** (Preview 4/2006)
- **z/Architecture (64-bit) mode only**
  - up to 8GB real processor storage**
- supports
  - System z9 EC *and* z9 BC
  - eServer zSeries 990, 890, 900, 800
- **New subcapacity pricing option (z9 only)**
- HiperSockets
- CPACF + **enhancements**
- Crypto Express2 (configurable)
- FPC/SCSI disk & NPIV + **point-to-point**
  - DS8000, DS6000, ESS
- FICON Express2 & 4
- OSA Express2
- 31-bit buffers for ACF/VTAM
- **SOD for TS1120 encrypting tape**

## z/VSE Server Support

IBM Servers	z/VSE V4.1 Preview (GA tbd)	z/VSE V3.1	VSE/ESA V2.7
IBM System z9 Enterprise Class (formerly z9-109)	Yes	Yes	Yes
<b>IBM System z9 Business Class</b>	Yes	Yes	Yes
zSeries 990, 890, 900, 800	Yes	Yes	Yes
S/390® Parallel Enterprise Server™ G5/G6	No	Yes	Yes
S/390® Multiprise® 3000	No	Yes	Yes
S/390® Parallel Enterprise Server™ G1/2/3/4	No	No	No
S/390® Multiprise® 2000	No	No	No
S/390® Integrated Server	No	No	No
P/390 and R/390	No	No	No
ES/9000 – 9221, 9121, 9021	No	No	No

# System z Exploitation

Functions	z/VSE V4.1 (Preview)	z/VSE V3.1 (Note 1)	VSE/ESA V2.7
z/Architecture mode only	Yes	No	No
64-bit <i>real</i> addressing (up to 8 GB proc storage)	Yes	No	No
Fibre Channel Protocol (FCP) for SCSI Disks	Yes	Yes	No
CP Assist for Cryptographic Function (CPACF)	Yes	Yes	No
Crypto Express2 ('PCICA' SSL encryption assist)	Yes	Yes	Yes
HiperSockets™ (including spanned HiperSockets)	Yes	Yes	Yes
FICON Express2™ & FICON Express4™	Yes	Yes	Yes
OSA Express2 (incl 10Gb and Gb ethernet)	Yes	Yes	Yes
OSA Integrated Console Controller (OSA-ICC)	Yes	Yes	Yes
Up to 60 LPARs	Yes	Yes	Yes
Up to 4 LCSSs	Yes	Yes	Yes

Note 1: z/VSE V3 can operate in 31-bit mode only. It does not implement z/Architecture and specifically does not implement 64-bit mode capabilities. z/VSE V3 is designed to support selected features of IBM System z hardware.

# IBM System z Storage Options



IBM TotalStorage	DS6000	ESS 750, 800, 800Turbo	DS8000
ESCON	Not Avail	Yes	Yes
FICON	Yes	Yes	Yes
FCP/SCSI	Yes	Yes	Yes

# Release Status

VSE Version and Release	Marketed	Supported	End of Support
z/VSE V4.1 (Preview – not yet avail)	tbd	tbd	tbd
<b>z/VSE V3.1</b>	<b>Yes</b>	<b>Yes</b>	<b>tbd</b>
VSE/ESA V2.7	No	Yes	02/2007
VSE/ESA V2.6	No	No	03/2006

# **NEW: IBM TS1120 Tape Drive Encryption**



# the industry's first comprehensive end to end tape encryption solution

- First encrypting tape drive - IBM System Storage TS1100 tape drive family
  - Standard feature on all TS1120 Tape Drives
  - Chargeable upgrade feature for existing TS1120 Tape Drives
- A new, innovative IBM Encryption Key Manager component for the Java platform™ component supported on a wide range of systems including:
  - z/OS, i5/OS, AIX, HP, Sun, Linux (incl System z), and Windows
- Integration with IBM tape systems, libraries
- Enhancements to Tivoli Storage Manager to exploit TS1120 encryption
- Integration with System z encryption key, policy management, security and cryptographic capabilities. Complements existing System z Encryption Facility for z/OS program product
- New services and consulting for tape data encryption and key management



**TS1120**  
500 GB  
100 MB/sec

**Encryption Key  
Manager**





# IBM System Storage TS1120 Tape Drive Encryption - Highlights

- Encryption a standard feature (FC 9592) on all TS1120 Tape Drives shipped on (or after) September 8, 2006
  - New hardware supports data encryption using 256 bit AES encryption
  - Microcode enhancements supporting encryption policy and key communications
  - Encryption performed with minimal (less than 1% data rate performance impact)
  - Data is compressed and encrypted – no change in media usage due to encryption
  - Supports “traditional” and “encrypted” modes of operation
  - Encryption “disabled” unless otherwise specified
- A chargeable upgrade feature (FC 5592) to add encryption to existing TS1120 Tape Drives is also available on September 8, 2006
  - A “Returned Parts” upgrade – IBM gets the used parts back
  - The upgrade may contain refurbished parts
- List price increase on date of announcement
  - Slightly more than 10%



# TS1120 Drive-based Encryption

**SOD\*:** *“z/VSE V3.1 support of the TS1120 Tape Drive with encryption is planned for first half 2007. It is also IBM's intent to support z/VSE V4.1 (when made available) using Systems Managed Encryption with the TS1120. z/VSE support will require the Encryption Key Manager component running on another operating system other than z/VSE using an out-of-band connection.”*

## Centralized key management

- Help protect and manage encryption keys
  - Highly secure and available key data store
  - Long term key management
  - Disaster recovery capabilities
- Single point of control
  - Non-VSE, Java-based platform
  - TCP/IP connection to tape control unit



- Highly secure
- High performance archive encryption
- Transparent to existing processes and applications
- Can help provide audit compliance

\* All statements regarding IBM's future direction and intent are subject to change or withdrawal without notice, and represent goals and objectives only.

# z/VSE V4 Preview

Note: Previews reflect current plans. Information provided here is for planning purposes only. All statements regarding IBM's plans, directions, and intent are subject to change or withdrawal without notice. Any decisions taken based on the information provided here is at the customer's risk.



# z/VSE V4: Preview - April 2006

- **z/Architecture mode only**
  - runs on IBM System z9 EC and z9 BC, plus IBM eServer z990, z890, z900, z800
- **64-bit real addressing (up to 8 GB processor storage)**
  - transparent to user applications
  - not designed for 64-bit *virtual* addressing or 64-bit mode for *user* applications
- **Easy upgradeability**
  - Fast Service Upgrade (FSU) from z/VSE V3.1 and VSE/ESA V2.7
  - minimum required VM level is z/VM V5.2 (if running z/VSE V4 under z/VM)
- **LPAR-based sub capacity monitoring tool**
  - fulfills Statement of Direction July 2005 IBM Systems z9 announcement
- **Statement of Direction on z/VSE V4 software pricing**
  - better granularity with new sub-capacity pricing option
  - on selected processors according to applicable terms and conditions
  - similar to existing z/OS sub-capacity



# Statement of Direction for z/VSE V4

It is IBM's intent to provide new software pricing for z/VSE V4 when running on select processors, subject to applicable terms and conditions. IBM expects this new software pricing metric to provide more granularity and a subcapacity pricing option

System z9 @ 100 MSUs

60 MSUs	20 MSUs
DB2	SDF II*
MQSeries	COBOL
CICS	z/VSE V4
VTAM	z/VSE V4
z/VSE V4	

## Full-Capacity Pricing Metrics:

Based on total rated capacity (i.e. 100 MSUs) of the MACHINE where product executes.

Ex: zELC, TWLC

## Sub-Capacity Pricing Metrics:

Based on actual (peak 4 hour rolling average) monthly utilization of the LPAR(s) where a product executes (3 MSU minimum).

Products used for purposes of illustration only. They may, or may not, be available with subcapacity pricing. All statements regarding IBM's plans, directions, and intent are subject to change or withdrawal without notice.

# Rolling 4-Hour Average

Capture the 4-hour rolling average of utilization for each interval in the month

## 4-Hour Rolling Average

11 am (8,9,10,11): 35 MSUs  
12 pm (9,10,11,12): 55 MSUs  
1 pm (10,11,12,1): 65 MSUs  
2 pm (11,12,1,2): 75 MSUs  
3 pm (12, 1, 2, 3): 80 MSUs  
4 pm (1, 2, 3, 4): 65 MSUs

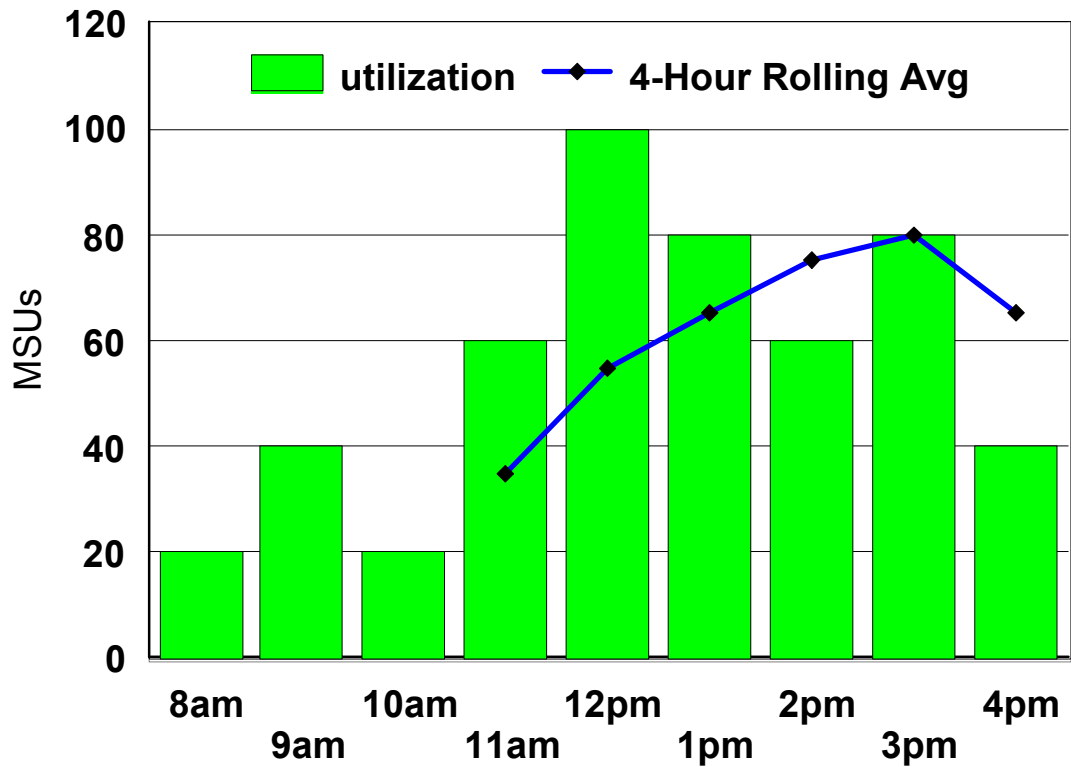

# Example: Rolling 4-Hour Average

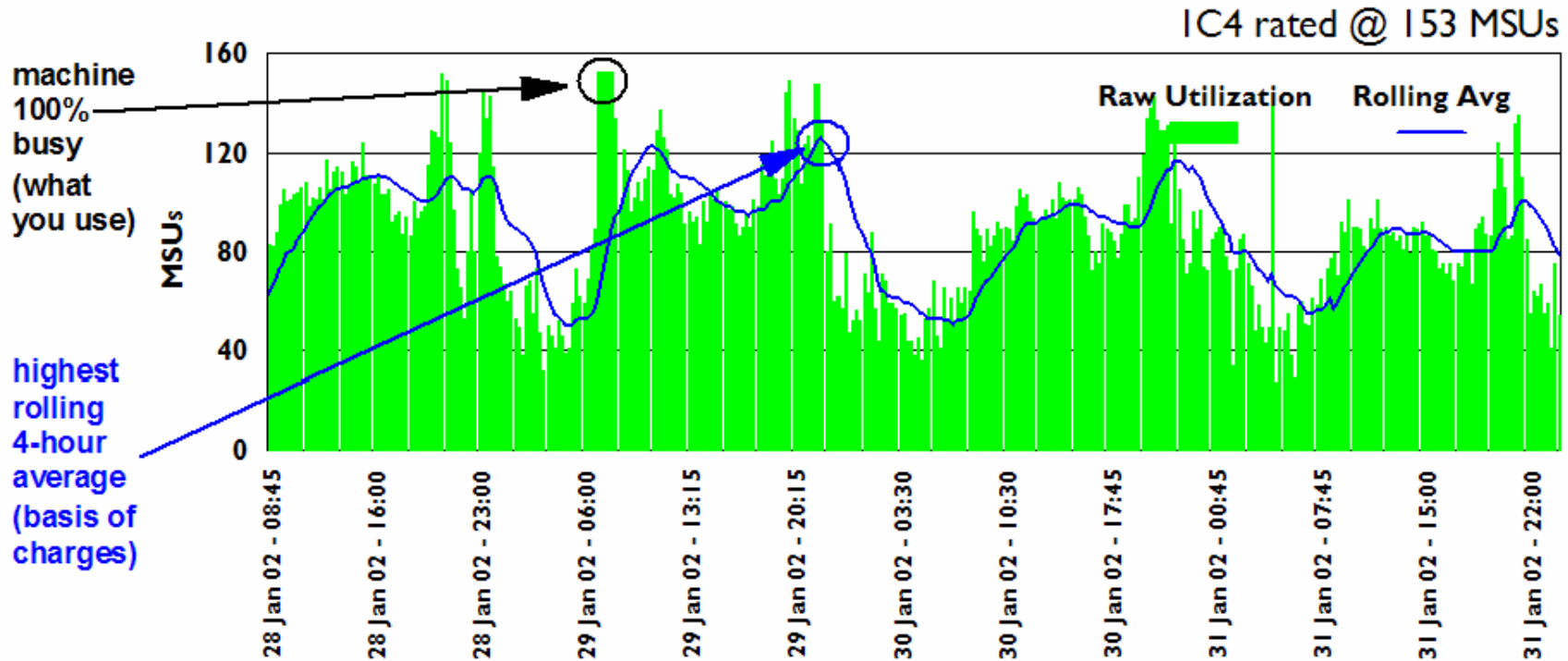

Rolling 4-Hour Average utilization smoothes out peaks in raw utilization. Allows for varied peaks & bases Software charges on more moderate measure.

# Example: z/OS Subcapacity Calculation

Product	EWLC Sub-Cap	EWLC Full-Cap	zELC 0A2
COBOL 5648A25	\$1129 20 MSUs	\$2459 44 MSUs	\$2286 zELC 0A2
Fortran 5668805	477 zELC 0A2	477 zELC 0A2	477 zELC 0A2
REXX 5695013	1335 zELC 0A2	1335 zELC 0A2	1335 zELC 0A2
CICS TS 5655147	7209 28 MSUs	12513 44 MSUs	11193 zELC 0A2
DB2 V7 5675DB2	6908 28 MSUs	11616 44 MSUs	11448 zELC 0A2
z/OS 5694A01	16735 43 MSUs	17060 44 MSUs	18935 zELC 0A2
Monthly TOTAL	\$33,793	\$45,460	\$45,674

Prices in US\$ as of March 2005

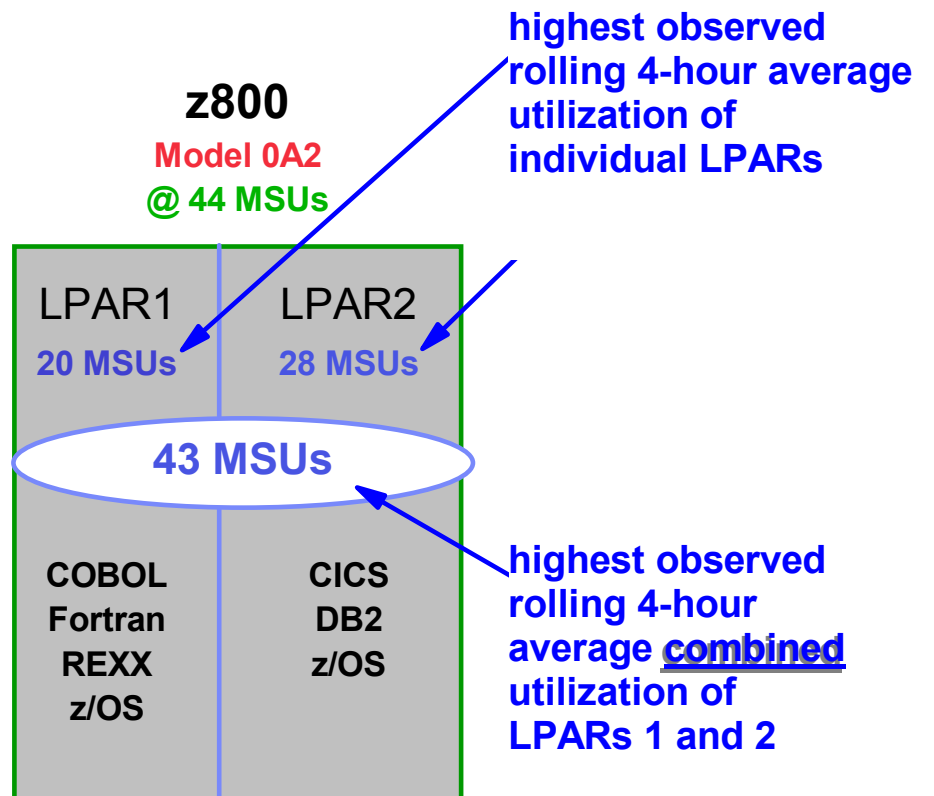



# Benefits of Sub Capacity Pricing

- Disconnect Hardware Growth from Software Charges for SubCap Products
  - Allows you to grow hardware capacity independently of software capacity  
e.g. upgrade server and pay for software based on the actual utilization of the server
  - Grow into hardware capacity gradually with a 1 MSU level of granularity
  - Spike into "spare" capacity without incurring permanent software charges
  - Manage utilization without having to turn engines on and off
- Grow an LPAR without affecting Software in other LPARs
  - Isolate products in specific LPARs to reduce software costs (optional)
  - Limit LPAR utilization to control software costs (optional)
  - Add capacity to production LPARs without impacting test and/or development LPARs
- Align Software Charges with Utilization
  - Pay based on highest rolling 4-hour average each month, not peak utilization
  - Sub Capacity Monitoring Tool manages measurement and reporting
  - Software charges increased/decreased monthly based on variations in utilization

# Sub Capacity Pricing Option with z/VSE V4

- Basic Requirements
  - z9 BC or z9 EC
  - z/VSE V4 (no older VSE version allowed on the processor, ie. no VSE/ESA V2, no z/VSE V3)
  - If running under VM: z/VM 5.2 is required
- Timing Requirements
  - Sub Cap Pricing begins with the submission of 1st full month report
  - Data collection period: 2nd of the previous month - 1st of the current month
  - Data submission period: 2nd - 9th following data collection

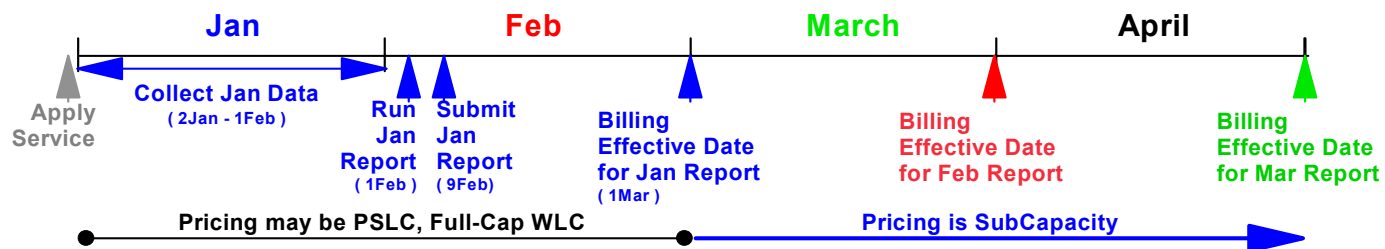

- Reporting Requirements
  - Must report ALL LPARs (production, test, development, etc.)
  - 95% data collection
  - Default (i.e. worst case) is full-capacity prices
  - 2 month full-capacity transition period



# Strategy

# z/VSE “PIE” Strategy

- Help **Protect** existing customer investments in core z/VSE programs, data, equipment, IT skills, *plus* business processes, end user training, etc.
  - modernize, i.e. extend z/VSE resources to Web
  - exploit IBM servers, storage, and software
  - z/OS affinity
- Help **Integrate** z/VSE with the rest of IT, based on open and industry standards
  - IBM middleware
  - z/VSE on demand connectors and SOA web services
- Help **Extend** solutions using Linux on System z
  - position Linux as preferred platform for new workloads
  - low cost, low risk, fast time-to-market
  - new line-of-business applications
  - low TCO and infrastructure simplification



# Customer Application Portfolio:

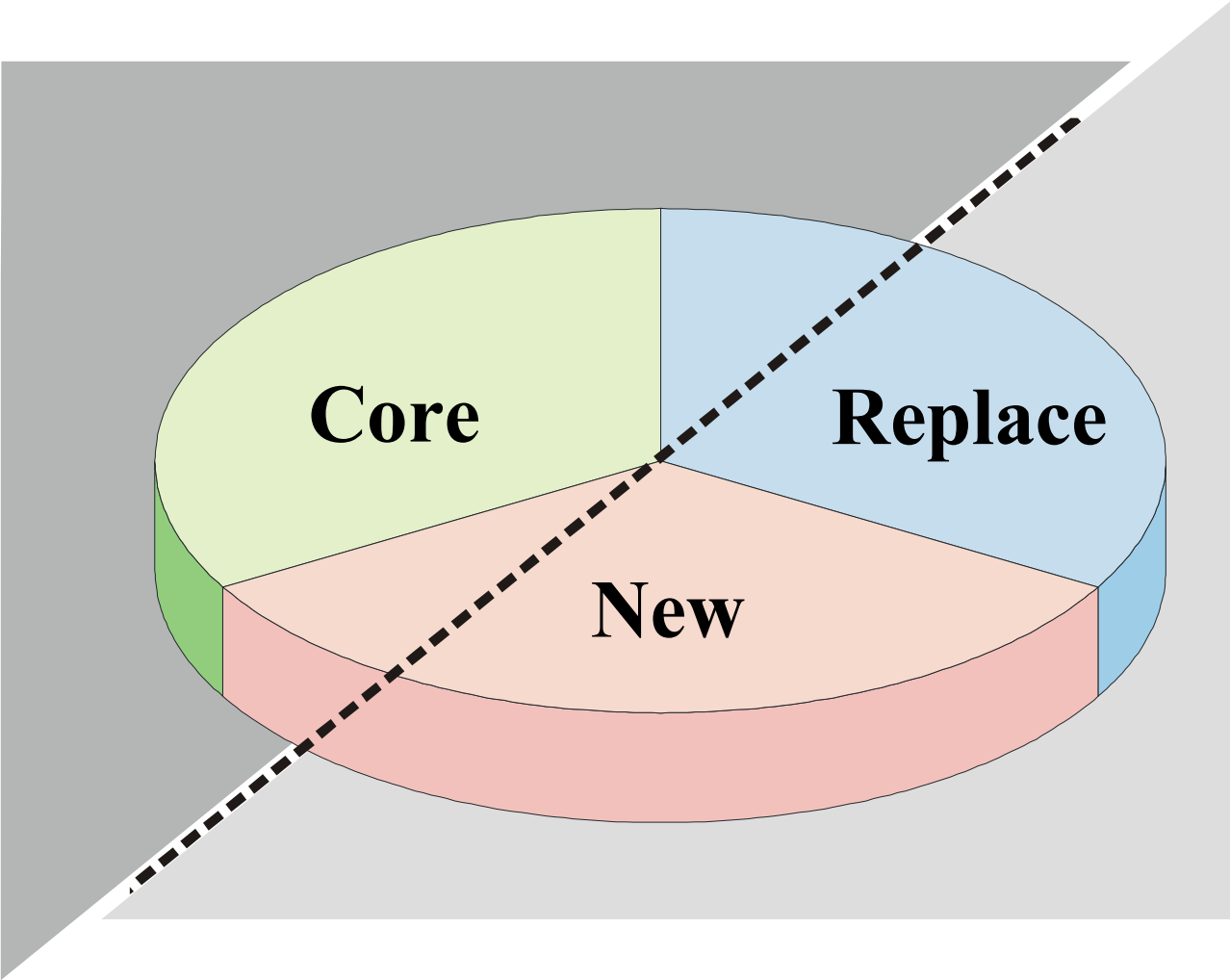

Note: Pie arbitrarily divided into thirds. Percent of applications in each category is unique to each customer

# Integrating z/VSE into the IT network

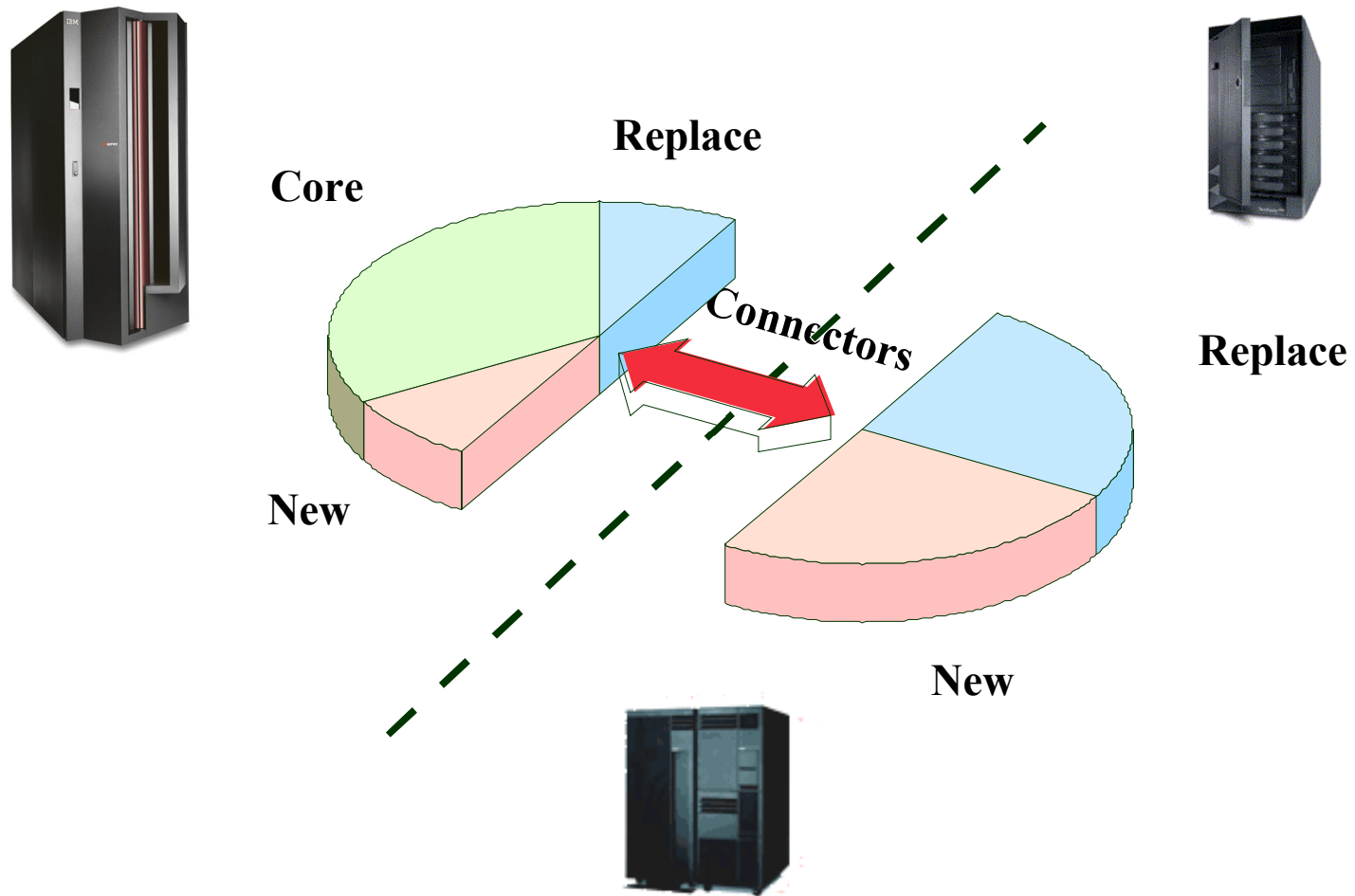

# Hybrid model

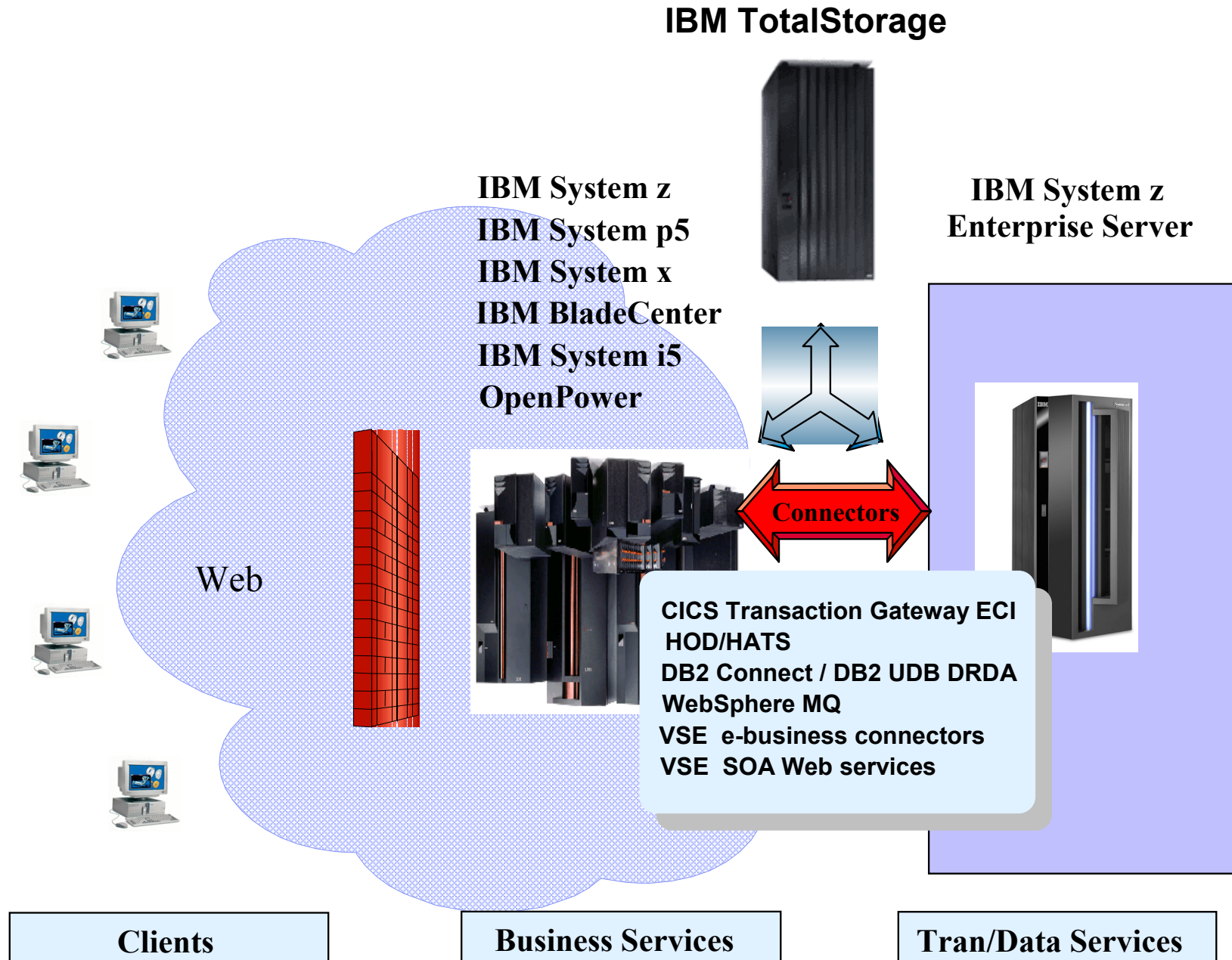

# z/VSE Interoperability

Information on Demand Functions	z/VSE V3.1	VSE/ESA V2.7
<b>VSE Connectors (no additional charge)</b>		
SOA Web Services, i.e. SOAP and XML	Yes	Yes
VSAM Redirector	Yes	Yes
VSAM, POWER, Librarian, ICCF lib, console	Yes	Yes
VSE Script and DL/1	Yes	Yes
DB2 Stored Procedures for VSAM and DL/1	Yes	Yes
<b>IBM Middleware (priced)</b>		
CICS Transaction Gateway ECI	Yes	Yes
Host on Demand / Host Application Transformation	Yes	Yes
DB2 Connect/DB2 UDB (DB2 Server for VSE PRPQ)	Yes	Yes
WebSphere MQ (VSE Client no charge)	Yes	Yes

Note 1: z/VSE V3 can operate in 31-bit mode only. It does not implement z/Architecture and specifically does not implement 64-bit mode capabilities. z/VSE V3 is designed to support selected features of IBM System z hardware



# **Linux and z/VSE**

# Limits of z/VSE Affinity with z/OS

**z/OS**

**z/OS Parallel Sysplex**  
Systems Mgmt, Capacity (incl 64-bit), Availability

IMS DC TSO	CICS Trans Server ACF/VTAM, TCP/IP LE COBOL, PL/1, C DFSORT, MQSeries DB2, IMS DB, VSAM	<i>Unix System Services</i> <i>heavy duty e-business</i> <i>ie. WebSphere Appl Server</i> <i>Enterprise JavaBeans</i> <i>DB2 UDB</i>
---------------	---	--

Unique to MVS

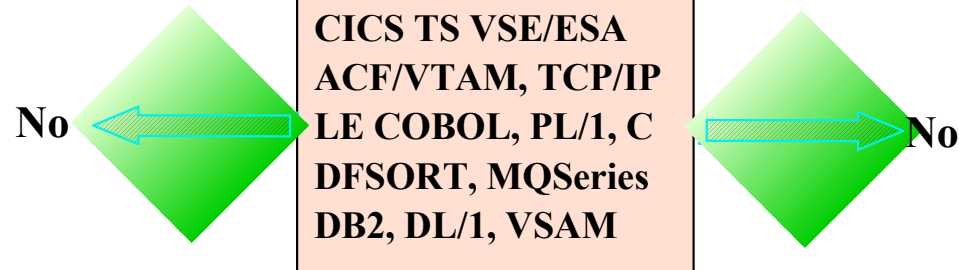

**z/VSE**

# The best of z/VSE and Linux on System z

## z/OS

**z/OS Parallel Sysplex**  
**Systems Mgmt, Capacity (incl 64-bit), Availability**

<b>IMS DC</b> <b>TSO</b>	<b>CICS Trans Server</b> <b>ACF/VTAM, TCP/IP</b> <b>LE COBOL, PL/1, C</b> <b>DFSORT, MQSeries</b> <b>DB2, IMS DB, VSAM</b>	<i>Unix System Services</i> <i>heavy duty e-business</i> <i>ie. WebSphere Appl Server</i> <i>Enterprise JavaBeans</i> <i>DB2 UDB</i>
-----------------------------	--	--

**Unique to MVS**

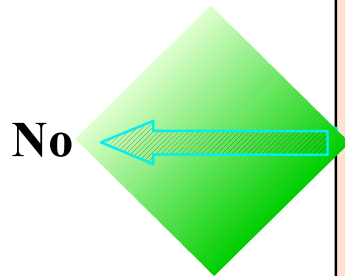

**CICS TS VSE/ESA**  
**ACF/VTAM, TCP/IP**  
**LE COBOL, PL/1, C**  
**DFSORT, MQSeries**  
**DB2, DL/1, VSAM**

**z/VSE**

*WebSphere Appl Server*  
*Enterprise JavaBeans*  
*DB2 UDB*

**Linux on System z**

# Think *inside* the box

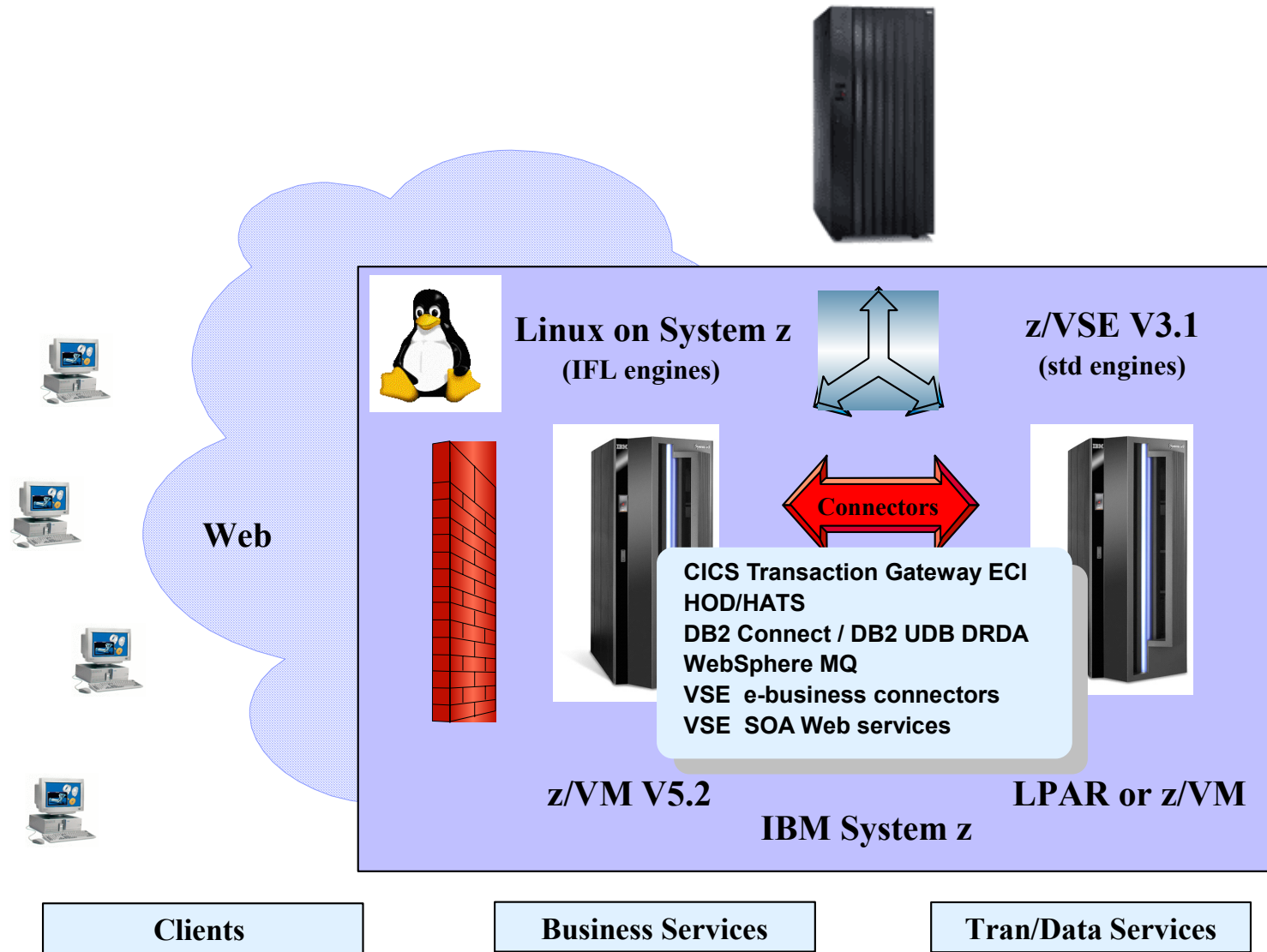

# Advantages for z/VSE Customers

- Linux applications based on IBM Middleware
  - WebSphere Application Server
  - DB2 UDB
  - Lotus® Domino™
  - Communications Server
  - Advanced application development tools
- Linux-based open source and/or ISV applications
  - Linux on System z exploits 64-bit capabilities
  - Complement 31-bit core VSE applications
- Integrate Linux and z/VSE solutions
  - Linux access to core z/VSE applications and data
  - z/VSE access to new Linux applications and data
- Infrastructure simplification to help reduce cost
  - Consolidate existing distributed servers
  - TCO benefits of Linux and System z

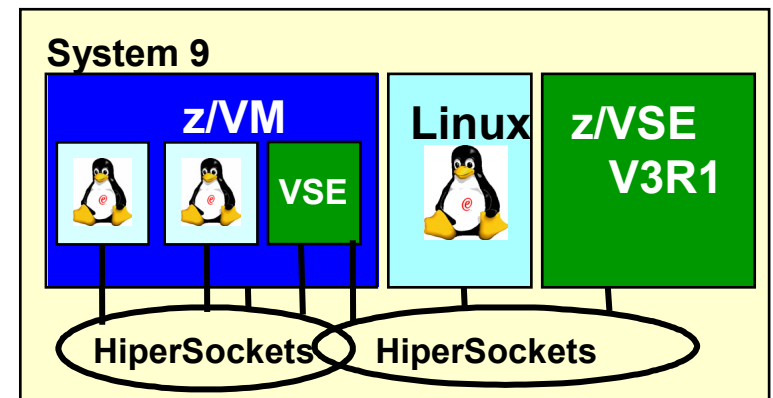
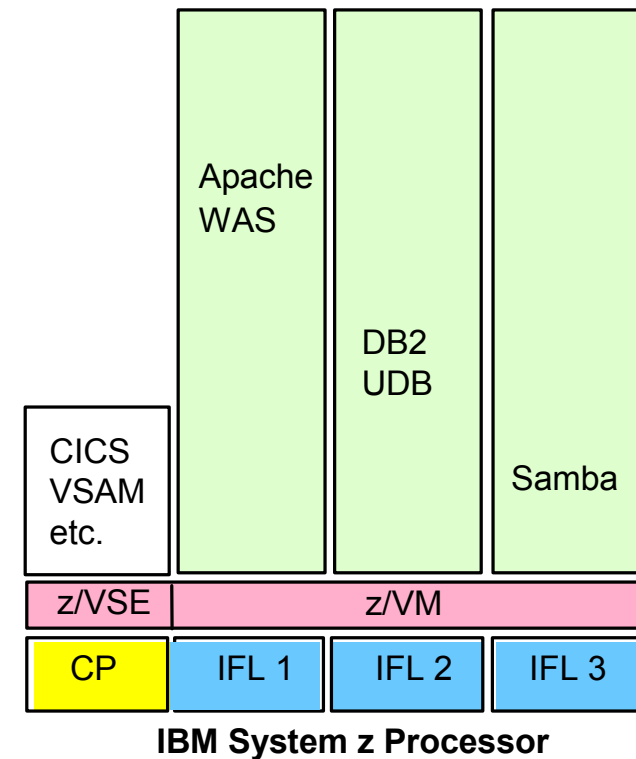

# VSAM Connector

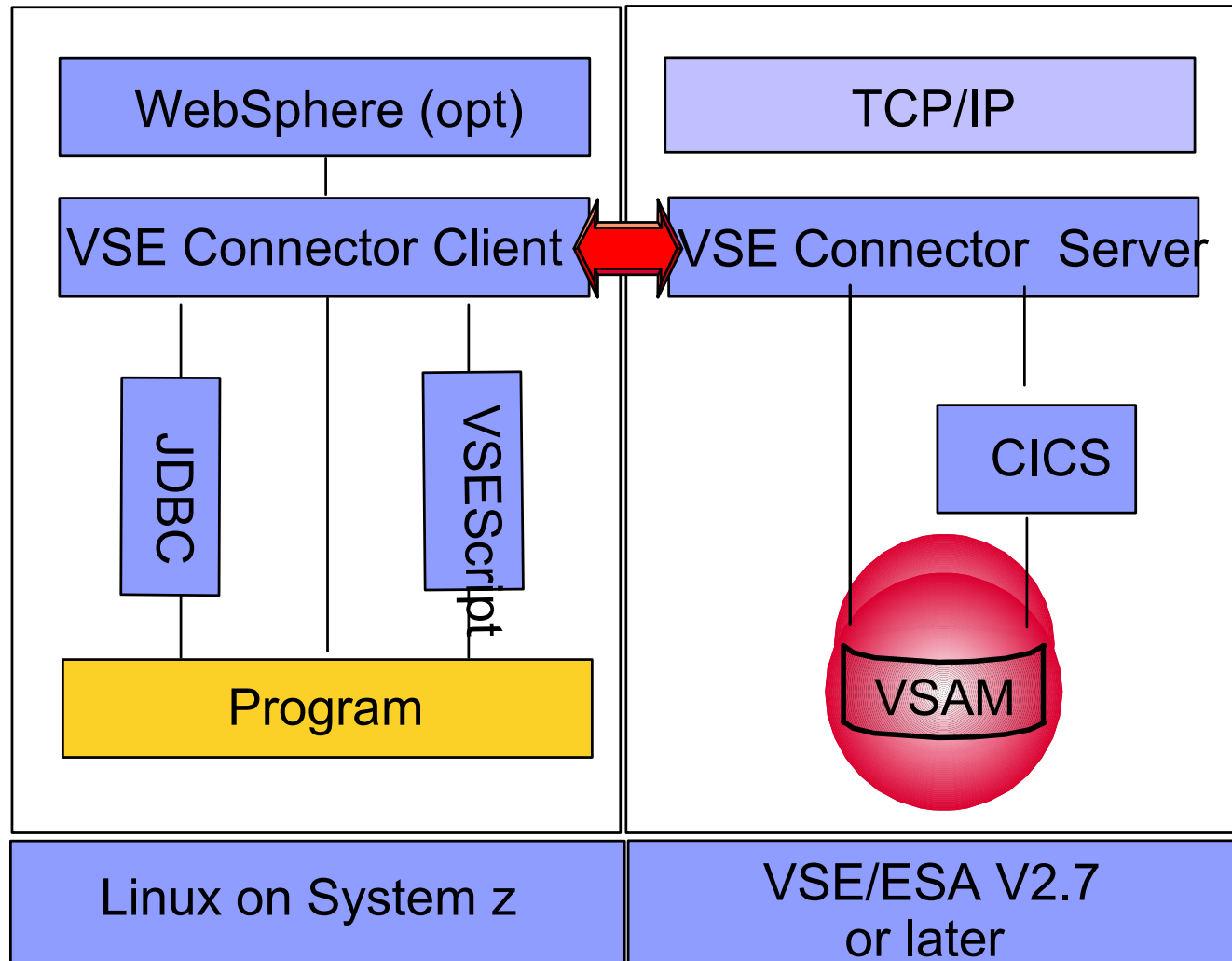

# VSE/VSAM Redirector

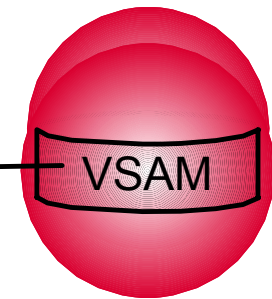
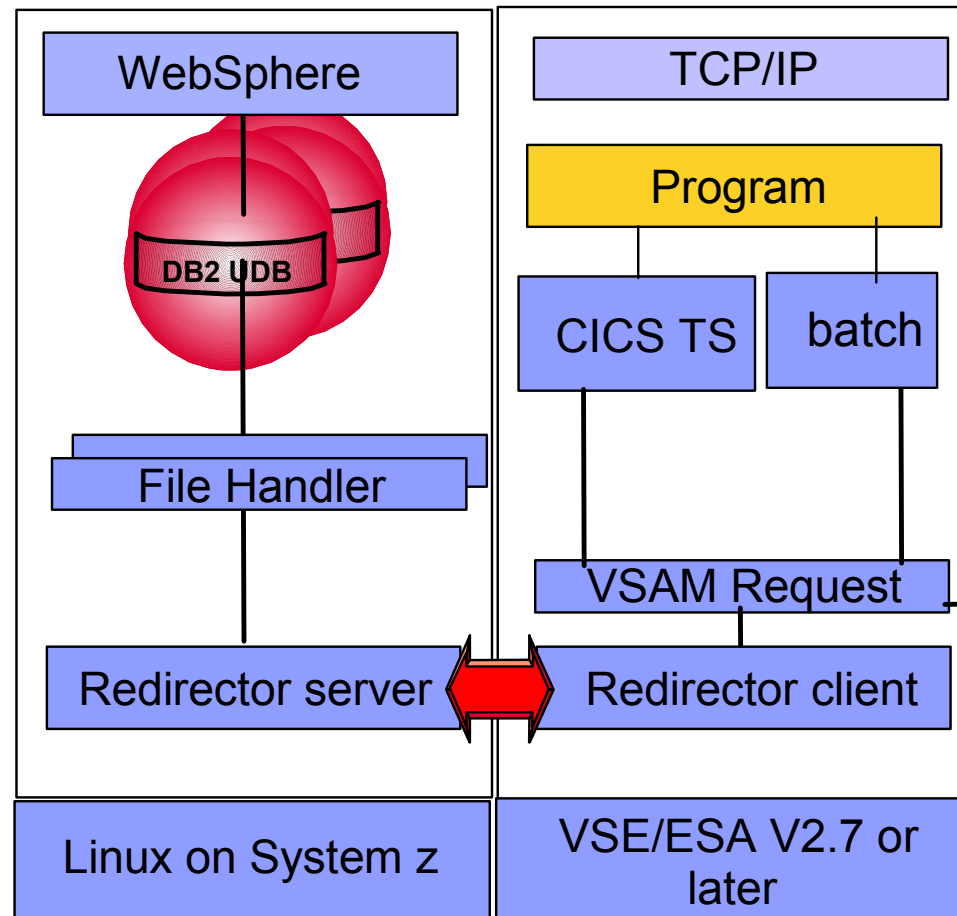

# z/VSE and Linux on System z

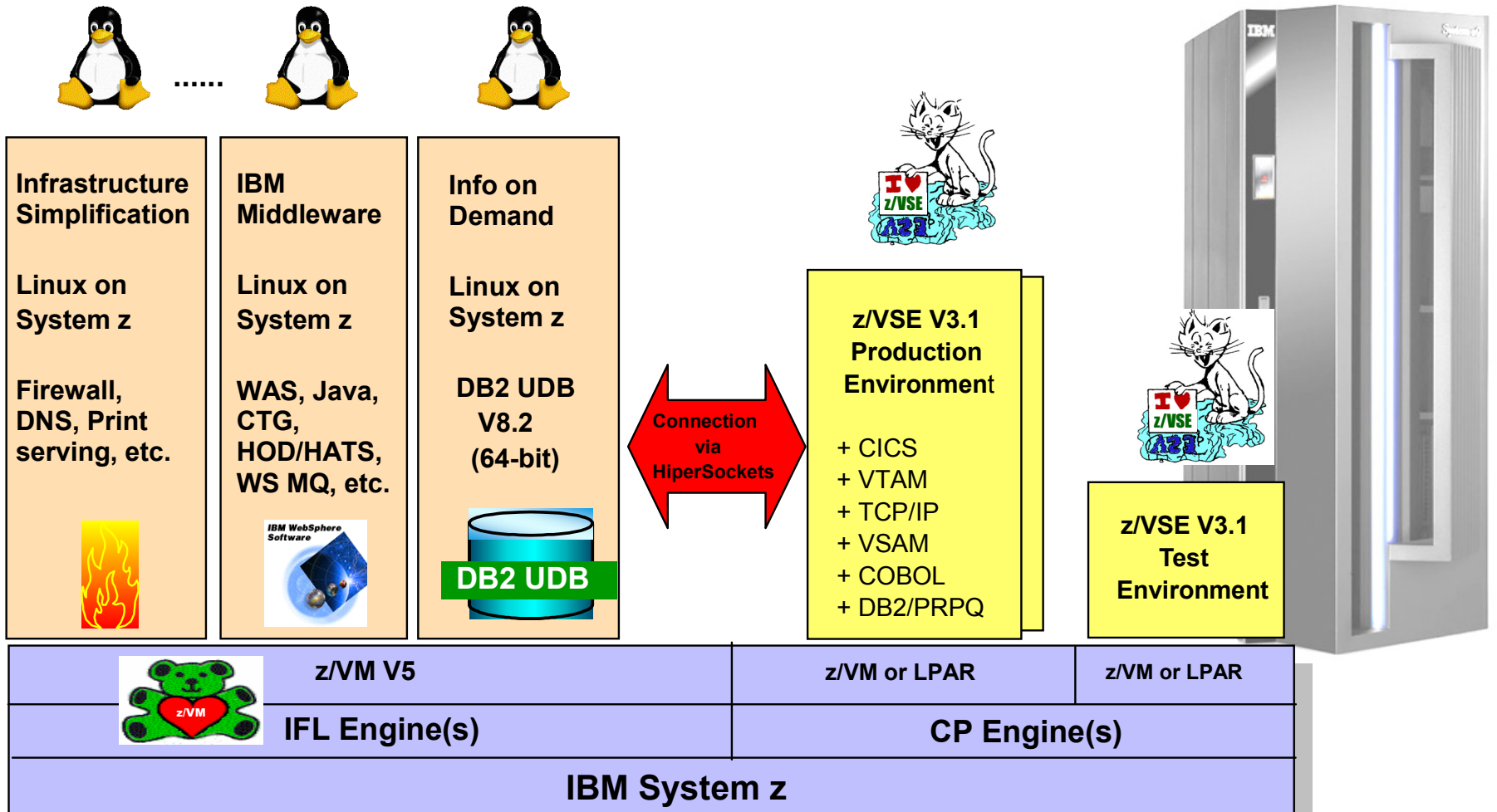



# Exploiting the System z Platform

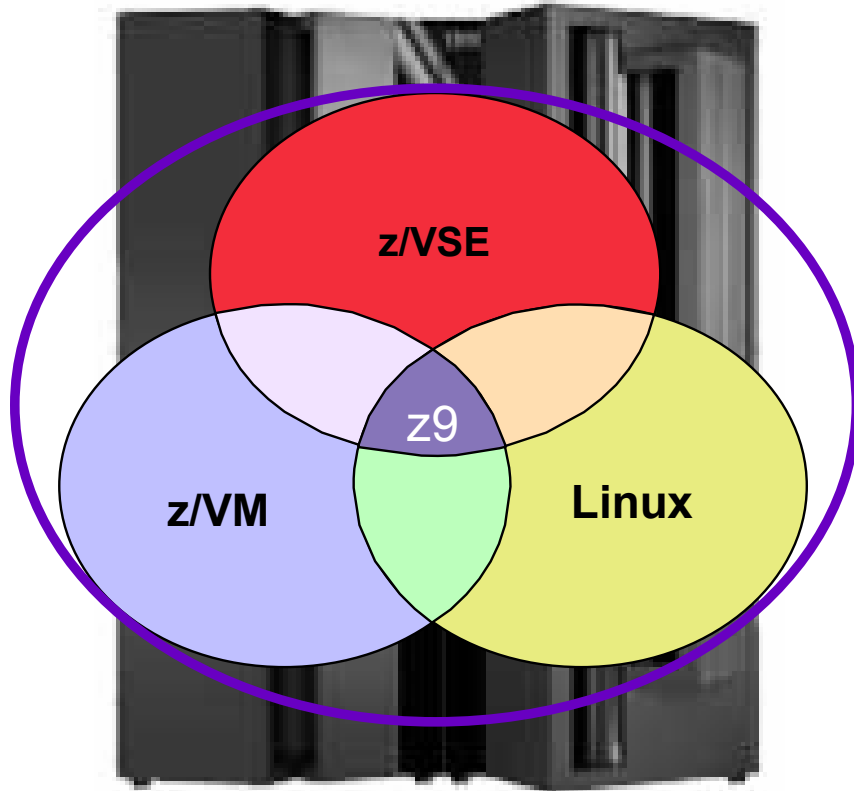

- z/VSE
  - Protect core IT investments
  - Robust, secure enterprise server
  - Cost-effective solutions
  - Interoperability with network/servers
  - z/OS affinity
- Linux on System z
  - Large portfolio of new applications
  - Platform for IBM middleware
  - Infrastructure Simplification
  - Massive scalability
- z/VM
  - Highly flexible, industrial strength
  - multiple VSE and Linux images
  - Designed to exploit System z

# z/VSE Directions

## ■ **Protect**

- basic hardware support and selective exploitation
  - IBM System z9
  - IBM TotalStorage (incl DS8000 Turbo, TS1120 & encryption, etc.)
- value
  - Availability / integrity / reliability / security
  - continuity / stability / z/OS affinity
  - ease-of-use / maintainability / serviceability
  - lower total cost of ownership (TCO) / flexible terms and conditions
  - specific customer requests (WAVV, GSE, individuals, etc. requirements)

## ■ **Integrate**

- connectivity based on open and industry standards
- network integration (including on demand VSE Connectors & SOA web services)

## ■ **Extend**

- integrate / exploit capabilities of Linux on IBM System z

# **Summary/Wrap-Up**

# z/VSE “PIE” Strategy

- Help **Protect** existing customer investments in core z/VSE programs, data, equipment, IT skills, *plus* business processes, end user training, etc.
  - modernize, i.e. extend z/VSE resources to Web
  - exploit IBM servers, storage, and software
  - z/OS affinity
- Help **Integrate** z/VSE with the rest of IT, based on open and industry standards
  - IBM middleware
  - on demand connectors and SOA web services
- Help **Extend** solutions using Linux on System z
  - position Linux as preferred platform for new workloads
  - low cost, low risk, fast time-to-market
  - new line-of-business applications
  - low TCO and infrastructure simplification



# z/VSE and Linux on System z

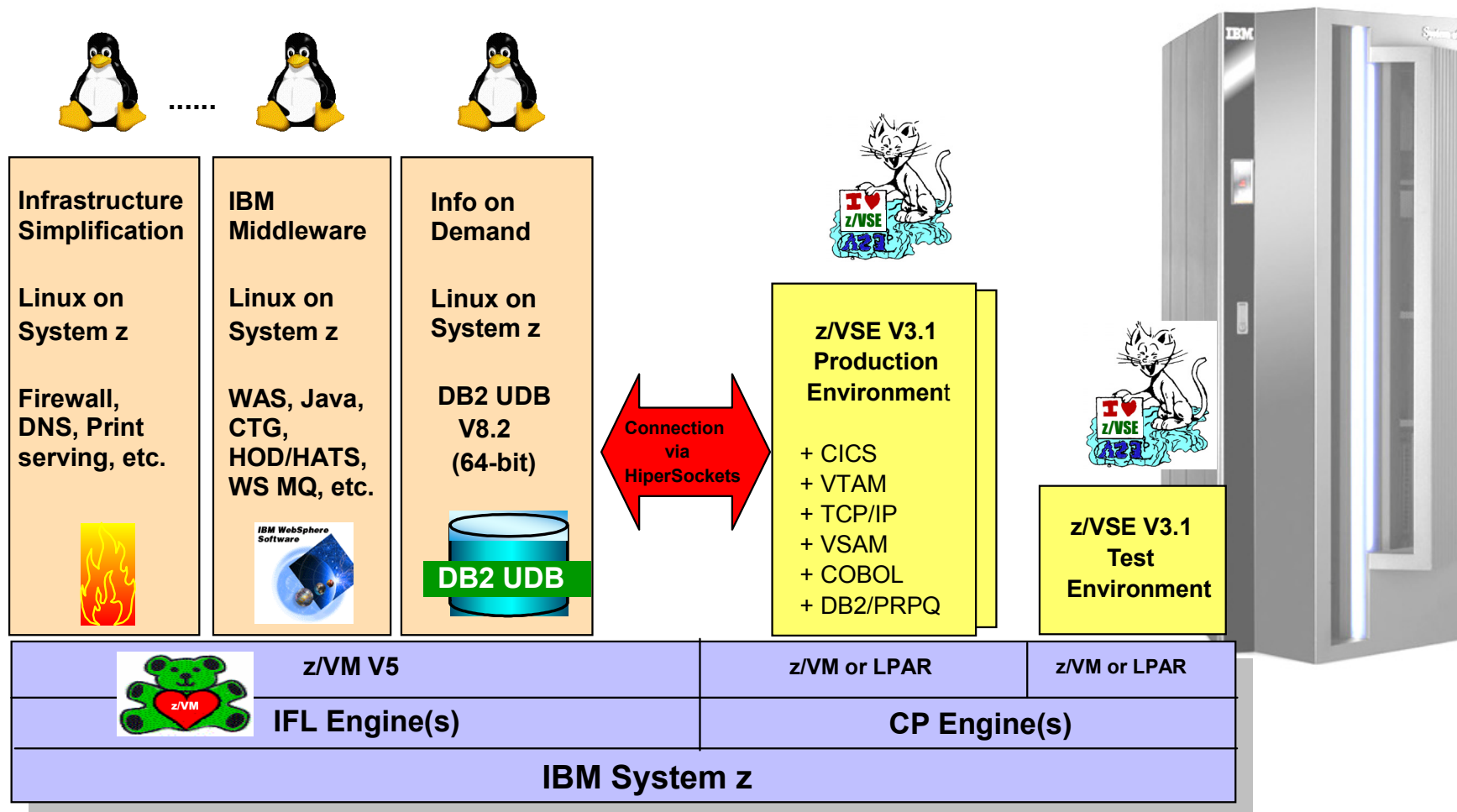

# VSE-related Events

- **GSE FALL 2006**

- October 23-25, 2006
- Nuernberg, DE

- **WAVV 2007 –**

featuring **z/VM, z/VSE, and Linux on System z**

- May 18-22
- Green Bay, WI
- Regency Suites

- **IBM 2007 System z Expo –**

featuring **z/OS, z/VM, z/VSE, and Linux on System z**

- tbd





**Thanks for listening**



**Your friends, the VSE development team**