



E44

z/VSE Hardware Support

Ingolf Salm

zSeries® EXPO

**FEATURING Z/OS, Z/VM, Z/VSE
AND LINUX ON ZSERIES**

September 19 - 23, 2005

San Francisco, CA

Trademarks

The following are trademarks of the International Business Machines Corporation in the United States and / or other countries.

AIX	IBM*	VSE/ESA
CICS*	IBM logo*	VTAM*
DB2*	IMS	WebSphere*
DB2 Connect	Multiprise*	iSeries
DB2 Universal Database	MQSeries*	pSeries
e-business logo*	OS/390*	xSeries
Enterprise Storage Server	S/390*	z/Architecture
FlashCopy		z/OS
HiperSockets		z/VM
		z/VSE
		zSeries

* Registered trademarks of IBM Corporation

The following are trademarks or registered trademarks of other companies.

LINUX is a registered trademark of Linus Torvalds

Java and all Java-related trademarks and logos are trademarks of Sun Microsystems, Inc., in the United States and other countries

UNIX is a registered trademark of The Open Group in the United States and other countries.

Microsoft, Windows and Windows XP are registered trademarks of Microsoft Corporation.

SET and Secure Electronic Transaction are trademarks owned by SET Secure Electronic Transaction LLC.

Intel is a registered trademark of Intel Corporation.

Agenda

- Processor support
- SCSI support
- IBM TotalStorage devices
- Dropped devices
- Documentation

z/VSE 3.1

- Schedules
 - 4/7/2004 – Previewed
 - 2/1/2005 - Announced
 - 3/4/2005 - GA
- Support of Small Computer System Interface (SCSI) devices
- Expand focus on interoperability
 - Especially with Linux on zSeries
- Simplified packaging
 - Language Environment as part of VSE Central Function
- Options for electronic internet delivery and CD-ROM shipment
- z/VSE can execute in 31-bit mode only
- FSU from VSE/ESA 2.6, 2.7 (ECKD devices)

Supported z/VSE Environments

- z/VSE 3.1 runs on ESA/390 and zSeries hardware only
 - ... and supports
 - S/390 Multiprise 3000
 - S/390 Parallel Enterprise Server G5, G6
 - IBM e-server zSeries processors (z800, z900, z890, z990)
 - Equivalent processors based on G5 architecture
 - Linux on zSeries, z/VM V4.x support same architecture level

- Turbo Dispatcher only
 - On all uni- and multiprocessors
 - Native, as z/VM guest or in LPAR

VSE Support for z800 and z890

VSE Version and Release	z800	z890	VSE EoS
z/VSE V3.1	Yes (2)	Yes (2)	tbd
VSE/ESA V2.7	Yes (2)	Yes (2)	tbd
VSE/ESA V2.6	Yes (2)	Yes (2)	03/2006
VSE/ESA V2.5	Yes (2)	No	12/2003
VSE/ESA V2.4	Yes (2)	<u>No</u>	06/2002
VSE/ESA V2.3	No	<u>No</u>	12/2001

Note 1: z/VSE can operate in 31-bit mode only. It does not implement z/Architecture and specifically does not implement 64-bit mode capabilities. z/VSE is designed to support selected features of IBM zSeries hardware

Note 2: 31-bit mode only

SCSI Support for z/VSE

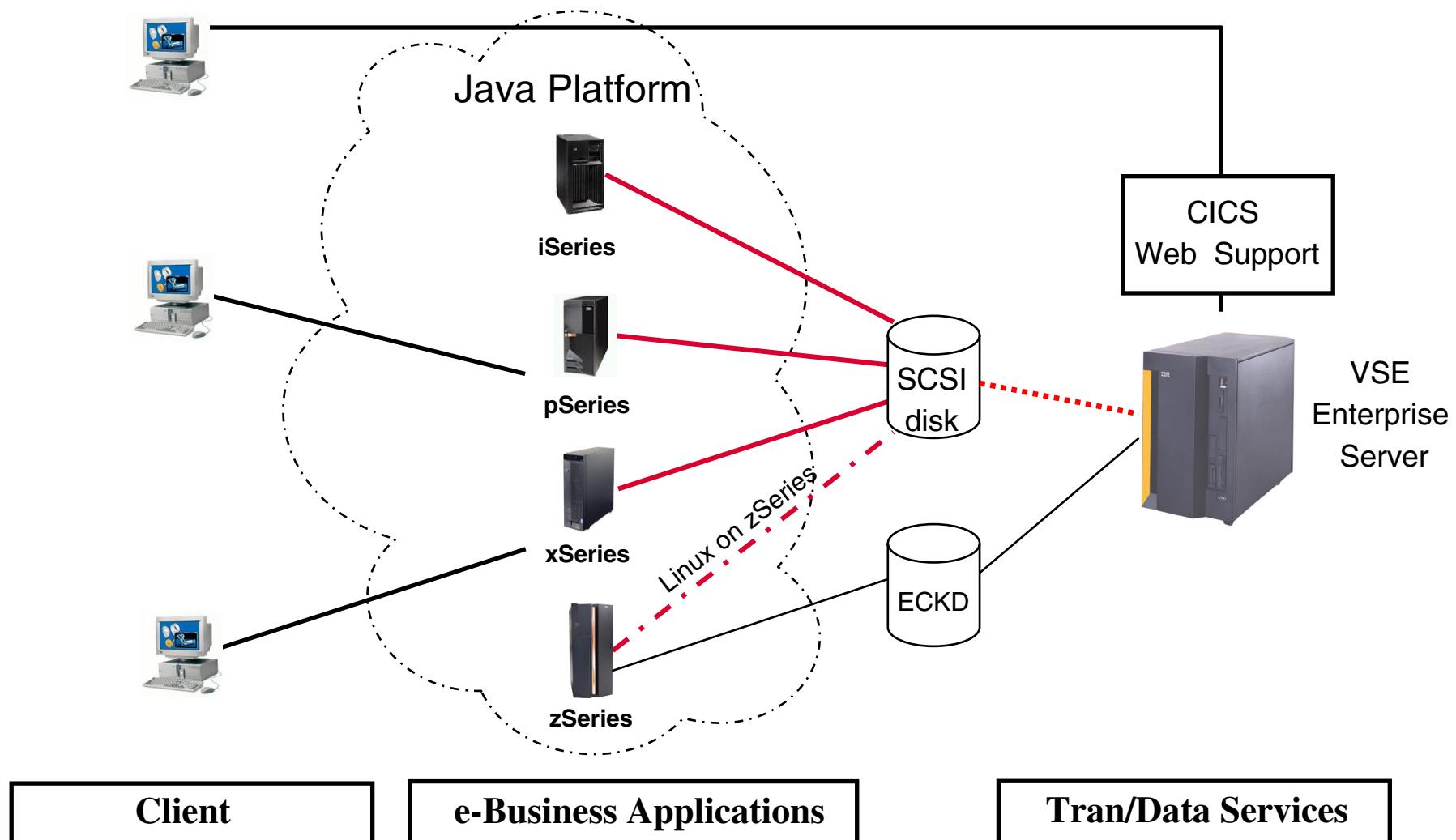

Client

e-Business Applications

Tran/Data Services

Overview - Supported SCSI Environments

- SCSI disks as emulated FBA disks on z/VM 5.1
 - z/VSE supports a max. size of 2 GB
 - Available through z/VSE's FBA support
- Direct attached SCSI disks
 - z/VSE supports up to 24 GB (VSAM: 16 GB)

Overview - SCSI Support in z/VSE

- z/VSE supports SCSI disk devices only
- Impact on applications
 - Transparent to all VSE applications and subsystems,
 - Minimal impact on ISV system management tools
 - Reasons for transparency:
 - z/VSE's SCSI implementation is based on FBA support
 - Applications can not exploit SCSI commands directly
 - FBA to SCSI emulation on low level I/O interface

SCSI Support in z/VSE

- Access SCSI devices through Fibre Channel Protocol (FCP)
 - Support available on zSeries processors
 - OS interfaces
 - Operating system communicates with FCP adapter
 - FCP adapter communicates with the SCSI device
 - SCSI disk devices utilize fixed block sectors
 - Therefore VSE treats them as FBA devices

Overview - SCSI Support – Content / Limitations

- z/VSE's SCSI support includes:
 - SCSI for system (DOSRES, SYSWK1) and data device
 - IPL from SCSI disk
 - Installation to SCSI disk
 - SCSI only system possible
 - Multipathing for fail-over to increase availability
 - "DASD" Sharing (lock file)
- Minimum processor storage: 32 MB
- SCSI support transparent to existing (I/O) APIs
- Not supported:
 - FSU from VSE/ESA 2.6, 2.7 to SCSI device is not possible
 - Standalone dump to SCSI disk
 - Re-IPL from LPAR

Overview - SCSI Support – Content / Limitations

- Block size restricted to 512 bytes, even if the SCSI device can be configured with larger block sizes
 - Emulated as 9336 model 20
- SCSI disk sizes
 - First 4 MB of a SCSI disk are used by VSE internally
 - Not shown externally
 - Minimum size 8 MB
 - Maximum size about 24 GB, VSAM 16 GB
 - Usable size: Defined size (in ESS controller) minus 4 MB
- SCSI Disks must support ANSI SCSI Version 3

Hardware and Software Prerequisite

- IBM eServer zSeries 800, 900, 890 oder 990
- IBM zSeries FCP Adapter
 - Microcode Level:
 - z800 und z900: J11233.015 or higher
 - z890 und z990: J13471.004 or higher
- FCP Switch (e.g. IBM 2109)
- IBM TotalStorage Enterprise Storage Server (ESS)
 - Microcode Level: 2.3.1 or higher
- z/VSE 3.1
- z/VM 4.4 or higher (if running z/VSE as a VM guest)

Hardware and Software Prerequisite ...

- For IPL from SCSI
 - CPU Feature Code 9904
 - z800 and z900:
 - Microcode Level EC-Number J12811 or higher
 - z890 und z990:
 - Microcode Level EC-Number J12221 or higher
- For IPL from SCSI under z/VM 4.4
 - z/VM Service Level:
 - UM31181 (Englisch)
 - UM31180 (German)
 - UM31179 (Kanji)

Overview - SCSI Support - Configuration

- New IPL / JCL commands to define and query a SCSI device
- New IUI dialog to configure SCSI disks
- Required steps to get a SCSI device known to z/VSE
 - Device / Switch configuration
 - FCP Adapter to be configured in IOCDS (CHIPID type FCP)
 - FCP adapter and SCSI disk to be defined in VSE via
 - IPL ADD commands to define FCP and FBA device
 - IPL DEF or JCL SYSDEF command to define connection to LUN

Example - SCSI Network

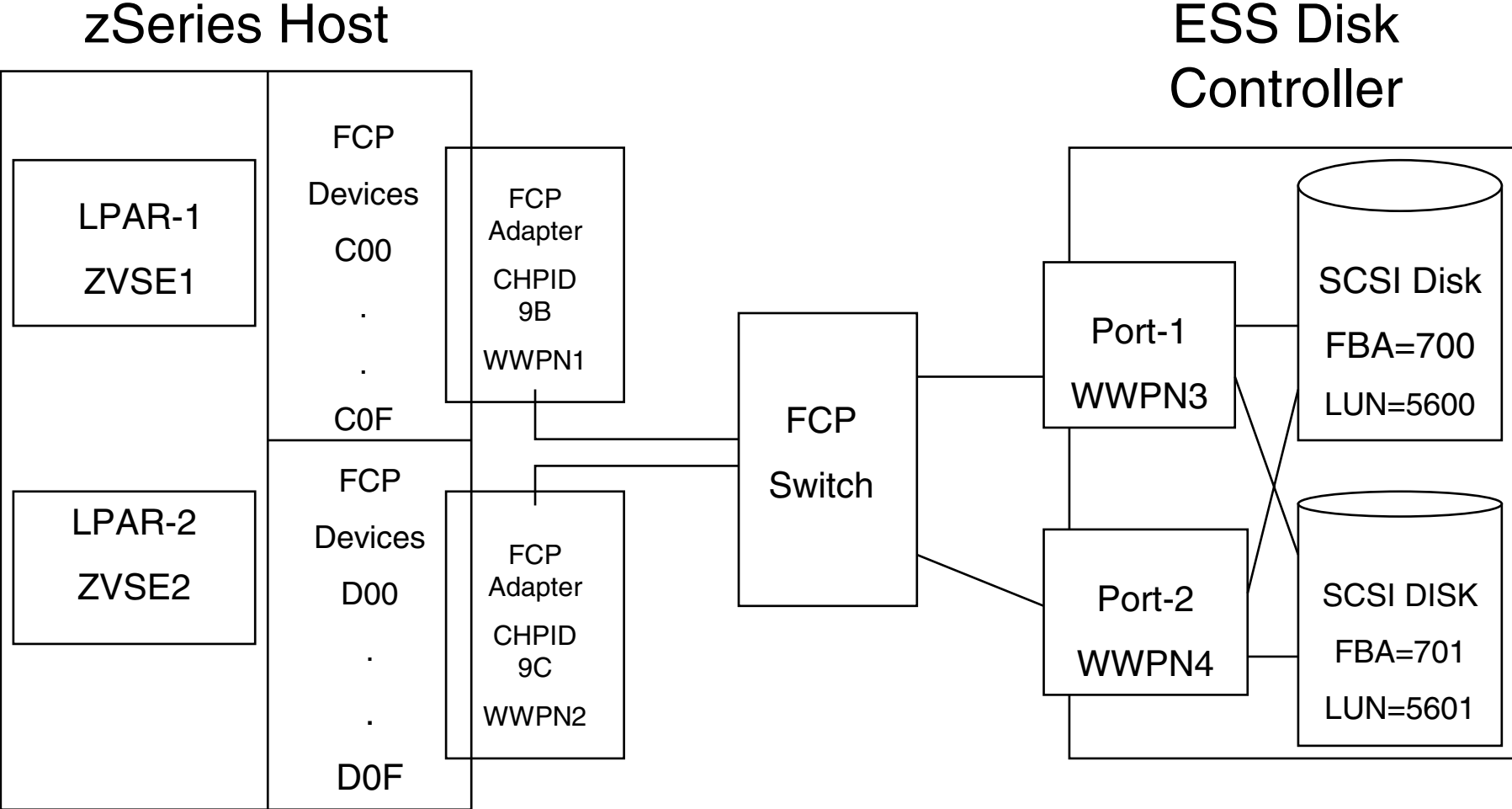

Example - SCSI Configuration

- Configure the FCP Adapters (CHPIDs) using IOCP in zSeries
 - CHPID PATH=(9B),SHARED,
PARTITION=(ZVSE1,ZVSE2),TYPE=FCP
 - CHPID PATH=(9C),SHARED,
PARTITION=(ZVSE1,ZVSE2),TYPE=FCP
 - CNTLUNIT CUNUMBER=0C00,PATH=(9B),UNIT=FCP
 - CNTLUNIT CUNUMBER=0D00,PATH=(9C),UNIT=FCP
 - IODEVICE ADDRESS=(C00,16),
UNITADD=00,CUNUMBR=(0C00),UNIT=FCP
 - IODEVICE ADDRESS=(D00,16),
UNITADD=00,CUNUMBR=(0D00),UNIT=FCP
- The number of IODEVICEs per CHPID and the number of CHPIDs per card are model dependent

Example - SCSI Configuration

- Configure the SCSI Disks in the ESS Controller
 - Note : SCSI Disks are not configured in the IOCP
 - Define the FCP Adapter (WWPN1, WWPN2)
 - Host-Type determines the format of the LUN (use e.g. RS/6000)
 - ESS Ports that can be accessed by the FCP adapter ...
 - Configure the ESS Ports
 - Fibre Channel Topology - Switched Fabric
 - Fibre Channel Protocol – FCP (Open Systems)
 - Define the LUNs (number, size)
 - Specify Access to the LUNs
 - Allow FCP Adapter (WWPN) to access the LUN

Example - SCSI Configuration

- IPL from SCSI
 - LPAR or native (basic mode)
 - Via Hardware Management Console (HMC)
 - Load address (FCP device) – C00
 - WWPN3
 - LUN – 56000000 00000000
 - As z/VM guest
 - SET LOADDEV PORTNAME WWPN3 LUN 56000000 00000000
in z/VM guest directory

Example - SCSI Configuration

- Define FCP Devices, SCSI Disks and Connection Paths to z/VSE
 - ADD C00,FCP (ADD C00:C0F,FCP)
 - ADD D00,FCP (ADD D00:D0F,FCP)
- FBA Devices:
 - ADD 700:701,FBA
 - Note: these devices must not exist in the IOCP or under VM
- Define a Connection Path (IPL)
 - DEF SCSI,FBA=700,FCP=C00,WWPN=5005076300CA9A76,LUN=5600
 - DEF SCSI,FBA=701,FCP=C00,WWPN=5005076300CA9A76,LUN=5601
 - Only one FCP cuu needed to access the LUNs
- Define a Connection Path (after IPL)
 - SYSDEF SCSI,FBA=702,FCP=C00,WWPN=5005076300CA9A76,LUN=5602
 - Note: The FBA and FCP devices must have been added during IPL.

Example - SCSI Configuration

- Multipathing

- More than one connection path exists to a SCSI Disk (LUN)

- DEF SCSI,FBA=700,FCP=C00,WWPN=5005076300CA9A76,LUN=5600
 - DEF SCSI,FBA=700,FCP=D05,WWPN=5005076300C69A76,LUN=5600

- To increase availability of a SCSI disk

- If one connection path fails, the system switches to the next available
 - Connection path must use different FCP adapter (CUIPID) or better FCP card

- QUERY SCSI

AR	FBA-CUU	FCP-CUU	WORLDWIDE PORTNAME	LOGICAL UNIT NUMBER
AR 0015	700	C00	5005076300CA9A76	5600000000000000
AR 0015	700MP	D05	5005076300C69A76	5600000000000000

Example - SCSI Configuration

- „DASD“ Sharing
 - Lock file on SCSI disk
 - Not allowed on system device (DOSRES, SYSWK1)
 - Multipathing not supported
 - Recommendation: define SCSI disk that just holds the lock file
 - VSE systems sharing SCSI disks needs own FCP adapter (CHPID) to access lock file
 - VSE1: Connection Path to Lock File device
DEF SCSI,FBA=600,FCP=C00,WWPN=...,LUN=5700
---- FCP device is on CHPID=9B
 - VSE2: Connection Path to Lock File device
DEF SCSI,FBA=800,FCP=D00,WWPN=...,LUN=5700
---- FCP device is on CHPID=9C

SCSI Related AR Commands

- VOLUME (FBA) cuu

```
AR 0015 CUU CODE DEV.-TYP  VOLID USAGE  SHARED  STATUS  CAPACITY
AR 0015 700 90      1732-FCP DOSRES USED                1944831 BLK
```

- CANCEL (FBA) cuu, FORCE

– Terminates ongoing I/O commands against SCSI device

- CANCEL (FCP) cuu – Ignored

- STATUS (FBA) cuu

```
AR 0015 DEVICE IS AN FCP-CONTROLLED SCSI DEVICE
```

```
AR 0015 PUB=00004608 PUBX=000B0510 PUB2=000ADE82 POWN=00006520
```

```
AR 0015 VCTE=000AD9D0 POWNX=002B6DF4
```

SCSI Related AR Commands ...

- OFFLINE (FBA) cuu

```
AR 0015 CUU CODE DEV.-TYP  VOLID  USAGE  SHARED  STATUS  CAPACITY
AR 0015 700  90    1732-FCP DOSRES  USED           NOT OPER.  1944831 BLK
```

- OFFLINE (FCP) cuu

AR+0015 1I55D CANCEL FCP-SCSI ? REPLY YES OR NO

- All connection pathes using this FCP cuu are closed
- LUNs no longer accessible via this FCP cuu
- All ongoing I/Os (against LUNs) are terminated if no alternate path is available

- ONLINE (FCP) cuu

- The system recovers all connection pathes with the FCP cuu
- Issued after successful completion of FCP (cuu) recovery

zSeries Exploitation

- OSA Express2 – new generation of zSeries LAN adapters
 - 10 Gigabit Ethernet (higher network bandwidth)
 - Supported in QDIO mode
 - Gigabit Ethernet
 - Supported in QDIO mode
 - z/VSE 3.1 supports up to 640 TCP/IP stacks (connections) per dedicated CHIPID (support of 1920 devices)
- HiperSockets
 - Spanned channels – across different LCSSs
- Spanned external channels
 - FICON Express2 / Express, OSA Express 2 / Express adapters across multiple LCSSs
- FICON Express 2 / Express
 - Higher I/O bandwidth
- Adapter interruptions
 - Available on z890 and z990
 - Performance improvements can be expected for OSA Express2/Express (QDIO mode), FICON Express2/Express (FCP)

zSeries Exploitation ...

- OSA Express Integrated Console Controller (OSA-ICC)
 - Available on z890 and z990 servers
 - May eliminate the need for non-SNA 3174 controllers or replace existing 3174 and 2074 controllers
- Cryptographic assists - Exploited by TCP/IP SSL support transparently
 - CPACF – for symmetric encryption
 - PCICA (crypto card) – for asymmetric encryption
 - Crypto Express2 – for asymmetric encryption
 - Only PCICA function supported
 - Will be support via PTF at a later time
- Up to 30 LPARs
- Up to 4 LCSSs
 - z890 supports up to 2 LCSSs, z990 up to 4 LCSSs

zSeries Storage Options

IBM TotalStorage	DS6000	ESS 750	ESS 800 & 800Turbo	DS8000
ESCON	No	Yes	Yes	Yes
FICON	Yes	Yes	Yes	Yes
FCP/SCSI	Yes (1)	No	Yes	Yes (1)

Note 1: z/VSE V3.1 DS8000 and DS6000 SCSI qualification date tbd

Exploitation of IBM TotalStorage Products

- IBM TotalStorage 3494 Virtual Tape Server (3494 VTS)
 - 3494 Tape Library supports 3490E, 3590, 3592 tape drives and 3592 WORM media
 - Support through S/390 channel command interface via
 - Perform Subsystem Function (PSF)
 - Perform Library Function (PLF) commands
 - No support of import/export functions
 - Existing LCDD (native VSE and VGS (VSE as VM guest))
 - Support based on XPCC/APPC protocol
 - Not enhanced; does not support 3592 tape drives
 - VTS microcode level 2.31.730.54 or higher required
- IBM TotalStorage 3592 Enterprise Tape Drive J1A
 - High capacity, fast access media (300 GB / 60 GB cartridges)
 - Cartridges in WORM format for long-term records retention

Exploitation of IBM TotalStorage Products

- IBM TotalStorage Servers
 - Via ESCON (not DS6000), FICON, FCP channels
 - IBM TotalStorage Enterprise Storage Servers (ESS)
 - DS6000, DS8000
 - SCSI disks supported at a later time
 - Available PTFs for ECKD
 - VSE/ESA 2.7: UD52668 (APAR DY46208) – support of DS6000, DS8000, FlashCopy V2
 - z/VSE 3.1: PTF UD52673 (production), UD52674 (generation), APAR DY46217

Exploitation of IBM TotalStorage Products ...

- Flashcopy V2 support
 - Improved FlashCopy – NOCOPY option
 - Direct copy to backup device
 - Datasetcopy
 - Source and target volumes may have different sizes
 - should not be used for VSAM files
 - Elimination of Logical Subsystems
 - Source and target volume can span LSS
 - Multiple relationship FlashCopy
 - Up to 12 volumes from one source in a single FlashCopy operation
 - Peer-to Peer Remote Copy (PPRC) Version 2
 - Allows remote data replication
 - Supported via ICKDSF
 - Not supported by z/VSE
 - Incremental FlashCopy
 - Consistency group commands
 - Inband commands over remote mirror link
 - Available PTF's
 - VSE/ESA 2.7: UD52668 (APAR DY46208) – FlashCopy V2
 - z/VSE 3.1: UD52673 (production), UD52674 (generation), APAR DY46217, DY46233

Dropped Devices - General

- drop means:
dropped from ADD statement, drop from IUI and/or documentation
- 'generic FBA' support is retained for all FBA disks
- 9345 dropped completely (as system and data device)
- 3420 (T7 and T9) will be retained as last tape reel device

Drop Devices DASD

Device Dropped	Type in ADD Stmt	Replaced by ADD Stmt	Comments
0671	FBA	FBA	No longer usable with VSE 2.7 (P/390) replaced by Generic FBA
3370	FBA	FBA	Replaced by generic FBA
3375	3375	NONE	No replacement
3995	ECKD	ECKD	Dropped from documentation and IUI
9332	FBA	FBA	No longer usable with VSE/ESA 2.7 (ES/9221), replaced by generic FBA
9335	FBA	FBA	No longer usable with VSE/ESA 2.7 (ES/9221) replaced by generic FBA
9336	FBA	FBA	No longer usable with VSE 2.7 (ES/9221) replaced by ,Generic FBA'
9345	ECKD	NONE	Drop as SYSRES and data device (special track structure)

Dropped Devices Tapes

- Tape devices
 - 2440 (no longer usable with VSE/ESA 2.7 – ES/9221)
 - 3422
 - 3424
 - 3430
 - 9346
 - 9347 (no longer usable with VSE/ESA 2.7 – ES/9221)
 - 9348 (no longer usable with VSE/ESA 2.7 – ES/9221)
 - Only tape reel device is 3420 T7 and T9

Dropped Devices

- Other devices
 - CETI (no longer usable with VSE/ESA 2.7 – ES/9221)
 - ICA dropped from documentation only
(no longer usable with VSE/ESA 2.7 – ES/9221)
 - 2701 and 2703 dropped from documentation only,
old device not Y2K ready
 - 3705, 3720 dropped from documentation only
 - 3540 dropped from documentation only – diskette drive, not Y2K ready
 - 3890, 3895 dropped from documentation only
 - 3881, 3886 – optical reader

z/VSE 3.1 (Hw Crypto + HiperSockets + SCSI disks)

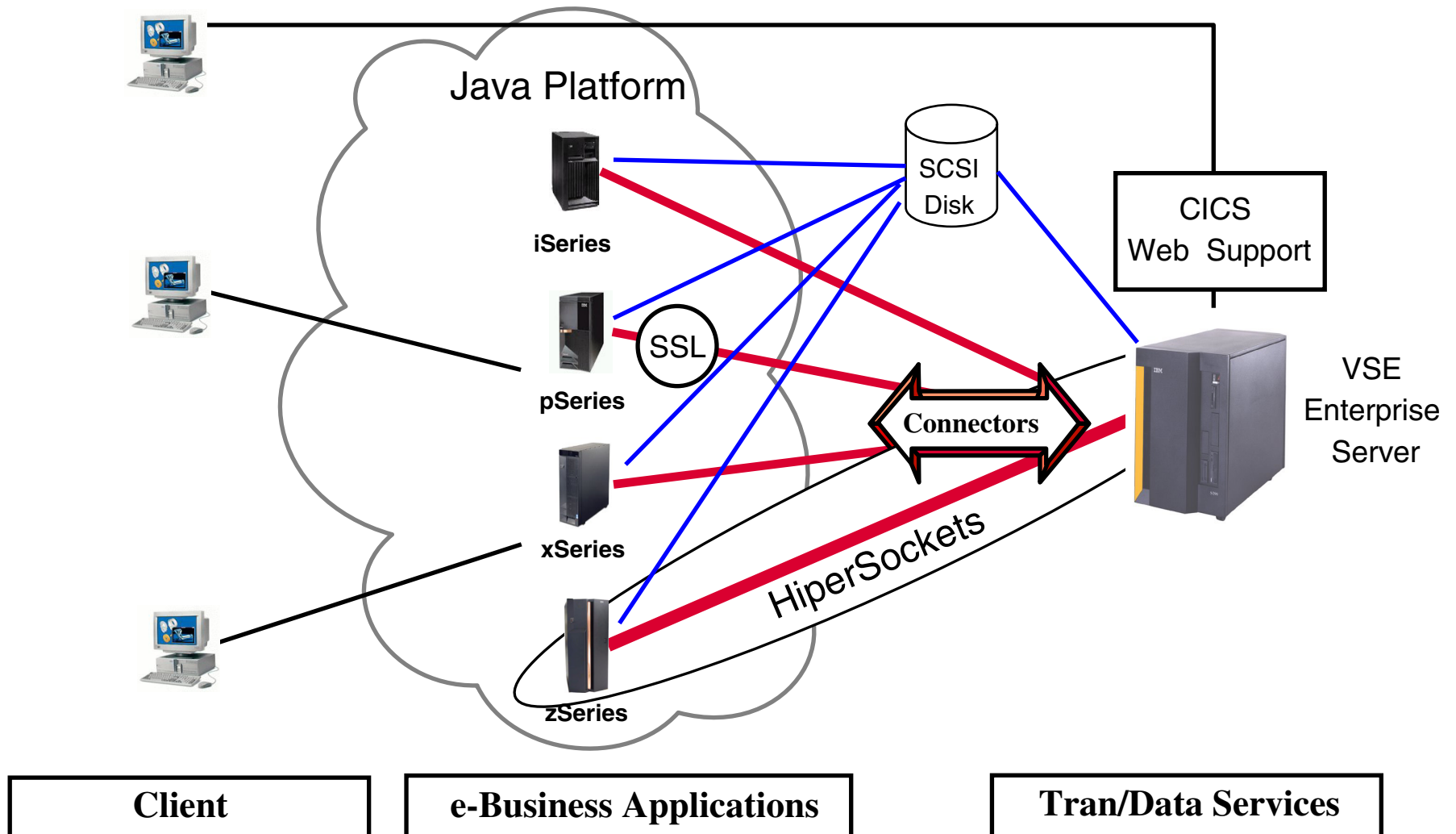

Documentation

- Connectors for z/VSE
<http://www.ibm.com/servers/eserver/zseries/os/vse/support/vseconn/>
- e-business Connectors User's Guide, SC33-6719
- Redbook: Getting Started with TCP/IP for VSE/ESA 1.4, SG24-5626
- Redbook: e-business Solutions for VSE/ESA, SG24-5662
- Redbook: e-business Connectivity for VSE/ESA, SG24-5950
- VSE Applications - How e-business Fits, GF22-5137
- Hints and Tips for VSE/ESA, SC33-6757
- z/VSE home page
<http://www-1.ibm.com/servers/eserver/zseries/zvse/>