



Session B04

Why FICON: The Basics

Brian Hatfield

zSeries® EXPO

**FEATURING Z/OS, Z/VM, Z/VSE
AND LINUX ON ZSERIES**

September 19 - 23, 2005

San Francisco, CA

Session Objectives

In this session we will Identify or Define;

- Why the FICON channel is needed in the large enterprise environment
- FICON operating modes and differences between ESCON
- Potential sharing of resources between the open system and enterprise system environment
- Terminology that will be used in both Open and Enterprise systems
- zSeries FICON channel adapters and cabling/connector usage

The Coming FICON Evolution (1 of 2)

In the latter half of 1990s IBM recognized;

- Architectural limit of 256 channels
 - Customers at or approaching channel connectivity constraint
- Control units and devices being developed that would exceed the ESCON channel 1024 device address limitation (per channel)
- Extended distance requirements
 - ESCON performance droop past 9 km

The Coming FICON Evolution (2 of 2)

- High fiber costs when connecting multiple data centers
- Distance limitations for dark fiber and ESCON
- CMOS MIP growth is outpacing existing channels
 - Higher bandwidth channels needed for a balanced system
- Future application requirements
- Future device requirements

Potential S/390 I/O Solutions

<div style="text-align: right;">Solution</div> <div style="text-align: left;">Effect</div>	More Channels	Faster Channels	New Channels
Relief for 256 Channel Connectivity Limit	Yes	No	Yes
Increased Distance Support	No	No	Yes
Improved Performance	No	Yes	Yes
Improved Bandwidth	No	Yes	Yes
Enhanced Connectivity	No	No	Yes
Reduced Complexity	No	No	Yes

Objectives with FICON

- Industry Standard (Fibre Channel Standard)
- Improve Performance (high bandwidth/data rate)
- Improve Connectivity, for example,
 - Distance
 - Topology choices
 - Switch Management
- Reduce Complexity (channel aggregation)
- Help protect customer's existing investment
 - Supplement, not replace, ESCON
 - Physical cabling (reuse existing MM or SM)
 - Channel-type mix (FICON and/or ESCON)
- A broad-based, today and future-oriented solution

FICON Operating Modes

zSeries and G5/G6 FICON Configuration

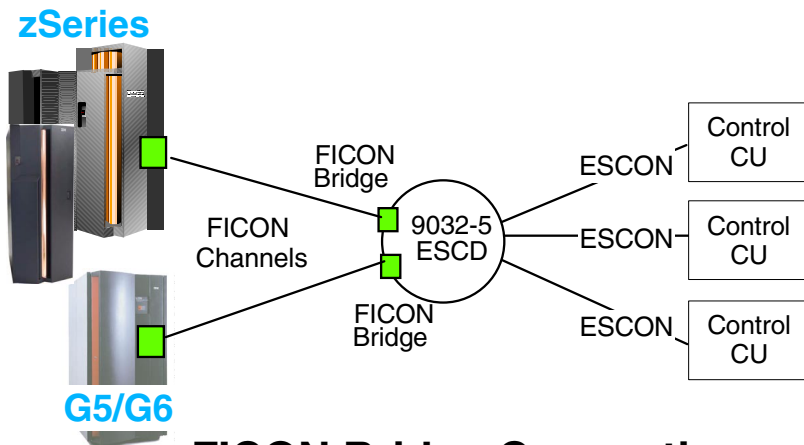

**FICON Bridge Connections:
Type=FCV**

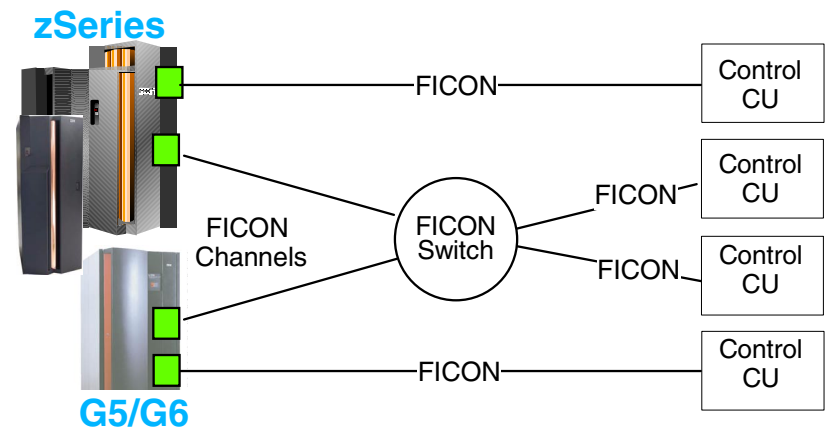

**FICON point-to-point and switched
point-to-point: Type=FC**

System z9 and zSeries Only FICON Configuration

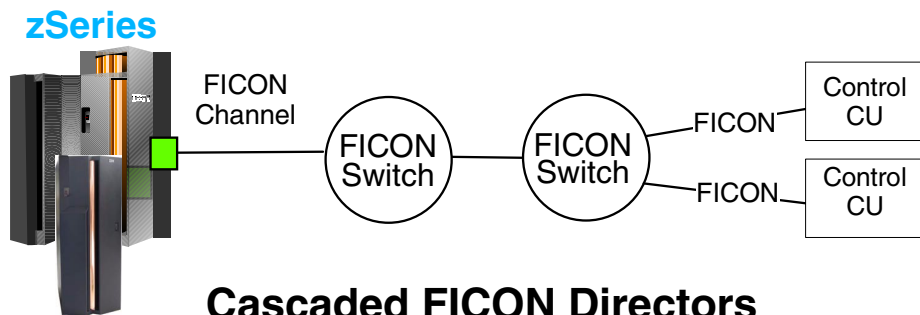

**Cascaded FICON Directors
Type=FC**

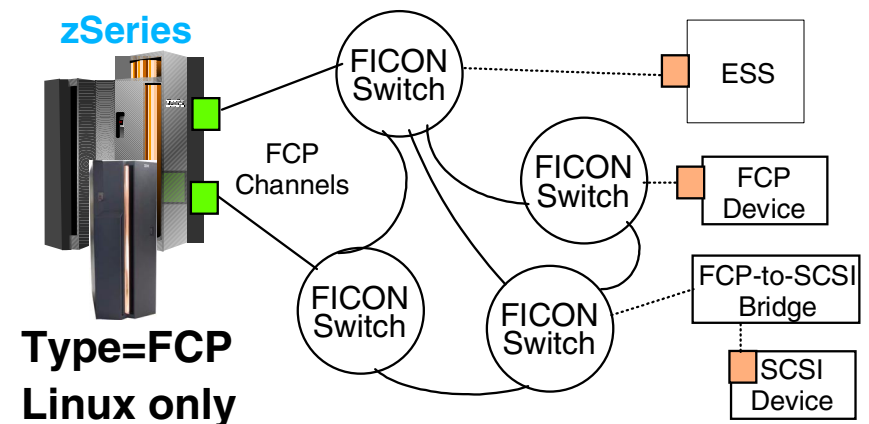

**Type=FCP
Linux only**

FICON Server Support

IBM Fibre CONnection = FICON

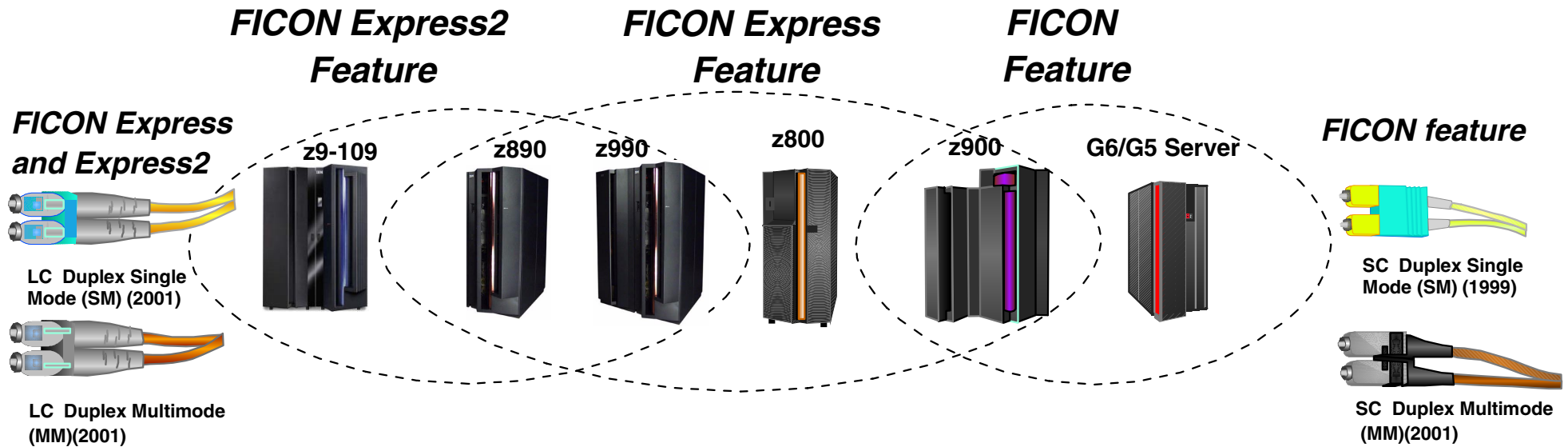

- **FICON feature (100 MB/s)**
 - Original FICON adapter introduced on 9672 G5
 - 100 MB FICON feature cards supported on 9672 G5/G6 and z900
- **FICON Express and Express2 (200 MB/s)**
 - Express supported on all zSeries
 - Express2 supported on z890/z990 and System z9-109

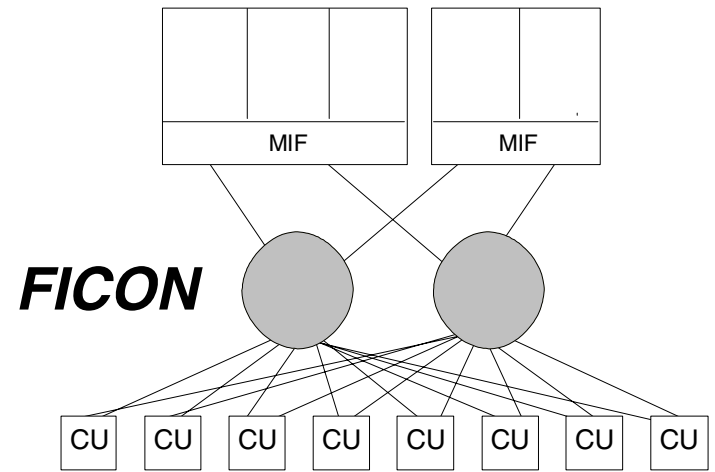

FICON Feature OS Support

FICON, FICON Express and FICON Express2 Features are supported by zSeries OS in either LPAR or BASIC mode

- FICON and FICON EXPRESS - CHPID types FC and FCV
 - z/OS and z/OS.e
 - z/VM(including Linux)
 - VSE / ESA Version 2.6 and later
 - TPF Version 4.1 and later
- FICON EXPRESS2 - CHPID type FC
 - z/OS and z/OS.e V1.3 and later
 - z/VM 3.1 and later (including Linux)
 - VSE / ESA Version 2.6 and later
 - TPF Version 4.1 at PUT 16 and later
- FICON CHPID type FCP
 - z/VM 4.4 and later
 - Linux (current available distributions)

FICON(FCV) Bridge vs. ESCON Frame Process

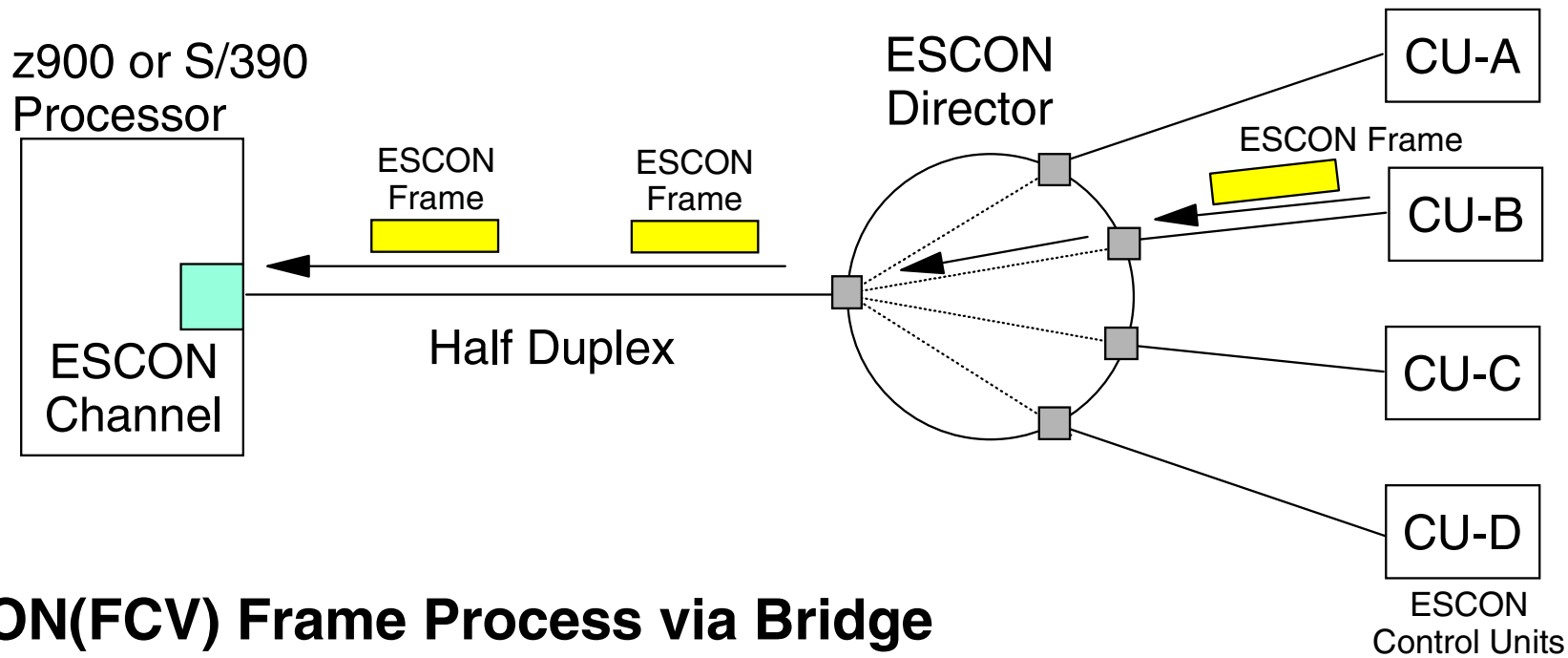

FICON(FCV) Frame Process via Bridge

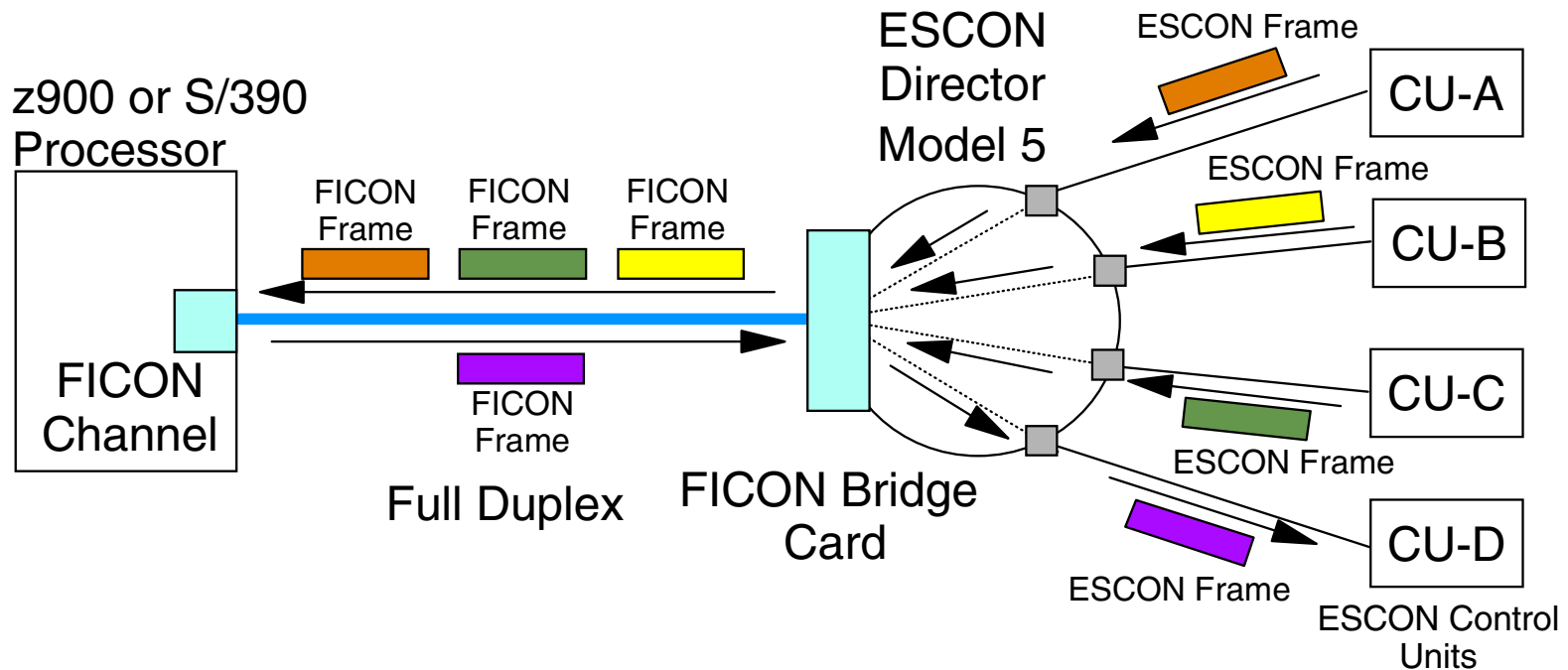

ESCON to FICON Bridge Aggregation

Before

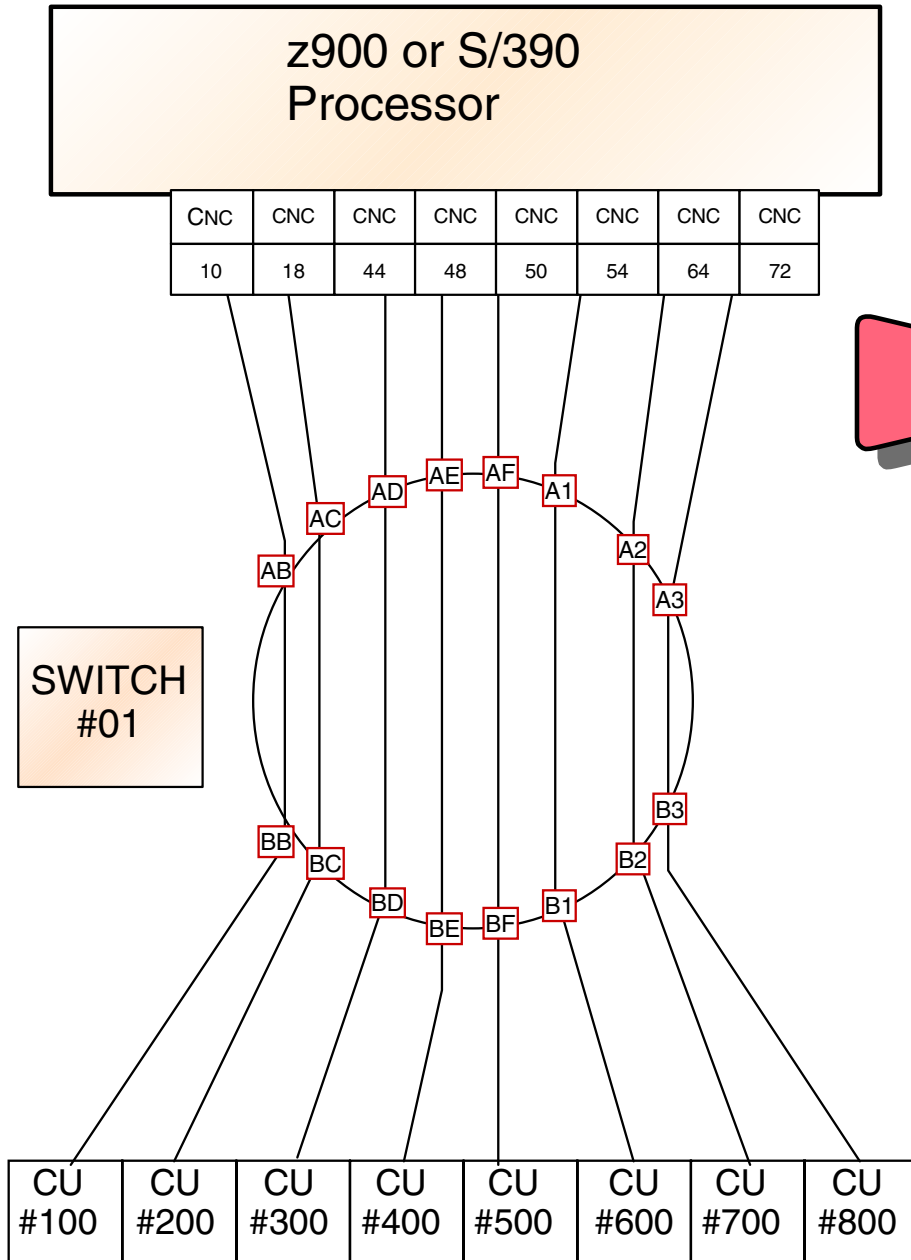

After

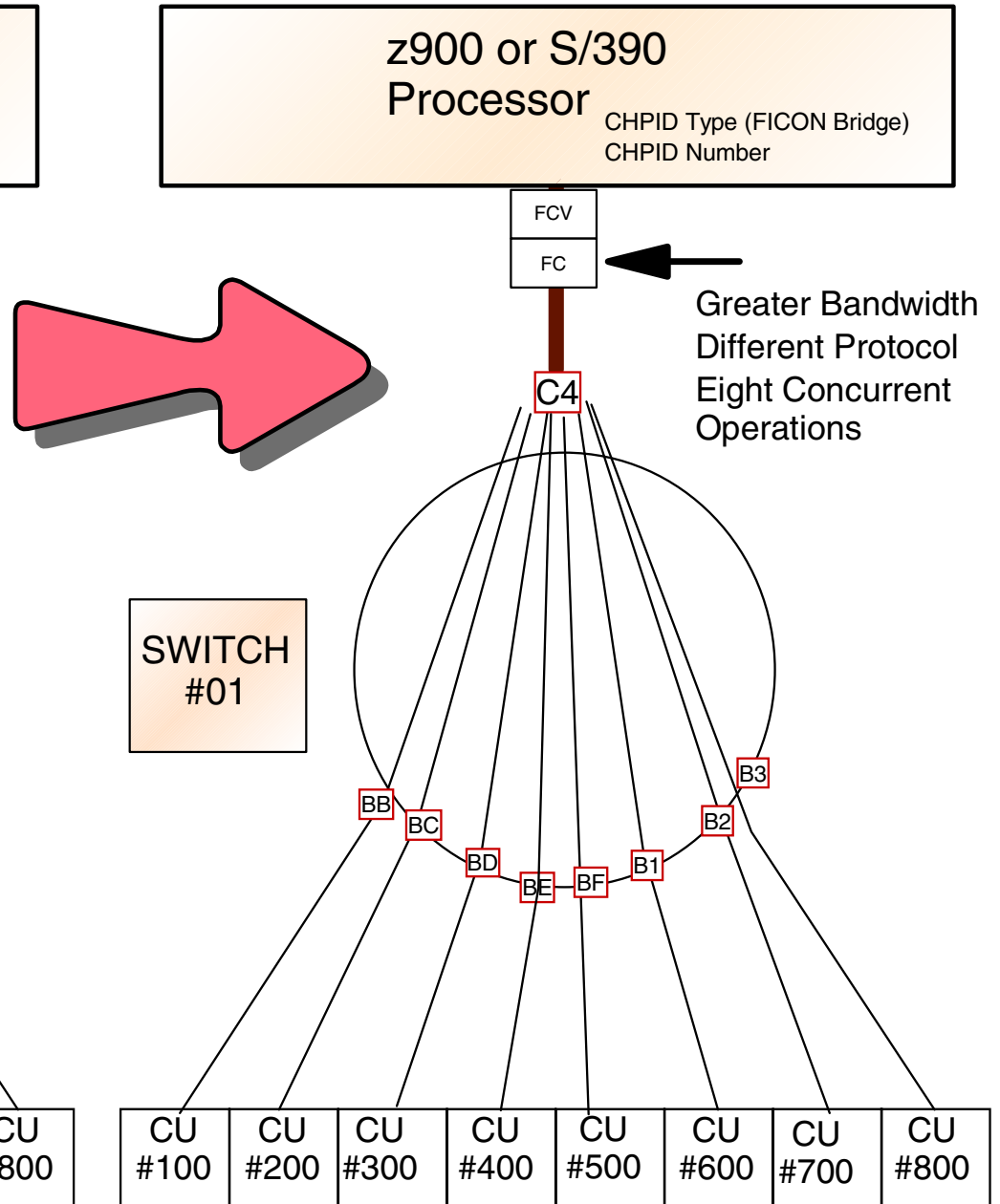

FICON(FC) vs. Frame Process Native

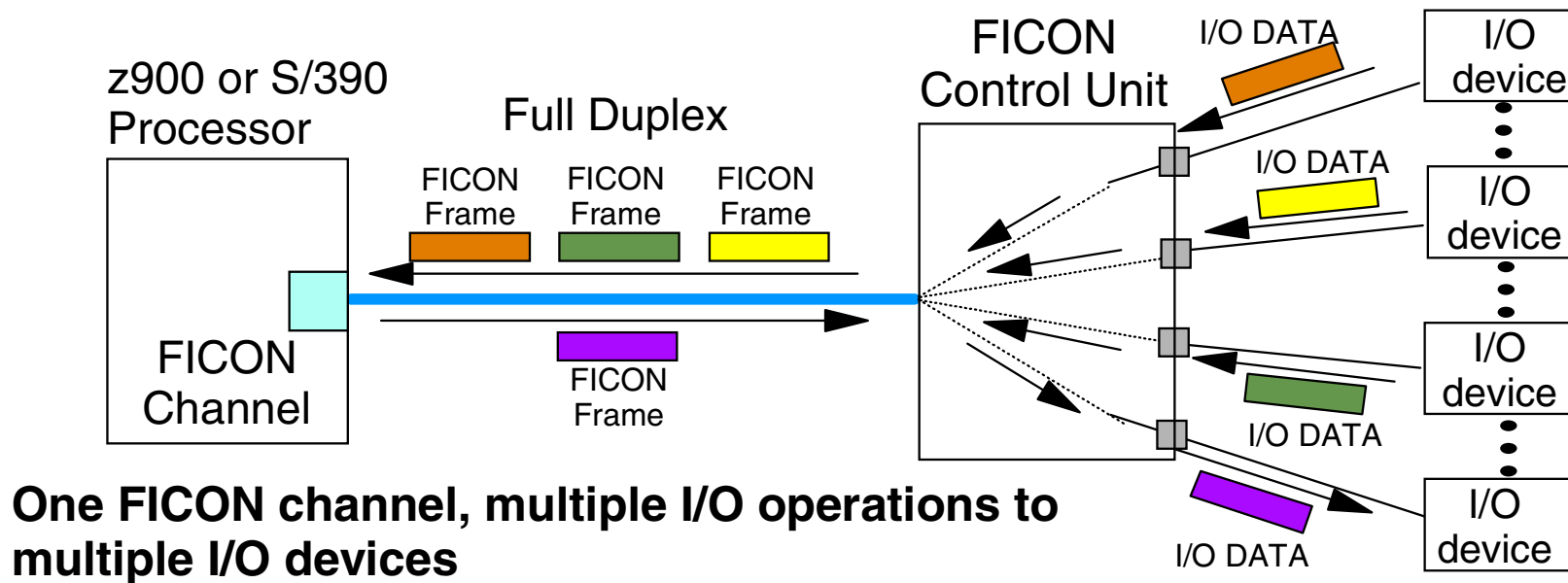
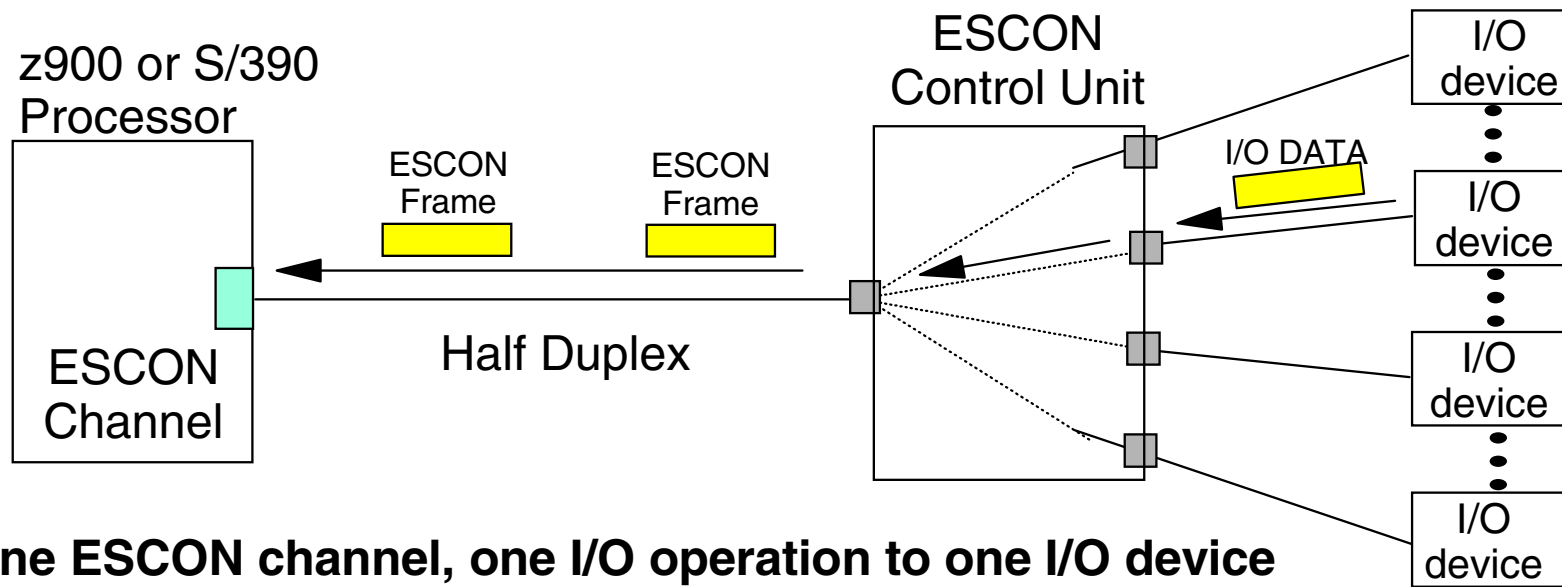

FICON Native Configuration

Before

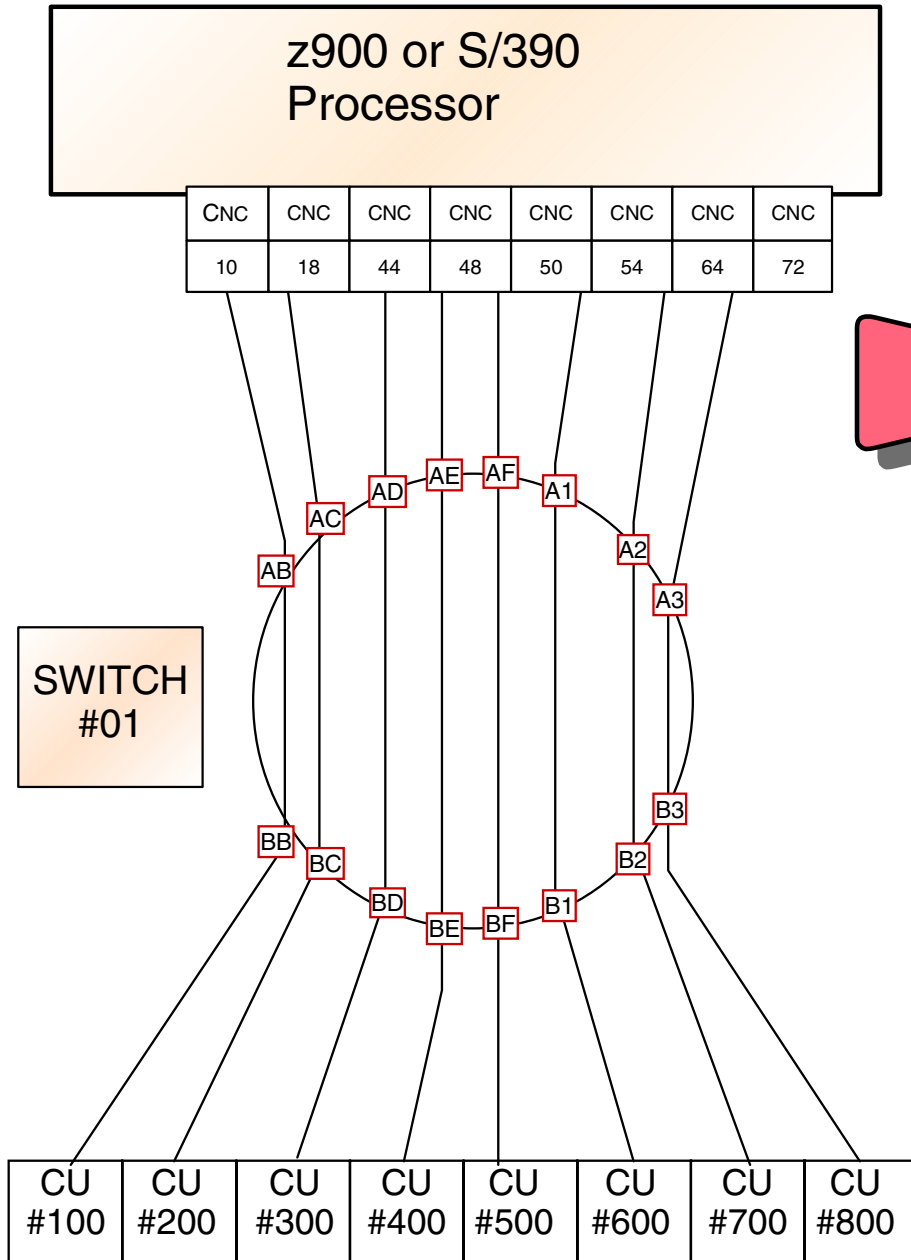

After

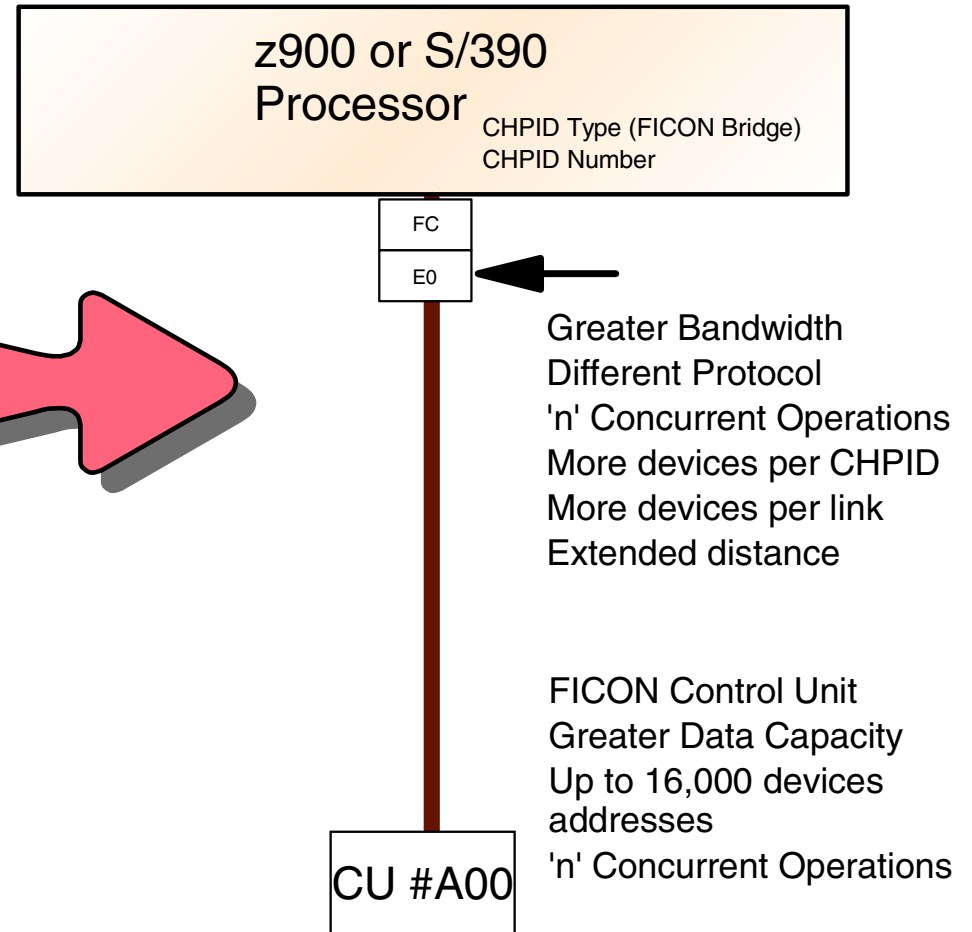

ESCON to FICON Differences

- ESCON protocol uses an interlocked approach
 - One I/O Operation at a time
 - One CCW at a time
- FICON exploits the Fibre Channel Standard to provide
 - Multiple concurrent I/O Operations over the same channel
 - CCW Pipelining
 - Multiple CCWs sent to a single control unit, I/O device
 - CCW Multiplexing
 - Multiple CCWs sent to multiple control units, I/O devices

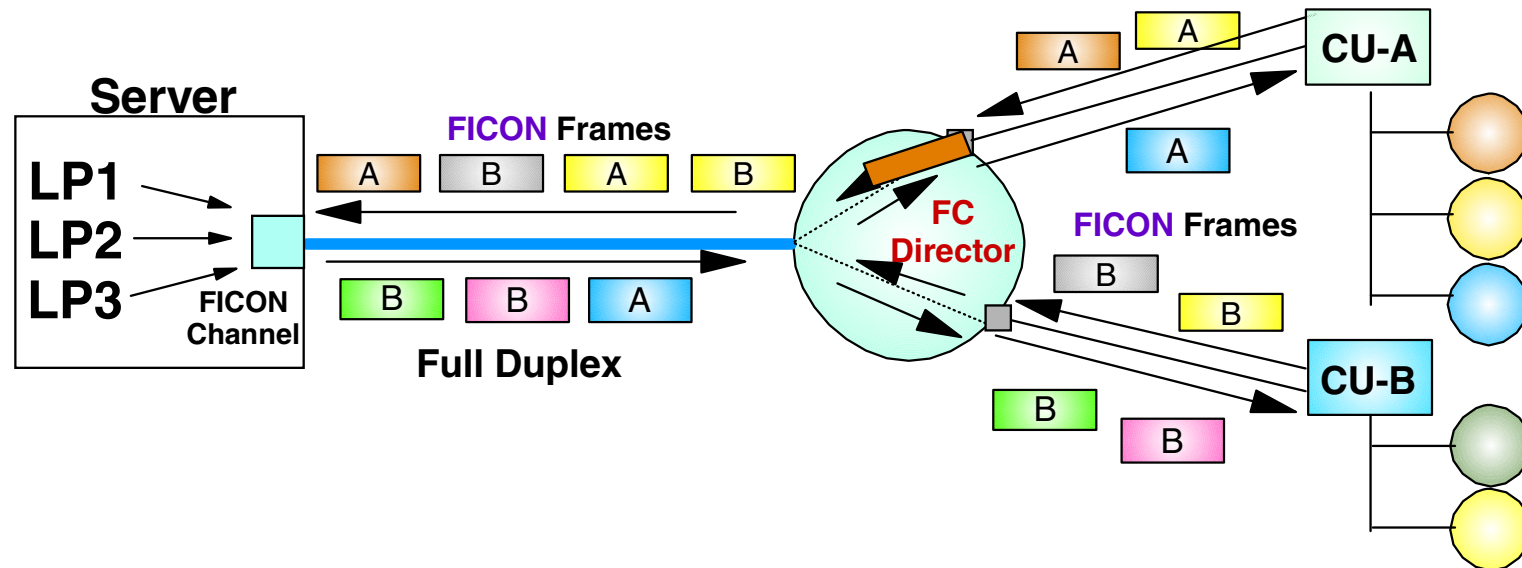

Fibre Channel Architectural levels

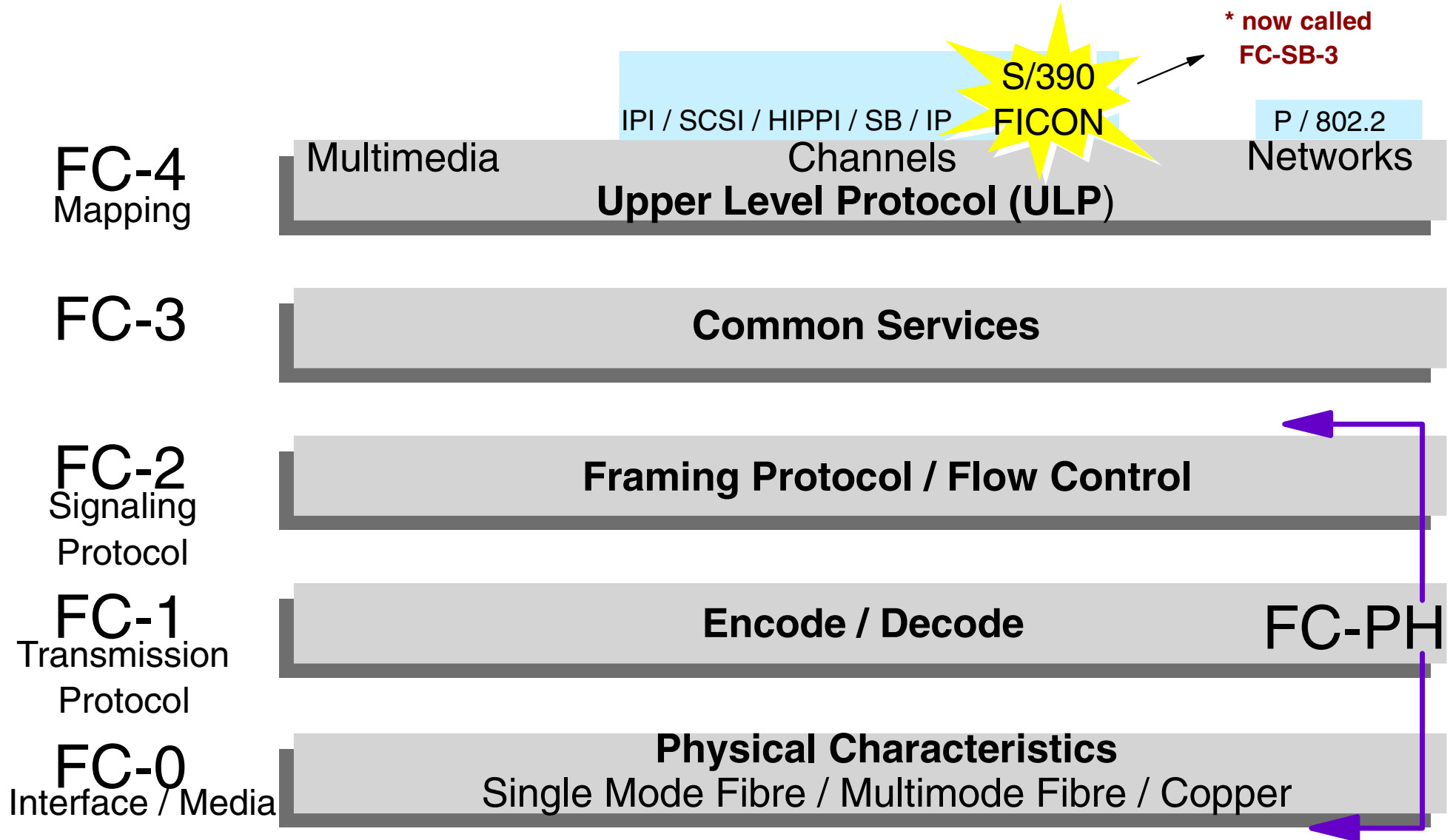

FICON built on Fibre industry standard

FICON Architectural Characteristics

- Topology: Point-Point or Switched
- Protocol: Point - Point
- Class of service: Primarily FC Class 3
- Greater FC link rate
 - Currently up to 200 MB/sec
- Distance 100 km capacity without data droop
 - Point-to-Point capability of 10 km (RPQ for additional distance)
- 256 CU images addressable at CU port
 - Versus 16 for ESCON
- 64 KB devices addressable at CU port
 - 256 CU images x 256 devices per image
 - Versus 4,000 for ESCON
- CCW Pipelining and Multiplexing

FICON Objectives

Meet applications requirements for a better I/O channel and connectivity requirements for SAN environment

- Future applications
 - Data warehousing
 - Imaging
 - Audio/video
 - High-performance communications
- Application requirements
 - Connectivity
 - Bandwidth
 - Performance
 - Availability
- Multiplatform connectivity
- Future device requirements
 - Disk
 - Higher number of devices
 - Very high capacity Disk CUs
 - High performance
 - Long-distance attach
 - Tape
 - High throughput
 - Long-distance attach

Multiplatform Connectivity

Enterprise Systems

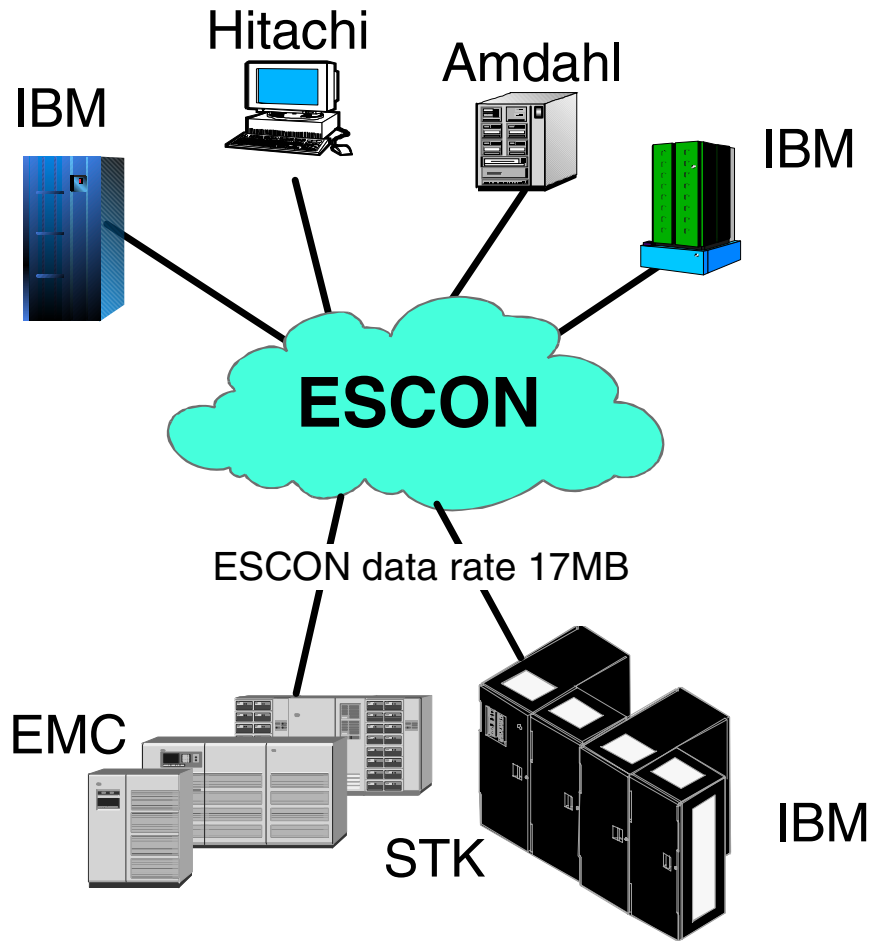

- Mature environment
- Storage shared OS/390 only

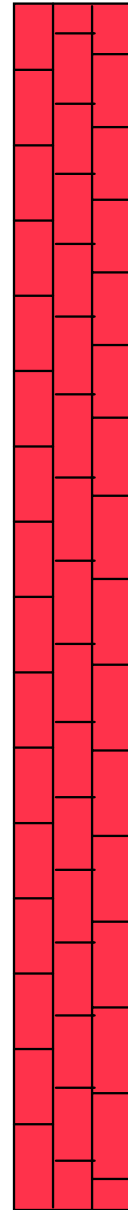

Open Systems (SAN environment)

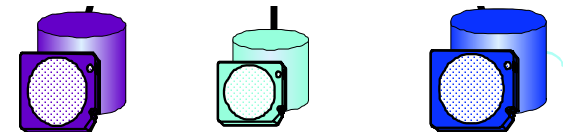
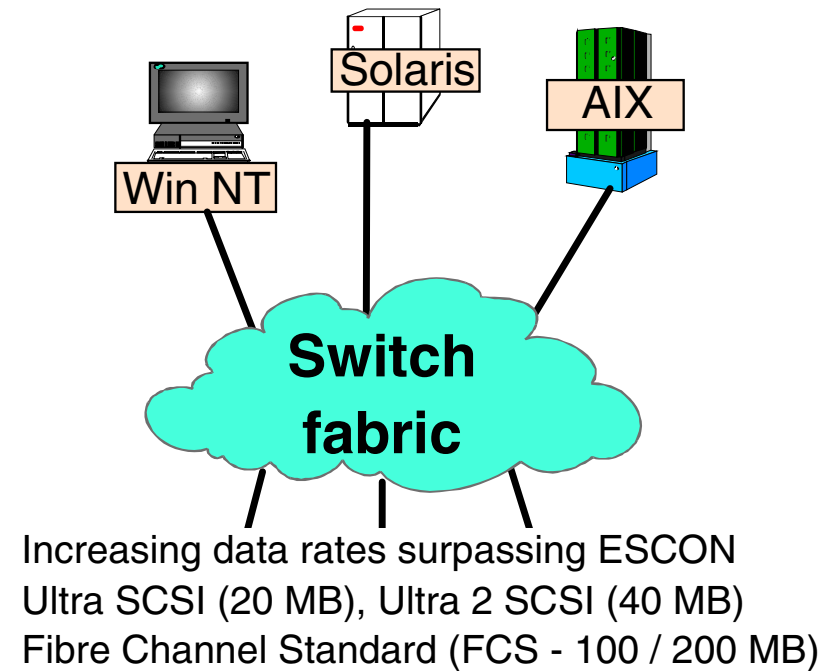

- Explosive growth
- Storage consolidation
- Industry standards fibre channel

Today's Challenge

- Multiple Server platforms
- Server consolidation
- Shared storage requirements (including SAN)
- Communication between Enterprise system group and Open Systems group not always optimal
- Many connectivity options (channel and connectors)
 - Different channels types
 - Different channel usage (Network and I/O)
 - Channel bandwidth capacity
 - Different cabling requirements
- Distance limitations
- Number of channels
 - Architectural limit of 256 channels
 - Channel definition process

SAN Fabric Switches and FICON

Some FCS directors and switches may be used in either the Open environment, Enterprise environment or both

These directors may already exist in your data center and it may just be a matter of loading the FICON code support

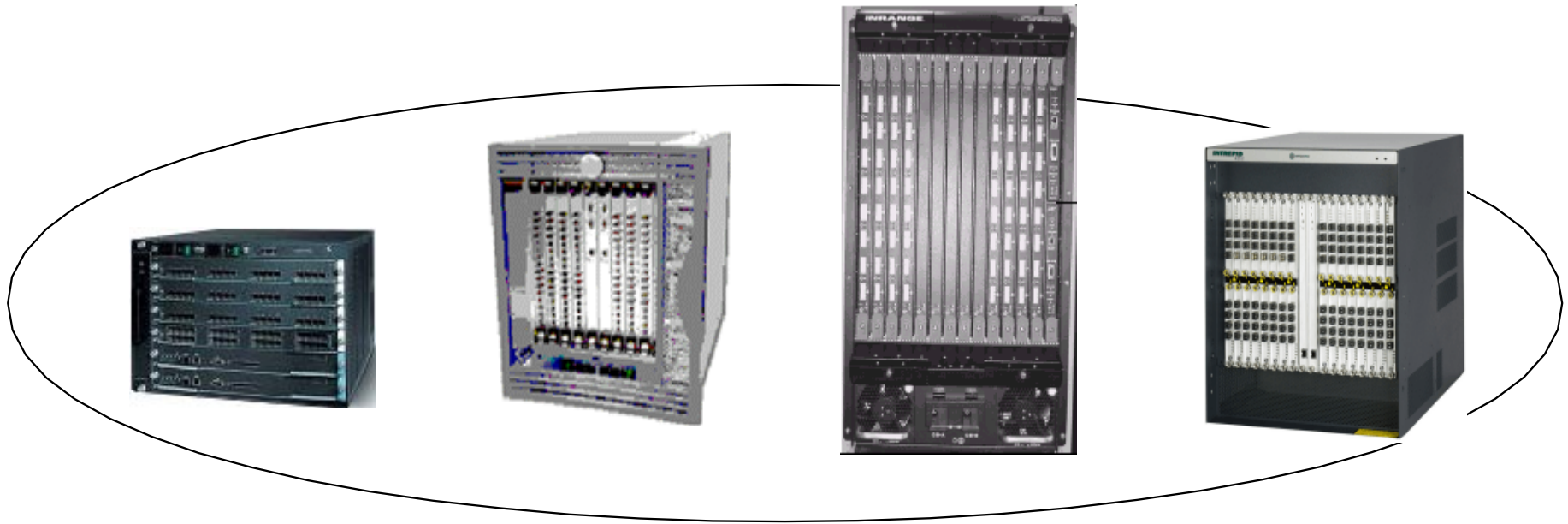

Director class FCS switches

Multiplatform FCS Connectivity

Enterprise Systems

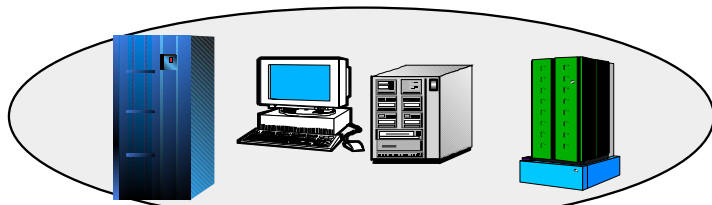

ESCON data rate 17MB

EMC

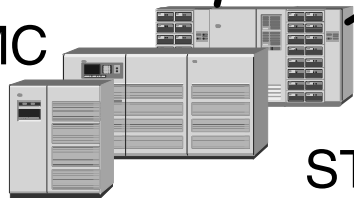

STK

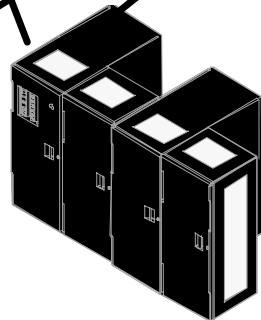

IBM



2105 ESS
DS6000/8000

- Mature environment
- FICON control units
- Storage shared OS/390 only

Open Systems

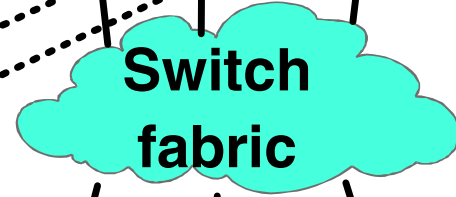
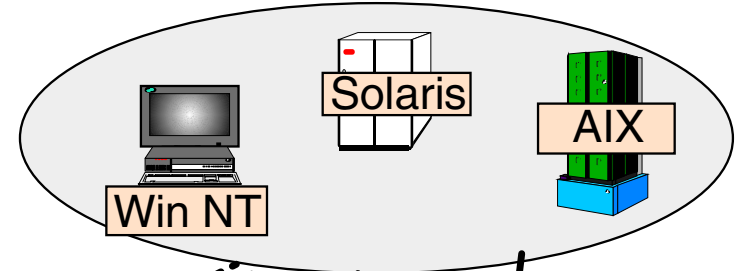

More control units accepting FCS

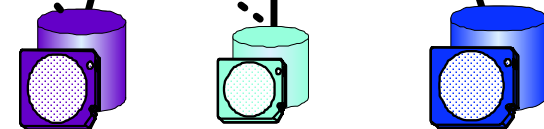

- Explosive growth
- Storage consolidation
- Fibre Channel Standard

FICON Environment Opportunity

- FICON environment may promote (force) Enterprise and Open system communication
- FICON switches use FCS - allows intermixing with open systems
 - Who will own?
 - How will it be configured?
 - Where and how will the documentation be maintained?
 - Is terminology understood?
 - Logical ports, physical ports, port zoning/soft zoning
- Enterprise Systems must have some knowledge of the Open Systems world
- Open Systems world must have some knowledge of the Enterprise world

FICON And FCS Terminology

- FICON uses Fibre Channel Standard (FCS)
- FCS terminology is typically understood in the Open Systems SAN Environment
- FCS terminology is typically *NOT* understood in the large mainframe environment
- FCS terminology uses acronyms and terms such as:
 - N_Port, F_Port, E_Port, NL_Port
 - WWN, WWNN, WWPN
 - ISL, Fabric
 - Cascaded switches and noncascaded switches
- These terms should be understood because they will be used more and more in the mainframe environment

Fibre Channel Terminology

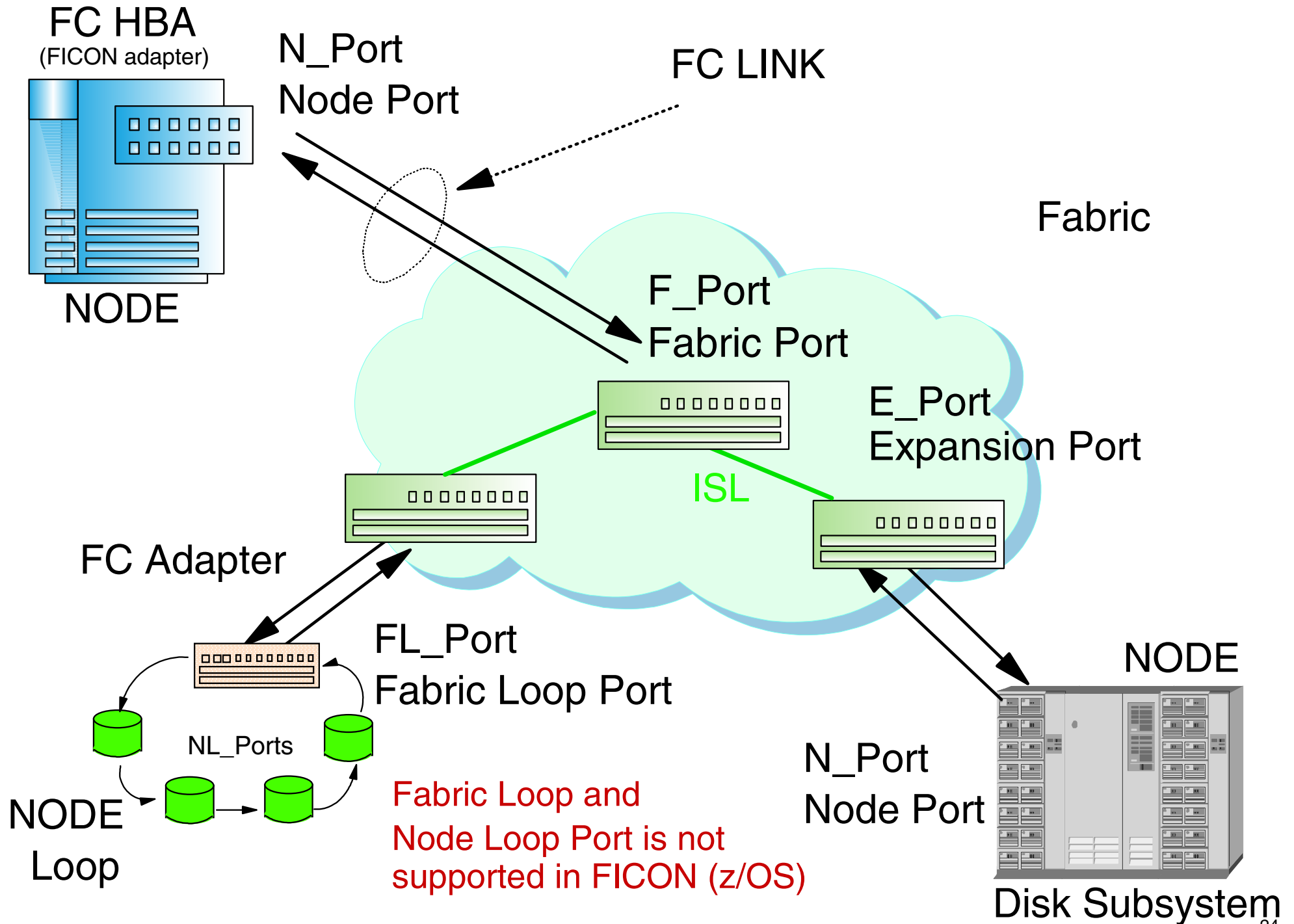

World Wide Names (WWN)

- The WWN is a globally unique name registered with the IEEE
- A port within a node has its own port WWN and port address

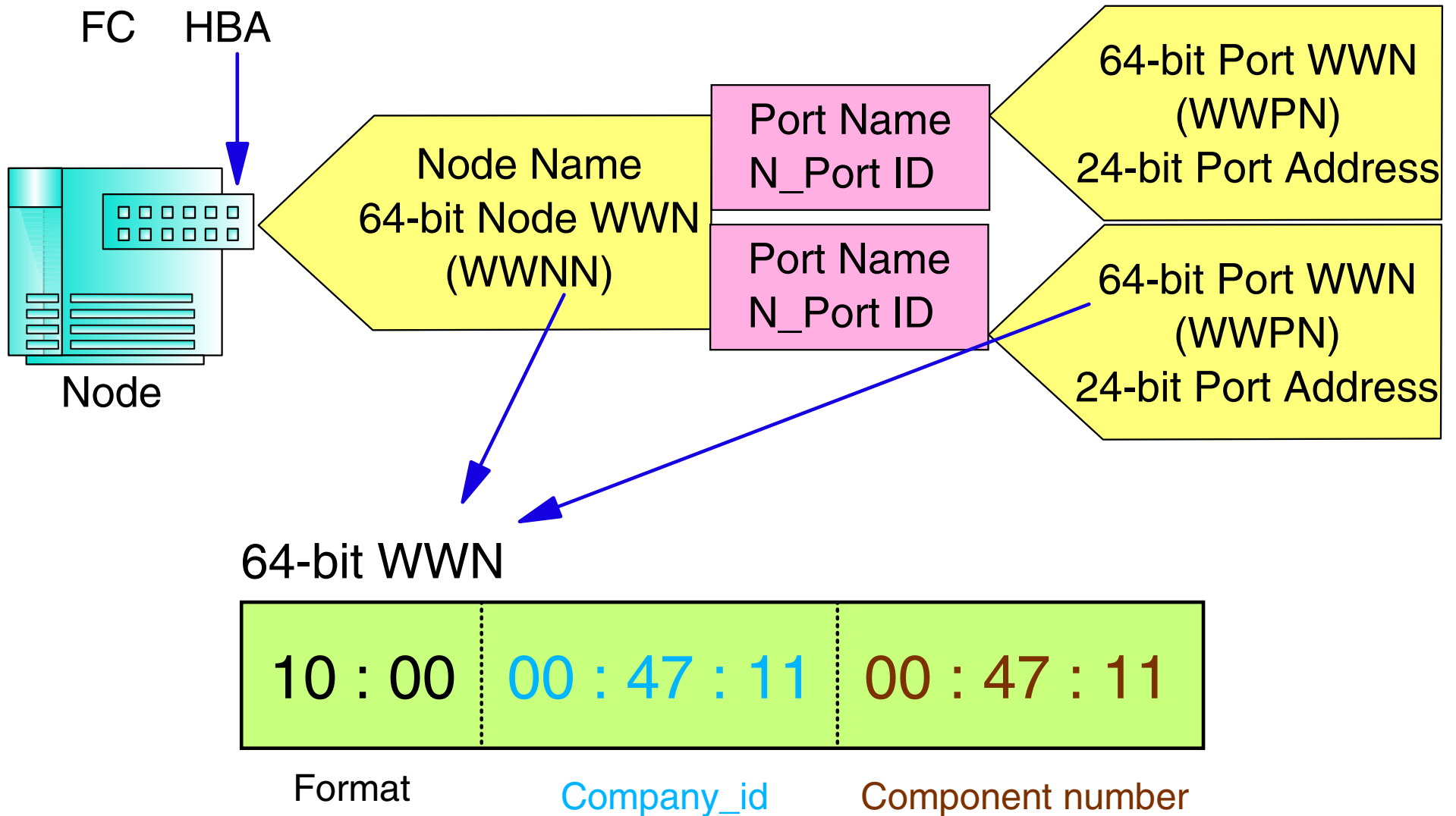

FICON's Use of WWNs

- To participate in the Fibre Channel environment, each node is assigned a unique 64-bit node WWN or World Wide Node Name (WWNN).
- Each Port within the node contains a 64-bit port name called a World Wide Port Name (WWPN)
- WWNs provide a mechanism to uniquely identify every node and every port within a node in the SAN fabric
- The SAN Fabric can be considered as the collection of one or more interconnected switches that provide Fibre Channel services
- WWNNs and WWPNs are returned when doing Fabric Logins (FLOGI) and Port Logins (PLOGI), which is part of the FCS protocol
- FICON uses FCS FLOGI / PLOGI and therefore require the use of WWNs

What Is a Fabric?

The Fibre Channel architecture defines a set of services unique to networking in the Fibre Channel environment.

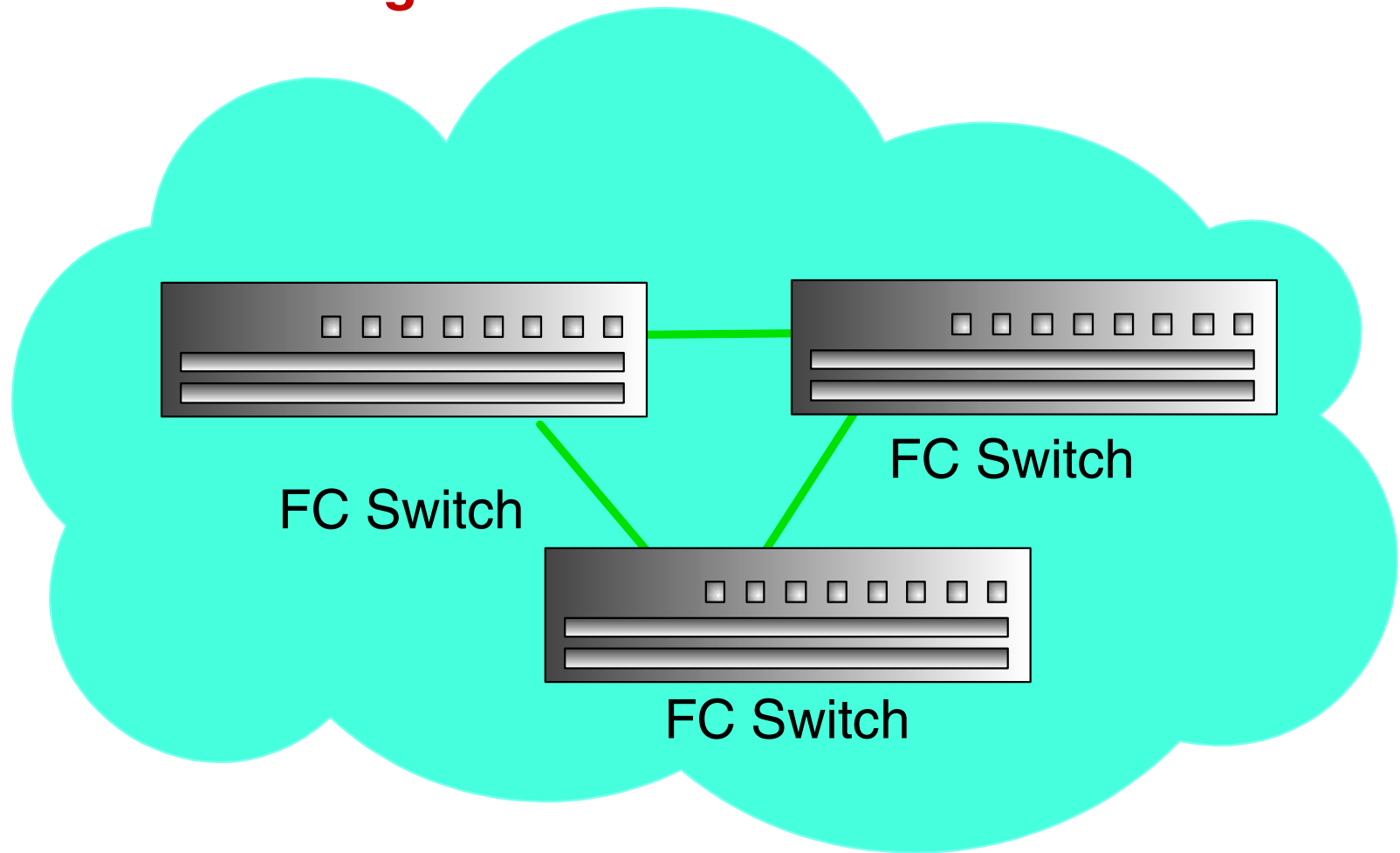

Interconnected switches providing Fibre Channel services such as login, routing, management type services and Name services for correlation of port addresses to WWNs.

Switched Fabric (Non-Cascaded)

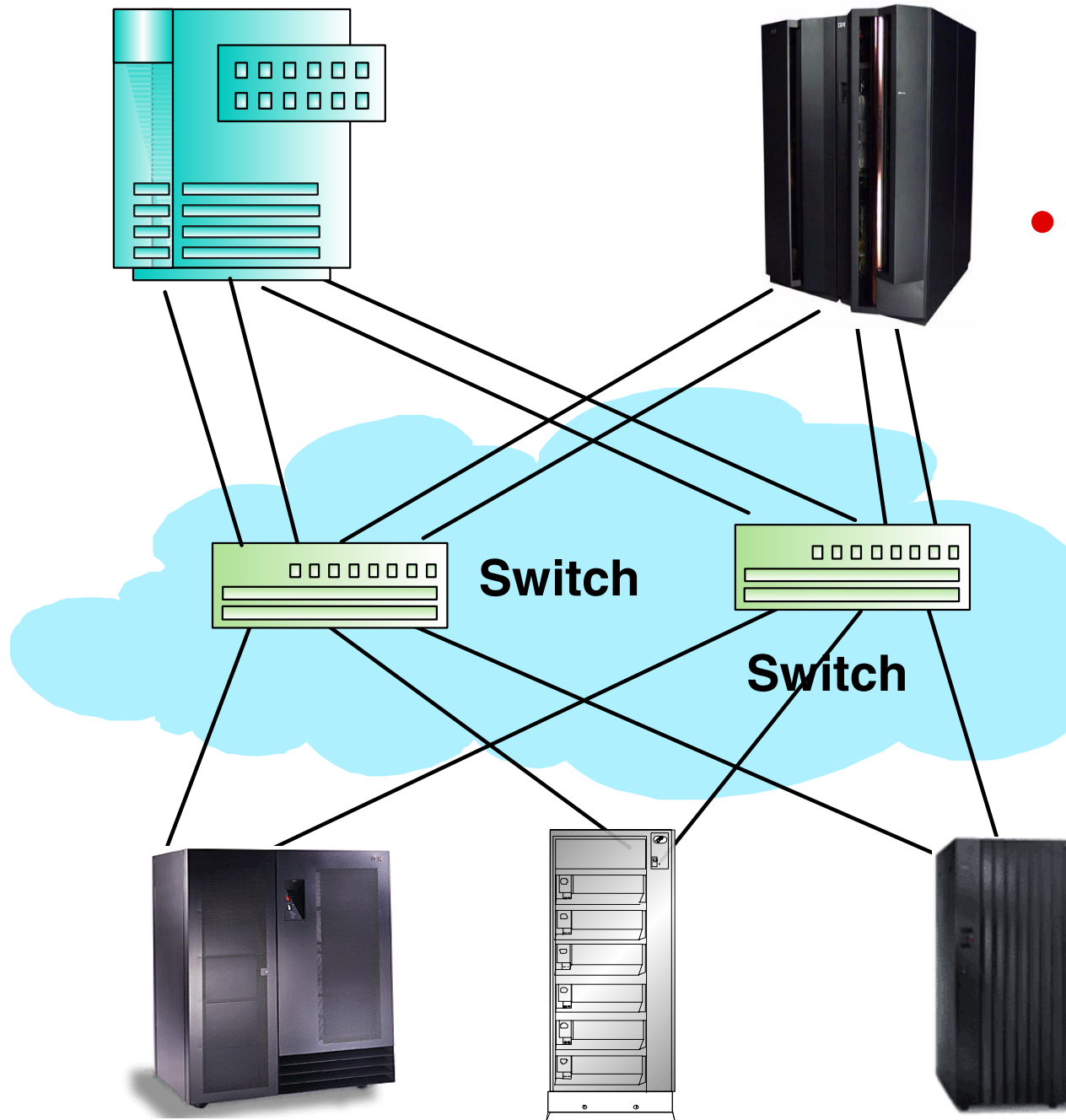

- Non-Cascaded fabrics can be directly related to both FCS and ESCON configurations

- Switches are not interconnected

Switched Fabric (Cascaded)

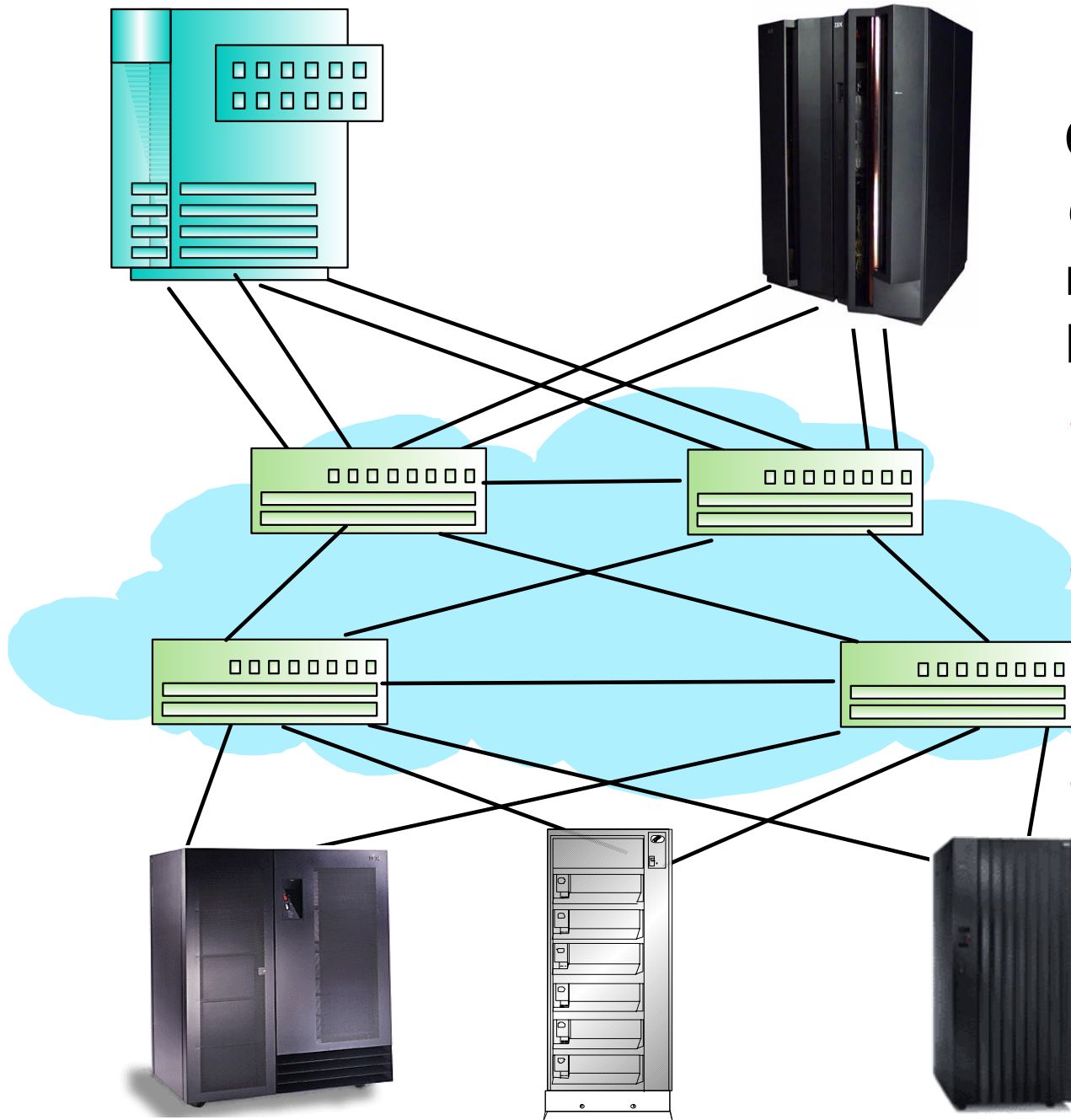

Cascaded fabrics

CANNOT be directly related to both FCS and ESCON configurations

- FCS switches do not dedicate connections
- z/OS (FC) supports one hop (two switches) to target CU
- ESCON - Up to two switches, one must have a dedicated connection = *Chained*

ESCON (fabric) Supported Configurations

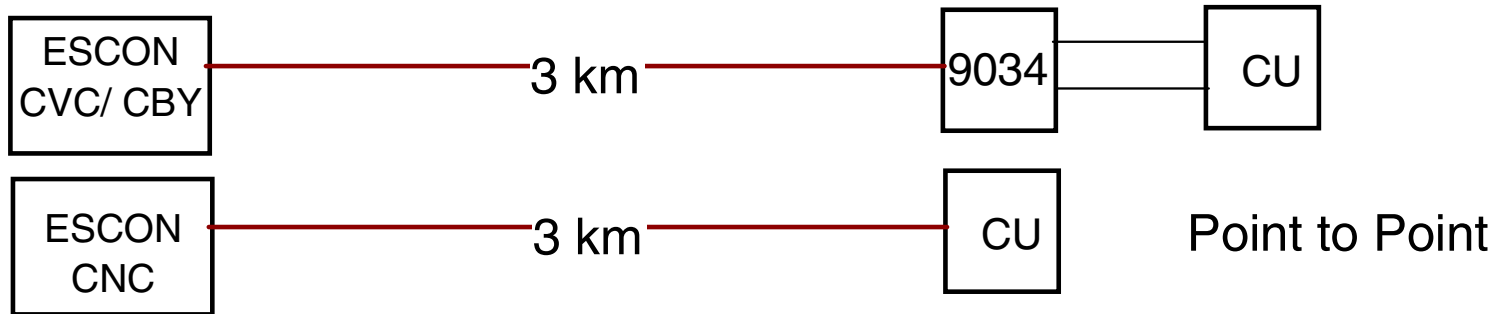

LED = 3km LED is Multimode Fiber

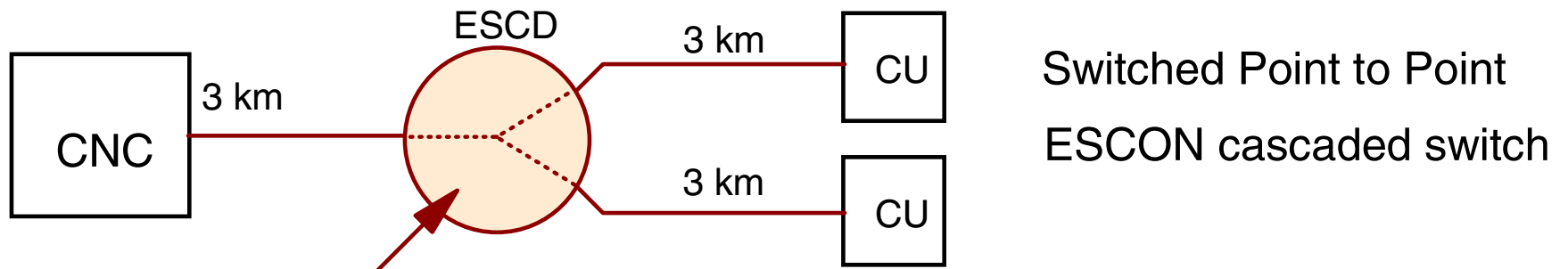

Dynamic

XDF = 20km XDF is Single Mode Fiber

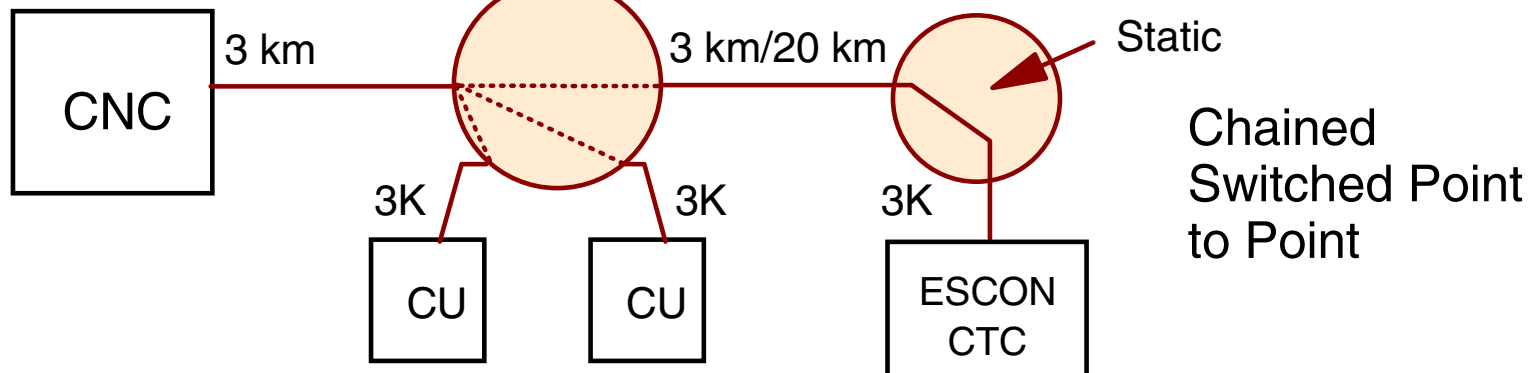

Four Generations of FICON

- **FICON Express and Express2 Feature**

- 2 Gb link capability

- **FICON Feature**

- 1 Gb link capability

- **Minimum of zero, maximum of 84 features** (z9 up to 336 FICON channels)

- 9672 one channel
- zSeries two or four channels each
- System z9 four channels each
- zSeries 900 FICON or FICON Express
 - FICON Express after 10/30/2001
- z800 FICON Express only
- z890/z990 FICON Express or Express2
- System z9 FICON Express2 only

- **Supports up to three types of channels**

- FICON Bridge FCV Mode
- Native FICON FC Mode
 - Also supports CTC
- FCP Channel FCP Mode
 - Fibre Channel Protocol for SCSI, Linux® only

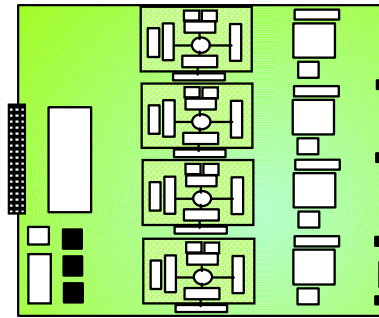

4th Generation FICON
FICON Express2 (2Gb)
4 channels per card

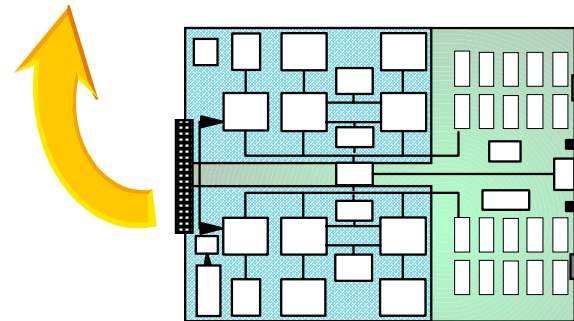

LC Duplex MM

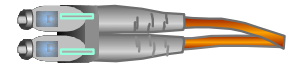

LC Duplex SM



2-channel FICON Express Card (2 Gb)

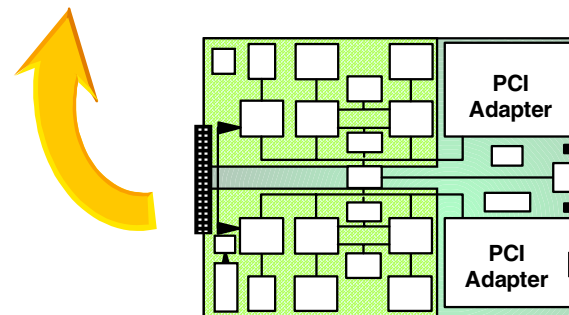

SC Duplex SM

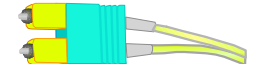

SC Duplex MM



2-channel FICON Card (1 Gb)

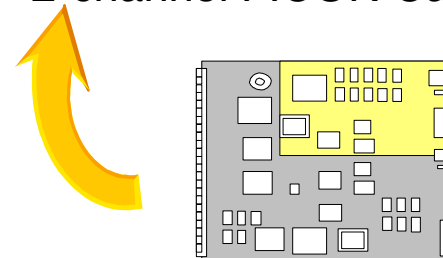

1st Generation FICON
9672 G5/G6
1-channel (1 Gb)

FICON Channel Options (LX - SX)

- Two types of FICON channels may be ordered
 - FICON long-wave (LX)
 - FICON short-wave (SX)
- FICON LX
 - 9 um single mode cable
 - supports a distance of 10 km (12 or 20 km with RPQ)
 - Channel TYPE = (FC) or *(FCV) in HCD
- FICON SX
 - 50 um multimode cable and supports up to 500 meters
 - 62.5 um multimode cable and supports up to 300 meters
 - Channel TYPE = FC in HCD
- FOSA technology must match at each end of FC link
 - FICON LX to Control unit LX
 - FICON SX to Control unit SX

* FCV attaches to bridge card, bridge cards are available in long wave only

FICON Cabling

FICON, ESCON Fiber Infrastructure - co-existence

- 9-micron single mode optical fiber is supported for 10 km FICON LX Channel links (12 or 20 km with RPQ depending on data rate)
- 62.5 micron multimode optical fiber supported for 120 m (200 MB data rate) or 300 m (100 MB data rate) for FICON SX channel links
- 50 micron multimode optical fiber supported for 300 m (200 MB data rate) or 500 m (100 MB data rate) for FICON SX channel links
- Reuse of ESCON 62.5 and 50 micron MM fiber
 - FICON LX supported for 550 meters
 - Requires IBM mode conditioner patch cables - FC 0106 or FC 0103
(This is not supported for 200 MB data rate)
 - FCS SC duplex receptacles on FICON channel and control unit
 - FICON SX would require a conversion cable to change connector ends from ESCON duplex to FCS SC duplex

Fibre Optic Technology

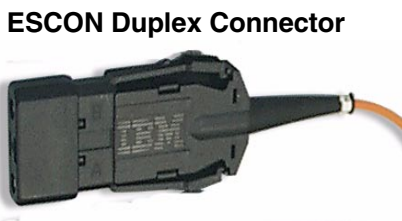
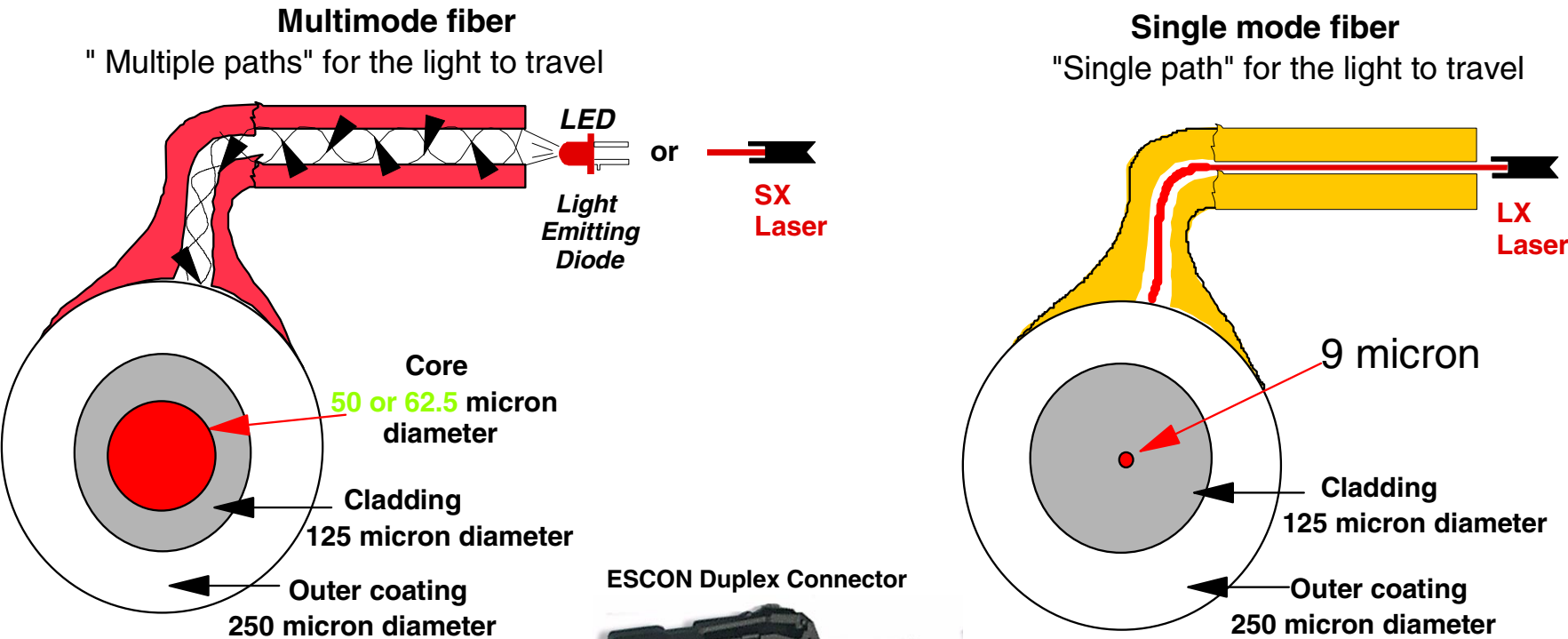

SC Duplex multimode

100 MB link

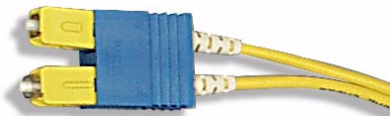

SC Duplex single mode

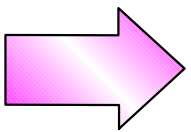

LC Duplex single mode

200 MB link

zSeries Educational Offerings

zSeries Operational and Technical Update course offerings

- **OZ96 (5) zSeries Channel Architecture, ESCON / FICON, Planning, Ops & PD**
- **ES326 (3) FICON(fc,fcv,fcv) Planning, Implementation, Operation & PD**
- **H4016 (2) HMC Class**
- **ES83 (5) CSAR (Complex Systems Availability & Recovery)**
- **ES82 (2) System z9 & zSeries Mainframe Environment (A Technical Overview)**
- **OZ09 (2) z/Architecture for z900 and z800**
- **OZ05 (2) z9 and z990/z890 Technical Update & Configuration Guidelines**
- **ES96 (4) HCD and Dynamic I/O**
- **ES27 (3) z/OS and OS/390 System Operations**