

# z/VSE News

Ingolf Salm

[salm@de.ibm.com](mailto:salm@de.ibm.com)

Ingolf's z/VSE Blog: <https://www.ibm.com/developerworks/mydeveloperworks/blogs/vse>

## Trademarks

The following are trademarks of the International Business Machines Corporation in the United States and/or other countries.

**IBM\***  
**IBM Logo\***

\* Registered trademarks of IBM Corporation

The following are trademarks or registered trademarks of other companies.

Adobe, the Adobe logo, PostScript, and the PostScript logo are either registered trademarks or trademarks of Adobe Systems Incorporated in the United States, and/or other countries.  
Cell Broadband Engine is a trademark of Sony Computer Entertainment, Inc. in the United States, other countries, or both and is used under license therefrom.  
Java and all Java-based trademarks are trademarks of Sun Microsystems, Inc. in the United States, other countries, or both.  
Microsoft, Windows, Windows NT, and the Windows logo are trademarks of Microsoft Corporation in the United States, other countries, or both.  
INFINIBAND, InfiniBand Trade Association and the INFINIBAND design marks are trademarks and/or service marks of the INFINIBAND Trade Association.  
Intel, Intel logo, Intel Inside, Intel Inside logo, Intel Centrino, Intel Centrino logo, Celeron, Intel Xeon, Intel SpeedStep, Itanium, and Pentium are trademarks or registered trademarks of Intel Corporation or its subsidiaries in the United States and other countries.  
UNIX is a registered trademark of The Open Group in the United States and other countries.  
Linux is a registered trademark of Linus Torvalds in the United States, other countries, or both.  
ITIL is a registered trademark, and a registered community trademark of the Office of Government Commerce, and is registered in the U.S. Patent and Trademark Office.  
IT Infrastructure Library is a registered trademark of the Central Computer and Telecommunications Agency, which is now part of the Office of Government Commerce.

\* All other products may be trademarks or registered trademarks of their respective companies.

### Notes:

Performance is in Internal Throughput Rate (ITR) ratio based on measurements and projections using standard IBM benchmarks in a controlled environment. The actual throughput that any user will experience will vary depending upon considerations such as the amount of multiprogramming in the user's job stream, the I/O configuration, the storage configuration, and the workload processed. Therefore, no assurance can be given that an individual user will achieve throughput improvements equivalent to the performance ratios stated here.  
IBM hardware products are manufactured from new parts, or new and serviceable used parts. Regardless, our warranty terms apply.  
All customer examples cited or described in this presentation are presented as illustrations of the manner in which some customers have used IBM products and the results they may have achieved. Actual environmental costs and performance characteristics will vary depending on individual customer configurations and conditions.  
This publication was produced in the United States. IBM may not offer the products, services or features discussed in this document in other countries, and the information may be subject to change without notice. Consult your local IBM business contact for information on the product or services available in your area.  
All statements regarding IBM's future direction and intent are subject to change or withdrawal without notice, and represent goals and objectives only.  
Information about non-IBM products is obtained from the manufacturers of those products or their published announcements. IBM has not tested those products and cannot confirm the performance, compatibility, or any other claims related to non-IBM products. Questions on the capabilities of non-IBM products should be addressed to the suppliers of those products.  
Prices subject to change without notice. Contact your IBM representative or Business Partner for the most current pricing in your geography.

## *Agenda*

- Roadmap
- z/VSE 5.1 key functions
- z/VSE 5.1 additional enhancements
- CICS Explorer
- z/VSE 5.1.2

## VSE Roadmap

Quality

Connectivity

z/OS Affinity

Capacity

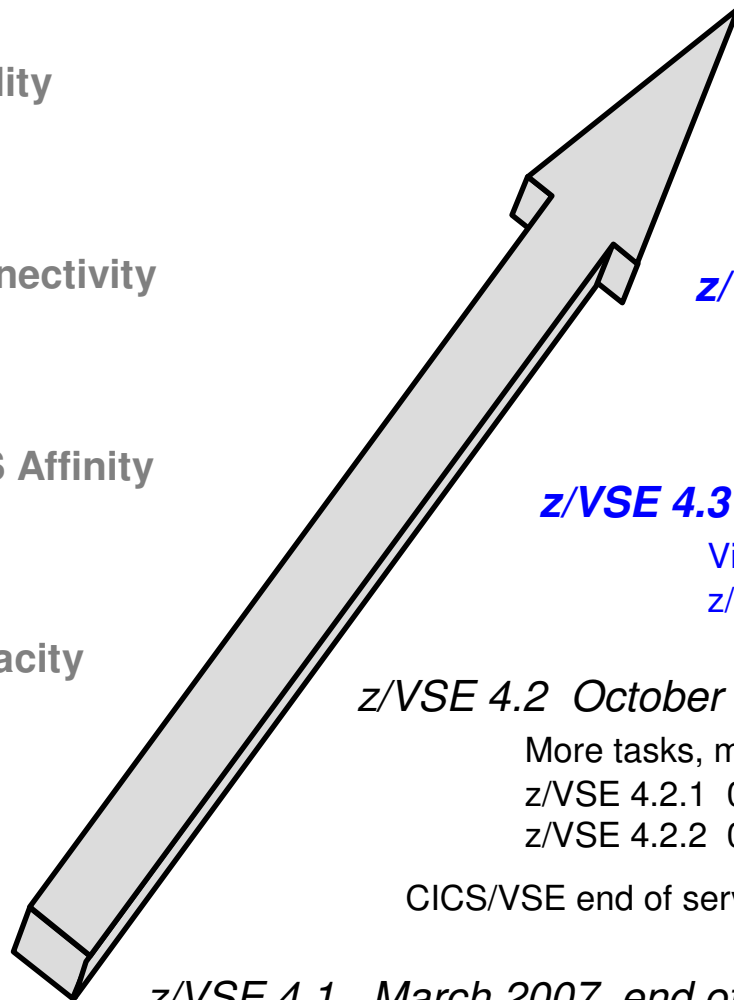

### **z/VSE Statement of Direction (SOD)**

Install from DVD  
CICS Explorer update

### **z/VSE 5.1.1 (+ Enhancements) GA 06/14/2013**

TS1140, 64 bit I/O, openssl and  
database connector enhancements

### **z/VSE 5.1 GA 11/25/2011**

64 bit virtual, zEnterprise exploitation, z9 or higher  
z/VSE 5.1.1 06/2012: CICS Explorer, LFP in LPAR,  
database connector

### **z/VSE 4.3 11/2010, end of service 05/31/2014**

Virtual storage constraint relief, 4 digit cuus  
z/VSE 4.3.1 08/2011

### **z/VSE 4.2 October 2008, end of service 10/31/2012**

More tasks, more memory, EF for z/VSE 1.1, CPU balancing, SCRT on z/VSE  
z/VSE 4.2.1 07/2009 - PAV, EF for z/VSE 1.2  
z/VSE 4.2.2 04/2010 - IPv6/VSE 05/2010

CICS/VSE end of service 10/31/2012

### **z/VSE 4.1 March 2007, end of service 04/30/2011**

z/Architecture only, 64 bit real addressing, MWLC – full and sub-capacity pricing

## VSE Strategy

- Helps **Protect** your existing investments in core VSE programs, data, equipment, IT skills, *plus* business processes, end user training, etc.
  - modernize, i.e. extend VSE resources to Web
  - exploit IBM servers, storage, and software
  
- **Integrate** VSE with the rest of your IT based on open and industry standards
  - (IBM) middleware
  - VSE connectors and web services
  
- **Extend** with Linux on System z
  - infrastructure consolidation/simplification
  - add new infrastructure and/or line-of-business applications

## Why Not Think Inside the Box?

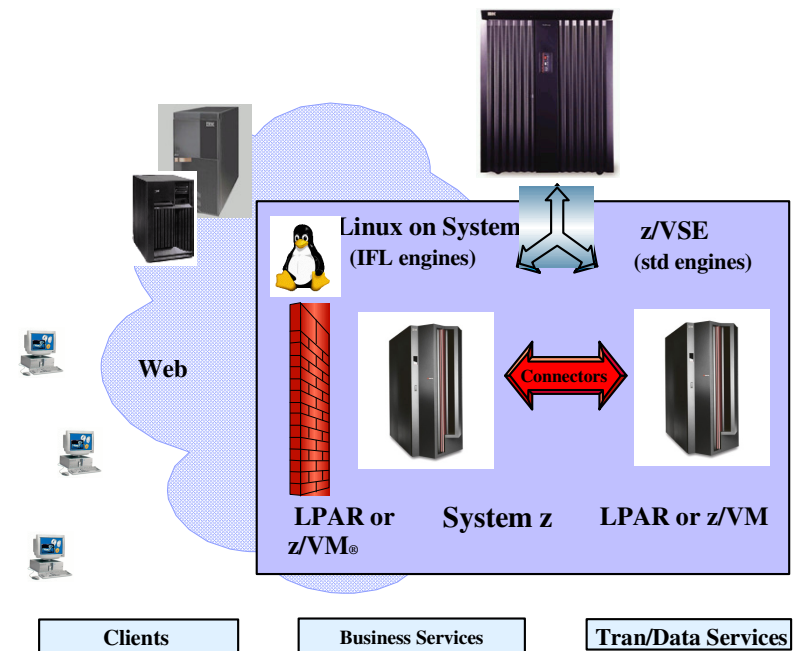

## *z/VSE V5.1*

- z/VSE 5.1: Preview 04/12/2011, Announcement 10/12/2011, GA 11/25/2011
- z/VSE 5.1.1: GA 06/15/2012, z/VSE 5.1.2: GA 06/14/2013
  
- 64-bit virtual addressing
  
- Introduces Architectural Level Set (ALS) that requires System z9 or later
  
- IBM zEnterprise support (z196, z114, zEC12, zBC12)
  - Support Static Power Save Mode for MWLC clients with subcapacity option (z196, zEC12 only)
  - 4096-bit RSA keys with Crypto Express3 for enhanced security
  - Support of OSA-Express for zBX (CHPID OSX) to participate in an Intra Ensemble Data Network (IEDN) in z/VM guest or LPAR
  
- Exploitation of IBM System Storage options
  - Copy Export function of TS7700 Virtualization Engine for disaster recovery
  - Multi-Cluster Grid support of the TS7700 Virtualization Engine Series (TS7700)
  - IBM Storwize V7000 Midrange Disk System (z/VSE 4.2 and later)
  - IBM XIV (z/VSE 4.2 and later)
  
- Fast Service Upgrade (FSU) from z/VSE 4.2 and z/VSE 4.3
  
- Pricing
  - Midrange Workload License Charge (MWLC) pricing with sub-capacity option
  - z114: Advanced Entry Workload License Charge (AEWLC) pricing with sub-capacity option

## *z/VSE V5.1*

- Networking enhancements
  - IPv6 support for Linux Fast Path
  - z/VSE z/VM IP Assist (VIA) exploitation
  - TCP/IP communication using Layer 2 (Data Link Layer)
  - Virtual Local Area Network (VLAN) support for OSA Express and Hipersockets
    - Global VLAN supported by TCP/IP for VSE/ESA and IPv6/VSE
    - General VLAN supported by IPv6/VSE
- IPv6/VSE
  - Large TCP window support, can increase throughput
  - 64 bit virtual exploitation, large TCP window storage allocated above the bar
  - Layer 2 support (OSA Express, IPv6 only)
  - VLAN support
- System management enhancements
  - SNMP Trap Client Extension monitoring – API
- High availability and disaster recovery enhancements
  - Copy Export function of TS7700 Virtualization Engine for disaster recovery
  - Multi-Cluster Grid support of the TS7700 Virtualization Engine Series (TS7700)
  - GDPS (Geographically Dispersed Parallel Sysplex) client (in a z/VM guest)
    - z/VSE supports heartbeat only
    - GDPS K-system can only monitor z/VSE
    - GDPS K-system can manage z/VM and therefore can manage z/VSE indirectly

## *z/VSE V5.1 ...*

- System enhancements

- Language Environment enhancements

- PL/I multitasking enhancements
    - C run-time socket API to include IPv6 related functions
    - Callable service sample for programs
    - Additions to system programmer C samples
    - Updated LE/C support for Librarian Members, and updates to the CEETRACE utility.

- E-business connector enhancements

- VSE Script Connector to support LIBR access

- VSE/POWER

- Token as new job attribute to address spooled output

- VTAPE enhancements

- VTAPE Auto Close at EOJ dependent on new SCOPE keyword
      - SCOPE= SYSTEM or JOB

- TAPE UNLOAD at EOJ (TAPE UNL=EOJ)



## *z/VSE 5.1 Additional Enhancements 2012*

- IBM z/VSE V5.1 - Additional enhancements: Announced 04/03/2012, GA 06/15/2012
- CICS Explorer for z/VSE
- Linux Fast Path in LPAR
- Linux Fast Path via z/VSE z/VM IP Assist (z/VSE VIA)
- z/VSE database connector
- VSE/POWER enhancement to ease job output handling (IPWSEGM to generate duplicates)
- IBM System Storage Tape Controller 3592 Model C07
- New symbolic parameter IJBVMID containing the z/VM userid if running on z/VM)
- PTFs: GA 11/2012
  - 64-bit input/output (I/O) processing for applications
  - IPv6/VSE V1.1 enhancements
    - Secure Sockets Layer (SSL) for secure data transmission
    - Layer 2 support for OSA Express devices for IPv4 links

## *IBM zEnterprise exploitation*

- 64 bit real addressing - up to 32 GB (System z)
- 64 bit virtual virtual addressing – up to 90 GB (System z)
  
- Large page support (z10, zEnterprise)
- Dynamic add / remove of logical CPs (z10, zEnterprise)
  
- Linux Fast Path (LFP) in z/VM mode LPAR (z10, zEnterprise)
- Exploitation of the z/VSE z/VM IP Assist (zEnterprise)
  
- 4096-bit RSA key support with configurable Crypto Express3 (z10, zEnterprise)  
.... and Crypto Express4S (zEC12, zBC12) – z/VSE 5.1 only
  
- zEnterprise and zEnterprise BladeCenter Extension (zBX) support
  - “native” Intra Ensemble Data Network (IEDN)
  - Virtual LAN support
  - Layer 2 support
  - IEDN communication using the z/VM VSWITCH
  
- HiperSockets Completion Queue on z196, z114, zEC12 (z/VSE 5.1.1)
  
- Static power save mode supported for SCRT (z196, zEC12)
  
- zEC12 / zBC12 does not support ESCON channels

## VSE Support for System z

VSE Release	z800 / z900	z890 / z990	System z9 / z10 / z196 / z114 / zEC12	VSE EoS
z/VSE V5.1	No	No	Yes	tbd
z/VSE V4.3	Yes	Yes	Yes	05/31/2014
z/VSE V4.2	Yes	Yes	Yes	10/31/2012
z/VSE V4.1	Yes	Yes	Yes	04/30/2011
z/VSE V3.1	Yes	Yes	Yes	07/31/2009
VSE/ESA V2.7	Yes	Yes	Yes	02/28/2007
VSE/ESA V2.6	Yes	Yes	Yes	03/2006
VSE/ESA V2.5	Yes	No	No	12/2003
VSE/ESA V2.4	Yes	No	No	06/2002
VSE/ESA V2.3	No	No	No	12/2001

## *Encryption Facility for z/VSE*

- Optional priced feature for VSE Central Functions
- Supports the use of SAM files, VSE/VSAM files, VSE library members, tapes, virtual tapes as input or output
- Requires CP Assist for Cryptographic Function (CPACF)
  - no charge feature, only on z890, z990, z9, z10, z114, z196, zEC12, zBC12 servers
- Extends affinity between z/VSE and z/OS
  - Function roughly equivalent to EF for z/OS 1.1
  - Compatible with EF for z/OS V1.1 (Encryption Facility System z format)
    - EF for z/VSE tapes can be read by EF for z/VSE, EF for z/OS, EF for z/OS Java Client, and Decryption Client for z/OS,
    - EF for z/OS V1.1 and EF for z/OS Java client tapes can be read by EF for z/VSE
- EF for z/VSE 1.2
  - Supports z/VSE 4.2 and later
  - Supports openPGP standard
  - OpenPGP exploits 4096-bit RSA keys (z10, zEnterprise)

## *TCP/IP Connectivity for z/VSE*

- TCP/IP connectivity for IPv4 communication
  - TCP/IP for VSE/ESA 1.5 – licensed from CSI International
  - IPv6/VSE – licensed from Barnard Software, Inc. (BSI)
  - Linux fast path (LFP)
  
  - EZA socket interface, new function calls
  - LE/C socket API
  
- TCP/IP connectivity for IPv6 communication
  - IPv6/VSE
  - Linux Fast Path (z/VSE 5.1)
  
  - EZA socket interface, new function calls
  
- All TCP/IP stacks can run concurrently within one z/VSE system

## *Linux Fast Path (LFP)*

- Routes IPv4 or IPv6 socket request to Linux on System z
  - Without using the local TCP/IP stack
- LFP on z/VM (z/VSE 4.3 or higher)
  - Uses an IUCV connection between z/VSE and Linux on System z
  - Both – z/VSE and Linux – need to be z/VM guests of the same z/VM
- Linux Fast Path using z/VSE z/VM IP Assist (VIA – z/VSE 5.1)
  - Both – z/VSE need to be a z/VM guests
- Linux Fast Path in LPAR (z/VSE 5.1 + enhancements – GA 06/15/2012)
  - LFP daemon on Linux forwards the socket request to the Linux TCP/IP stack
- LFP is transparent to IBM socket APIs
  - Supported APIs: LE/C socket API, EZA socket / EZASMI interface, ...
  - Transparent to IBM applications (DB2 client, Connectors, Power PNET)
  - No standard TCP/IP applications (Telnet, FTP, ...) provided
  - IPv6/VSE: TCP/IP applications can exploit LFP
- Provided with the z/VSE base product – no additional charge

## Linux Fast Path (LFP) - Linux Fast Path on z/VM

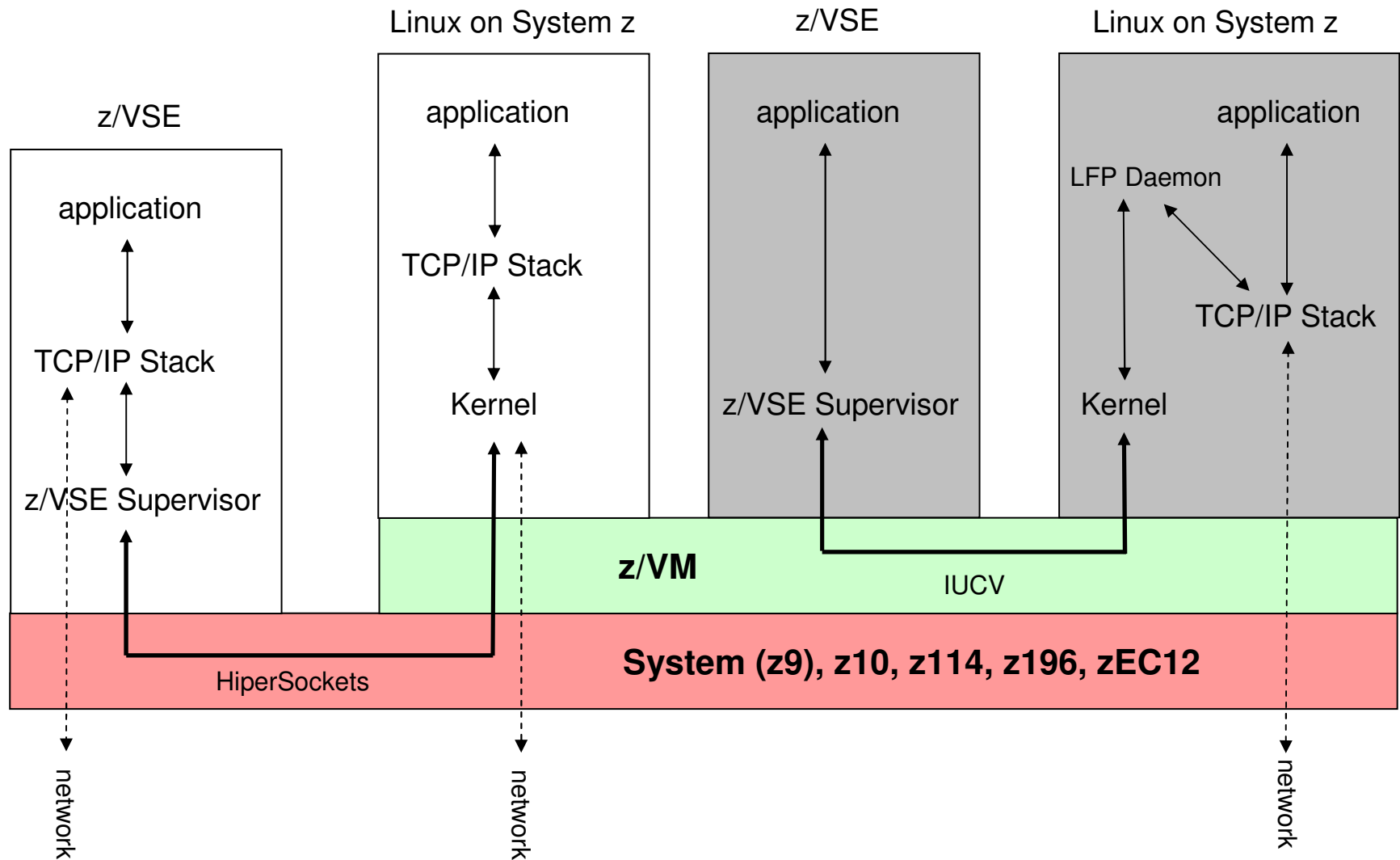

## LFP - z/VSE z/VM IP Assist (VIA) – z/VSE 5.1

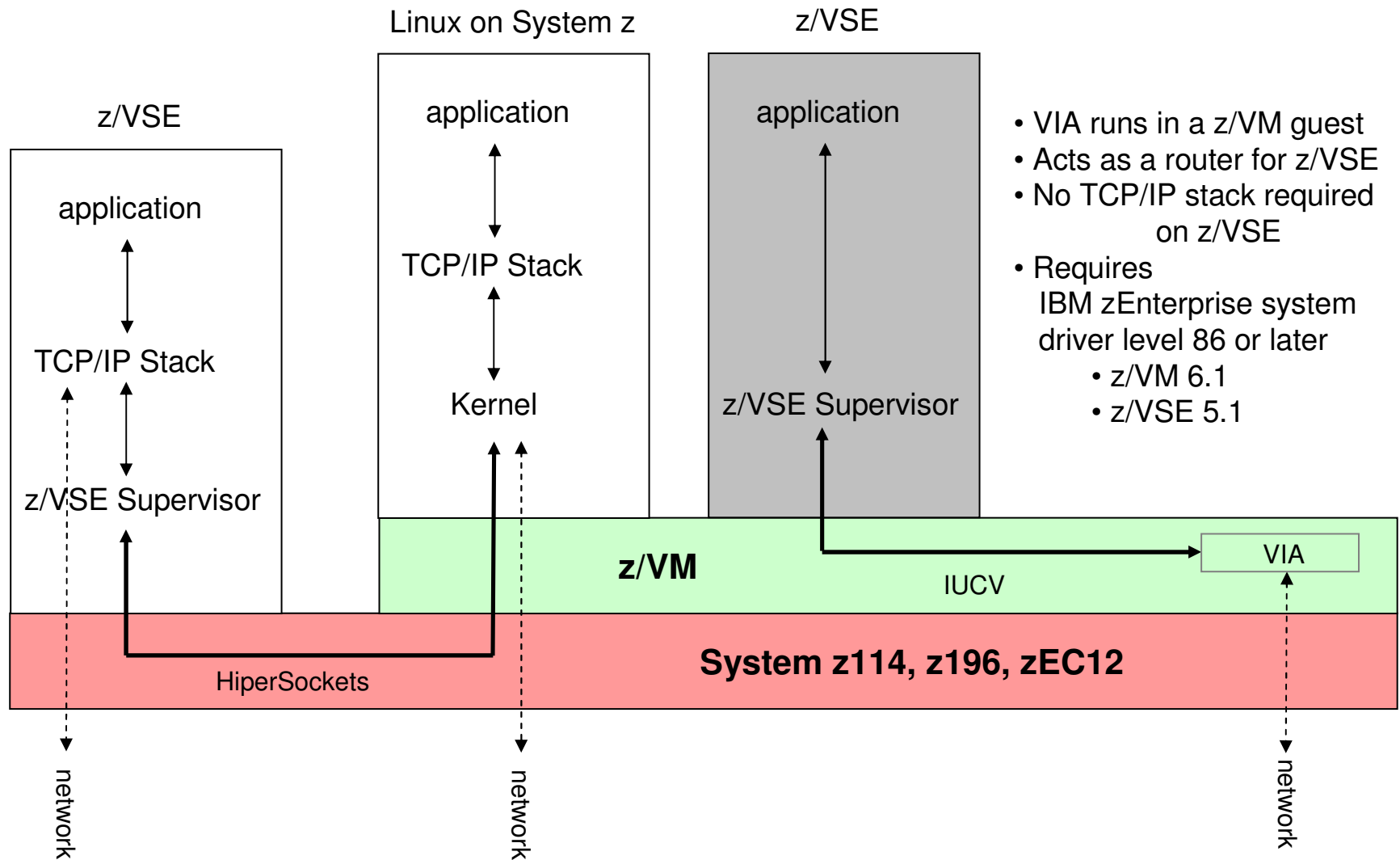



## Linux Fast Path (LFP) – Linux Fast Path in LPAR

- No TCP/IP stack required on z/VSE
- System requirements
  - Supported on zEnterprise
    - Exploits HiperSockets completion queue
  - Linux on System z distribution (RHEL, SLES)
  - Available with z/VSE 5.1.1 (z/VSE 5.1 + PTF)

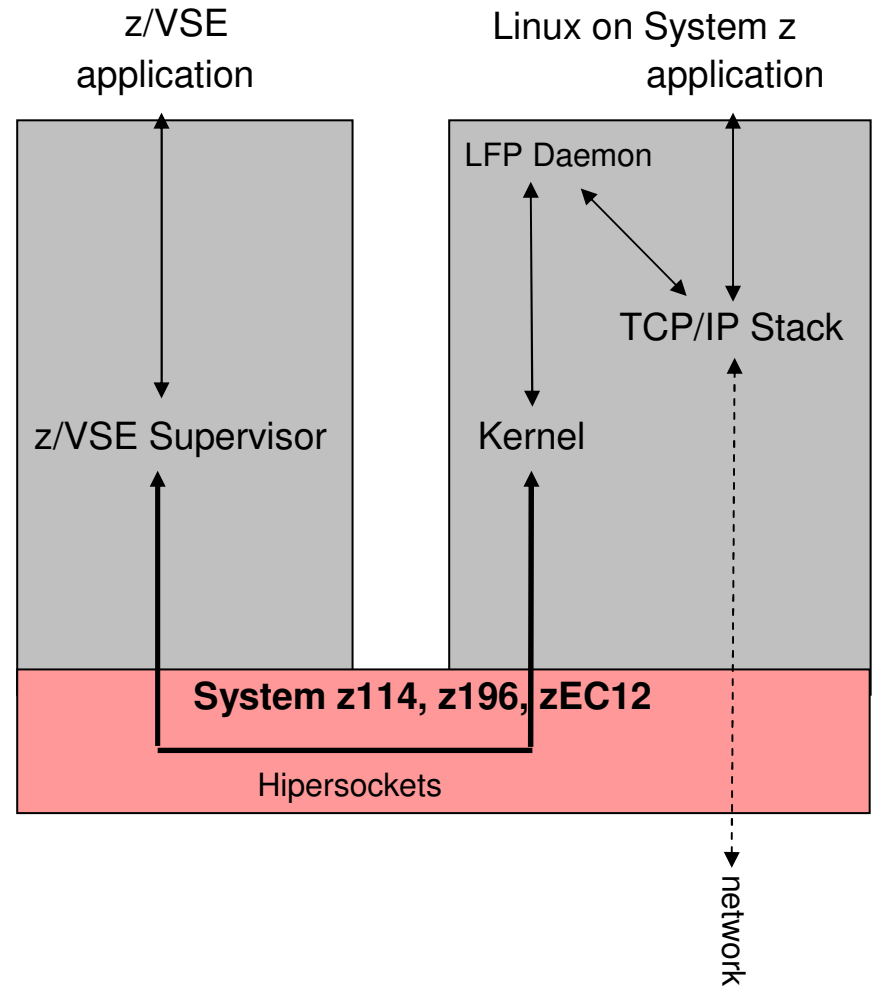

## Connectors

- SNMP Connector
  - SNMP (Simple Network Management Protocol) V1 protocol
  - Allows to monitor system events on a network
  - Clients can retrieve z/VSE specific system and performance data
  - Performance monitors may collect the data for planning purposes
  - **SNMP Trap Client Extension monitoring – API**

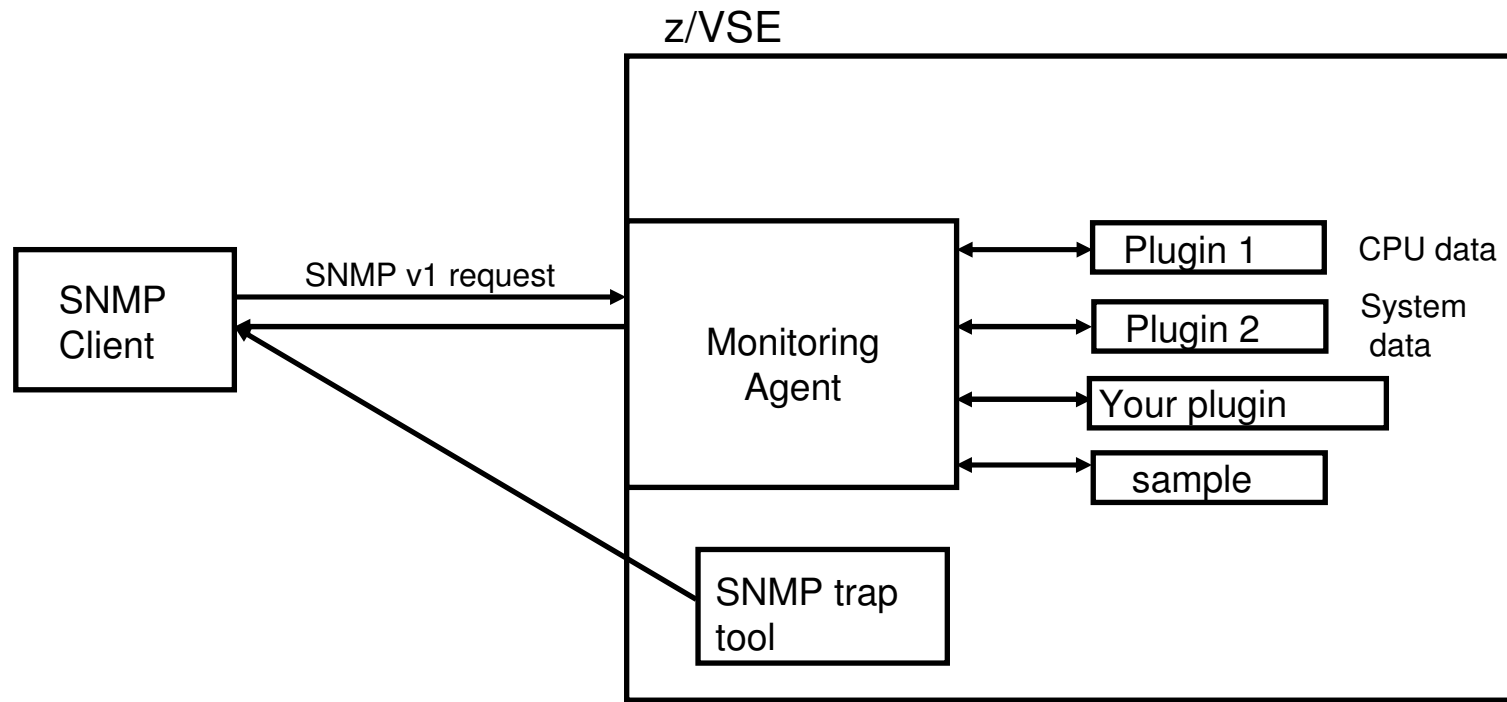

## Data Base Connector

- Available since June 15, 2012
- Provides a database call level interface (DBCLI)
  - For HLASM, COBOL, PL/I, C or REXX applications
- Connects to a remote database
- Consists of
  - DBCLI client on z/VSE
  - DBCLI server on any Java-capable platform

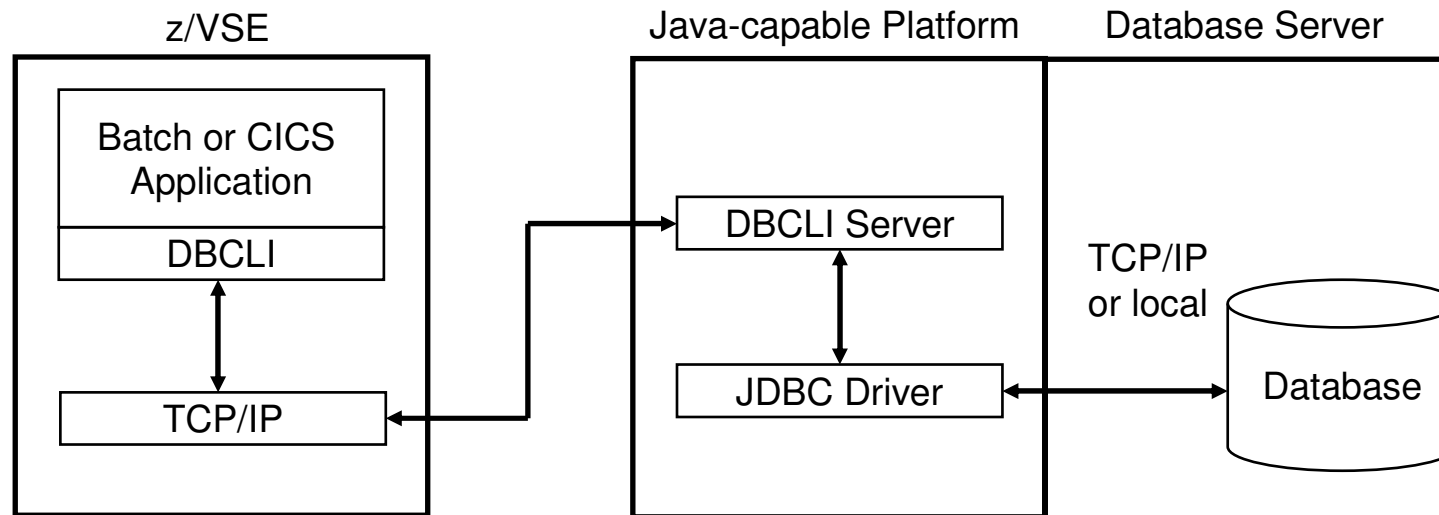

## *z/VSE 5.1: 64 bit virtual*

- Support 64 bit virtual addressing
- 64 bit area can be used for **data only**
  - No instruction execution above the bar
- **z/OS affinity:** APIs (IARV64 services) - to manage memory objects – compatible with z/OS
  - Private memory objects for use in one address space
  - Shared memory objects to be shared among multiple address spaces
- Maximum VSIZE still limited to 90 GB
- Advantages:
  - Eases the access of large amounts of data
    - E.g. instead of using and managing data spaces
  - Reduces complexity of programs
    - Data contained in primary address space
  - Chosen design has no dependencies to existing APIs, minor impact on existing system code

## *IARV64 Macro*

- IARV64 macro - ported from z/OS – provides services to
  - Creates and frees storage areas above the bar
  - Manage the physical frames behind the storage
  
- Programs use the IARV64 macro to obtain memory objects
  
- Services (IARV64 REQUEST=):
  - GETSTORE – create a private memory object
  - GETSHARED – create a memory object that can be shared across multiple address spaces
  - SHAREMEMOBJ – request that the specified address space be given access to a shared memory object
  - DETACH – free one or more memory objects
  - PAGEFIX – fix pages within one or more private memory objects
  - PAGEUNFIX – unfix pages within one or more private memory objects
  
  - GETSTORE / GETSHARED KEY parameter (default key = key of caller)
    - Unauthorized caller can set key 9 (all tasks can run in key 9)
    - Authorized callers can set any key

## 64 bit virtual - Address Space Layout

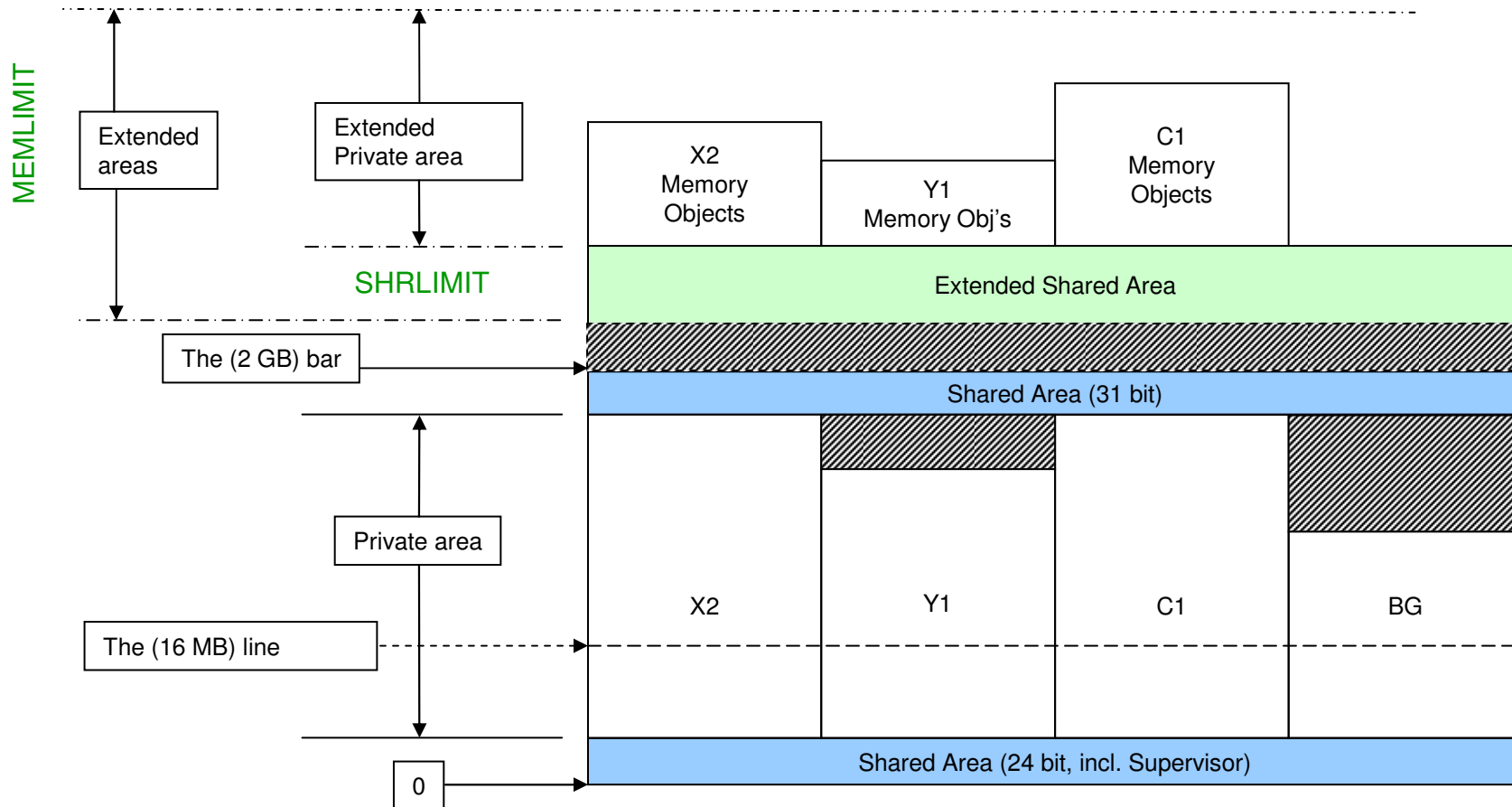

## *CICS Explorer for z/VSE*

- Announced 04/03/2012, GA 06/15/2012
  
- CICS Explorer – The new face to CICS
  - New system management framework for CICS TS
  - Consists of CICS Explorer client and a CICS TS server extension
  - CICS Explorer client
    - Read-only capabilities
    - Eclipse-based user interface on workstation
    - Connects to CICS TS via TCP/IP - Communication via HTTP requests
  - CICS Explorer server extension
    - Delivered as PTF for CICS TS for VSE/ESA 1.1.1
    - z/VSE 5.1 only

IBM CICS Explorer - C:/CICS-Work

File Edit Projekt Operations Definitions - Suchen Window Help

ISC/MRO Con TCP/IP Servic Terminals Programs Transactions TS Queues Transaction Cl Tasks Files TD Queues

CNX0211I Context: PRODCICS. Resource: PROGRAM. 1.603 records collected at 28.09.2012 18:04:08

Region	Name	Status	Use Count	Concurrent Us...	Language	Share Status	CEDF Status	NEWCOPY Status
PRODCICS	\$EDTCPM	✓ ENABLED	0	0	C	N/A	CEDF	NOTREQUIRED
PRODCICS	\$EDTCPV	✓ ENABLED	0	0	C	N/A	CEDF	NOTREQUIRED
PRODCICS	ARXITCPU	✓ ENABLED	0	0	ASSEMBLER	N/A	CEDF	NOTREQUIRED
PRODCICS	BSTADMII	✓ ENABLED	0	0	ASSEMBLER	N/A	CEDF	NOTREQUIRED
PRODCICS	CEEBINT	✓ ENABLED	1	1	ASSEMBLER	N/A	CEDF	NOTREQUIRED
PRODCICS	CEEBNATX	✓ ENABLED	0	0	ASSEMBLER	N/A	CEDF	NOTREQUIRED
PRODCICS	CEECBLDY	✓ ENABLED	0	0	ASSEMBLER	N/A	CEDF	NOTREQUIRED
PRODCICS	CEECCICS	✓ ENABLED	1	1	ASSEMBLER	N/A	CEDF	NOTREQUIRED
PRODCICS	CEECDATX	✓ ENABLED	0	0	ASSEMBLER	N/A	CEDF	NOTREQUIRED
PRODCICS	CEECMI	✓ ENABLED	0	0	ASSEMBLER	N/A	CEDF	NOTREQUIRED
PRODCICS	CEECOPT	✓ ENABLED	1	1	ASSEMBLER	N/A	CEDF	NOTREQUIRED
PRODCICS	CEECRHP	✓ ENABLED	0	0	ASSEMBLER	N/A	CEDF	NOTREQUIRED
PRODCICS	CEECXITA	✓ ENABLED	1	1	ASSEMBLER	N/A	CEDF	NOTREQUIRED
PRODCICS	CEECXTAN	✓ ENABLED	1	1	ASSEMBLER	N/A	CEDF	NOTREQUIRED
PRODCICS	CEECZST	✓ ENABLED	0	0	ASSEMBLER	N/A	CEDF	NOTREQUIRED
PRODCICS	CEEDATE	✓ ENABLED	0	0	ASSEMBLER	N/A	CEDF	NOTREQUIRED
PRODCICS	CEEDATM	✓ ENABLED	0	0	ASSEMBLER	N/A	CEDF	NOTREQUIRED
PRODCICS	CEEDAYS	✓ ENABLED	0	0	ASSEMBLER	N/A	CEDF	NOTREQUIRED
PRODCICS	CEEDCOD	✓ ENABLED	0	0	ASSEMBLER	N/A	CEDF	NOTREQUIRED
PRODCICS	CEEDSHP	✓ ENABLED	0	0	ASSEMBLER	N/A	CEDF	NOTREQUIRED
PRODCICS	CEEDYWK	✓ ENABLED	0	0	ASSEMBLER	N/A	CEDF	NOTREQUIRED
PRODCICS	CEEENV	✓ ENABLED	0	0	ASSEMBLER	N/A	CEDF	NOTREQUIRED
PRODCICS	CEEEV000	✓ ENABLED	0	0	NOTDEFINED	N/A	CEDF	REQUIRED
PRODCICS	CEEEV001	✓ ENABLED	0	0	NOTDEFINED	N/A	CEDF	REQUIRED
PRODCICS	CEEEV002	✓ ENABLED	0	0	NOTDEFINED	N/A	CEDF	REQUIRED
PRODCICS	CEEEV003	✓ ENABLED	1	1	ASSEMBLER	N/A	CEDF	NOTREQUIRED
PRODCICS	CEEEV004	✓ ENABLED	0	0	NOTDEFINED	N/A	CEDF	REQUIRED
PRODCICS	CEEEV005	✓ ENABLED	1	1	ASSEMBLER	N/A	CEDF	NOTREQUIRED
PRODCICS	CEEEV006	✓ ENABLED	0	0	NOTDEFINED	N/A	CEDF	REQUIRED
PRODCICS	CEEEV007	✓ ENABLED	0	0	NOTDEFINED	N/A	CEDF	REQUIRED
PRODCICS	CEEEV008	✓ ENABLED	0	0	NOTDEFINED	N/A	CEDF	REQUIRED
PRODCICS	CEEEV009	✓ ENABLED	0	0	NOTDEFINED	N/A	CEDF	REQUIRED
PRODCICS	CEEEV010	✓ ENABLED	1	1	ASSEMBLER	N/A	CEDF	NOTREQUIRED
PRODCICS	CEEEV011	✓ FNABLD	0	0	NOTDEFINED	N/A	CEDF	REQUIRED

IZE0100I Connected user SYSA to host l...m1.boeblingen.de.ibm.com on port 27283 | Inx



## *z/VSE 5.1.2*

- z/VSE 5.1.2 includes z/VSE V5.1 - Additional enhancements: Ann 03/02/2013, GA 06/14/2013
  - Support of zEC12, zBC12
    - Configurable Crypto Express4S
    - OSA Express4S / OSA Express5S (1000BASE-T)
  - Support of IBM System Storage
    - IBM System Storage TS1140 (3592 E07)
    - IBM System Storage TS7700 Virtualization Engine Release 3.0
    - IBM System Storage DS8870
    - IBM System Storage Storwize V7000 Release 6.4
  - 64-bit input/output (I/O) processing for applications
  - HiperSockets configurable input buffers
  
- z/VSE 5.1.2 – latest Recommended Service Level (RSL): June 18, 2013

## *z/VSE 5.1.2 ...*

- z/VSE 5.1.2 includes z/VSE V5.1 - Additional enhancements ...

- System dump support for memory objects
- z/VSE Database connector enhancements
- OpenSSL update
- IPv6/VSE V1.1 enhancements
  - o Secure Sockets Layer (SSL) for secure data transmission
  - o Layer 2 support for OSA Express devices for IPv4 links

– Statement of general direction (SOD) of April announcement:

- IBM intends
  - o in the future to enhance IBM CICS Explorer for IBM CICS Transaction Server for VSE/ESA to provide updates to CICS resources.
  - o to add functionality that allows initial installation of z/VSE without requiring a physical tape.

All statements regarding IBM's plans, directions, and intent are subject to change or withdrawal without notice.

## *64 bit virtual I/O for applications*

- Available with z/VSE 5.1 APAR DY47419
- SYSCOM bit IJBIO64E in IJBIOFL1, if 64 bit virtual I/O support available
  
- I/O buffers can now be created above the bar (above 2 GB)
- I/O buffers in **private memory objects** supported only
- I/O control blocks to be allocated below the bar (in 31 bit storage)
  
- Supported for ECKD devices
  
- CCB macro with a new parameter: IDAW=FORMAT2
- CCB points to a Format-0 or Format-1 CCW
- CCW with IDA-flag and data address point to a single Format-2 IDAW containing a 64 bit virtual address.
  
- I/O buffer will be TFIXed by I/O Supervisor, not necessary to PFIx the I/O buffer
  
- Not supported for
  - FBA / SCSI devices
  - Tape devices
  - LIOCS

## *System Dump support for Memory Objects*

- System dump may be taken in case of abnormal termination dependent on JCL options
  - New JCL option MODUMP, NOMODUMP
- If program running in 64 bit mode and registers hold 64 bit addresses
  - The dump routine will take 4K on either side of this address
- Memory object dumps are written to SYSLST only
  - Partitions dumps will be written to dump library or SYSLST dependent on OPTIONS
- New standard option: STDOPT SADMPSMO=YES|NO
  - Controls, if standalone dump should include **shared memory objects**
- (Standard) option STDOPT SADUMP=(n,m,o)
  - Controls, if standalone dump should include **private memory objects**

## *HiperSockets Configurable input buffers*

- Available as APAR DY47394
- QDIO input queue buffers were set to 8 before
- More QDIO input buffers can improve performance
- In z/VSE you may increase the number of buffers to up to 64
- With a new configuration option you may select 8 (default), 16, 32 or 64 in the configuration file (IJBONCONF.PHASE)
- QDIO input buffers are allocated in 31 bit partition GETVIS space
- The buffers are to be PFIxed.
  - The limit for PFIx storage has to be defined with the JCL SETPFIx command
- QDIO input buffers are available for HiperSockets and OSA Express (CHPID OSD)

## *OpenSSL Update*

- openssl support for z/VSE is available since z/VSE 5.1
- November 2012 updated with APAR DY47397
  
- openssl code level: openssl 1.0.0d
- z/VSE supports a subset of openssl functions
  
- IPv6/VSE and Linux Fast Path exploit openssl
  
- z/VSE supports the GSK (z/OS SSL API) and openssl API

## *z/VSE Database Connector (DBCLI) Enhancement*

- DBCLI connection pooling
  - Connection pooling of database connections for DBCLI applications on CICS TS
  - Pooling and reusing existing connection
    - Instead to establish a new connection
  - CICS DBCLI application can request to use a connection pool by setting a new DBCLI environment variable
  - SSL connections are not supported
  
- If connection pooling is enabled
  - CONNECT function will first check if a matching connection is available (same host name/IP address, port, DB name, user-ID, password, ...)
  - If available, the connection will be reused
  - If no active connection available, a new connection is established
  - During DISCONNECT the connection is put back to the connection pool

## *z/VSE Statement of Direction (SOD)*

- IBM CICS Explorer to provide updates to CICS resources
  - Update resources as you would do with transactions on your CICS terminal
  - Enable / disable CICS resources
  - Change selected CICS definitions
  - ....
  
- Initial installation of z/VSE without requiring a physical tape
  - Use an install image on a DVD or download it from the web (Shopz)
  - Create an installation disk
  - Base install z/VSE from installation disk



## *z/VSE 5.1 Migration Considerations*

- Migrate to z/VSE 5.1.2 + Recommended Service Level (RSL) of June 2013
- VSE/VSAM
  - Migration of VSAM catalogs
    - Don't use Fastcopy to migrate VSAM catalogs
    - Flashcopy all VSAM volumes allocated to a VSAM catalog
    - Migrate all recoverable VSAM catalogs to standard VSAM catalogs
      - o **Before** the migration to z/VSE 4.3 or z/VSE 5.1
      - o PTF for “automatic” migration
- CICS/VSE
  - CICS Coexistence Environment removed
  - DL/I 1.12 replaces DL/I VSE 1.11 and DL/I DOS/VS 1.10
  - CICS/VSE 2.3
    - No DL/I support for CICS/VSE on z/VSE 4.3
    - No longer on base tapes
    - Not supported on z/VSE 5.1
    - End of service 10/31/2012
- See also Live Virtual Class on „z/VSE Release Migration Considerations”
  - Presentation is on <http://www-03.ibm.com/systems/z/os/zvse/education/#completed>

## *News related to z/VSE (since last z/VSE Announcement)*

- September: zBC12 GA
  - z/VSE Preventive Service Planning (PSP) bucket for details
  - [ibm.com/vse](http://ibm.com/vse) -> About z/VSE Status -> z/VSE server support
  - OSA/SF configuration on HMC – OSA-Express 4S / 5S only
    - For CHPID type OSE
  
- July: z/VM 6.3 GA
- July: zBC12 announced
- July: z/VSE Collection Kit available
- July: IPv6/VSE decreased monthly workload license charges
  
- June: z/VSE 5.1.2 Recommended Service Level (RSL) available
- June: z/VSE 5.1.2, including z/VSE additional enhancements available
  - Now on DVD-ROM
  
- May: New z/VSE web page layout
  
- April: z/VM 6.1 end of service
- April: z/VSE 5.1 additional enhancements announced

## *Documentation related to z/VSE*

- z/VSE Collection Kit July 2013
  - Available for download in IBM Publication Center
  - Electronic only, not on physical DVD
  
- Documentation of z/VSE releases
  - z/VSE Internet Library on <http://www.ibm.com/systems/z/os/zos/bkserv/vse.html>
  
- IBM Redbooks
  - Draft: Setup Linux on System z for Production, SG24-8137
  - Redbook page with new IBM System z mainframe Redbooks
    - zEC12 / zBC12 Technical Guide, SG24-8049 / SG24-8138
    - IBM System z Connectivity Handbook, SG24-5444

## *z/VSE Requirements*

- You may submit requirements at conferences (WAVV, GSE, ...)
- ... or via our z/VSE requirements page:
  - <https://www-03.ibm.com/systems/z/os/zvse/contact/requirement.html>
- ... or you may enter **CICS Transaction Server** requirements via the
  - Request for Enhancement (RFE) database:
    - <http://www.ibm.com/developerworks/rfe/>
  - Please select the following for z/VSE-CICS requirements:
    - *Brand = WebSphere*
    - *Product family = Transaction Processing*
    - *Product = CICS Transaction Server*
    - *Component = Runtime or Explorer*
    - *Operating system = IBM z/VSE*

## Be Social with z/VSE



**z/VSE Homepage:**  
[www.ibm.com/zVSE](http://www.ibm.com/zVSE)

 **Twitter**  
[www.twitter.com/IBMzVSE](http://www.twitter.com/IBMzVSE)

 **Ingolf's z/VSE Blog**  
[www.ibm.com/developerworks/mydeveloperworks/blogs/vse/](http://www.ibm.com/developerworks/mydeveloperworks/blogs/vse/)



**Join System z Advocates (Subgroup z/VSE)**  
[www.linkedin.com](http://www.linkedin.com)

**Read at the IBMs System z Blog**  
[www-304.ibm.com/connections/blogs/systemz/](http://www-304.ibm.com/connections/blogs/systemz/)

**Connect at Facebook**  
[www.facebook.com/IBMSystemz](http://www.facebook.com/IBMSystemz)

**Watch on YouTube**  
[www.youtube.com/user/IBMSystemZ](http://www.youtube.com/user/IBMSystemZ)

## *More Information*

... on VSE home page: <http://ibm.com/vse>

- Ingolf's z/VSE blog: <https://www.ibm.com/developerworks/mydeveloperworks/blogs/vse>
- **Hints and Tips for z/VSE 5.1:**
  - <http://www.ibm.com/systems/z/os/zvse/documentation/#hints>
- 64 bit virtual information:
  - IBM z/VSE Extended Addressability, Version 5 Release 1
  - IBM z/VSE System Macro Reference, Version 5 Release 1
- CICS Explorer: <http://www.ibm.com/software/htp/cics/explorer/>
- IBM Redbooks:
  - Introduction to the New Mainframe: z/VSE Basics  
<http://www.redbooks.ibm.com/abstracts/sg247436.html?Open>
  - Security on IBM z/VSE – updated  
<http://www.redbooks.ibm.com/Redbooks.nsf/RedbookAbstracts/sg247691.html?Open>
  - z/VSE Using DB2 on Linux for System z  
<http://www.redbooks.ibm.com/abstracts/sg247690.html?Open>