

VS05 - z/VSE 5.1 Neuigkeiten

Ingolf Salm
salm@de.ibm.com

Trademarks

The following are trademarks of the International Business Machines Corporation in the United States and/or other countries.

IBM*
IBM Logo*

* Registered trademarks of IBM Corporation

The following are trademarks or registered trademarks of other companies.

Adobe, the Adobe logo, PostScript, and the PostScript logo are either registered trademarks or trademarks of Adobe Systems Incorporated in the United States, and/or other countries.

Cell Broadband Engine is a trademark of Sony Computer Entertainment, Inc. in the United States, other countries, or both and is used under license therefrom.

Java and all Java-based trademarks are trademarks of Sun Microsystems, Inc. in the United States, other countries, or both.

Microsoft, Windows, Windows NT, and the Windows logo are trademarks of Microsoft Corporation in the United States, other countries, or both.

INFINIBAND, InfiniBand Trade Association and the INFINIBAND design marks are trademarks and/or service marks of the INFINIBAND Trade Association.

Intel, Intel logo, Intel Inside, Intel Inside logo, Intel Centrino, Intel Centrino logo, Celeron, Intel Xeon, Intel SpeedStep, Itanium, and Pentium are trademarks or registered trademarks of Intel Corporation or its subsidiaries in the United States and other countries.

UNIX is a registered trademark of The Open Group in the United States and other countries.

Linux is a registered trademark of Linus Torvalds in the United States, other countries, or both.

ITIL is a registered trademark, and a registered community trademark of the Office of Government Commerce, and is registered in the U.S. Patent and Trademark Office.

IT Infrastructure Library is a registered trademark of the Central Computer and Telecommunications Agency, which is now part of the Office of Government Commerce.

* All other products may be trademarks or registered trademarks of their respective companies.

Notes:

Performance is in Internal Throughput Rate (ITR) ratio based on measurements and projections using standard IBM benchmarks in a controlled environment. The actual throughput that any user will experience will vary depending upon considerations such as the amount of multiprogramming in the user's job stream, the I/O configuration, the storage configuration, and the workload processed. Therefore, no assurance can be given that an individual user will achieve throughput improvements equivalent to the performance ratios stated here.

IBM hardware products are manufactured from new parts, or new and serviceable used parts. Regardless, our warranty terms apply.

All customer examples cited or described in this presentation are presented as illustrations of the manner in which some customers have used IBM products and the results they may have achieved. Actual environmental costs and performance characteristics will vary depending on individual customer configurations and conditions.

This publication was produced in the United States. IBM may not offer the products, services or features discussed in this document in other countries, and the information may be subject to change without notice. Consult your local IBM business contact for information on the product or services available in your area.

All statements regarding IBM's future direction and intent are subject to change or withdrawal without notice, and represent goals and objectives only.

Information about non-IBM products is obtained from the manufacturers of those products or their published announcements. IBM has not tested those products and cannot confirm the performance, compatibility, or any other claims related to non-IBM products. Questions on the capabilities of non-IBM products should be addressed to the suppliers of those products.

Prices subject to change without notice. Contact your IBM representative or Business Partner for the most current pricing in your geography.

Agenda

- Roadmap
- z/VSE 5.1 key functions
- z/VSE 5.1 additional enhancements
- CICS Explorer

VSE Roadmap

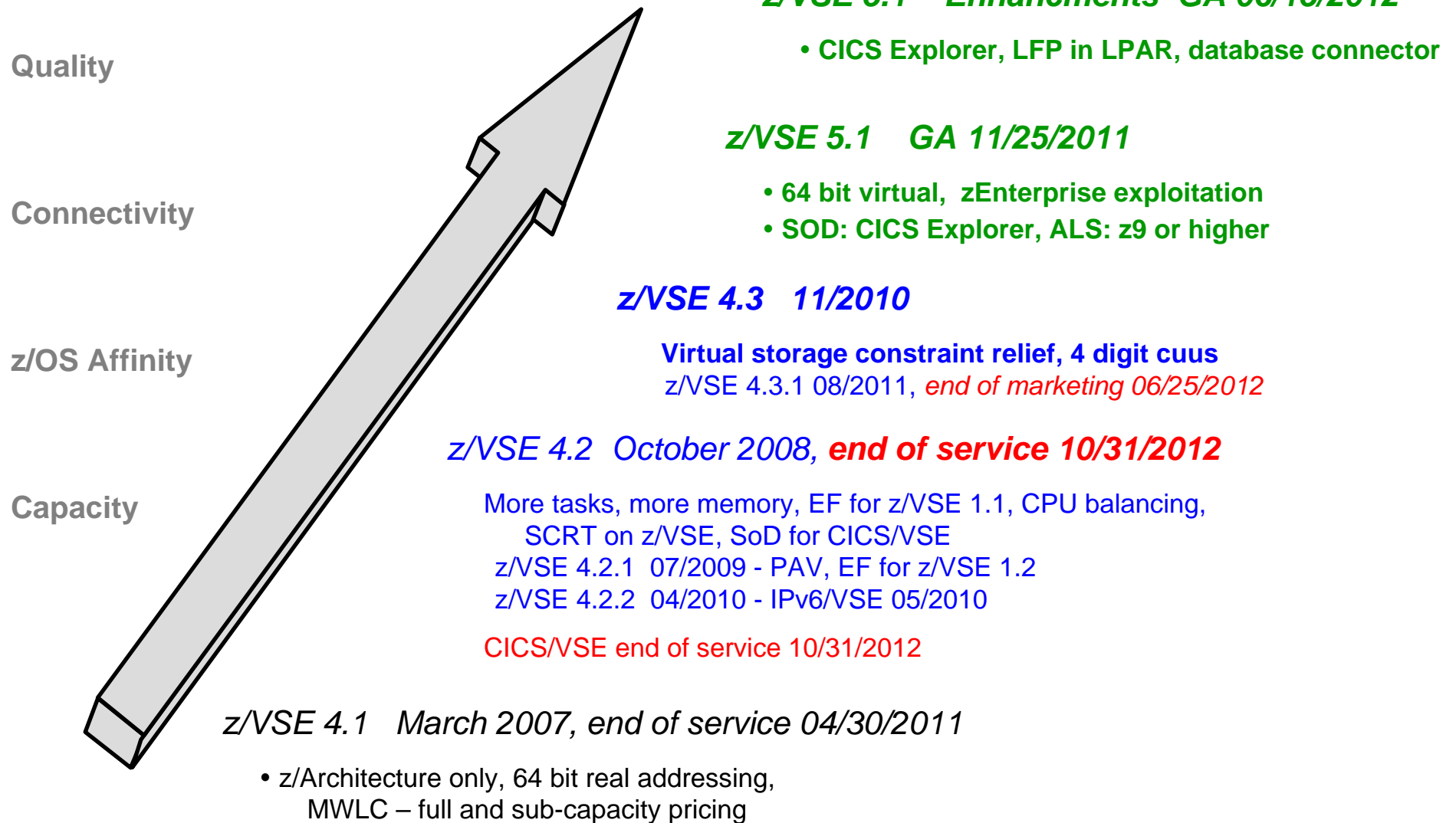

VSE Strategy

- Helps **Protect** your existing investments in core VSE programs, data, equipment, IT skills, *plus* business processes, end user training, etc.
 - modernize, i.e. extend VSE resources to Web
 - exploit IBM servers, storage, and software
- **Integrate** VSE with the rest of your IT based on open and industry standards
 - (IBM) middleware
 - VSE connectors and web services
- **Extend** with Linux on System z
 - infrastructure consolidation/simplification
 - add new infrastructure and/or line-of-business applications

Why Not Think Inside the Box?

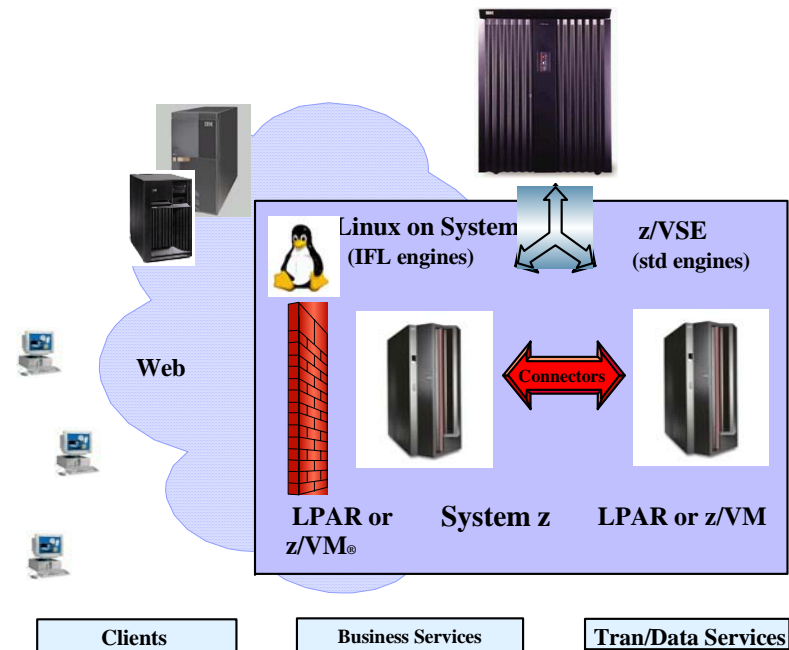

z/VSE V5.1

- Preview: 04/12/2011, Announcement: 10/12/2011, GA 11/25/2011
- 64-bit virtual addressing
- Introduces Architectural Level Set (ALS) that requires System z9 or later
- IBM zEnterprise 196 (z196) and IBM zEnterprise 114 (z114) exploitation
 - Support Static Power Save Mode for MWLC clients with subcapacity option (z196 only)
 - 4096-bit RSA keys with Crypto Express3 for enhanced security
 - Support of OSA-Express for zBX (CHPID OSX) to participate in an Intra Ensemble Data Network (IEDN) in z/VM guest or LPAR
- Exploitation of IBM System Storage options
 - Copy Export function of TS7700 Virtualization Engine for disaster recovery
 - Multi-Cluster Grid support of the TS7700 Virtualization Engine Series (TS7700)
 - IBM Storwize V7000 Midrange Disk System (z/VSE 4.2 and later)
 - IBM XIV (z/VSE 4.2 and later)
- Fast Service Upgrade (FSU) from z/VSE 4.2 and z/VSE 4.3
- Pricing
 - Midrange Workload License Charge (MWLC) pricing with sub-capacity option
 - z114: Advanced Entry Workload License Charge (AEWLC) pricing with sub-capacity option

z/VSE V5.1

- Networking enhancements
 - IPv6 support for Linux Fast Path
 - z/VSE z/VM IP Assist (VIA) exploitation
 - TCP/IP communication using Layer 2 (Data Link Layer)
 - Virtual Local Area Network (VLAN) support for OSA Express and Hipersockets
 - Global VLAN supported by TCP/IP for VSE/ESA and IPv6/VSE
 - General VLAN supported by IPv6/VSE

- IPv6/VSE
 - Large TCP window support, can increase throughput
 - 64 bit virtual exploitation, large TCP window storage allocated above the bar
 - Layer 2 support (OSA Express, IPv6 only)
 - VLAN support

- System management enhancements
 - SNMP Trap Client Extension monitoring – API

- High availability and disaster recovery enhancements
 - Copy Export function of TS7700 Virtualization Engine for disaster recovery
 - Multi-Cluster Grid support of the TS7700 Virtualization Engine Series (TS7700)
 - GDPS (Geographically Dispersed Parallel Sysplex) client (in a z/VM guest)
 - z/VSE supports heartbeat only
 - GDPS K-system can only monitor z/VSE
 - GDPS K-system can manage z/VM and therefore can manage z/VSE indirectly

z/VSE V5.1 ...

- System enhancements
 - Language Environment enhancements
 - PL/I multitasking enhancements
 - C run-time socket API to include IPv6 related functions
 - Callable service sample for programs
 - Additions to system programmer C samples
 - Updated LE/C support for Librarian Members, and updates to the CEETRACE utility.
 - E-business connector enhancements
 - VSE Script Connector to support LIBR access
 - VSE/POWER
 - Token as new job attribute to address spooled output
 - VTAPE enhancements
 - VTAPE Auto Close at EOJ dependent on new SCOPE keyword
 - SCOPE= SYSTEM or JOB
 - TAPE UNLOAD at EOJ (TAPE UNL=EOJ)

- CICS - Statement of general direction (SOD):
 - IBM intends to provide CICS Explorer capabilities for CICS TS for VSE/ESA, to deliver additional value.

All statements regarding IBM's plans, directions, and intent are subject to change or withdrawal without notice.

z/VSE 5.1 Announcement (04/03/2012)

- IBM z/VSE V5.1 - Additional enhancements available
- Announcement content for
 - GA on June 15, 2012:
 - CICS Explorer for z/VSE
 - Linux Fast Path in LPAR
 - Linux Fast Path via z/VSE z/VM IP Assist (z/VSE VIA)
 - z/VSE database connector
 - VSE/POWER enhancement to ease job output handling
 - IBM System Storage Tape Controller 3592 Model C07

 - (new symbolic parameter IJBVMID containg the z/VM userid if running on z/VM)
 - Later PTFs (after June 15, 2012)
 - 64-bit input/output (I/O) processing for applications
 - IPv6/VSE V1.1 enhancements
 - o Secure Sockets Layer (SSL) for secure data transmission
 - o Layer 2 support for OSA Express devices for IPv4 links

VSE Support for System z

VSE Release	z800 / z900	z890 / z990	System z9 / z10 / z196 / z114	VSE EoS
z/VSE V5.1	No	No	Yes	tbd
z/VSE V4.3	Yes	Yes	Yes	tbd
z/VSE V4.2	Yes	Yes	Yes	10/31/2012
z/VSE V4.1	Yes	Yes	Yes	04/30/2011
z/VSE V3.1	Yes	Yes	Yes	07/31/2009
VSE/ESA V2.7	Yes	Yes	Yes	02/28/2007
VSE/ESA V2.6	Yes	Yes	Yes	03/2006
VSE/ESA V2.5	Yes	No	No	12/2003
VSE/ESA V2.4	Yes	No	No	06/2002
VSE/ESA V2.3	No	No	No	12/2001

IBM zEnterprise exploitation

- 64 bit real addressing - up to 32 GB (System z)
- 64 bit virtual virtual addressing – up to 90 GB (System z)
- Large page support (z10, zEnterprise)
- Dynamic add of logical CPs (z10, zEnterprise)
- Linux Fast Path (LFP) in z/VM mode LPAR (z10, zEnterprise)
- Exploitation of the z/VSE z/VM IP Assist (zEnterprise)

IBM zEnterprise exploitation

- 4096-bit RSA key support with configurable Crypto Express3 (z10, zEnterprise)
- zEnterprise and zEnterprise BladeCenter Extension (zBX) support
 - “native” Intra Ensemble Data Network (IEDN)
 - Virtual LAN support
 - Layer 2 support
 - IEDN communication using the z/VM VSWITCH
- HiperSockets Completion Queue on z196 and z114 (available June 15, 2012)
- Static power save mode supported for SCRT (z196 only)
- Statement of general direction:
 - The IBM zEnterprise 196 and IBM zEnterprise 114 are the last System z servers to support ESCON channels.
 - See IBM Hardware Announcement 111-136, July 12, 2011

All statements regarding IBM's plans, directions, and intent are subject to change or withdrawal without notice.

zEnterprise zManager (HMC) and z/VSE

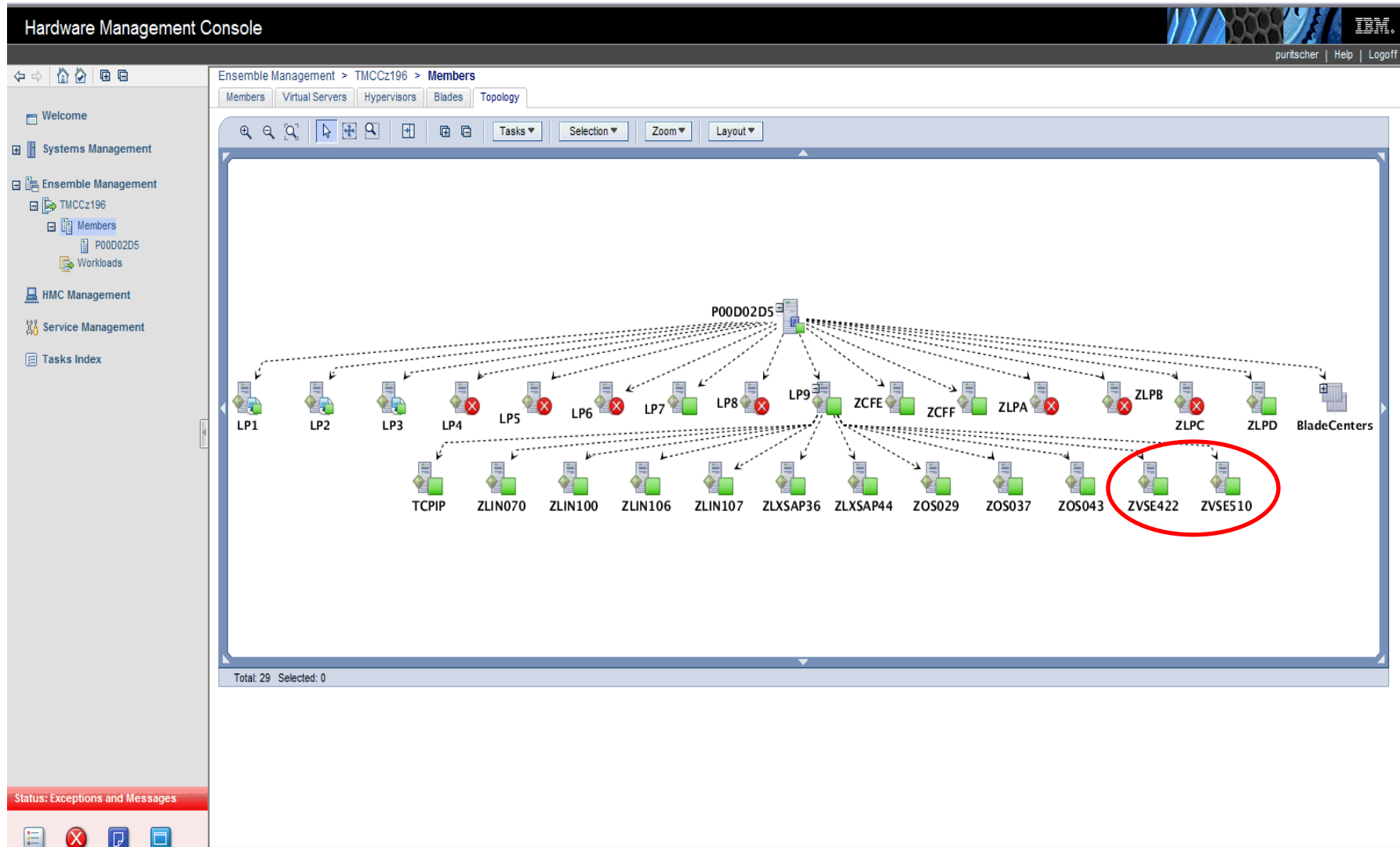

zEnterprise zManager (HMC) and z/VSE

Hardware Management Console

Ensemble Management > TMCCz196 > Members

Members Virtual Servers Hypervisors Blades Topology

Select	Name	Member	Status	Processors	Memory (MB)	Type	Auto Start	Shutdown Timeout
<input type="checkbox"/>	P00D02D5		Operating			PR/SM		
<input type="checkbox"/>	LP9	P00D02D5	Operating			z/VM	--	300
<input type="checkbox"/>	TCP/IP	P00D02D5	Operating	1	128	z/VM		
<input type="checkbox"/>	ZLIN070	P00D02D5	Operating	2	3,072	z/VM		
<input type="checkbox"/>	ZLIN100	P00D02D5	Operating	2	1,024	z/VM		
<input type="checkbox"/>	ZLIN106	P00D02D5	Operating	4	6,144	z/VM		
<input type="checkbox"/>	ZLIN107	P00D02D5	Operating	1	1,024	z/VM		
<input type="checkbox"/>	ZLXSAP36	P00D02D5	Operating	2	6,144	z/VM		
<input type="checkbox"/>	ZLXSAP44	P00D02D5	Operating	2	6,144	z/VM		
<input type="checkbox"/>	ZOS029	P00D02D5	Operating	4	2,048	z/VM		
<input type="checkbox"/>	ZOS037	P00D02D5	Operating	4	16,384	z/VM		
<input type="checkbox"/>	ZOS043	P00D02D5	Operating	4	16,384	z/VM		
<input checked="" type="checkbox"/>	ZVSE422	P00D02D5	operating	2	1,024	z/VM		
<input type="checkbox"/>	ZVSE510	P00D02D5	operating	3	2,048	z/VM		
<input type="checkbox"/>	ZLPA	P00D02D5	Operating				--	300

Virtual Server Details
 Toggle Lock
 Daily
 Configuration
 Monitor

Page Size: 500 Total: 19 Filtered: 19 Selected: 1

Tasks: ZVSE422

- Virtual Server Details
- Toggle Lock
- Daily
 - Activate
 - Deactivate
 - Grouping
- Configuration
 - Delete Virtual Server
 - New Virtual Server Based On
- Monitor
 - Monitor System Events

Status: Exceptions and Messages

zEnterprise zManager (HMC) and z/VSE

Virtual Server Details - ZVSE422 [P00D02D5:LP9:TMCC40]

Name | Status | **Processors** | Memory | Network | Storage | Options | Workloads | Performance

Initial virtual processors: * 2

Maximum virtual processors: * 2

Share limit: None

Initial share mode: Relative

Initial relative shares: * 2000

OK | Apply | Cancel | Help

Encryption Facility for z/VSE

- Optional priced feature for VSE Central Functions
- Supports the use of SAM files, VSE/VSAM files, VSE library members, tapes, virtual tapes as input or output
- Requires CP Assist for Cryptographic Function (CPACF)
 - no charge feature, only on z890, z990, z9, z10, z114 and z196 servers
- Extends affinity between z/VSE and z/OS
 - Function roughly equivalent to EF for z/OS 1.1
 - Compatible with EF for z/OS V1.1 (Encryption Facility System z format)
 - EF for z/VSE tapes can be read by EF for z/VSE, EF for z/OS, EF for z/OS Java Client, and Decryption Client for z/OS,
 - EF for z/OS V1.1 and EF for z/OS Java client tapes can be read by EF for z/VSE
- EF for z/VSE 1.2
 - Supports z/VSE 4.2 and later
 - Supports openPGP standard
 - **OpenPGP exploits 4096-bit RSA keys (z10, zEnterprise)**

TCP/IP Connectivity for z/VSE

- TCP/IP connectivity for IPv4 communication
 - TCP/IP for VSE/ESA 1.5 – licensed from CSI International
 - IPv6/VSE – licensed from Barnard Software, Inc. (BSI)
 - Linux fast path (LFP)
 - EZA socket interface, new function calls
 - LE/C socket API

- TCP/IP connectivity for IPv6 communication
 - IPv6/VSE
 - EZA socket interface, new function calls
 - **Linux Fast Path (z/VSE 5.1)**

- All TCP/IP stacks can run concurrently within one z/VSE system

- z/VM queue-I/O assist for real networking devices
 - Performance assist for OSA-Express adapters and HiperSockets

IPv6/VSE

- Announced: 04/06/2010, GA 05/28/2010, **updated**
- Full function IPv4 and IPv6 stack with applications
 - MWLC with sub-capacity option for IPv6/VSE product
 - Supported releases: z/VSE 4.2 plus PTFs, z/VSE 4.3 or z/VSE 5.1
 - Optional Product of z/VSE 4.3 and z/VSE 5.1
- IPv6 solution for z/VSE
 - Includes the IPv6 stack, IPv6 APIs and IPv6-enabled applications
 - IBM's EZA Assembler interfaces support IPv4 and IPv6 communication
 - Extends 32 bit addresses (used in IPv4) to 128 bit addresses
 - To meet requirements of governmental agencies for products
- **z/VSE 5.1 enhancements**
 - **Large TCP window support, can increase throughput**
 - **64 bit virtual exploitation, large TCP window storage allocated above the bar**
 - **Layer 2 (data link layer, OSA Express devices for IPv6 only) and Layer 3 (IP layer) support**
 - **VLAN support**
 - **On extended base tape**
- **z/VSE 5.1 additional enhancements (after June 15, 2012)**
 - **Secure Sockets Layer (SSL) for secure data transmission**
 - **Layer 2 support for OSA Express devices for IPv4 links**

z/VSE 5.1 Networking Enhancements

- **Layer 3 (IP layer)**
 - TCP/IP stack uses IP packets that include IP addresses
 - Default mode for OSA Express and HiperSockets
 - Supported by TCP/IP for VSE/ESA and IPv6/VSE
 - Used on z/VSE 5.1 and prior releases

- **Layer 2 (data link layer) support**
 - TCP/IP stack uses Ethernet frames with MAC addresses
 - Device driver supports IPv4 and IPv6 communication, HiperSockets and OSA Express devices
 - Required for IPv6 communication through the z/VM VMSWITCH
 - Supported by IPv6/VSE (OSA Express only)
 - Can be used on z/VSE 5.1 only

- **Virtual LAN (VLAN) support**
 - Allows to divide a physical network into separate logical networks
 - For OSA Express and HiperSocket devices
 - Layer 3: VLANs can be transparently used by TCP/IP for VSE/ESA and IPv6/VSE
 - Layer 2: VLANs can be used by IPv6/VSE only

- **Global VLAN support**
 - One global VLAN per link
 - Global VLANs defined in IJBOCONF – to be used OSX devices
 - IEDN requires OSA Express for zBX devices (OSX)

Linux Fast Path (LFP)

- Routes IPv4 or IPv6 socket request to Linux on System z
 - Without using the local TCP/IP stack
- LFP on z/VM (z/VSE 4.3 or higher)
 - Uses an IUCV connection between z/VSE and Linux on System z
 - Both – z/VSE and Linux – need to be z/VM guests of the same z/VM
 - LFP daemon on Linux forwards the socket request to the Linux TCP/IP stack
 - Will run best in **z/VM mode LPAR** (z/VM 5.4 or higher)
 - Available on z10, z114 and z196; Linux on System z on IFL, z/VSE on standard processors
 - System requirements: z/VM 5.4 or higher, Linux on System z distribution (RHEL, SLES)
- Linux Fast Path using z/VSE z/VM IP Assist (VIA – z/VSE 5.1)
 - Both – z/VSE and Linux – need to be z/VM guests of the same z/VM
 - System requirements: z114 or z196, z/VM 6.1 or later
- Linux Fast Path in LPAR (z/VSE 5.1 + enhancements – GA 06/15/2012)
 - LFP daemon on Linux forwards the socket request to the Linux TCP/IP stack
 - System requirements: z114 or z196, Linux on System z distribution (RHEL, SLES)
- LFP is transparent to IBM socket APIs
 - Supported APIs: LE/C socket API, EZA socket / EZASMI interface, ...
 - Transparent to IBM applications (DB2 client, Connectors, Power PNET)
 - No standard TCP/IP applications (Telnet, FTP, ...) provided
 - IPv6/VSE: TCP/IP applications can exploit LFP
- Provided with the z/VSE base product – no additional charge

Linux Fast Path (LFP) - Linux Fast Path on z/VM

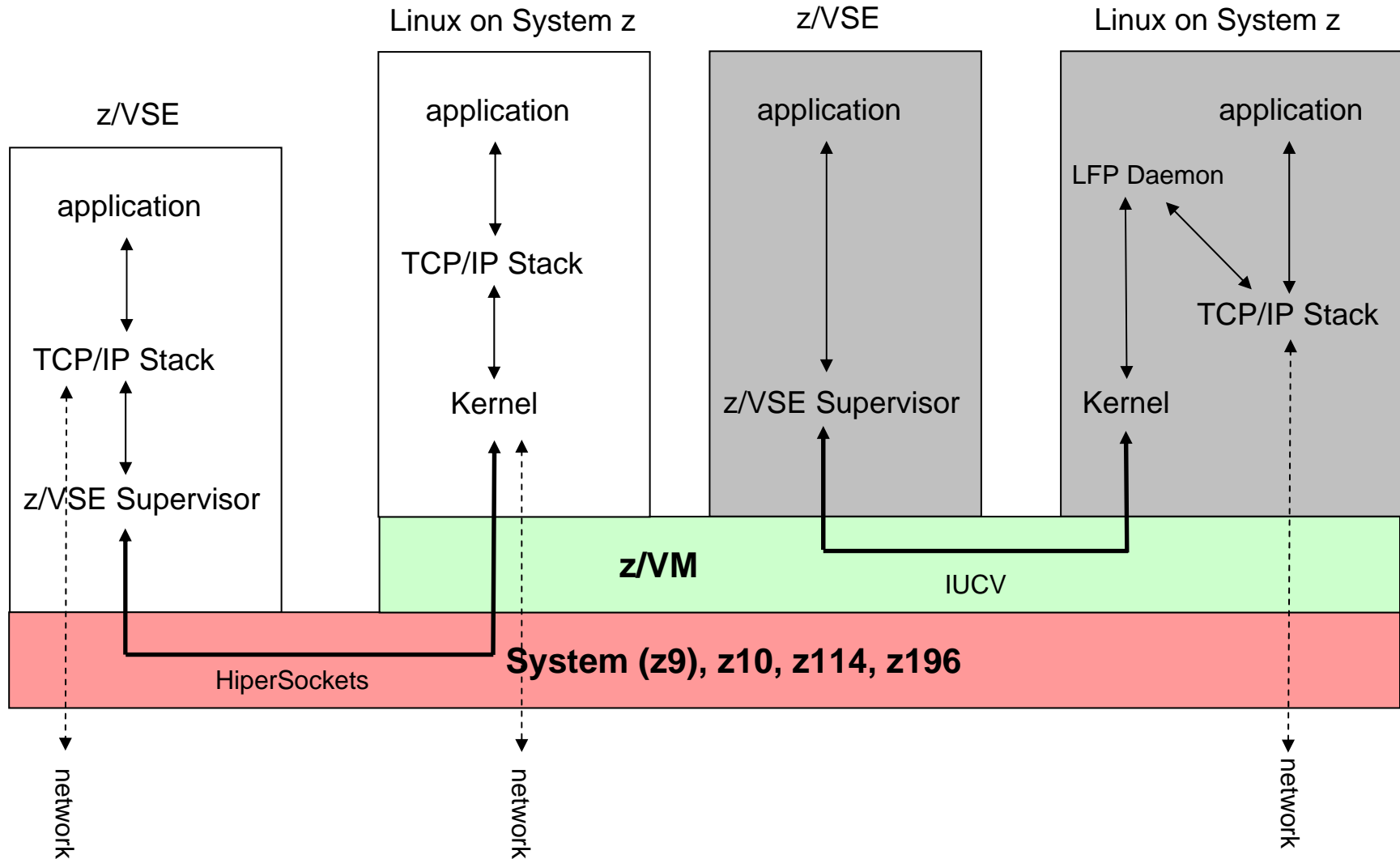

LFP - z/VSE z/VM IP Assist (VIA) – z/VSE 5.1

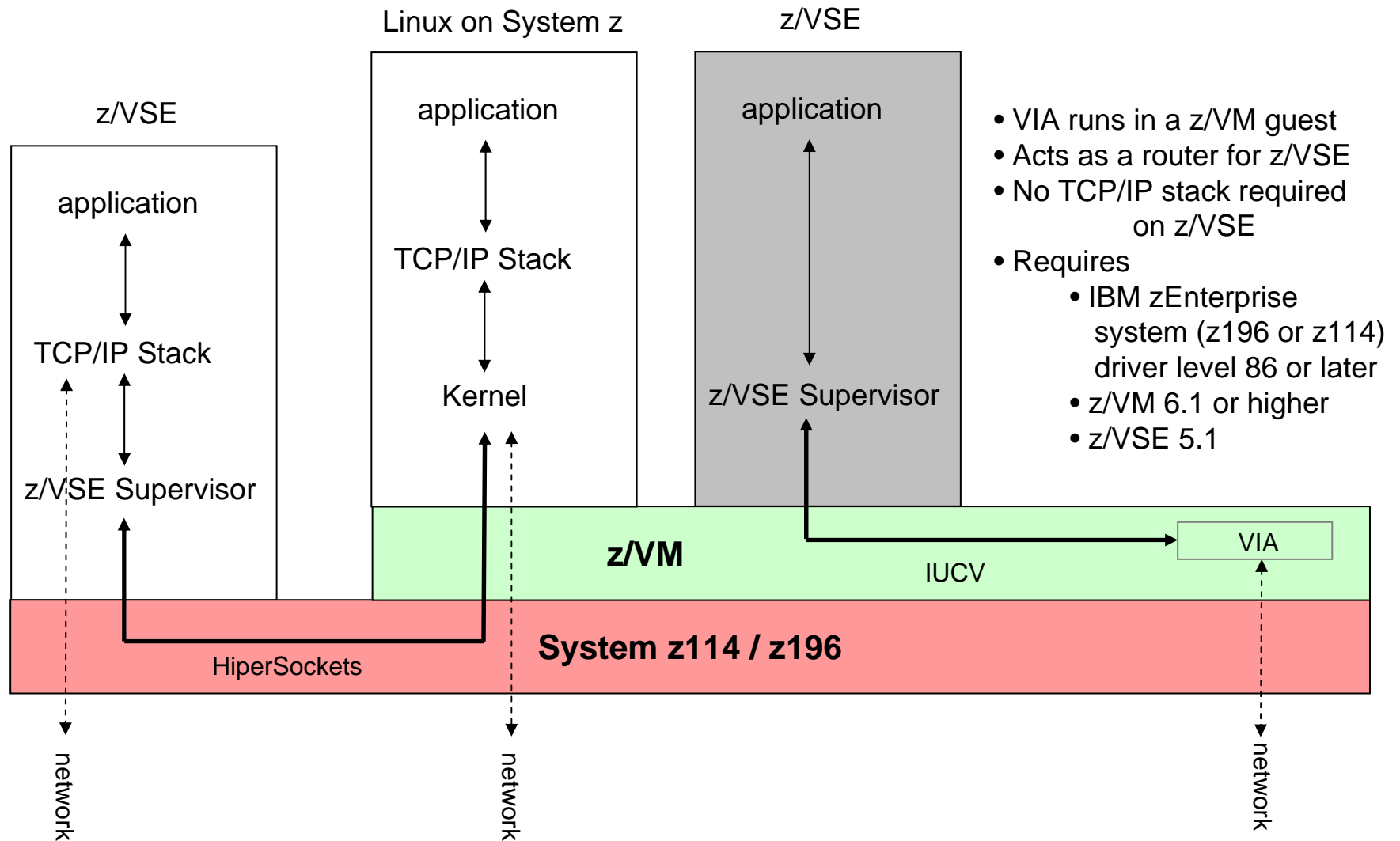

Linux Fast Path (LFP) – Linux Fast Path in LPAR

- No TCP/IP stack required on z/VSE
- System requirements
 - Supported on z114 and z196
 - Exploits HiperSockets completion queue
 - Linux on System z distribution (RHEL, SLES)
 - z/VSE 5.1 + PTF
- Available June 15, 2012

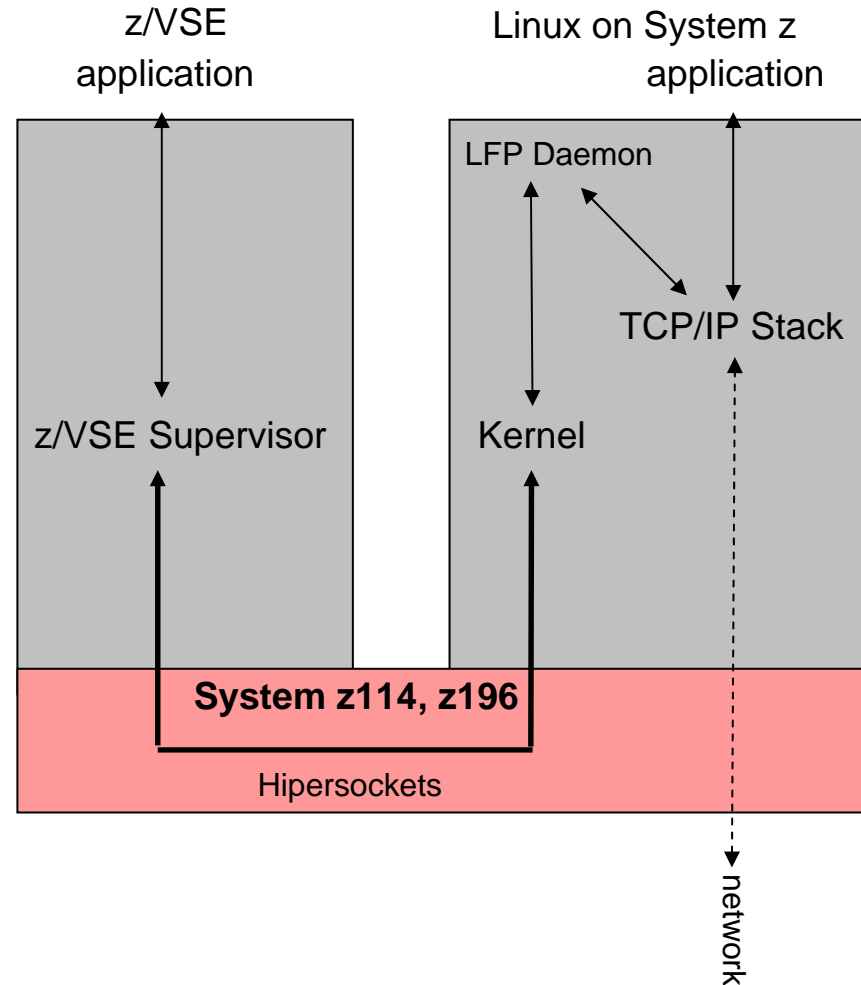

Connectors

■ SNMP Connector

- SNMP (Simple Network Management Protocol) V1 protocol
- Allows to monitor system events on a network
- Clients can retrieve z/VSE specific system and performance data
- Performance monitors may collect the data for planning purposes
- **SNMP Trap Client Extension monitoring – API**

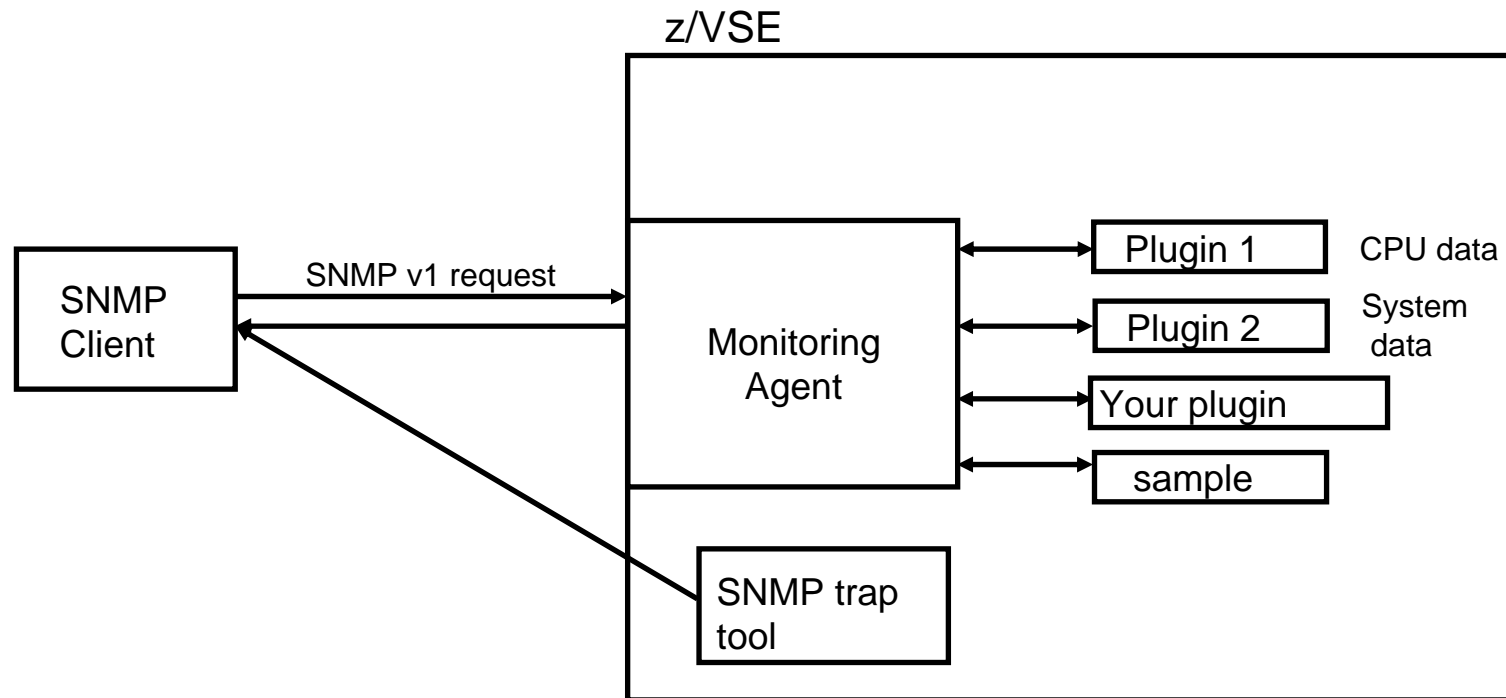

Data Base Connector

- Available June 15, 2012
- Provides a database call level interface (DBCLI)
 - For HLASM, COBOL, PL/I, C or REXX applications
- Connects to a remote database
- Consists of
 - DBCLI client on z/VSE
 - DBCLiServer on any Java-capable platform

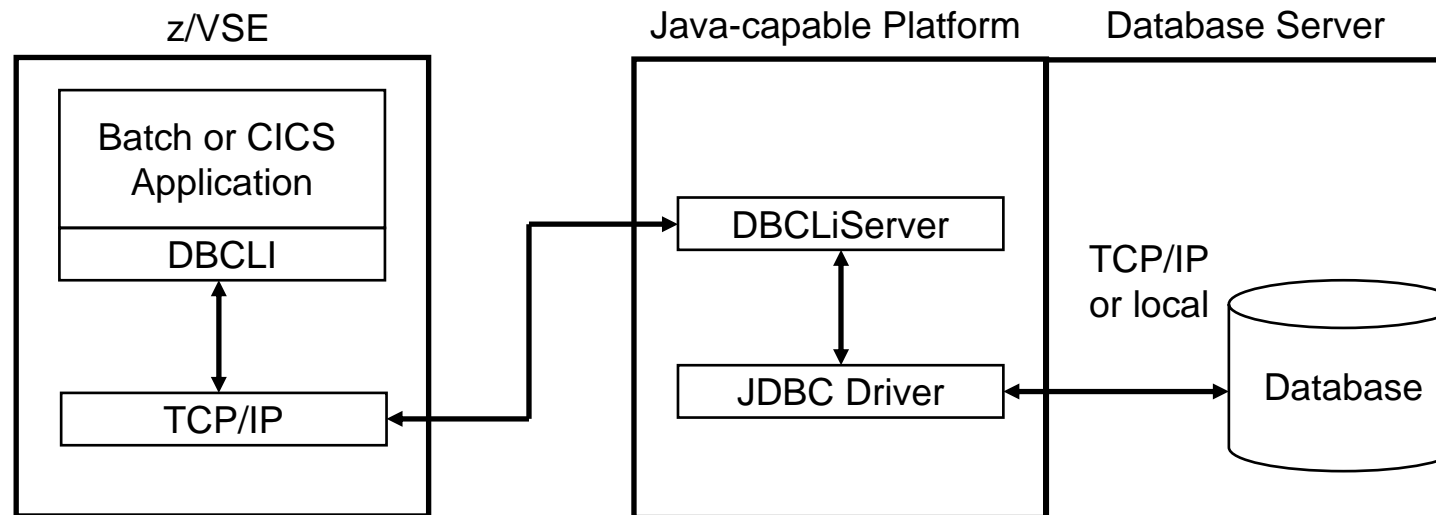

64 bit virtual

- Support 64 bit virtual addressing
- 64 bit area can be used for **data only**
 - No instruction execution above the bar
- **z/OS affinity:** APIs (IARV64 services) - to manage memory objects – compatible with z/OS
 - Private memory objects for use in one address space
 - Shared memory objects to be shared among multiple address spaces
- Maximum VSIZE still limited to 90 GB
- Advantages:
 - Eases the access of large amounts of data
 - E.g. instead of using and managing data spaces
 - Reduces complexity of programs
 - Data contained in primary address space
 - Chosen design has no dependencies to existing APIs, minor impact on existing system code

64 bit virtual – Define System Limits

SYSDEF statement to define the limits for memory objects

- Before IARV64 macro can be used.
- SYSDEF MEMOBJ,MEMLIMIT=,SHRLIMIT=,LFAREA=,LF64ONLY
 - MEMLIMIT – maximum virtual storage available for memory objects
 - o Theoretical maximum value is VSIZE.
 - SHRLIMIT – maximum virtual storage available for shared memory objects
 - = size of extended area, included in MEMLIMIT
 - LFAREA – maximum real storage to fix private memory objects
 - LF64ONLY – YES|NO – memory objects are fixed in 64 bit frames only

– Example:

```
sysdef memobj, memlimit=1g, shrlimit=500m, lfarea=10m
AR 0015 1140I  READY
```

64 bit virtual – Display Memory Object Information

- QUERY command to retrieve memory object information
 - QUERY MEMOBJ displays
 - Effective settings of MEMLIMIT, SHRLIMIT; LFAREA, LF64ONLY
 - Summary information: virtual storage consumption of private / shared memory objects
 - QUERY MEMOBJ,ALL displays
 - Additional statistic information
 - Virtual storage consumption of shared memory objects
 - Virtual storage consumption of private memory objects per partition
 - Example

```
query memobj
AR 0015          LIMITS      USED      HWM
AR 0015 MEMLIMIT:  1024M      0M        1M
AR 0015 SHRLIMIT:   500M      0M        0M
AR 0015 LFAREA:     10M        OK        OK
AR 0015 LF64ONLY:  NO
AR 0015 1I40I  READY
```

64 bit virtual - IARV64 Macro

- IARV64 macro - ported from z/OS – provides services to
 - Creates and frees storage areas above the bar
 - Manage the physical frames behind the storage

- Programs use the IARV64 macro to obtain memory objects

- Services (IARV64 REQUEST=):
 - GETSTORE – create a private memory object
 - GETSHARED – create a memory object that can be shared across multiple address spaces
 - SHAREMEMOBJ – request that the specified address space be given access to a shared memory object
 - DETACH – free one or more memory objects
 - PAGEFIX – fix pages within one or more private memory objects
 - PAGEUNFIX – unfix pages within one or more private memory objects

 - GETSTORE / GETSHARED KEY parameter (default key = key of caller)
 - Unauthorized caller can set key 9 (all tasks can run in key 9)
 - Authorized callers can set any key

64 bit virtual - Address Space Layout

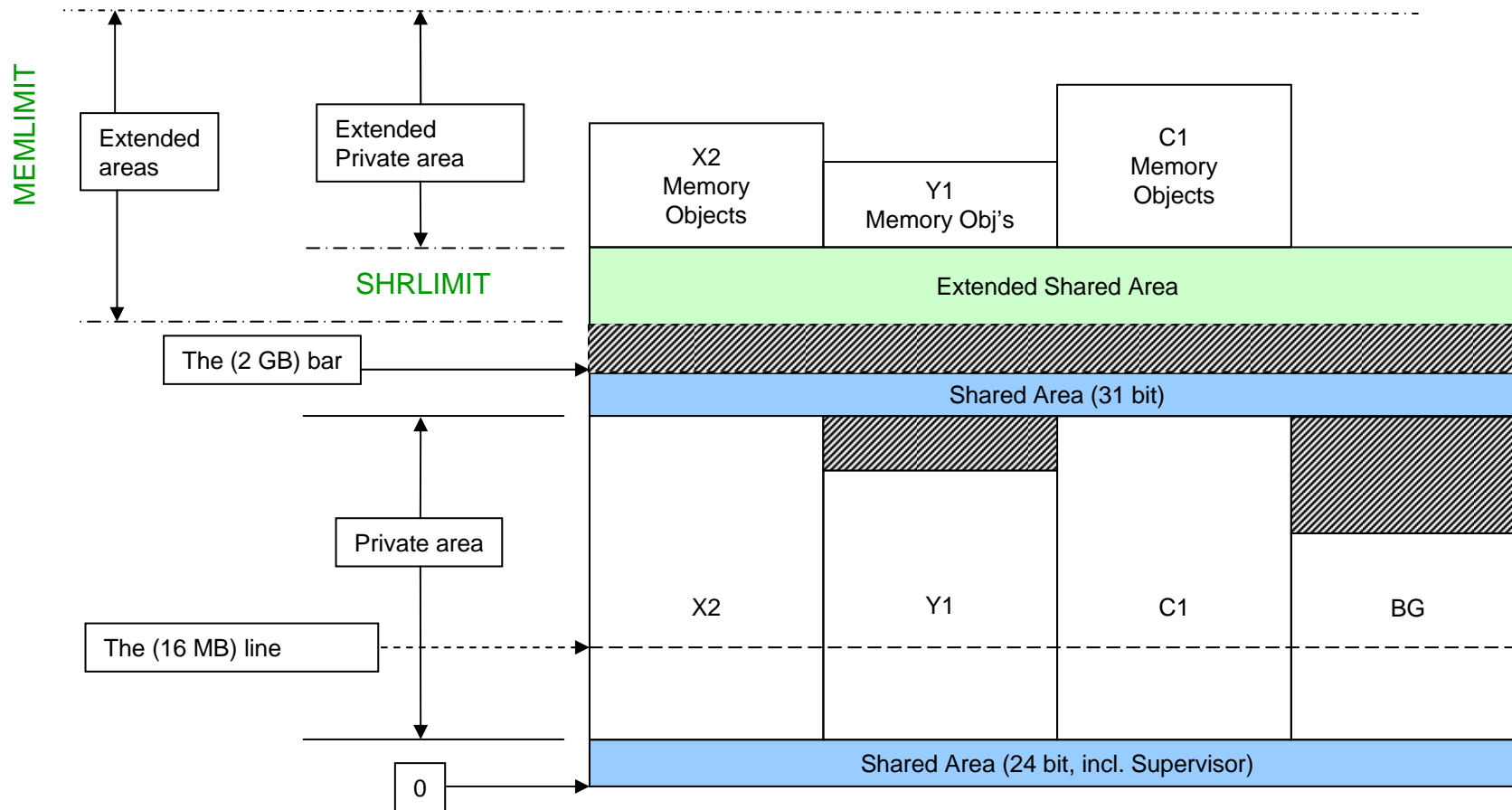

64 bit virtual I/O

- Extend z/VSE's 64 bit virtual support to 64 bit virtual I/O
- Ensures z/OS compatibility for EXCP interfaces
- DASD (ECKD) support only
- I/O can only be done for private memory objects
- Format 0 and Format 1 CCW with Format 2 IDAWs
 - New CCB parameter
- Not supported by VSAM, BAM (LIOCS)
- Available via z/VSE 5.1 PTF some time after June 15, 2012

CICS

- CICS/VSE 2.3
 - No longer in the z/VSE 4.3 base
 - Not supported on z/VSE 5.1
 - End of service: 10/31/2012
 - Recommendation: Migration to CICS TS on z/VSE 4.2 or earlier

- DOS/VS RPG II compiler support for CICS TS
 - Allows RPG programs implemented for CICS/VSE V2.3 to run with CICS TS
 - Will be available on z/VSE 4.2 (z/VSE 4.1) via PTF (see Info. APAR II4447)

- New DL/I VSE 1.12 release since z/VSE 4.3
 - Optional product of z/VSE 4.3 and z/VSE 5.1 (the only DL/I release)
 - Provides constraint release (DL/I resources moved above the 16 MB line)
 - Replaces DL/I VSE 1.11 and DL/I DOS/VS 1.10
 - Does not support CICS/VSE 2.3
 - No DL/I support for CICS/VSE on z/VSE 4.3

CICS Explorer for z/VSE

- Fulfills statement of general direction (SOD):
IBM intends to provide CICS Explorer capabilities for CICS TS for VSE/ESA, to deliver additional value.

- Announced 04/03/2012, planned availability 06/15/2012

- CICS Explorer – The new face to CICS
 - New system management framework for CICS TS
 - Consists of CICS Explorer client and a CICS TS server extension
 - CICS Explorer client
 - Read-only capabilities
 - Eclipse-based user interface on workstation
 - Connects to CICS TS via TCP/IP
 - Communication via HTTP requests
 - CICS Explorer server extension
 - Delivered as PTF for CICS TS for VSE/ESA 1.1.1
 - z/VSE 5.1 only

IBM CICS Explorer BETA - C:/CICS-Work

Explorer Edit Project Operations Definitions Search Window Help

Regions TCP/IP S ISC/MR Terminal Transact Transact Program Tasks Files Interval TD Queu TS Queu

Server: CIC2 CNX0211I Context: PRODCICS. Resource: CICSRGN. 1 records collected at Apr 4, 2012 5:54:01 PM Job Name:

Region	Job Name	MVS System...	Task Count	CICS Status	CICS TS Level	CICS Release	Total CPU	Page In Count	Page Out C...	I/O Count
PRODCICS	CICS2	N/A	4	✓ ACTIVE		V111	0000:00:00...	N/A	N/A	9507

IZE0100I Connected user SYSA to host lnxsalm1.boeblingen.de.ibm.com on port 27283 | lnx

IBM CICS Explorer BETA - C:/CICS-Work

Explorer Edit Project Operations Definitions Search Window Help

Regions TCP/IP S ISC/MR Terminal Transact Transact Program Tasks Files Interval TD Queu TS Queu

Server: CIC2 CNX0211I Context: PRODCICS. Resource: TERMNL. 65 records collected at Apr 4, 2012 6:09:00 PM

Region	Name	Network Name	Acquire Status	Service Status	ATI Status	TTI Status	Session Status	User ID	Transaction ID
PRODCICS	-AAA	TMPLETE1	RELEASED	INSERVICE	ATI	TTI	NOCREATE	CICSUSER	
PRODCICS	-AAB	TMPLETE1	RELEASED	INSERVICE	ATI	TTI	CREATE	CICSUSER	
PRODCICS	-AAC	TMPLETE1	RELEASED	OUTSERVICE	ATI	TTI	CREATE	CICSUSER	
PRODCICS	-AAD	TMPLETE1	RELEASED	OUTSERVICE	ATI	TTI	CREATE	CICSUSER	
PRODCICS	-AAE	TMPLETE1	RELEASED	OUTSERVICE	ATI	TTI	CREATE	CICSUSER	
PRODCICS	-AAF	TMPLETE1	RELEASED	OUTSERVICE	ATI	TTI	CREATE	CICSUSER	
PRODCICS	-AAG	TMPLETE1	RELEASED	OUTSERVICE	ATI	TTI	CREATE	CICSUSER	
PRODCICS	-AAH	TMPLETE1	RELEASED	OUTSERVICE	ATI	TTI	CREATE	CICSUSER	
PRODCICS	-AAI	TMPLETE1	RELEASED	OUTSERVICE	ATI	TTI	CREATE	CICSUSER	
PRODCICS	-AAJ	TMPLETE1	RELEASED	OUTSERVICE	ATI	TTI	CREATE	CICSUSER	
PRODCICS	-AAK	TMPLETE1	RELEASED	OUTSERVICE	ATI	TTI	CREATE	CICSUSER	
PRODCICS	-AAL	TMPLETE1	RELEASED	OUTSERVICE	ATI	TTI	CREATE	CICSUSER	
PRODCICS	-AAM	TMPLETE2	RELEASED	INSERVICE	ATI	TTI	CREATE	CICSUSER	
PRODCICS	-AAN	TMPLETE3	RELEASED	INSERVICE	ATI	TTI	NOCREATE	CICSUSER	
PRODCICS	-AAO	TMPLETE3	RELEASED	INSERVICE	ATI	TTI	CREATE	CICSUSER	
PRODCICS	-AAP	TMPLETE3	RELEASED	OUTSERVICE	ATI	TTI	CREATE	CICSUSER	
PRODCICS	-AAQ	TMPLETE3	RELEASED	OUTSERVICE	ATI	TTI	CREATE	CICSUSER	
PRODCICS	-AAR	TMPLETE3	RELEASED	OUTSERVICE	ATI	TTI	CREATE	CICSUSER	
PRODCICS	-AAS	TMPLETE3	RELEASED	OUTSERVICE	ATI	TTI	CREATE	CICSUSER	
PRODCICS	-AAT	TMPLETE3	RELEASED	OUTSERVICE	ATI	TTI	CREATE	CICSUSER	
PRODCICS	-AAU	TMPLETE3	RELEASED	OUTSERVICE	ATI	TTI	CREATE	CICSUSER	
PRODCICS	-AAV	TMPLETE3	RELEASED	OUTSERVICE	ATI	TTI	CREATE	CICSUSER	
PRODCICS	-AAW	TMPLETE3	RELEASED	OUTSERVICE	ATI	TTI	CREATE	CICSUSER	
PRODCICS	-AAX	TMPLETE3	RELEASED	OUTSERVICE	ATI	TTI	CREATE	CICSUSER	
PRODCICS	-AAZ	TMPLETE3	RELEASED	OUTSERVICE	ATI	TTI	CREATE	CICSUSER	
PRODCICS	CBRF	CBRF	RELEASED	INSERVICE	ATI	TTI	NOCREATE	CICSUSER	
PRODCICS	CERR		NOTAPPLIC	INSERVICE	NOATI	TTI	NOTAPPLIC	CICSUSER	
PRODCICS	CNSL		NOTAPPLIC	INSERVICE	ATI	TTI	NOTAPPLIC	CNSL	
PRODCICS	CO01		NOTAPPLIC	INSERVICE	ATI	TTI	NOTAPPLIC	CICSUSER	
PRODCICS	CO02		NOTAPPLIC	INSERVICE	ATI	TTI	NOTAPPLIC	CICSUSER	
PRODCICS	CO03		NOTAPPLIC	INSERVICE	ATI	TTI	NOTAPPLIC	CICSUSER	
PRODCICS	CO04		NOTAPPLIC	INSERVICE	ATI	TTI	NOTAPPLIC	CICSUSER	
PRODCICS	CO05		NOTAPPLIC	INSERVICE	ATI	TTI	NOTAPPLIC	CICSUSER	
PRODCICS	CO06		NOTAPPLIC	INSERVICE	ATI	TTI	NOTAPPLIC	CICSUSER	
PRODCICS	CO07		NOTAPPLIC	INSERVICE	ATI	TTI	NOTAPPLIC	CICSUSER	
PRODCICS	CO08		NOTAPPLIC	INSERVICE	ATI	TTI	NOTAPPLIC	CICSUSER	
PRODCICS	CO09		NOTAPPLIC	INSERVICE	ATI	TTI	NOTAPPLIC	CICSUSER	
PRODCICS	CO10		NOTAPPLIC	INSERVICE	ATI	TTI	NOTAPPLIC	CICSUSER	
PRODCICS	CO11		NOTAPPLIC	INSERVICE	ATI	TTI	NOTAPPLIC	CICSUSER	
PRODCICS	CO12		NOTAPPLIC	INSERVICE	ATI	TTI	NOTAPPLIC	CICSUSER	
PRODCICS	CO13		NOTAPPLIC	INSERVICE	ATI	TTI	NOTAPPLIC	CICSUSER	

IZE0100I Connected user SYSA to host lnxsalm1.boeblingen.de.ibm.com on port 27283

The 3270 Interface

Left Screenshot:

```

I TE
STATUS: RESULTS - OVERTYPE TO MODIFY
Ter(A000) Tra(CEMT) Pri( 000 ) Pag Ins Ati Tti
  Net(D0010001) Acq Cre
Ter(CBRF)      Pri( 000 ) Pag Ins Ati Tti
  Net(CBRF     ) Rel
Ter(CERR)     Pri( 000 ) Pag Ins      Tti
Ter(CNSL)     Pri( 000 ) Pag Ins Ati Tti
Ter(C001)     Pri( 000 ) Pag Ins Ati Tti
Ter(C002)     Pri( 000 ) Pag Ins Ati Tti
Ter(C003)     Pri( 000 ) Pag Ins Ati Tti
Ter(C004)     Pri( 000 ) Pag Ins Ati Tti
Ter(C005)     Pri( 000 ) Pag Ins Ati Tti
Ter(C006)     Pri( 000 ) Pag Ins Ati Tti
Ter(C007)     Pri( 000 ) Pag Ins Ati Tti
Ter(C008)     Pri( 000 ) Pag Ins Ati Tti
Ter(C009)     Pri( 000 ) Pag Ins Ati Tti
Ter(C010)     Pri( 000 ) Pag Ins Ati Tti
Ter(C011)     Pri( 000 ) Pag Ins Ati Tti
+ Ter(C012)   Pri( 000 ) Pag Ins Ati Tti

RESPONSE: NORMAL                TIME
PF 1 HELP      3 END              7 SBH 8 SF
  
```

Right Screenshot:

```

I TE
RESULT - OVERTYPE TO MODIFY
Terminal(C001)
Transaction()
Priority( 000 )
Pagestatus( Pageable )
Servstatus( Inservice )
Atistatus( Ati )
Ttistatus( Tti )
Purgetype(          )
Netname(           )
Termstatus(        )
Createsess(        )

SYSID=CIC2 APPLID=PRODCICS
TIME: 15.50.54 DATE: 03.23.12
PF 1 HELP      3 END              7 SBH 8 SFH 9 MSG 10 SB 11 SF
  
```

IBM CICS Explorer BETA - C:/CICS-Work

Explorer Edit Project Operations Definitions - Search Window Help

Server: CIC2 CNX0211I Context: PRODCICS. Resource: LOCTRAN. 259 records collected at Apr 4, 2012 6:10:34 PM

Region	Name	Status	Use Count	Program	Priority	Transaction ...	Purgeability	Dumping	Routing
PRODCICS	der	ENABLED	0	CEL4RTO	1	DFHTCL00	NOTPURGEA...	TRANDUMP	STATIC
PRODCICS	disc	ENABLED	0	CLIENT01	1	DFHTCL00	NOTPURGEA...	TRANDUMP	STATIC
PRODCICS	emai	ENABLED	0	CLIENT01	1	DFHTCL00	NOTPURGEA...	TRANDUMP	STATIC
PRODCICS	ftp	ENABLED	0	FTP01	1	DFHTCL00	NOTPURGEA...	TRANDUMP	STATIC
PRODCICS	iccf	ENABLED	0	DTSICCF	1	DFHTCL00	NOTPURGEA...	TRANDUMP	STATIC
PRODCICS	lpr	ENABLED	0	CLIENT01	1	DFHTCL00	NOTPURGEA...	TRANDUMP	STATIC
PRODCICS	newc	ENABLED	0	EDCCNEWC	1	DFHTCL00	NOTPURGEA...	TRANDUMP	STATIC
PRODCICS	ping	ENABLED	0	CLIENT01	1	DFHTCL00	NOTPURGEA...	TRANDUMP	STATIC
PRODCICS	rexe	ENABLED	0	CLIENT01	1	DFHTCL00	NOTPURGEA...	TRANDUMP	STATIC
PRODCICS	ropc	ENABLED	0	EDCYCROP	1	DFHTCL00	NOTPURGEA...	TRANDUMP	STATIC
PRODCICS	teln	ENABLED	0	TELNET01	1	DFHTCL00	NOTPURGEA...	TRANDUMP	STATIC
PRODCICS	trac	ENABLED	0	CLIENT01	1	DFHTCL00	NOTPURGEA...	TRANDUMP	STATIC
PRODCICS	APVU	ENABLED	0	INWPCCOM	20	DFHTCL00	PURGEABLE	TRANDUMP	STATIC
PRODCICS	ARPS	ENABLED	0	DFH\$ARPS	1	DFHTCL00	NOTPURGEA...	TRANDUMP	STATIC
PRODCICS	CATA	ENABLED	1	DFHZATA	255	DFHTCL00	PURGEABLE	TRANDUMP	STATIC
PRODCICS	CATD	ENABLED	1	DFHZATD	255	DFHTCL00	PURGEABLE	TRANDUMP	STATIC
PRODCICS	CATR	ENABLED	1	DFHZATR	255	DFHTCL00	NOTPURGEA...	TRANDUMP	STATIC
PRODCICS	CCIN	ENABLED	0	DFHZCN1	254	DFHCOMCL	PURGEABLE	TRANDUMP	STATIC
PRODCICS	CDTS	ENABLED	0	DFHZATS	255	DFHTCL00	PURGEABLE	TRANDUMP	STATIC
PRODCICS	CEBR	ENABLED	0	DFHEDFBR	1	DFHTCL00	NOTPURGEA...	TRANDUMP	STATIC
PRODCICS	CECI	ENABLED	0	DFHECIP	1	DFHTCL00	PURGEABLE	TRANDUMP	STATIC
PRODCICS	CECS	ENABLED	0	DFHECSP	1	DFHTCL00	PURGEABLE	TRANDUMP	STATIC
PRODCICS	CEDA	ENABLED	0	DFHEDAP	1	DFHTCL00	PURGEABLE	TRANDUMP	STATIC
PRODCICS	CEDB	ENABLED	0	DFHEDAP	1	DFHTCL00	PURGEABLE	TRANDUMP	STATIC
PRODCICS	CEDC	ENABLED	0	DFHEDAP	1	DFHTCL00	PURGEABLE	TRANDUMP	STATIC
PRODCICS	CEDF	ENABLED	0	DFHEDFP	1	DFHTCL00	PURGEABLE	TRANDUMP	STATIC
PRODCICS	CEDX	ENABLED	0	DFHEDFP	1	DFHTCL00	PURGEABLE	TRANDUMP	STATIC
PRODCICS	CEGN	ENABLED	0	DFHCEGN	255	DFHTCL00	PURGEABLE	TRANDUMP	STATIC
PRODCICS	CEHP	ENABLED	0	DFHCHS	1	DFHTCL00	NOTPURGEA...	TRANDUMP	STATIC
PRODCICS	CEHS	ENABLED	0	DFHCHS	1	DFHTCL00	NOTPURGEA...	TRANDUMP	STATIC
PRODCICS	CEMS	ENABLED	0	DFHEMSP	1	DFHTCL00	NOTPURGEA...	TRANDUMP	STATIC
PRODCICS	CEMT	ENABLED	0	DFHEMTP	255	DFHTCL00	NOTPURGEA...	TRANDUMP	STATIC
PRODCICS	CEOS	ENABLED	0	DFHEMSP	1	DFHTCL00	NOTPURGEA...	TRANDUMP	STATIC
PRODCICS	CEOT	ENABLED	0	DFHEOTP	255	DFHTCL00	PURGEABLE	TRANDUMP	STATIC
PRODCICS	CEPW	ENABLED	0	DFHPSOP	254	DFHTCL00	NOTPURGEA...	TRANDUMP	STATIC
PRODCICS	CESC	ENABLED	0	DFHCESC	255	DFHTCL00	NOTPURGEA...	TRANDUMP	STATIC
PRODCICS	CESF	ENABLED	0	DFHSFP	1	DFHTCL00	PURGEABLE	TRANDUMP	STATIC
PRODCICS	CESN	ENABLED	0	DFHSNP	1	DFHTCL00	PURGEABLE	TRANDUMP	STATIC
PRODCICS	CEST	ENABLED	0	DFHESTP	255	DFHTCL00	PURGEABLE	TRANDUMP	STATIC
PRODCICS	CETR	ENABLED	0	DFHCETRA	255	DFHTCL00	NOTPURGEA...	TRANDUMP	STATIC
PRODCICS	CFTS	ENABLED	0	DFHZATS	255	DFHTCL00	NOTPURGEA...	TRANDUMP	STATIC

IZE0100I Connected user SYSA to host Inxsalm1.boeblingen.de.ibm.com on port 27283

IBM CICS Explorer BETA - C:/CICS-Work

Explorer Edit Project Operations Definitions - Search Window Help

Server: CIC2 CNX0211I Context: PRODCICS, Resource: PROGRAM, 1,601 records collected at Apr 4, 2012 6:13:20 PM

Region	Name	Status	Use Count	Concurrent Use...	Language	Share Status	CEDF Status	NEWCOPY Statu
PRODCICS	\$EDCTCPM	✓ ENABLED	0	0	C	N/A	CEDF	NOTREQUIRED
PRODCICS	\$EDCTCPV	✓ ENABLED	0	0	C	N/A	CEDF	NOTREQUIRED
PRODCICS	ARXITCPU	✓ ENABLED	0	0	ASSEMBLER	N/A	CEDF	NOTREQUIRED
PRODCICS	BSTADMII	✓ ENABLED	0	0	ASSEMBLER	N/A	CEDF	NOTREQUIRED
PRODCICS	CEEBINT	✓ ENABLED	1	1	ASSEMBLER	N/A	CEDF	NOTREQUIRED
PRODCICS	CEEBNATX	✓ ENABLED	0	0	ASSEMBLER	N/A	CEDF	NOTREQUIRED
PRODCICS	CEECBLDY	✓ ENABLED	0	0	ASSEMBLER	N/A	CEDF	NOTREQUIRED
PRODCICS	CEECCICS	✓ ENABLED	1	1	ASSEMBLER	N/A	CEDF	NOTREQUIRED
PRODCICS	CEECDATX	✓ ENABLED	0	0	ASSEMBLER	N/A	CEDF	NOTREQUIRED
PRODCICS	CEECMI	✓ ENABLED	0	0	ASSEMBLER	N/A	CEDF	NOTREQUIRED
PRODCICS	CEECOPT	✓ ENABLED	1	1	ASSEMBLER	N/A	CEDF	NOTREQUIRED
PRODCICS	CEECRHP	✓ ENABLED	0	0	ASSEMBLER	N/A	CEDF	NOTREQUIRED
PRODCICS	CEECKITA	✓ ENABLED	1	1	ASSEMBLER	N/A	CEDF	NOTREQUIRED
PRODCICS	CEECKTAN	✓ ENABLED	1	1	ASSEMBLER	N/A	CEDF	NOTREQUIRED
PRODCICS	CEECZST	✓ ENABLED	0	0	ASSEMBLER	N/A	CEDF	NOTREQUIRED
PRODCICS	CEEDATE	✓ ENABLED	0	0	ASSEMBLER	N/A	CEDF	NOTREQUIRED
PRODCICS	CEEDATM	✓ ENABLED	0	0	ASSEMBLER	N/A	CEDF	NOTREQUIRED
PRODCICS	CEEDAYS	✓ ENABLED	0	0	ASSEMBLER	N/A	CEDF	NOTREQUIRED
PRODCICS	CEEDCOD	✓ ENABLED	0	0	ASSEMBLER	N/A	CEDF	NOTREQUIRED
PRODCICS	CEEDSHP	✓ ENABLED	0	0	ASSEMBLER	N/A	CEDF	NOTREQUIRED
PRODCICS	CEEDYWK	✓ ENABLED	0	0	ASSEMBLER	N/A	CEDF	NOTREQUIRED
PRODCICS	CEENV	✓ ENABLED	0	0	ASSEMBLER	N/A	CEDF	NOTREQUIRED
PRODCICS	CEEEV000	✓ ENABLED	0	0	NOTDEFINED	N/A	CEDF	REQUIRED
PRODCICS	CEEEV001	✓ ENABLED	0	0	NOTDEFINED	N/A	CEDF	REQUIRED
PRODCICS	CEEEV002	✓ ENABLED	0	0	NOTDEFINED	N/A	CEDF	REQUIRED
PRODCICS	CEEEV003	✓ ENABLED	1	1	ASSEMBLER	N/A	CEDF	NOTREQUIRED
PRODCICS	CEEEV004	✓ ENABLED	0	0	NOTDEFINED	N/A	CEDF	REQUIRED
PRODCICS	CEEEV005	✓ ENABLED	1	1	ASSEMBLER	N/A	CEDF	NOTREQUIRED
PRODCICS	CEEEV006	✓ ENABLED	0	0	NOTDEFINED	N/A	CEDF	REQUIRED
PRODCICS	CEEEV007	✓ ENABLED	0	0	NOTDEFINED	N/A	CEDF	REQUIRED
PRODCICS	CEEEV008	✓ ENABLED	0	0	NOTDEFINED	N/A	CEDF	REQUIRED
PRODCICS	CEEEV009	✓ ENABLED	0	0	NOTDEFINED	N/A	CEDF	REQUIRED
PRODCICS	CEEEV010	✓ ENABLED	1	1	ASSEMBLER	N/A	CEDF	NOTREQUIRED
PRODCICS	CFFFV011	✓ FNARI FD	0	0	NOTDFINFD	N/A	CFDF	RFOI ITRFD

IZE01001 Connected user SYSA to host Inxsalm1.boeblingen.de.ibm.com on port 27283

IBM CICS Explorer BETA - C:/CICS-Work

Explorer Edit Project Operations Definitions - Search Window Help

Regions TCP/IP S ISC/MR Terminal Transact Transact Program Tasks Files Interval TD Queu TS Queu

Server: CIC2 CNX0211I Context: PRODCICS, Resource: LOCFILE. 14 records collected at Apr 4, 2012 6:14:54 PM

Region	Name	Status	Open Status	Add	Browse	Delete	Read	Update	LSR Pool ID	DS Name
PRODCICS	BSTCNTL	✓ ENABLED	CLOSED	ADDABLE	BROWSABLE	DELETABLE	READABLE	UPDATABLE	0	VSE.BSTCN...
PRODCICS	DFHCSD	UNENABLED	CLOSED	ADDABLE	BROWSABLE	DELETABLE	READABLE	UPDATABLE	1	CICS.CSD
PRODCICS	EZACACH	✓ ENABLED	CLOSED	ADDABLE	BROWSABLE	DELETABLE	READABLE	UPDATABLE	1	
PRODCICS	EZACONF	✓ ENABLED	CLOSED	ADDABLE	BROWSABLE	DELETABLE	READABLE	NOTUPDAT...	1	
PRODCICS	IESCNTL	✓ ENABLED	OPEN	ADDABLE	BROWSABLE	DELETABLE	READABLE	UPDATABLE	1	VSE.CONTR...
PRODCICS	IESLDUM	✓ ENABLED	CLOSED	ADDABLE	BROWSABLE	DELETABLE	READABLE	UPDATABLE	1	VSE.LDAP...
PRODCICS	IESPRB	✓ ENABLED	OPEN	ADDABLE	NOTBROW...	NOTDELET...	READABLE	UPDATABLE	1	CICS2.ONL...
PRODCICS	IESROUT	✓ ENABLED	OPEN	ADDABLE	BROWSABLE	DELETABLE	READABLE	UPDATABLE	1	VSE.MESSA...
PRODCICS	IESTRFL	✓ ENABLED	OPEN	NOTADDABLE	NOTBROW...	NOTDELET...	READABLE	NOTUPDAT...	1	VSE.TEXT.R...
PRODCICS	INWFILE	✓ ENABLED	CLOSED	ADDABLE	BROWSABLE	DELETABLE	READABLE	UPDATABLE	1	PC.HOST.T...
PRODCICS	RFSDIR1	✓ ENABLED	CLOSED	ADDABLE	BROWSABLE	DELETABLE	READABLE	UPDATABLE	1	CICREX.FP...
PRODCICS	RFSDIR2	✓ ENABLED	CLOSED	ADDABLE	BROWSABLE	DELETABLE	READABLE	UPDATABLE	1	CICREX.FP...
PRODCICS	RFSPOL1	✓ ENABLED	CLOSED	ADDABLE	BROWSABLE	DELETABLE	READABLE	UPDATABLE	1	CICREX.FP...
PRODCICS	RFSPOL2	✓ ENABLED	CLOSED	ADDABLE	BROWSABLE	DELETABLE	READABLE	UPDATABLE	1	CICREX.FP...

IZE0100I Connected user SYSA to host lnxsalm1.boeblingen.de.ibm.com on port 27283

lnx

More Information

... on VSE home page: <http://ibm.com/vse>

- **Hints and Tips for z/VSE V4.3:**
 - <ftp://public.dhe.ibm.com/eserver/zseries/zos/vse/pdf3/zvse43/hintbmm2.pdf>

- 64 bit virtual information:
 - IBM z/VSE Extended Addressability, Version 5 Release 1
 - IBM z/VSE System Macro Reference, Version 5 Release 1

- CICS TS: <http://www-03.ibm.com/systems/z/os/zvse/products/cics.html>

- IBM Redbooks:
 - Introduction to the New Mainframe: z/VSE Basics
<http://www.redbooks.ibm.com/abstracts/sg247436.html?Open>

 - **Security on IBM z/VSE – new update available**
<http://www.redbooks.ibm.com/Redbooks.nsf/RedbookAbstracts/sg247691.html?Open>

 - z/VSE Using DB2 on Linux for System z
<http://www.redbooks.ibm.com/abstracts/sg247690.html?Open>