

# *z/VM Product Update*

*Romney White*

*System z Architecture and Technology*



## Trademarks

The following are trademarks of the International Business Machines Corporation in the United States and/or other countries.

**IBM\***  
**IBM Logo\***

\* Registered trademarks of IBM Corporation

The following are trademarks or registered trademarks of other companies.

Adobe, the Adobe logo, PostScript, and the PostScript logo are either registered trademarks or trademarks of Adobe Systems Incorporated in the United States, and/or other countries.

IT Infrastructure Library is a registered trademark of the Central Computer and Telecommunications Agency which is now part of the Office of Government Commerce.

Intel, Intel logo, Intel Inside, Intel Inside logo, Intel Centrino, Intel Centrino logo, Celeron, Intel Xeon, Intel SpeedStep, Itanium, and Pentium are trademarks or registered trademarks of Intel Corporation or its subsidiaries in the United States and other countries.

Linux is a registered trademark of Linus Torvalds in the United States, other countries, or both.

Microsoft, Windows, Windows NT, and the Windows logo are trademarks of Microsoft Corporation in the United States, other countries, or both.

ITIL is a registered trademark, and a registered community trademark of the Office of Government Commerce, and is registered in the U.S. Patent and Trademark Office.

UNIX is a registered trademark of The Open Group in the United States and other countries.

Java and all Java-based trademarks and logos are trademarks or registered trademarks of Oracle and/or its affiliates.

Cell Broadband Engine is a trademark of Sony Computer Entertainment, Inc. in the United States, other countries, or both and is used under license therefrom.

Linear Tape-Open, LTO, the LTO Logo, Ultrium, and the Ultrium logo are trademarks of HP, IBM Corp. and Quantum in the U.S. and other countries.

\* All other products may be trademarks or registered trademarks of their respective companies.

### Notes:

Performance is in Internal Throughput Rate (ITR) ratio based on measurements and projections using standard IBM benchmarks in a controlled environment. The actual throughput that any user will experience will vary depending upon considerations such as the amount of multiprogramming in the user's job stream, the I/O configuration, the storage configuration, and the workload processed. Therefore, no assurance can be given that an individual user will achieve throughput improvements equivalent to the performance ratios stated here.

IBM hardware products are manufactured from new parts, or new and serviceable used parts. Regardless, our warranty terms apply.

All customer examples cited or described in this presentation are presented as illustrations of the manner in which some customers have used IBM products and the results they may have achieved. Actual environmental costs and performance characteristics will vary depending on individual customer configurations and conditions.

This publication was produced in the United States. IBM may not offer the products, services or features discussed in this document in other countries, and the information may be subject to change without notice. Consult your local IBM business contact for information on the product or services available in your area.

All statements regarding IBM's future direction and intent are subject to change or withdrawal without notice, and represent goals and objectives only.

Information about non-IBM products is obtained from the manufacturers of those products or their published announcements. IBM has not tested those products and cannot confirm the performance, compatibility, or any other claims related to non-IBM products. Questions on the capabilities of non-IBM products should be addressed to the suppliers of those products.

Prices subject to change without notice. Contact your IBM representative or Business Partner for the most current pricing in your geography.

---

## Agenda

- Pricing review
- Status update for older releases
- Introducing z/VM V6.2
- IBM Statements of Direction
- New functions shipped as service

## z/VM Pricing

- z/VM pricing consists of:
  - A one-time charge (OTC) per value unit
  - An annual charge for Service & Support, per value unit
- Number of value units is determined by number of engines, shown below on left
- Prices are set per value unit, relative prices are illustrated below on right
- SSI feature includes LGR and is priced in line with the RACF feature

z/VM Value Unit Schedule	
Number of Engines	Value Units per Engine
1 to 3	10
4 to 6	9
7 to 9	8
10 to 12	7
13 to 16	6
17 to 20	5
21 to 25	4
26 and above	3

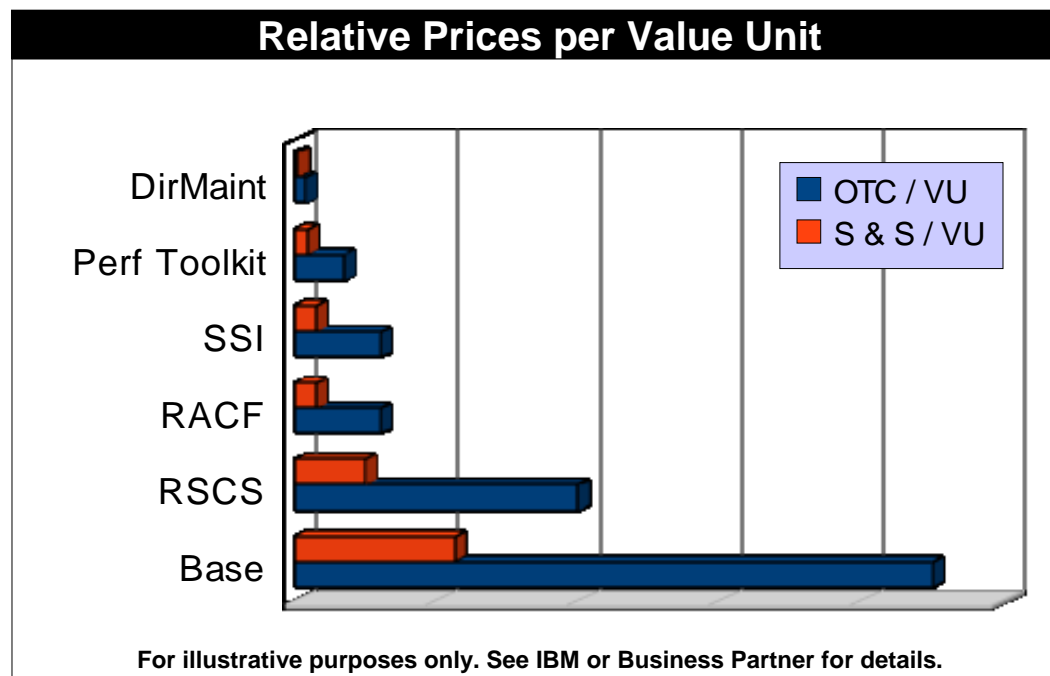

## VM/370

- Happy Birthday, VM/370!
  - 5749-010 announced as a supported commercial product on August 2, 1972
  - Formally withdrawn April 24, 1989
  - <http://www.vm.ibm.com/vm40bday.html>



## z/VM Version 5 Release 4



- The last release of z/VM to support IBM System z9 and older processors
- **No longer available** as of March 12, 2012
- End of Service has been extended to December 31, 2014 or end of IBM service for System z9, whichever is *later*
  - Was September 30, 2013
  - Later, but not *too* much later!



## z/VM Version 6 Security Certification Plans

- Common Criteria (ISO/IEC 15408)
  - Statement of Direction issued 22 July 2010
  - **Evaluation in progress (BSI-DSZ-CC-0752)**
  - Security Target: Operating System Protection Profile (OSPP) at EAL 4+
    - Virtualization extension
    - Labeled Security extension
  
- Federal Information Protection Standard (FIPS) 140-2
  - z/VM 6.1 System SSL is FIPS 140-2 Validated<sup>TM</sup>
  - Enablement requirements for certificate database and servers
    - <http://csrc.nist.gov/groups/STM/cmvp/documents/140-1/1401val2012.htm#1735>
  
- z/VM 6.2 is designed to conform to both Common Criteria and FIPS 140-2 evaluation requirements



<sup>TM</sup> A Certification Mark of NIST, which does not imply product endorsement by NIST, the U.S. or Canadian Governments.

## z/VM Release Status Summary

z/VM Level		GA	End of Service	End of Marketing	Minimum Processor Level	Security Level
Ver 6	Rel 2	12 / 2011	4 / 2015		z10	-
	Rel 1	10 / 2009	12 / 2014	12 / 2011	z10	EAL 4+ <sup>[1]</sup> OSPP-LS
Ver 5	Rel 4	9 / 2008	9 / 2013 <sup>[2]</sup>	3 / 2012	z800, z900	-
	Rel 3	6 / 2007	9 / 2010	9 / 2010	z800, z900	EAL 4+ CAPP/LSP

Marketed & Serviced

Serviced, but not Marketed

End of Service & Marketing

<sup>[1]</sup> Currently in evaluation

<sup>[2]</sup> Or later (Announced August 7, 2012)



## z/VM Version 6 Release 2



- Announced **October 12, 2011**
- Generally available **December 2, 2011**
- End of service **April 30, 2015**
- Major changes include:
  - Single System Image
  - Live Guest Relocation
  - Turnkey support for Unified Resource Manager
- Replaced z/VM V6.1
  - No longer available
  - End of service April 2013

## Single System Image Feature Clustered Hypervisor with Live Guest Relocation

- Provided as an optional priced feature.
- Connect up to four z/VM systems as members of a Single System Image (SSI) cluster
- Provides a set of shared resources for member systems and their hosted virtual machines
- Cluster members can be run on the same or different System z servers
- Simplifies systems management of a multi-z/VM environment
  - Single user directory
  - Cluster management from any member
    - Apply maintenance to all members in the cluster from one location
    - Issue commands from one member to operate on another
  - Built-in cross-member capabilities
  - Resource coordination and protection of network and disks

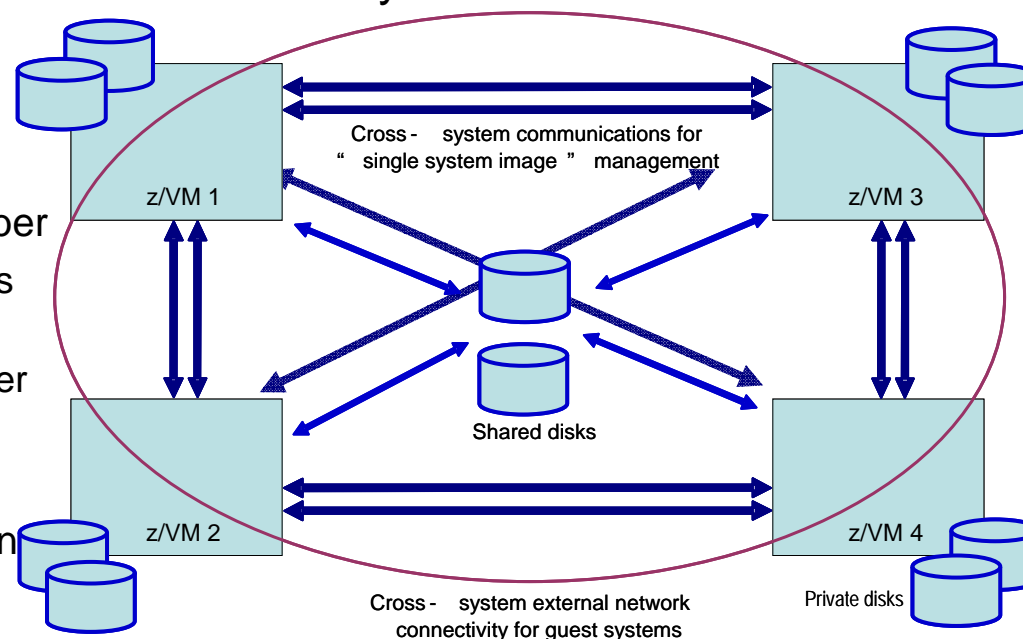

---

## SSI Cluster Management – Features for Greater Reliability

- Cross-checking of configuration details as members join cluster and as resources are used:
  - SSI membership definition and identity
  - Consistent definition of shared spool volumes
  - Compatible virtual network configurations (MAC address ranges, VSwitch definitions)
  
- Cluster-wide policing of resource access:
  - Volume ownership marking to prevent dual use
  - Coordinated minidisk link checking
  - Autonomic minidisk cache management
  - Single logon enforcement
  
- Communications failure “locks down” future resource allocations until resolved
  
- Comprehensive checking for resource and machine feature compatibility during relocation:
  - Adjustment of “virtual architecture level” to support customer relocation policy

## Single System Image Feature Clustered Hypervisor with Live Guest Relocation

- Dynamically move Linux guests from one member to another with Live Guest Relocation
  - Reduce planned outages
  - Enhance workload management
  - Non-disruptively move work to available system resources and non-disruptively move system resources to work
- When combined with Capacity Upgrade on Demand, Capacity Backup on Demand, and Dynamic Memory Upgrade, you will get the best of both worlds

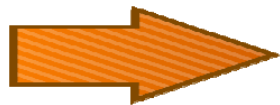

Bring additional resources to the workload!

Move the workload to the resources!



---

## Safe Guest Relocation

- Eligibility checks done multiple times throughout the relocation process
  
- Check more than just eligibility to move the virtual machine, but also check if it is “safe” to move
  - Overrides are available
  
- Checks for:
  - Does virtual machine really have access to all the same resources and functions?
  - Will moving the virtual machine over commit resources to the point of jeopardizing other workload on the destination system?
  
- Pacing logic to minimize impact to other work in more memory constrained environments

---

## Single System Image Feature Clustered Hypervisor with Live Guest Relocation

- Unified Resource Manager *does not* support SSI and LGR
  
- IBM Systems Director *does not* support SSI and LGR
  
- Suggested best practice is to not combine SSI and LGR with the above offerings
  - Work with your IBM Sales Team, IBM Lab Services, or z/VM Development Lab to determine which technologies are most critical to your environment and business.

## *Stages of a Live Guest Relocation*

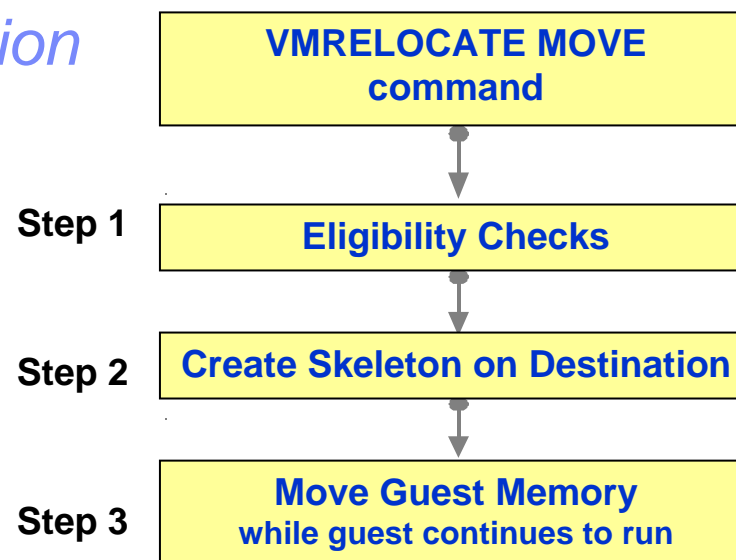

## LGR, High-Level View of Memory Move

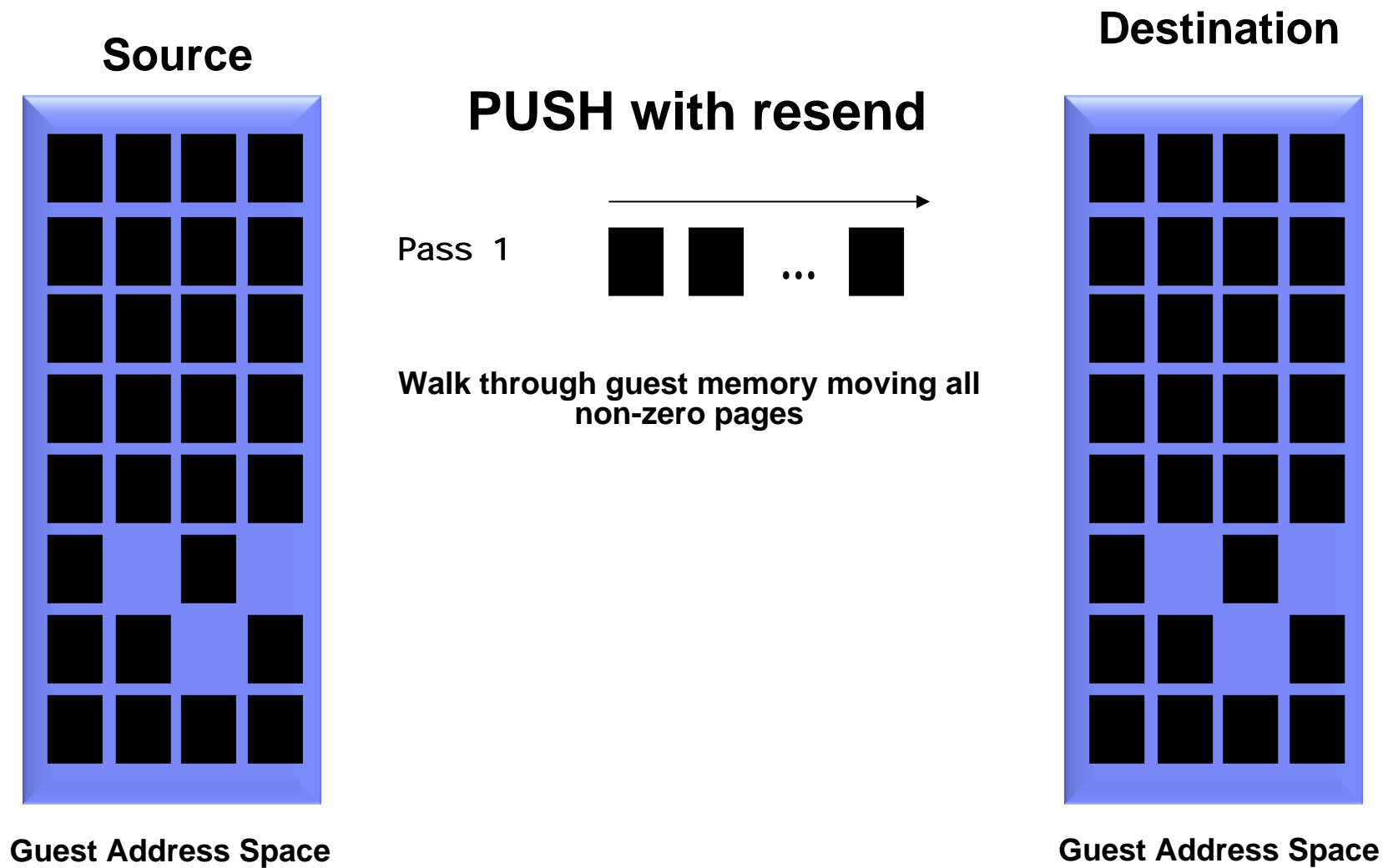



# LGR, High-Level View of Memory Move

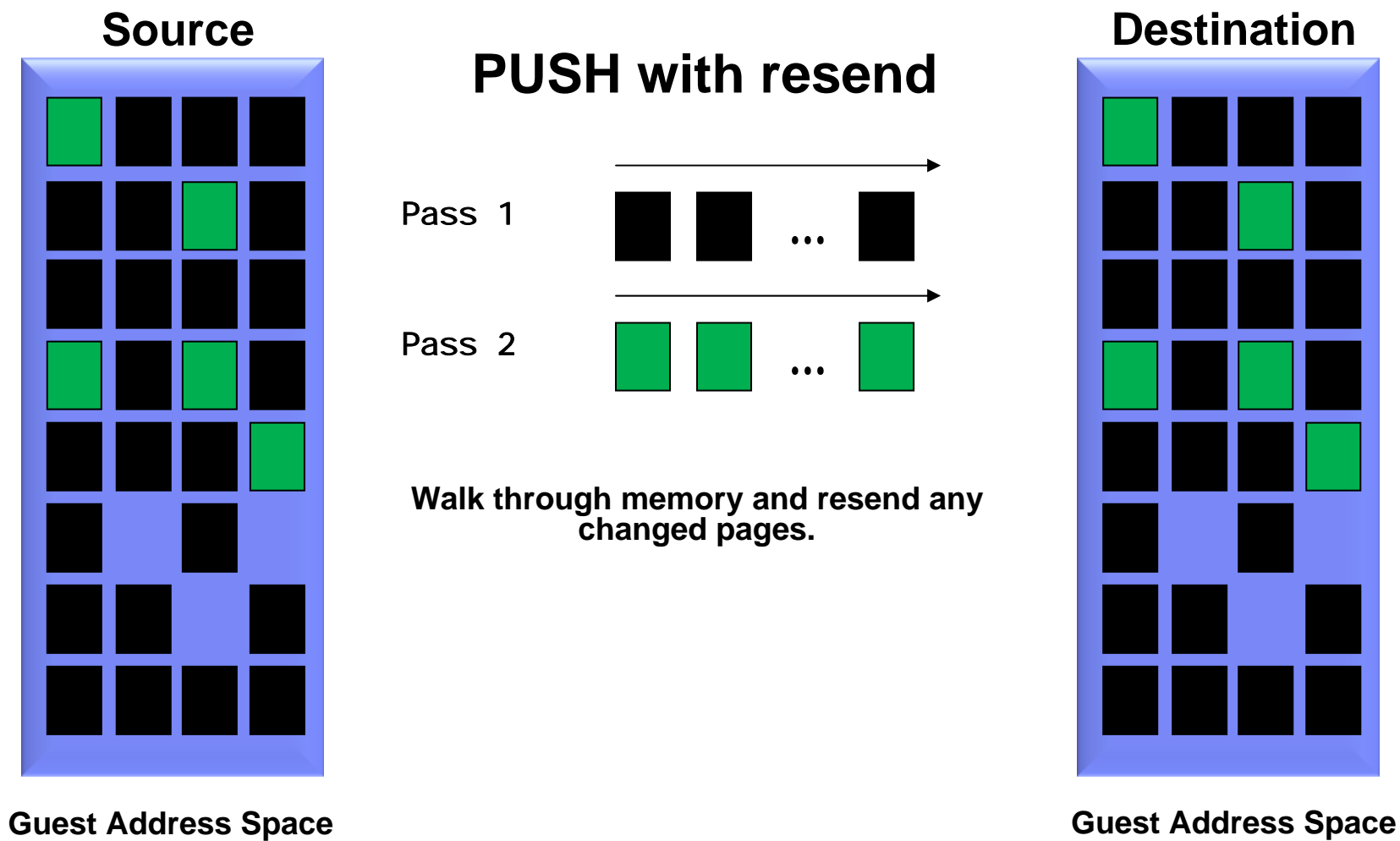

# LGR, High-Level View of Memory Move

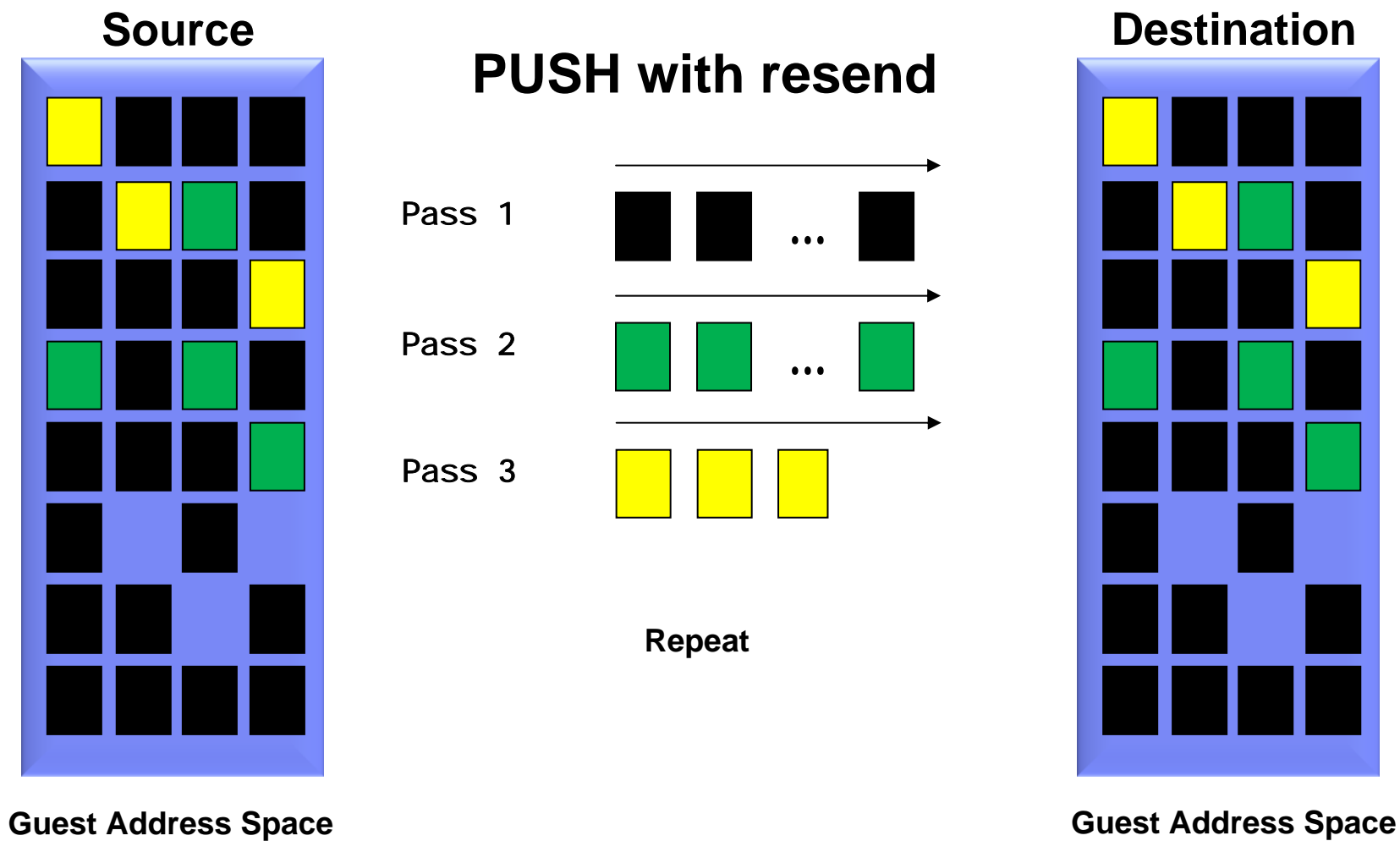

# LGR, High-Level View of Memory Move

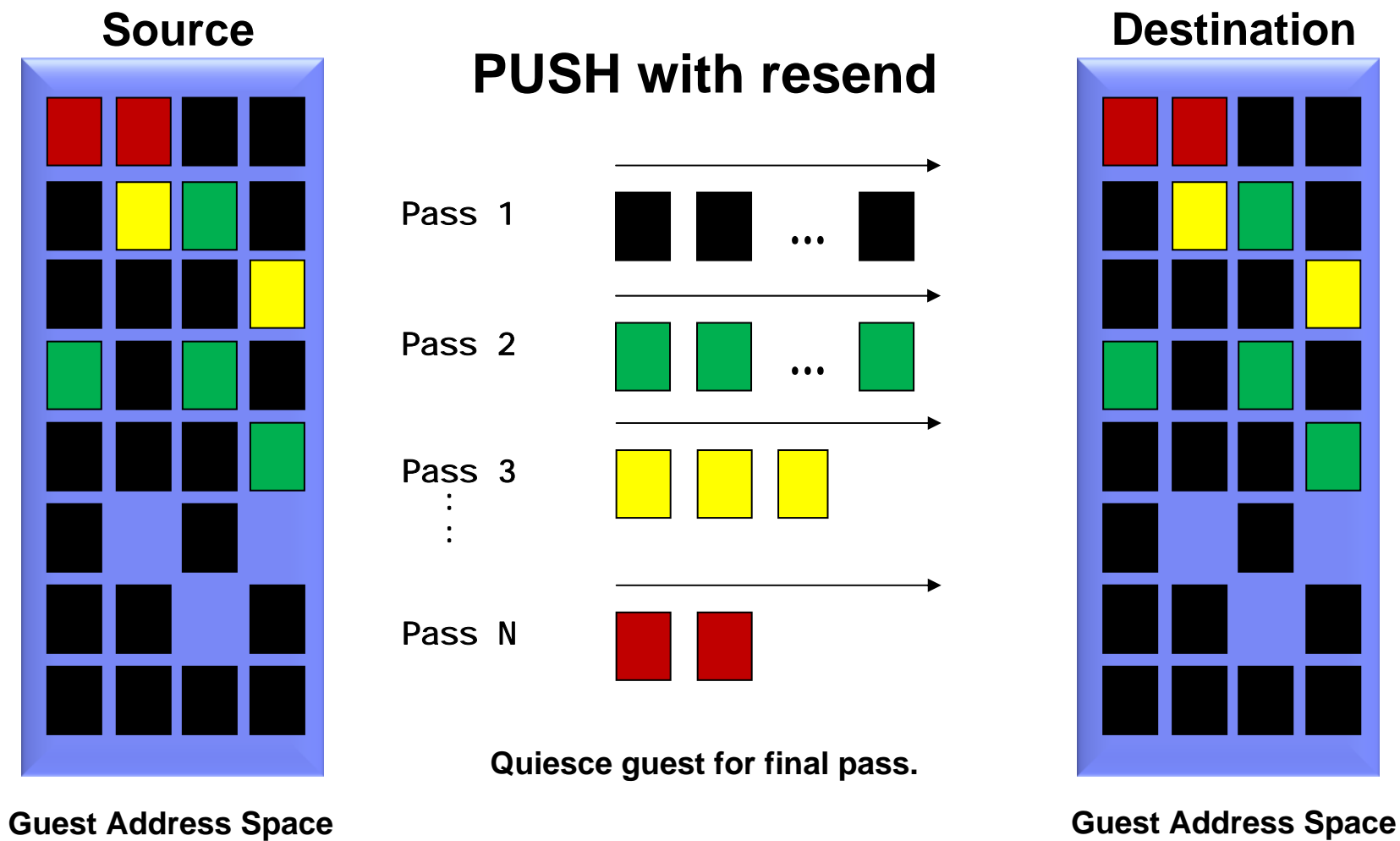

## Stages of a Live Guest Relocation

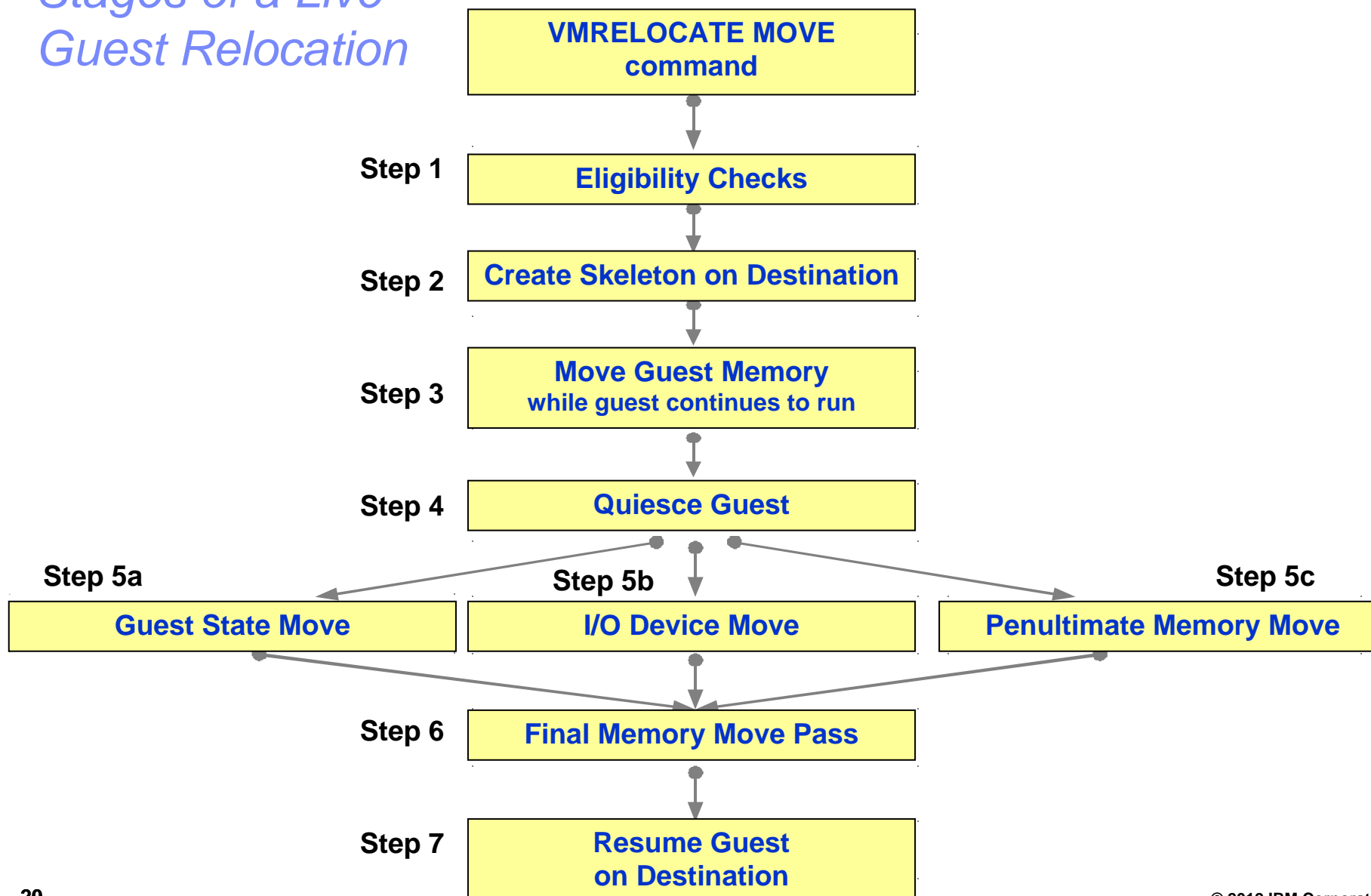

---

## *Live Guest Relocation*

- ***New SMAPI interfaces***
  - VMRELOCATE
  - VMRELOCATE\_Image\_Attributes
  - VMRELOCATE\_Modify
  
- ***Other Interfaces of note:***
  - \*VMEVENT
  - \*MONITOR
  - \*ACCOUNT
  
- ***New CP Exit Points***

---

## SSI & LGR Considerations

- ***Do your VM vendor products support SSI & LGR?***
  - Guest Relocation?
  - Charge back models?
  - Licensing?
  
- ***What are your vendors' positions on their products when running in guests that are relocated?***
  - Remember quiesce time

## *z/VM Storage Support*

### ▪ ***z/VM 6.2 supports***

- **DS8000 Series**
  - DS8100, DS8300, DS8700, DS8800
- **DS6000 Series**
- **XIV**
- **IBM San Volume Controller (SVC)**
- **IBM Storwize V7000**
  - See [http://www.ibm.com/support/docview.wss?uid=ssg1S1003703#\\_zvm](http://www.ibm.com/support/docview.wss?uid=ssg1S1003703#_zvm)
- **As well as many of the older storage devices**

### ▪ ***The System Storage Interoperation Center (SSIC) support page has some omissions of the above support***

- **We are working to correct these**
- <http://www.ibm.com/systems/support/storage/ssic/interoperability.wss>

### ▪ ***The z/VM 6.2 General Information Manual has additional information, but had not been updated for Storwize, see URL above for requirements.***

## *z/VM System Management*

- ***Operations Manager for z/VM V1.4***
  - Facilitates automated operations
  - Monitor, view, and interact with consoles without logging on to service machines or Linux guests
  - Take actions based on service machine console messages and other system events
  - Schedule events for immediate execution or on a regular schedule
- ***OMEGAMON XE on z/VM and Linux V4.2***
  - Performance monitoring of z/VM and Linux guests
  - Part of the Tivoli Management Services, including Tivoli Enterprise Portal
  - Uses IBM Performance Toolkit for VM as its data source
- ***Backup and Restore Manager for z/VM V1.2***
  - Backup and restore file level data for CMS minidisks and Shared File System
  - Backup and restore images of Linux guests and/or z/VM volumes
    - Use Tivoli Storage Manager for file level backup and restore of Linux data
- ***Tape Manager for z/VM V1.3***
  - Manage tapes: retention, access control, data security erase
  - Manage devices: share with other z/VM and non-z/VM systems
  - Manage mount requests for ATL, VTS, and manual mount devices
- ***zSecure Manager for RACF z/VM V1.11.1***
  - Automate complex, time consuming z/VM security management tasks
  - Quickly identify and prevent problems in RACF
  - Create comprehensive audit trails
- ***Archive Manager for z/VM V1.1***
  - Users and administrators manage disk space more efficiently and effectively
  - Archive infrequently used or large files to tape or other disk



**All support  
z/VM 6.2!**



# HiperSocket VSWITCH Integration with zEnterprise IEDN

Available: April 13, 2012

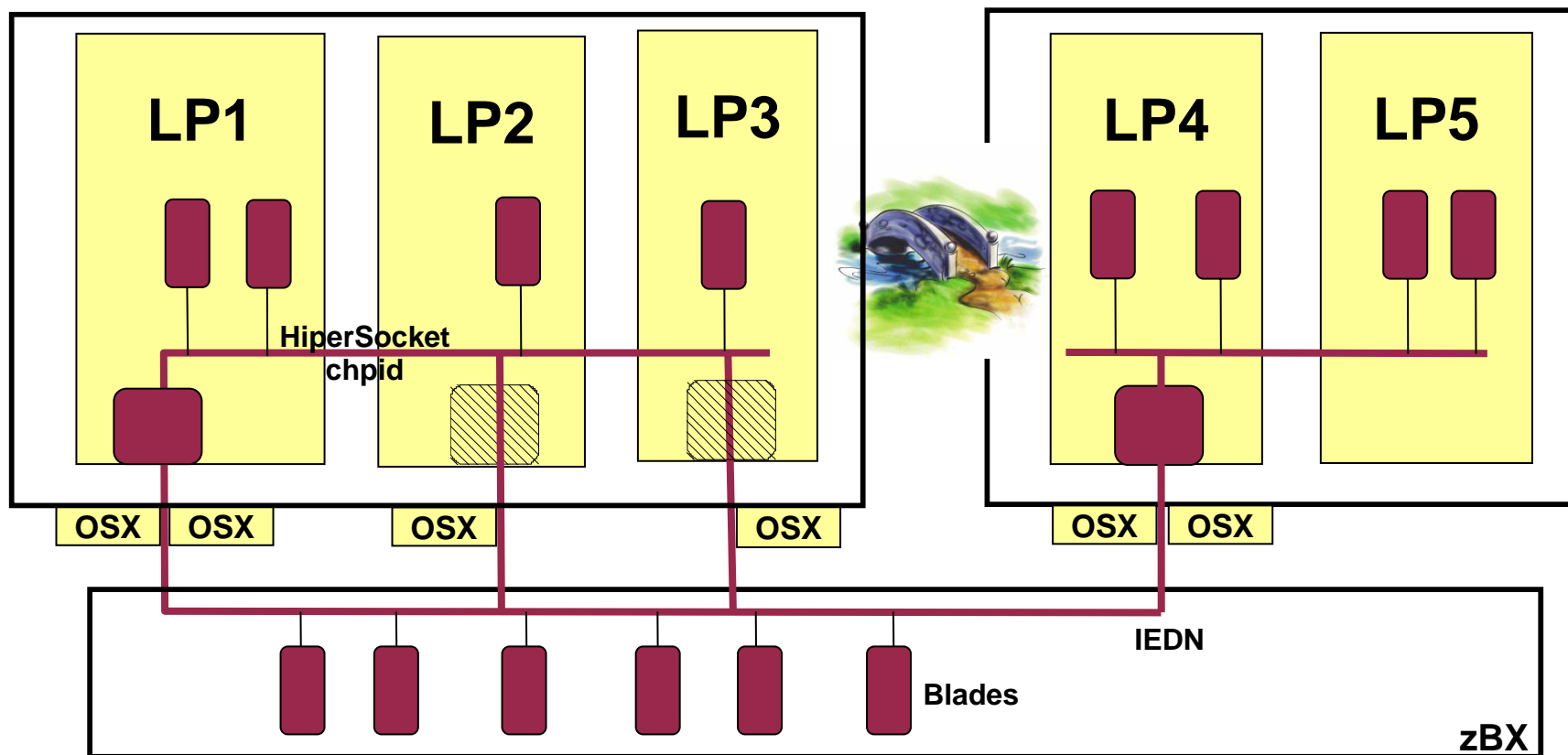

- Built-in failover and failback
- Bridge new IQDX chpid to OSX chpid
- Also works for IQD to OSD

- Same or different LPAR
- One active bridge per CEC
- PMTU simulation

## HiperSocket VSWITCH Integration

*Available: April 13, 2012*

- Virtual Switch bridge between Ethernet LAN and HiperSockets
  - zEnterprise IEDN (OSX) or OSD connections
    - Original Statement of Direction only mentioned IEDN
  - Guests can use simulated OSA or dedicated HiperSockets
  - VLAN aware
  - One HiperSocket chpid only
- Full redundancy
  - Up to 5 bridges per CEC
  - One bridge per LPAR
  - Automatic takeover
  - Optionally designate one “primary”
    - Primary will perform “takeback” when it comes up
  - Each bridge can have more than one OSA uplink
- CP: VM65042 PTF UM33691
- TCP/IP: PM46988 PTF UK77220

---

## High Performance FICON

*Available: April 13, 2012*

- Enable guests to use High Performance FICON for System z (zHPF)
  - Different I/O model
  - Single and multiple track I/O
  - CP APAR VM65041 PTF UM33646
  - DVF APAR VM65144 PTF UM33647
- Requires host and control unit compatibility
  - Consult a storage specialist for details
- z/OS and Linux provide exploitation
- Performance results available at:
  - <http://www.vm.ibm.com/perf/reports/zvm/html/620jb.html>

## VSWITCH: Multiple access ports per guest

- One or more virtual ports on a VSWITCH are reserved for a guest
- Ports are associated with a VLAN – implicit authorization (exc. RACF)
- Authorization changes take effect immediately
- Eliminates need for VLAN-aware guests

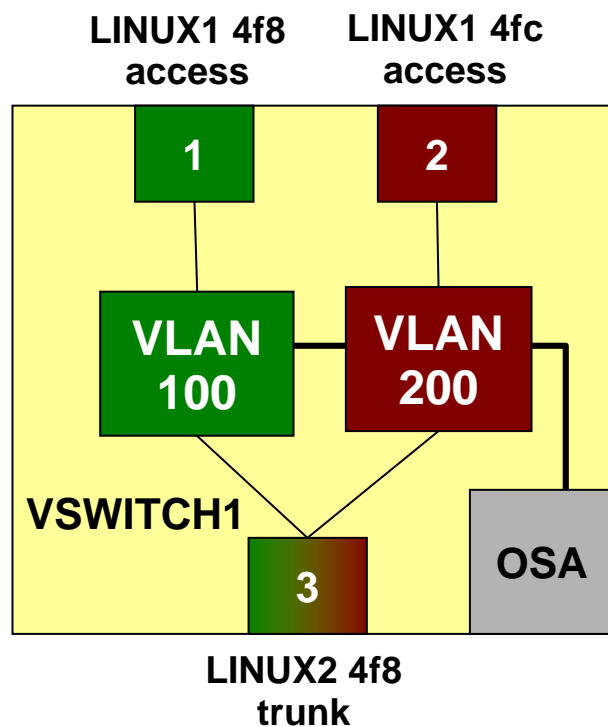

```
define vswitch vswitch1 portbased vlan aware native none
set vswitch vswitch1 portnumber 1 userid LINUX1
set vswitch vswitch1 portnumber 2 userid LINUX1
set vswitch vswitch1 portnumber 3 userid LINUX2 porttype trunk
set vswitch vswitch1 vlanid 100 add 1 3
set vswitch vswitch1 vlanid 200 add 2 3
```

```
USER1:
Couple 4f8 to system vswitch1 portnum 1
Couple 4fc to system vswitch1 portnum 2
```

```
USER2:
Couple 4f8 to system vswitch1 [portnum 3]
```

**Switch port number not available on NICDEF – use  
COMMAND COUPLE in the directory.**

---

## Scalability and Performance Enhancements

Available by PTF to prior releases where shown

- Reduction of memory and CPU resources required to manage larger memory sizes
- Control of the guest page re-ordering process, improving the performance characteristics of guests with large memory footprints (VM64774)
- Reduced system overhead of guest page release function, thereby helping to increase guest throughput (VM64715)
- Improved contiguous frame coalescing algorithms help to increase system throughput (VM64795)

---

## Scalability and Performance Enhancements

Available by PTF to prior releases where shown

- More accurate scheduling algorithm for guests that have LIMITHARD shares (VM64721)
- Reduce LPAR suspend time by reducing the number of DIAGNOSE 0x9C and 0x44 instructions issued when obtaining system locks (VM64927 for z/VM 6.1 only)
- Improve workload dispatch algorithm to eliminate erratic virtual machine pause in busy systems with more than 14:1 total virtual to logical CPU over-commitment (VM64887)

---

## Advances in Processor Performance

- The CPU Measurement Facility is a System z hardware facility that characterizes the performance of the CPU and nest:
  - Instructions, cycles, cache misses, and other processor related information
  - Available on z10 EC/BC, z196, z114, and zEC12
- IBM will be using data from this facility to influence future processor design and benchmark validation of those designs
- Will also increase accuracy of future processor capacity sizing tools
- To assist by providing Monwrite sample data containing the counters, please contact Richard Lewis ([rflewis@us.ibm.com](mailto:rflewis@us.ibm.com))

---

## TCP/IP Enhancements

- Stack
  - RFC 4191: Router selection preferences
  - RFC 5175: IPv6 router advertisement flags extension
- FTP
  - IPv6
  - Passwords suppressed in server traces
  - Wildcards supported for BFS files
- SMTP
  - IPv6
  - Includes IPv6 support in CMS NOTE and SENDFILE



## TCP/IP Enhancements

### OSA Diagnostics

- The NETSTAT command has been updated to provide details taken from the OSA Address Table (OAT) via new OSAINFO option
- OSA/SF no longer required to obtain device details
- OSA-Express3 and later

```

VM TCP/IP Netstat Level 620          TCP/IP Server Name: TCPIP

Device K4L3VSW6640DEV: data as of 09/23/11 01:05:21
  OSA Generation:                    OSA-Express3
  OSA Firmware Level:                00000766
  Port Speed/Mode:                   1000 Mbs / Full Duplex
  Port Media Type:                   Multi Mode (SR/SX)
  PCHID:                              0291
  CHPID:                              0053
  Manufacturer MAC Address:          00-14-5E-78-17-F2
  Configured MAC Address:            00-00-00-00-00-00
  Data Device Sub-Channel Address:    6640
  CULA:                               00
  Unit Address:                      40
  Physical Port Number:               0
  Number Of Output Queues:            1
  Number Of Input Queues:             1
  Number Of Active Input Queues:      0
  QDIO CHPID Type:                   OSD
  QDIO Connection:                   Not Isolated
  IPv4 L3 VMAC:                       00-00-00-00-00-00
  IPv4 VMAC Router Mode:              No
  IPv4 L3 VMAC Active:                No
  IPv4 L3 VMAC Source:                n/a
  IPv4 L3 Global VLAN ID Active:      No
  IPv4 Global VLAN ID:                0
  IPv4 Assists Enabled:               00001C71
  IPv4 Outbound Checksum:             00000000
  IPv4 Inbound Checksum:              00000000

  IPv4 Address:                       IPA Flags:
  -----
  9.60.29.53                          00000002

  IPv4 Multicast Address:              MAC Address:
  -----
  224.0.0.1                            01-00-5E-00-00-01

```

---

## Access controls for dedicated or attached devices

- The CP ATTACH and GIVE commands, as well as the DEDICATE statements in the directory will now engage ESM access controls
- Integrated ASCII console on the HMC is also managed
- Full discretionary and mandatory access controls
- RACF support included

---

## Mandatory access controls for virtual consoles

- SET SECUSER and SET OBSERVER are now available when mandatory access controls (security labels) are active
- Virtual security zones (“color coding” of users and resources) can now co-exist with system automation functions
- Also applies to the user ID specified on CONSOLE directory statement
- Users in different zones cannot see or manage each others' virtual console
  - Console cannot be given
  - Console cannot be taken
  - System administrators and automation solutions can use label SYSNONE to allow them access to all consoles

---

## RACF Security Server

- Single System Image Support
  - Automatic propagation of most RACF commands
  - Also works with multiple RACF servers on same z/VM system
- Protected Users
  - User without a password or password phrase will not be revoked due to too many invalid password attempts or inactivity
- High Level Assembler no longer required for most common customizations
- Real device protection
  - ATTACH, GIVE, DEDICATE
  - New VMDEV class
  - Profiles: *RDEV.device.system\_id*
- Support for Diagnose 0xA0 Subcode 0x48
  - Obtain information about any ESM in architecturally defined format

---

## z/OS R12 Equivalency Upgrades

- LDAP
  - Change logging of general resources
  - Password expiration management
- Language Environment (LE) runtime libraries
- Program Management Binder
  - COMPAT supports ZOSV1R10, ZOSV1R11, ZOSV1R12
  - New sub-options on RMODE
  - Compiler parameters can be read from IEWPARMS DDNAME
  - New C/C++ API
- Support for **IBM XL C/C++ Compiler for z/VM, V1.3** (5654-A22)
  - Details can be found in US announcement letter 211-369
- MPROUTE

## z/CMS

- Previously shipped with z/VM as a sample program, now supported as an optional CMS
  - IPL ZCMS
- Enables CMS programs to use z/Architecture instructions and 64-bit registers
- Existing ESA/390 architecture programs continue to run unchanged
  - CMS does not exploit memory above 2 GB
  - CMS provides basic memory management API for memory above 2G
- Programs that examine or change architecture-sensitive memory locations (NUCON) must be updated in order to use z/CMS
- No architectural support for XC mode
  - VM Data Spaces not available

---

## Installation Improvements

- Significant changes to system layout to support Single System Image
- Choose a non-SSI system or a complete 1- to 4-member SSI cluster
  - First or second level
- All installation information is gathered at one time
- All DASD volumes can be labeled at installation time, including the system residence volume
- Turnkey support for zEnterprise ensembles enables clients new to z/VM to easily get started with Unified Resource Manager (zManager)
  - If you have purchased a directory and/or security manager, decline this option during installation; manual enablement is required!

---

## XEDIT – Default changed to mixed case

- For those coming to z/VM from an open system background, the folding of mixed case to upper case is surprising
  
- Many comments along the lines of “it hurts when you do that”
  - Linux can read CMS files
  - Often case-sensitive
  
- Default for other file types changed to CASE MIXED RESPECT
  - No folding
  - To get old behavior, update PROFILE XEDIT to  
SET CASE UPPER RESPECT
  - Or you may wish to consider  
SET CASE MIXED IGNORE



---

## Removed Functions

- Kerberos authentication system
  - IBM Software Announcement 208-249
  
- CMS-based Domain Name Server (NAMESRV)
  - IBM Software Announcement 209-207
  
- RESOURCE option of VMSES/E VMFINS command
  - IBM Software Announcement 210-234
  
- z/VM Manageability Access Point (zMAP) agent and Platform agent for IBM Systems Director for Linux on System z
  - Both previously shipped with z/VM V6.1

---

## *z/VM 6.2 and GDPS Support*

- ***All supported GDPS releases (3.7, 3.8, & 3.9) supported with non-SSI environment***

- See GDPS PSP buckets for required service (z/OS, Linux, & z/VM)
- If GDPS environment shared with older z/VM releases, z/VM service is required on them before adding z/VM 6.2

- ***GDPS support in an SSI environment***

- Design issue when z/OS controlling LPAR resets z/VM SSI member
- **z/VM SSI Toleration Support**
  - CP – VM65176
  - GDPS – PM64211
  - SA MP – IV25032
- **Available for GDPS 3.9 only**

# Statements of Direction

---

# Statements of Direction

Subject to change or withdrawal without notice,  
representing IBM goals and objectives only

Note for withdrawals: Unless otherwise stated, it is IBM's  
intent that z/VM V6.2 will be the last release of z/VM to  
support the indicated function

---

## HiperSockets Completion Queues

### z/VM Statement of Direction: New function

Available April 13, 2012

- Transfer HiperSockets messages asynchronously
- Used whenever traditional synchronous queues are full
- Automatic enablement; no z/VM configuration required
- Helpful when traffic is “bursty”
- Exploitation by CP VSWITCH only; no guest simulation

---

z/VM Performance Toolkit: RMFPMS agent  
z/VM Statement of Direction: Stabilize existing function

- Performance Toolkit processing of the output from Linux rmfpms agent, part of the z/OS RMF PM offering, will no longer be updated
- Performance Toolkit may give incorrect results as the underlying rmfpms agent evolves
- Support for the Linux rmfpms agent has already been withdrawn, but continues to be available on an as-is basis

---

## HMC non-ensemble z/VM System Management

### z/VM Statement of Direction: Withdrawal of existing function

- z/VM V6.2 is the last release of z/VM that will be supported by the non-ensemble z/VM System Management functions of the System z10, z196 and z114
- z/VM virtual server management will continue to be supported using the zEnterprise Unified Resource Manager on the z196 and later

---

## TCP/IP Devices and Daemons

### z/VM Statement of Direction: Withdrawal

- A220 HYPERchannel devices
- CLAW devices
- DHCP daemon
- LPSERVE (LPD)
  - RSCS LPD will continue to be provided at no charge
  - Does not affect LPR (client)



---

## User Class Restructure and OVERRIDE utility

### z/VM Statement of Direction: Withdrawal

- User Class Restructure (UCR) was first introduced in VM/SP Release 6 to allow changes to the privilege classes associated with CP commands and DIAGNOSE sub-codes
  
- OVERRIDE utility was a “compiler” used to create special UCR-type files in the spool
  
- Function replaced by MODIFY COMMAND capability in VM/ESA
  - Use the CP MODIFY COMMAND command or SYSTEM CONFIG statement

---

## Cross System Extensions (CSE)

### z/VM Statement of Direction: Withdrawal

- The z/VM Single System Image (VMSSI) feature replaces the functions provided by CSE:
  - Logon once in the cluster, with exceptions
  - Cross-system MESSAGE and QUERY commands
  - Cross-system LINK (XLINK)
  - Shared spool
  - Shared source directory
  
- VMSSI brings additional value such as autonomic minidisk cache management and a single point of maintenance

---

## Support for GDPS/PPRC

### z/VM Statement of Direction: New function

- Disk subsystem preemptive HyperSwap
  - Storage controllers will notify host when failure is predicted
  - HyperSwap before I/O errors are generated
  
- HyperSwap scalability
  - Summary “PPRC Suspend” event notification by storage controller
  - Avoid separate notification for each disk
  
- Future z/VM release support for an alternate subchannel set in which to place PPRC secondary devices

**Function Shipped  
Prior to z/VM 6.2.0**

---

## Previously shipped Functional Enhancements Included in z/VM V6.2

- XRC timestamps
- Hyperswap improvements
- SSL Server Reliability and Scalability
- CPU Measurement Counter Facility Host support
- zEnterprise Unified Resource Manager

APAR numbers shown apply to z/VM 6.1 and z/VM 5.4 unless otherwise stated

## XRC Timestamps

VM64814 and VM64816

- CP will sync with STP at IPL and, optionally, obtain time zone and leap seconds from STP
  - No need to deactivate/activate LPAR
  
- Correct time will be placed in all host and guest I/O
  - CP will monitor STP time signals
  
- Enabled via SYSTEM CONFIG with option to skip timestamp or delay I/O if CP is unable to sync with STP
  
- No virtualization of STP
  - Option for 2<sup>nd</sup> level systems to stamp I/O without use of STP

---

## Hyperswap Improvements

VM64815 and VM64816

- CP HYPERSWAP command now has additional controls for missing interrupt handling
  - Do not trigger automatic quiesce (default)
    - GDPS will not be notified
  - Trigger automatic quiesce after specified number of MI detection intervals
    - GDPS will be notified
  
- Better management of PAV and HyperPAV devices
  
- Avoid unnecessary hyperswaps due to normal maintenance activities
  - Concurrent storage controller upgrade
  
- New wait state 9060 if abend occurs when Hyperswap is in progress
  - no checkpoint taken, no automatic dump
  - restart dump if dedicated dump volume, else standalone dump

---

## SSL Server Reliability and Scalability

PK97437, PK97438, PK75662

- Major rewrite of SSL server
  - Updates to TCP/IP stack, as well
  - Scalable
- Multiple SSL servers with session cache manager and shared database
  - Balance total number of sessions against number of sessions per server
- Significant performance improvements
  - Interactive workloads such as telnet
  - Session establishment costs, particularly during mass reconnect
- Migration required if using pre-PTF version
  - <http://www.vm.ibm.com/related/tcpip/tcsslspe.html>
  - Not trivial; read carefully



## CPU Measurement Facility Counters – Host Support

VM64961

- Sets of counters for each logical processor that count events such as cycle, instruction, and cache directory-write counts
  - Same COUNTER information as z/OS partitions
- Accumulation is a relatively low-overhead activity and is performed automatically by the machine when the counters are authorized, enabled, and activated
- Authorization controlled by a logical partition's Security settings in its activation profile
- Enablement, activation, and data collection controlled by z/VM MONITOR command

---

## zEnterprise Unified Resource Manager

VM64822, VM64904, VM64917, VM64956, VM64957

- z/VM V6 only
  - Turn-key installation option to enable virtual server management via zEnterprise Unified Resource Manager (z/VM V6.2 only)
    - Only for “kicking the tires”
- Enables Unified Resource Manager to perform system and virtual server management tasks
  - Virtual server configuration
  - Disk storage management
  - Virtual network management
  - Performance monitoring
- CP, CMS, LE, TCP/IP, DIRMAINT, Performance Toolkit, HCD
- <http://www.vm.ibm.com/service/vmrequrm.html>

---

## zEnterprise Unified Resource Manager Ensemble Membership

- If configured to participate in an ensemble, z/VM will automatically join the ensemble at IPL
- Configuration tasks
  - Set up OSM and OSX channel paths
  - Set up controllers for IEDN and INMN networks
    - Pre-defined controllers DTCENS1 and DTCENS2 for exclusive use by ensemble networks
    - DTCENS1 automatically creates a VSWITCH to provide SMAPI connectivity to INMN network
  - Configure directory manager (REQUIRED)
  - Configure SMAPI servers
- See chapter "Configuring z/VM for an Ensemble" in CP Planning and Administration manual

*Thanks!*



*Contact Information:*

Romney White  
romneyw@us.ibm.com  
+1-607-429-4054



[www.vm.ibm.com](http://www.vm.ibm.com)