



IBM GSE Berlin 2007

# GSE Berlin Session V11 z/VM Platform Update: Introducing z/VM Version 5 Release 3

Reed A. Mullen / Erich Amrehn  
[mullenra@us.ibm.com](mailto:mullenra@us.ibm.com) / [amrehn@de.ibm.com](mailto:amrehn@de.ibm.com)  
Virtualization Strategy Manager for System z

# Trademarks

The following are trademarks of the International Business Machines Corporation in the United States and/or other countries. For a complete list of IBM Trademarks, see [www.ibm.com/legal/copytrade.shtml](http://www.ibm.com/legal/copytrade.shtml): AS/400, DB2, e-business logo, ESCON, eServer, FICON, IBM, IBM Logo, iSeries, MVS, OS/390, pSeries, RS/6000, S/390, System Storage, System z9, VM/ESA, VSE/ESA, WebSphere, xSeries, z/OS, zSeries, z/VM.

The following are trademarks or registered trademarks of other companies

Java and all Java-related trademarks and logos are trademarks of Sun Microsystems, Inc., in the United States and other countries.

LINUX is a registered trademark of Linux Torvalds in the United States and other countries.

UNIX is a registered trademark of The Open Group in the United States and other countries.

Microsoft, Windows and Windows NT are registered trademarks of Microsoft Corporation.

SET and Secure Electronic Transaction are trademarks owned by SET Secure Electronic Transaction LLC.

Intel is a registered trademark of Intel Corporation.

\* All other products may be trademarks or registered trademarks of their respective companies.

## NOTES:

Performance is in Internal Throughput Rate (ITR) ratio based on measurements and projections using standard IBM benchmarks in a controlled environment. The actual throughput that any user will experience will vary depending upon considerations such as the amount of multiprogramming in the user's job stream, the I/O configuration, the storage configuration, and the workload processed. Therefore, no assurance can be given that an individual user will achieve throughput improvements equivalent to the performance ratios stated here.

IBM hardware products are manufactured from new parts, or new and serviceable used parts. Regardless, our warranty terms apply.

All customer examples cited or described in this presentation are presented as illustrations of the manner in which some customers have used IBM products and the results they may have achieved. Actual environmental costs and performance characteristics will vary depending on individual customer configurations and conditions.

This publication was produced in the United States. IBM may not offer the products, services or features discussed in this document in other countries, and the information may be subject to change without notice. Consult your local IBM business contact for information on the product or services available in your area.

All statements regarding IBM's future direction and intent are subject to change or withdrawal without notice, and represent goals and objectives only.

Information about non-IBM products is obtained from the manufacturers of those products or their published announcements. IBM has not tested those products and cannot confirm the performance, compatibility, or any other claims related to non-IBM products. Questions on the capabilities of non-IBM products should be addressed to the suppliers of those products.

Prices subject to change without notice. Contact your IBM representative or Business Partner for the most current pricing in your geography.

References in this document to IBM products or services do not imply that IBM intends to make them available in every country.

Any proposed use of claims in this presentation outside of the United States must be reviewed by local IBM country counsel prior to such use.

The information could include technical inaccuracies or typographical errors. Changes are periodically made to the information herein; these changes will be incorporated in new editions of the publication. IBM may make improvements and/or changes in the product(s) and/or the program(s) described in this publication at any time without notice.

Any references in this information to non-IBM Web sites are provided for convenience only and do not in any manner serve as an endorsement of those Web sites. The materials at those Web sites are not part of the materials for this IBM product and use of those Web sites is at your own risk.

# Topics

- **Recent z/VM Release History**
- **z/VM Version 5 Release 3 Functional Highlights**

# Recent z/VM Release History

## z/VM Version 5: High-Value Virtualization Technology

- ★ Generating new business with Linux on System z
- ★ Enabling growth for existing VM customers

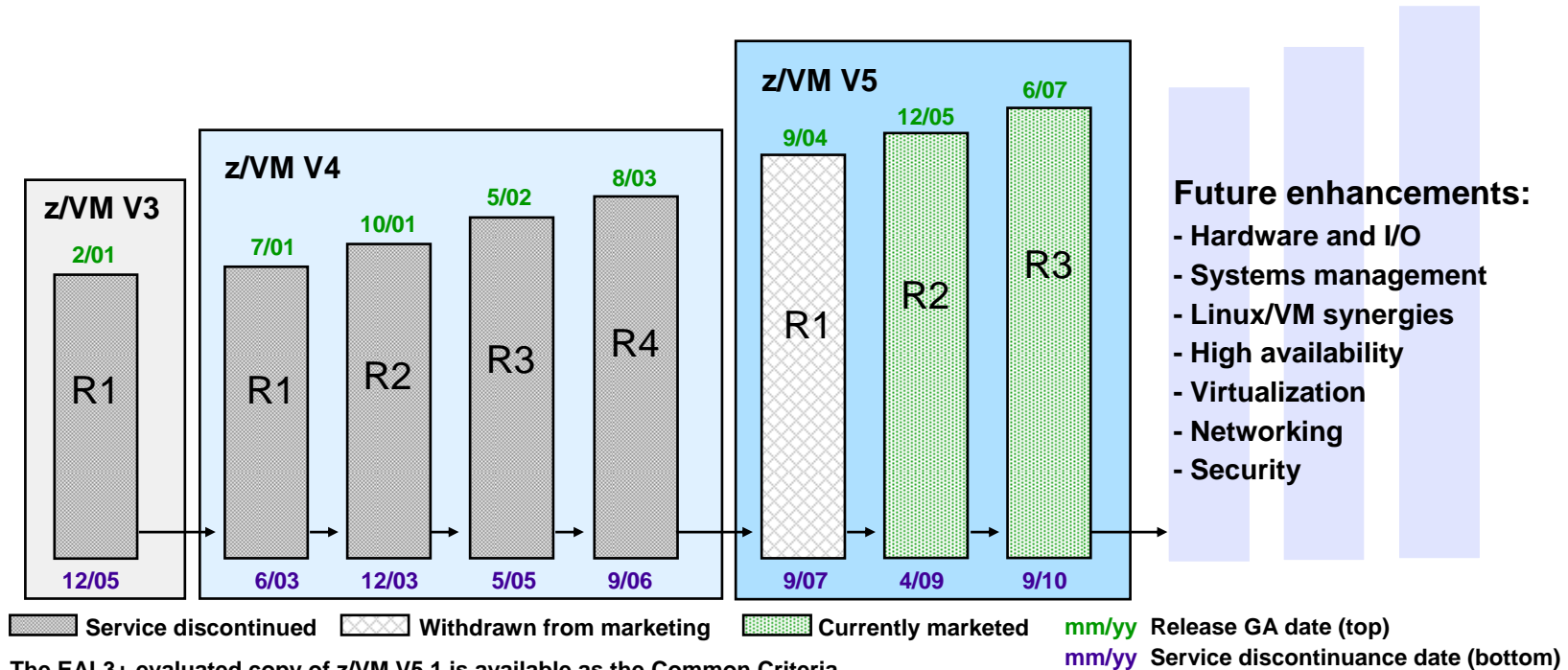

The EAL3+ evaluated copy of z/VM V5.1 is available as the Common Criteria Certification feature of z/VM V5.2

**z/VM V5.2 will be withdrawn from marketing on June 15, 2007**

Note: All statements regarding IBM's plans, directions, and intent are subject to change or withdrawal without notice, and represent goals and objectives only.

# N\_Port ID Virtualization (NPIV)

Without N\_Port ID Virtualization

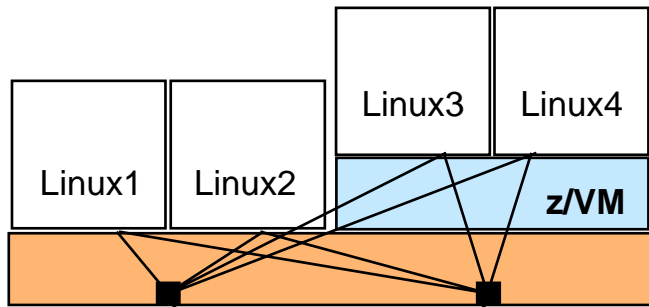

With N\_Port ID Virtualization

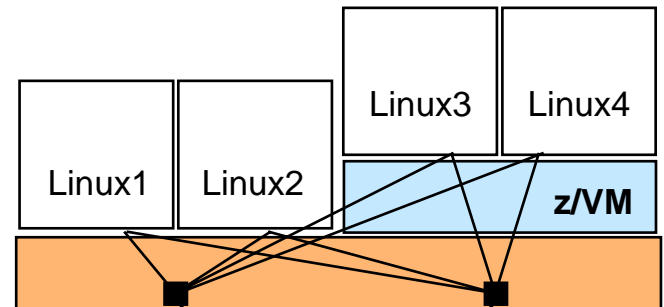

*No NPIV:*  
Hosted Linux images can access all the LUNs that are accessible to the real hardware channels.

*With NPIV:*  
Each Linux image is separately authorized via zoning and LUN-masking with a unique WWPN for each subchannel or virtual host-bus adapter.

**Problem!**

Linux1	Linux1	Linux1	Linux1
Linux2	Linux2	Linux2	Linux2
Linux3	Linux3	Linux3	Linux3
Linux4	Linux4	Linux4	Linux4

Linux1	Linux2	Linux3	Linux4
Linux2			
Linux3			
Linux4			

## z/VM Support for NPIV

- **FICON Express features on System z9 support FCP N\_Port ID Virtualization**
- **NPIV enables zoning and LUN masking on a virtual machine basis**
- **Multiple operating system images can now concurrently access the same or different SAN-attached devices (LUNs) via a single, shared FCP channel**
  - Can increase channel utilization
  - Less hardware required
  - Helps reduce the complexity of physical I/O connectivity
- **Supported by z/VM V5.3 and V5.2; z/VM V5.1 support is available with the PTF for APAR VM63744**
  - Note: z/VM V5.1 cannot be installed from DVD to SCSI disks when NPIV is enabled

## z/VM V5.2 Post-GA Support (continued)

- **System and guest exploitation of real HiperSockets IPv6 support\***
  - Includes support for simulated HiperSockets devices (HiperSockets Guest LANs)
  - z/VM TCP/IP support for IPv6 transmissions over real and simulated HiperSockets
- **OSA GARP VLAN Registration Protocol (GVRP) support\***
  - Allows registration of VLAN IDs; OSA-Express can become a participant or end station in a GVRP network
  - Provides VLAN filtering for z/VM Layer 2 and Layer 3 switches (can reduce unwanted inbound VLAN traffic)
  - Support details: VLAN tagging for z/OS, z/VM and Linux; VLAN priority queuing for z/OS and Linux
  - Also supported by z/VM V5.1 with PTFs for APARs VM63784 and PK08444
- **Parallel Access Volume (PAV) support\***
  - Provides full support for 2105/2107 PAV feature for minidisk I/O
  - z/VM I/O dispatcher will exploit real PAV hardware features for balancing workload across PAV alias volumes
- **Cooperative memory management\*\***
  - Enhances efficiency of managing virtual memory page allocations
  - z/VM Virtual Machine Resource Manager instructs Linux guest images to reduce page consumption
  - Linux support currently available with SLES 9 and 10

\* Requires the PTF for APAR VM63952

\*\* Requires the PTF for APAR VM64085

# IBM 3592 Model E05 Tape Drive Encryption Support

## *Addressing Data Security Needs*

- **Tape encryption support is a standard feature on all IBM System Storage TS1120 Model E05 drives**
- **z/VM supports drive-based data encryption**
  - Requires the IBM Encryption Key Manager to run on an operating system other than z/VM using an out-of-band connection (e.g., TCP/IP) to the tape control unit
  - Includes encryption support for DDR, SPXTAPE, and guest systems that do not provide their own encryption support (e.g., CMS, Linux)
  - Includes support for guests (e.g., z/OS) that can control the tape encryption facilities themselves and optionally run the Encryption Key Manager
- **z/VM V5.1 and V5.2 require PTF for APAR VM64063**
  - This support is included in the z/VM V5.3 base product
- **DFSMS/VM FL221 support available with PTF for APAR VM64062**
  - Locates encryption-capable 3592 tape drives in an Enterprise Automated Tape Library
  - Provides tape encryption capabilities for a z/VSE guest running on z/VM
  - PTF is required for z/VM V5.1, V5.2 and V5.3





# z/VM Version 5 Pricing

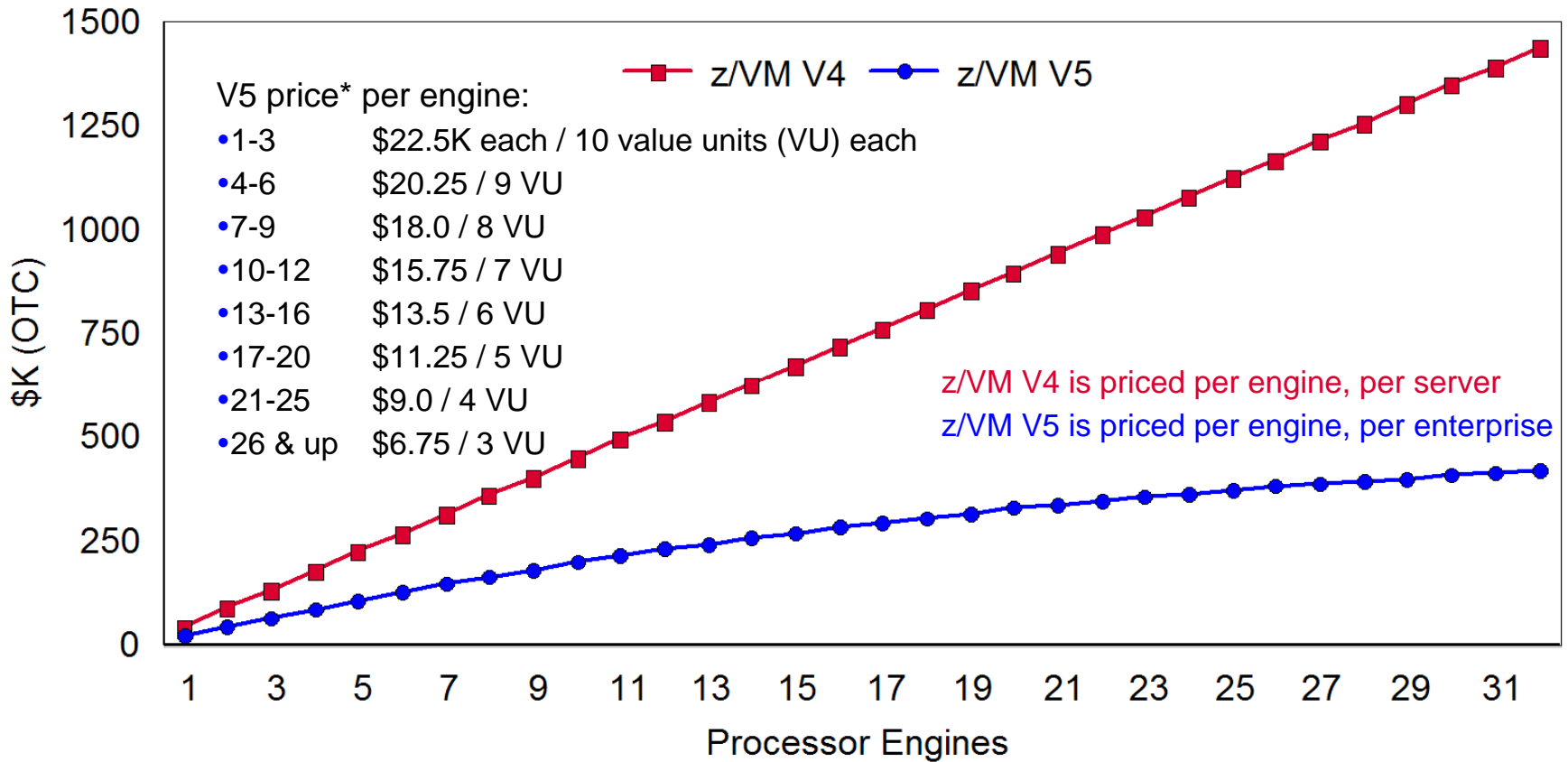

\*U.S. prices as of 1 Feb 2007

# z/VM Version 5 Product Packaging Changes

- **DFSMS/VM is no longer *automatically* shipped with the base product**
  - It is now a no-charge feature and must be ordered via the SDO
- **3270 PC File Transfer product (5664-281) is *included* with base product**
  - Delivered with z/VM V5 as a sample program (with no support)
- **Restricted source feature and PL/X source *no longer ship* with z/VM V5**
  - Both are available as no-charge downloads from IBM Resource Link for z/VM V5 customers
- **Tivoli Storage Manager for VM is *no longer pre-installed* with z/VM V5**
  - Consider TSM for Linux on zSeries for future TSM server support
- **National Language features for ISPF have been *removed* from the SDO**
  - Features can be ordered using the standalone ordering process
- **HCD/HCM *upgraded* to new level**
- **z/VM Collection Kit publications *available on DVD* (supplied with order)**
- ***z/Architecture CMS is shipped as a sample program of z/VM V5.3***
- ***RSCS is now a per-processor, one-time-charge priced feature of z/VM V5.3***

z/VM V5.3 changes are highlighted in *blue*

# Remote Spooling Communications Subsystem (RSCS)

*Optional Priced Feature of z/VM V5.3* 

- **Remote Spooling Communications Subsystem (RSCS) V3.2.0 (5684-096) has been repackaged as a priced, optional preinstalled feature of z/VM V5.3**
  - One-time charge licensing using processor-based Value Units (consistent with z/VM V5 and other priced features)
  - Operates on standard and IFL processors
  - Operates **only** with z/VM V5.3
- **Provides dynamic command authorization support via a new server: RSCSAUTH**
  - Runs in a disconnected virtual machine and is authorized for all RSCS commands
  - Can eliminate the need to re-cycle RSCS when changing system and link authorizations
- **IBM intends to withdraw the standalone RSCS V3.2 product from marketing effective September 30, 2007**

Note: All statements regarding IBM's plans, directions, and intent are subject to change or withdrawal without notice, and represent goals and objectives only.

# Functions Removed from z/VM Version 5

- RTM and PRF features (replaced by Performance Toolkit for VM)
- SPTAPE (use SPXTAPE to backup Spool files)
- V=R and V=F virtual machine support
- CMS support for Java and NetRexx programs
- System Administration Facility
- Support for Server-Requester Programming Interface (SRPI)
- *ROUTED and BOOTP servers have been removed from z/VM V5.3*
- Device support
  - DASD/Controllers: 3370, 3375, 3380(1), Multiprise Internal Disk, 9332, 9335, 9336(2), 9340, 3830, 3880
  - Optical: 3995 Optical Dataserver
  - Tape/Controllers: 2440, 3420, 3422(3), 3424, 3430, 9348, 3803
  - Communications: all SDLC, BSC, and CETA ICAs, 3705, 3720, and 3725 Communication Controllers, 8232 LAN Channel Station
  - Terminals: 2741 and TWX Terminal Model 33/35 (TTY) as virtual consoles
  - Refer to the z/VM V5.2 GIM for a complete listing of devices supported



## Notes:

- (1) RAMAC-emulated 3380 models J and K and 3390 DASD configured for 3380-track-compatibility are supported
- (2) 9336 is a supported device geometry for Virtual Disks in Storage and emulated SCSI LUNs
- (3) OMA/2 CD-ROM emulating a 3422 is supported

z/VM V5.3 changes are highlighted in *blue*

# z/VM Version 5 Product Installation Support

- **z/VM V5.3 can be installed on:**
  - 3390-formatted DASD volumes (Models 3 and 9)
  - FCP-attached SCSI disks: ESS 750, ESS 800, DS8000, DS6000
- **Product media and distribution options:**
  - DVD
  - 3590 and 3480 tape
  - Electronic delivery of SDO-licensed products
- **System Residence (SYSRES) volume changes**
  - Spool and paging space removed from SYSRES
  - Located on separate installation volumes
- **New installation method simplifies the task for new and experienced users**

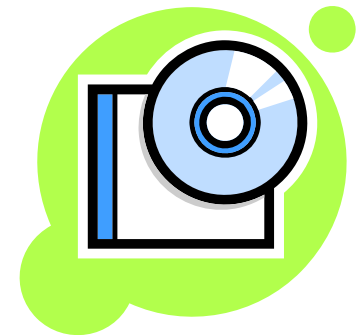

z/VM V5.3 changes are highlighted in **blue**

# Key z/VM V5.3 Business Value Propositions

- **Large, single-image, resource-balanced “Scale out” and “Scale up” support for hosting virtual server workloads**
  - Large real memory exploitation support (greater than 128 GB)
  - Single-image CPU support for 32 processors
  - Enhanced networking bandwidth and availability support with OSA-Express2 Link Aggregation (Statement of Direction)
  - HyperPAV I/O support for IBM System Storage DS8000
  - Concurrent FlashCopy I/O support for one-to-many volumes
  - Enhanced memory management for Linux guests running on System z9 servers
- **Specialty processor support for z/OS guests**
  - Enhanced z/OS-on-z/VM development / test support
- **LDAP support for guest authentication**
  - Enhanced virtual server security infrastructure support
- **Staff productivity gains with IBM Director for Linux on System z**

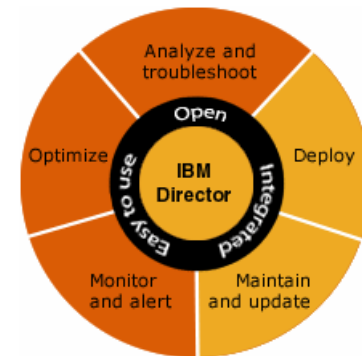
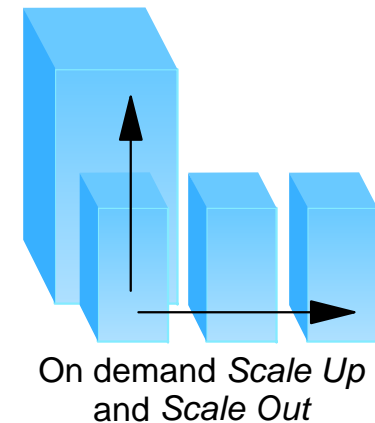

# z/VM Version 5 Release 3 New Function Highlights

## *Announced February 6, 2007; Planned Availability June 29, 2007*

- **Processor and I/O support**
  - Single-image support for up to 32 CPUs
  - Guest support for specialty processors
  - Enhanced SCSI support
  - HyperPAV support for IBM DS8000
  - FlashCopy I/O support enhancements
- **Virtualization support**
  - Additional z/VM support for large real memory configurations (>128 GB)
  - Collaborative Memory Management Assist
  - OSA-Express2 link aggregation (SOD)
  - Virtual Switch SNMP agent support
  - Enhanced usability for z/VM Virtual Switch and Guest LAN support
  - Guest program-directed IPL support
  - Guest MIDAW support
  - Guest ASCII console support
- **Networking**
  - Enhanced IP failover
  - z/VM TCP/IP support enhancements
  - Currency support for SSL server
  - Dynamic SSL/TLS support
- **Systems management**
  - z/VM system management API enhancements
  - User Directory COMMAND support
  - Asynchronous CP command API
  - LDAP server and client support
  - Password phrase support
  - RACF support enhancements
  - Installation and service enhancements
  - Performance Toolkit support

Note: All statements regarding IBM's plans, directions, and intent are subject to change or withdrawal without notice, and represent goals and objectives only.



# z/VM Support for Specialty Processors

- **z/VM V5.3 introduces support for zAAP and zIIP specialty processors**
  - System z Application Assist Processors (zAAPs) – provide an economical Java execution environment for z/OS and z/OS.e
  - System z9 Integrated Information Processors (zIIPs) – designed to help improve resource optimization and lower the cost for eligible z/OS and z/OS.e workloads by offloading software system overhead from standard Central Processors (CPs); this includes TCP/IP back-end and certain DB2 processing
- **z/VM support is provided for z/OS guest exploitation**
  - Offers additional hardware support for z/OS-on-z/VM development and test support
- **Two levels of z/VM support:**
  - *Simulation support*
    - z/VM dispatches virtual zAAPs and zIIPs on real CP engines
    - Only possible if the underlying hardware is capable of supporting the real engine type
    - Does not require activation of real specialty engine(s) within the mainframe server
  - *Virtualization support*
    - z/VM dispatches virtual zAAPs and zIIPs on corresponding real specialty engines
- **Consistent with z/OS, there are no z/VM license fees associated with real zAAP or zIIP processors**



# Specialty Processor Support Example

## *Simulating Specialty Engines in Virtual Machines*

- Allows users to discover the operational aspects of using zAAPs and zIIPs in a z/OS environment without having to purchase real specialty processors
- May help users assess specialty-processor eligible workloads in a z/OS environment
- Provides a function test environment for z/OS workloads that use specialty processors
- Consumes CP processor capacity to host virtual zAAP and zIIP processor cycles

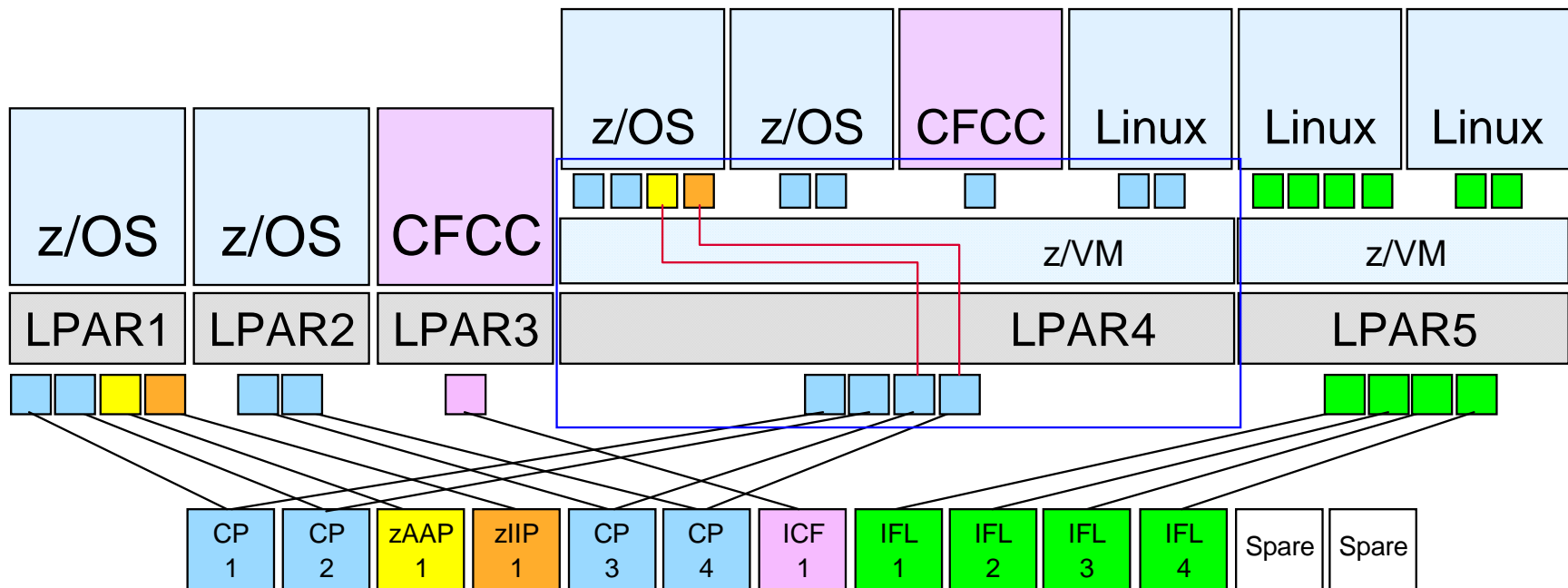

# Specialty Processor Support Example

## Using Real Specialty Engines in Virtual Machines

- Allows users to test and verify z/OS specialty processor support on the real hardware
- Users can maximize real specialty processor utilization by sharing processors among production and test LPARs
- Consumes specialty processor capacity to host virtual zAAP and zIIP processor cycles

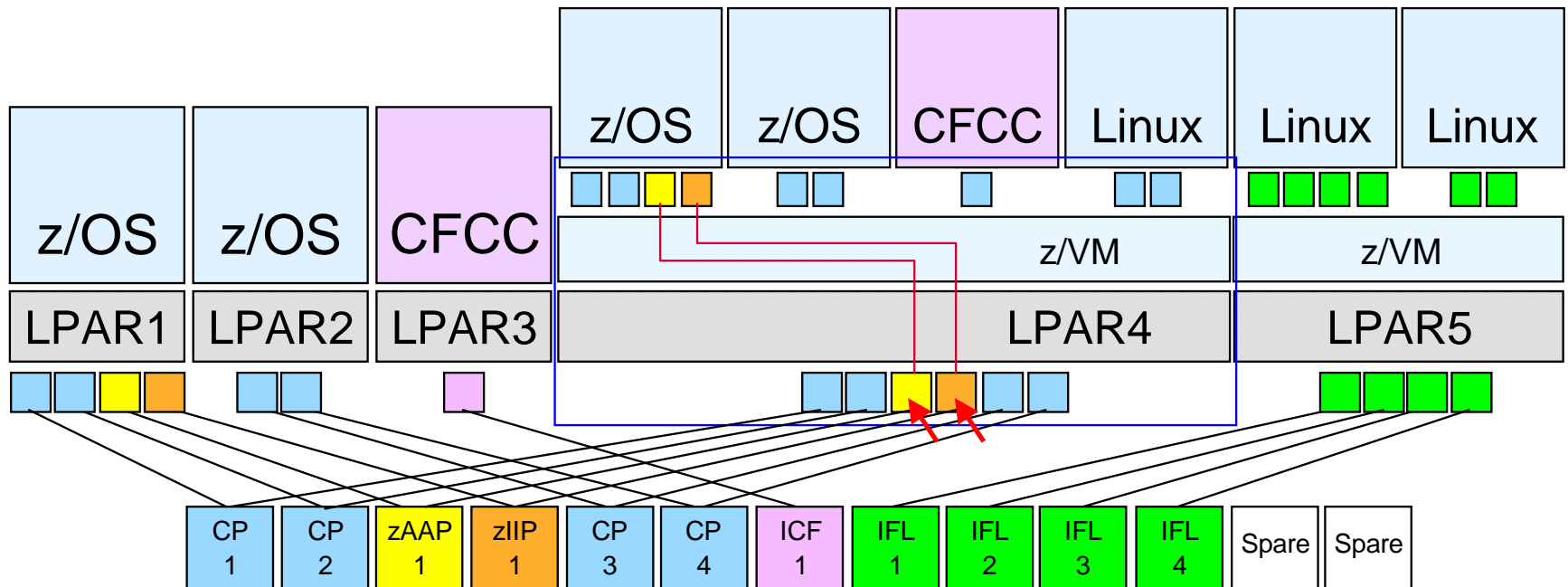

# z/VM Version 5 Support for FCP-Attached SCSI Disks

## *Integrate Your z/VM Systems with Storage Area Networks*

- **z/VM V5.3, V5.2 and V5.1 allow FCP-attached SCSI disks to be used for both system use (CP/CMS) and guest images (e.g., Linux, z/VSE)**
- **SCSI disks are emulated as 9336 Model 20 FBA devices for system use**
  - Enables support for install, paging, spooling, directory services, minidisks
  - Guest systems supporting FBA can also use emulated SCSI disks
  - Emulation support currently limits usable disk space to nearly 1 TB for CP volumes and 381 GB for CMS and GCS
  - Paging, spooling, and directory space must reside in first 64 GB
- **Non-emulated SCSI disks can still be attached to virtual machines**
  - For boot and/or data operations
  - Requires SCSI support in guest operating system
- **Currently supported SCSI disks:**
  - IBM TotalStorage Enterprise Storage Server Models 750 and 800
  - IBM System Storage DS8000 and DS6000
  - Generic SCSI driver available for other disks
- **SCSI-only disk configurations are now possible with z/VM V5**



## z/VM V5.3 Enhanced SCSI Support

- **Support for Point-to-Point Fibre channel links**
  - May provide a lower-cost installation than the current requirement for a Fibre channel switched fabric
- **z/VM will dynamically determine preferred paths for emulated FBA devices on SCSI disks in an IBM System Storage DS6000**
  - Users no longer need to specify which paths are preferred in a SET EDEVICE command or an EDEVICE configuration-file statement
- **Faster formatting of emulated FBA devices on SCSI disks in an IBM Enterprise Storage Server (ESS) or IBM System Storage DS8000**
- **Additional SCSI device characteristics are displayed when using the QUERY EDEVICE DETAILS command**
- **z/VM will check for erroneous mapping of multiple emulated-device definitions onto the same SCSI disk when bringing emulated disks online**

# Understanding z/VM Support for SCSI Disks

- **z/VM ECKD I/O can achieve a higher level of performance than SCSI disk I/O**
  - Continue to use ECKD disks for CP/CMS I/O if it is an option
- **Increased path length of z/VM SCSI disk I/O can be offset**
  - Reduce over commitment of virtual-to-real memory (i.e., reduce paging)
  - Use minidisk cache for read-mostly I/O
  - Additional processor cycles will offset increased SCSI I/O path length
- **Sharing FBA-emulated SCSI disks among Linux images can offer disk and administrative savings**
  - Allows partitioning of SCSI disks using z/VM minidisk support (includes exploitation of minidisk cache support)
  - Allows use of tuning options like “Set Throttle” and “Set IOPriority”
  - Performance monitoring of emulated disks is functionally richer than SCSI disks accessed via dedicated FCP-subchannels
- **IBM System Storage DS6000 offers a low-cost ECKD option for z/VM data**

## z/VM HyperPAV Support

- **IBM System Storage DS8000 HyperPAV is designed to:**
  - Provide more efficient Parallel Access Volumes (PAV) function
  - Help customers who implement larger volumes to scale I/O rates without the need for additional PAV-alias definitions
  - Help reduce overhead, improve addressing efficiencies, and provide storage capacity and performance improvements
  - Enable a dynamic response to changing workloads
  - Reduce costs via simplified management of aliases
  - Enable customers to stave off migration to larger volume sizes
- **z/VM support is designed to:**
  - Potentially reduce the number of alias-device addresses needed for parallel I/O operations
  - Provide support of HyperPAV volumes as linkable minidisks for guest operating systems, such as z/OS, that exploit this new PAV architecture
  - Provide the potential benefits of HyperPAV volumes for minidisks owned or shared by guests that do not specifically exploit HyperPAV volumes (e.g., CMS, Linux)

# z/VM FlashCopy I/O Support Enhancements

- **Support enhancements intended to simplify the tasks required to automate backups and make multiple copies of disk data**
- **z/VM support for the FlashCopy V2 feature of IBM System Storage disk devices has been enhanced to include the capabilities to:**
  - Allow multiple targets (up to 12) of one source to be copied with a single operation
  - Determine the status of FlashCopy requests by allowing users to query the number of FlashCopy relationships active for one or more of their virtual disks
  - Exploit hardware support for asynchronous cache destage and discard
    - Designed to eliminate delayed hardware response messages
    - Makes a FlashCopy operation appear synchronous to the issuing virtual machine
    - May help facilitate automation of processes that exploit this technology

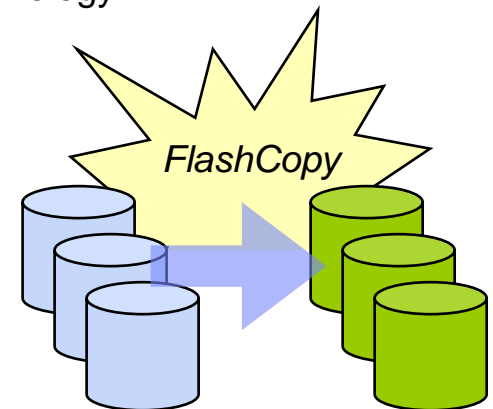

# Enhanced z/VM Support for Large Real Memory

## Even Greater “Scale Up” and “Scale Out” Support

- **z/VM V5.3 expands the amount of real memory that can be exploited to host virtual server environments**
  - With z/VM V5.2, page management control blocks (PGMBKs) must reside in the first 2 GB of addressable memory
    - Can result in a real-memory constraint when there is a very large amount of active virtual memory (e.g., 224 to 256 GB)
  - z/VM V5.3 allows PGMBKs to be located above the 2 GB address line
  - Enhanced management of contiguous page frames may also reduce storage management overhead and help improve system performance
- **z/VM V5.3 can exploit more than 128 GB of real memory**
  - Allows z/VM to host virtual server workloads that generate more active virtual memory than what can be supported by z/VM V5.2
  - Users may be able to consolidate more memory-intensive virtual server images on a single copy of z/VM
  - Benefits most customers who experience storage constraints, regardless of the amount of central storage configured for z/VM use
  - Allows users to exploit z/VM data-in-memory techniques (e.g., virtual networking, virtual disks in storage, shared program executables) on an even greater scale

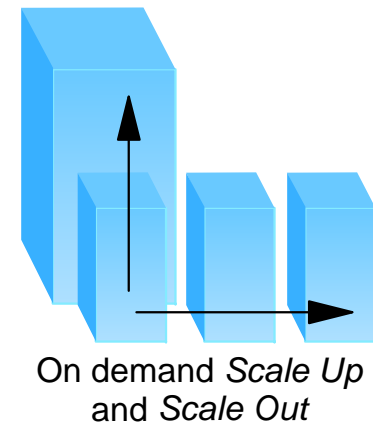



# Linux and z/VM Technology Exploitation

## Collaborative Memory Management Assist (CMMA)

- Extends coordination of memory and paging between Linux and z/VM to the level of individual pages
- z/VM reclaims “unused” pages at higher priority
- Bypass host page writes for unused and “volatile” pages (clean disk cache pages)
- Signal exception if guest references discarded volatile page
- Use Host Page-Management Assist to re-instantiate pages for next use
- Supported by System z9
- z/VM support included in V5.3
- IBM is working with its Linux distribution partners for exploitation support

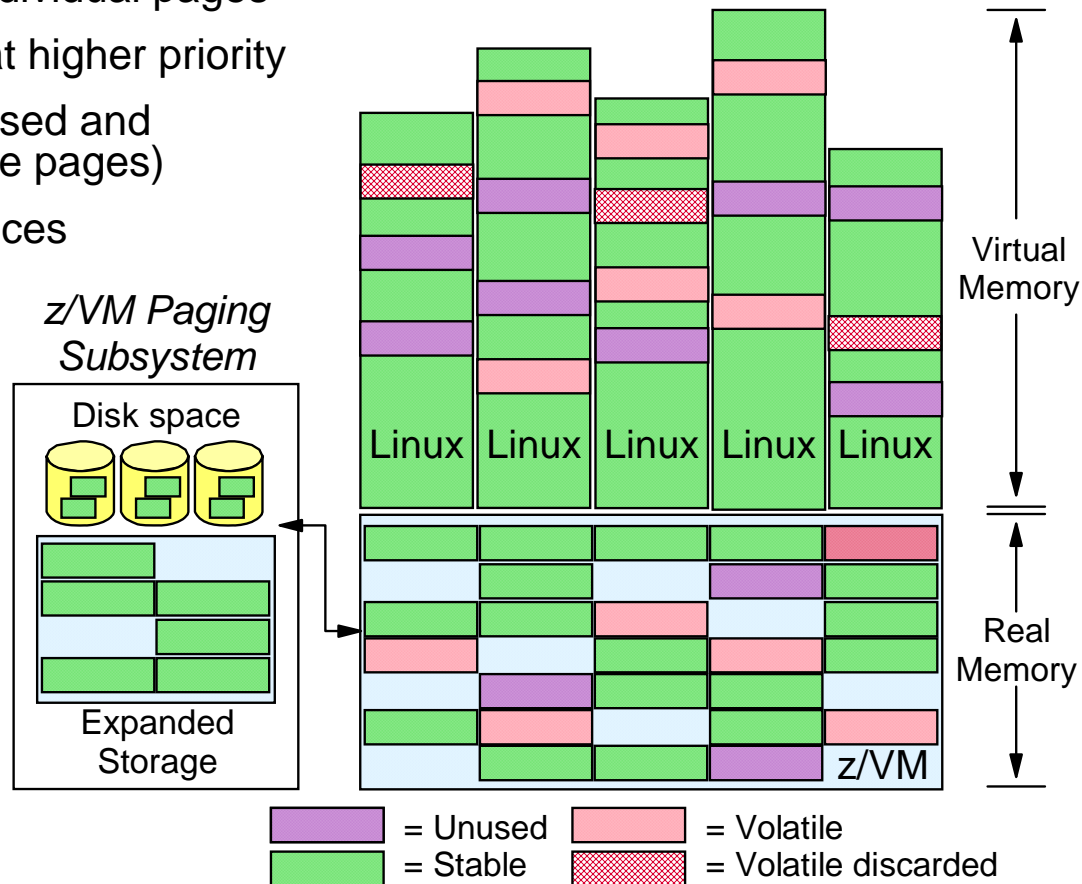

# OSA-Express2 Link Aggregation Support

- **z/VM support for IEEE 802.3ad Link Aggregation**
- **Requires associated OSA-Express2 support planned to be available on IBM System z9 servers**
- **Groups available OSA-Express2 adapters for use by the z/VM Virtual Switch**
  - Up to 8 adapters can be aggregated per virtual switch
  - Increases Virtual Switch bandwidth and provides near seamless failover in the event of a failed controller, link or switch
  - Only supported for Layer 2 switches
- **Enables increased scalability for virtual network I/O**
- **Includes support to recover from a failed external switch**
- **Enhances support for business continuance**

Note: All statements regarding IBM's plans, directions, and intent are subject to change or withdrawal without notice, and represent goals and objectives only.

# z/VM VSWITCH Link Aggregation Support

## Enhanced Networking Bandwidth and Business Continuance

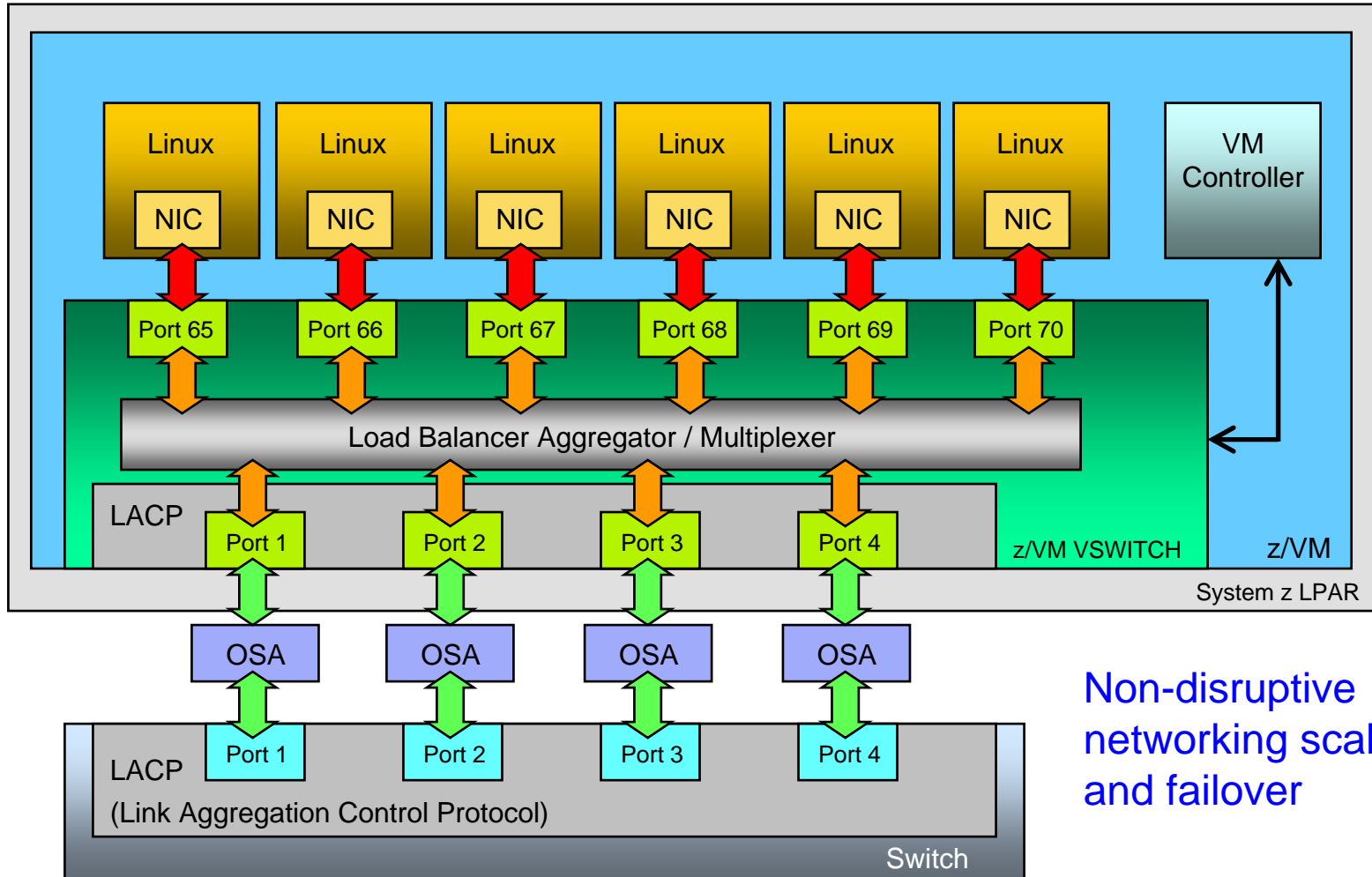

Non-disruptive networking scalability and failover

# Recovery of a Failed Switch

## Additional Business Continuance Support

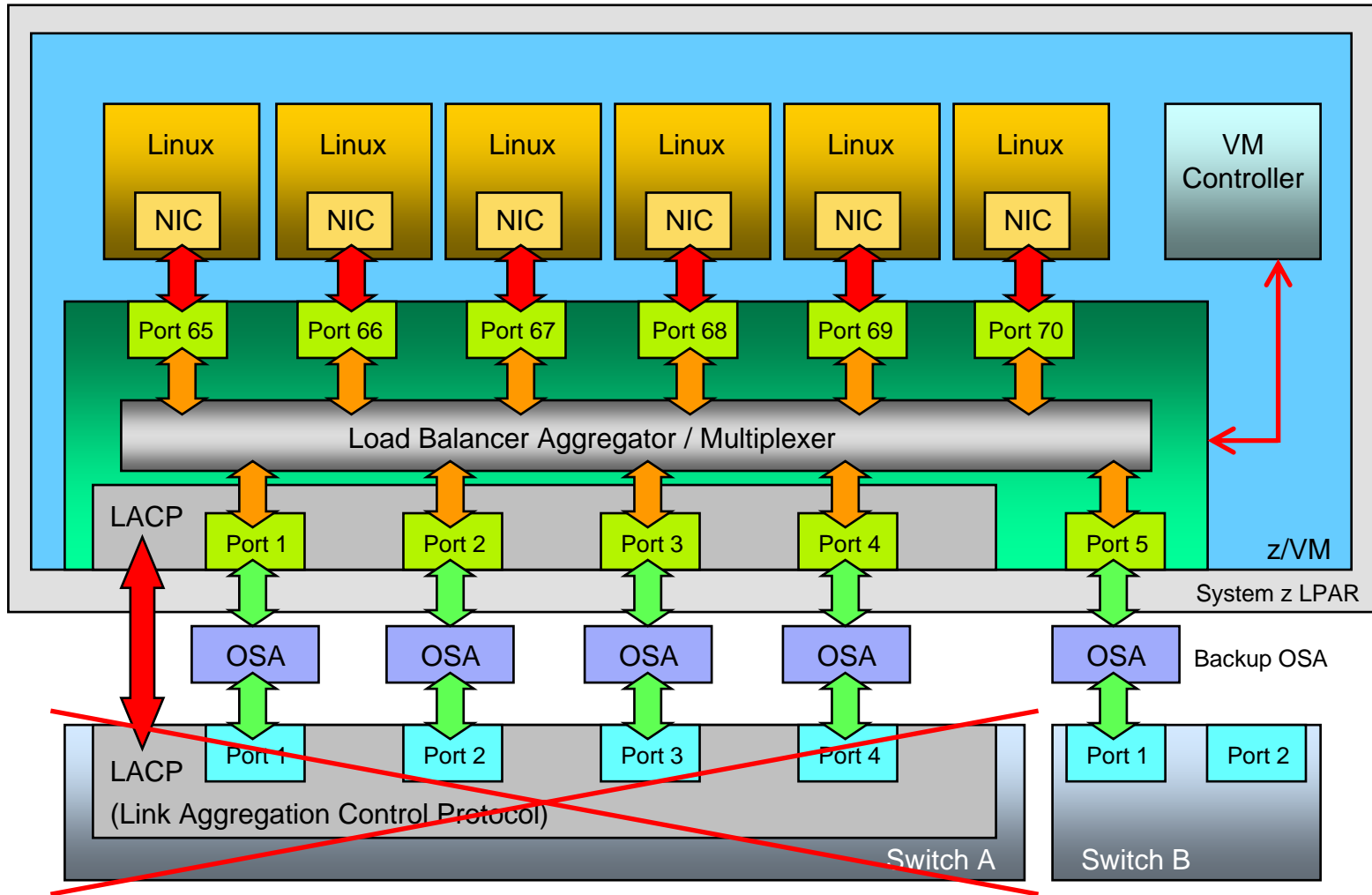

# z/VM Virtual Switch SNMP Support

- **Helps enhance virtual network management with additional support for Simple Network Management Protocol (SNMP)**
- **Provides an SNMP subagent that will return Bridge MIB (Management Information Base) data for the z/VM Virtual Switch**
  - MIB data returned is defined by RFC 1493
  - The subagent acquires the information using a Control Program Diagnose interface (Diagnose x'26C')
- **Helps network administrators:**
  - Manage virtual network performance
  - Find and solve virtual network problems
  - Plan virtual network growth
- **Support also provides a programming interface to obtain information about virtual networks**

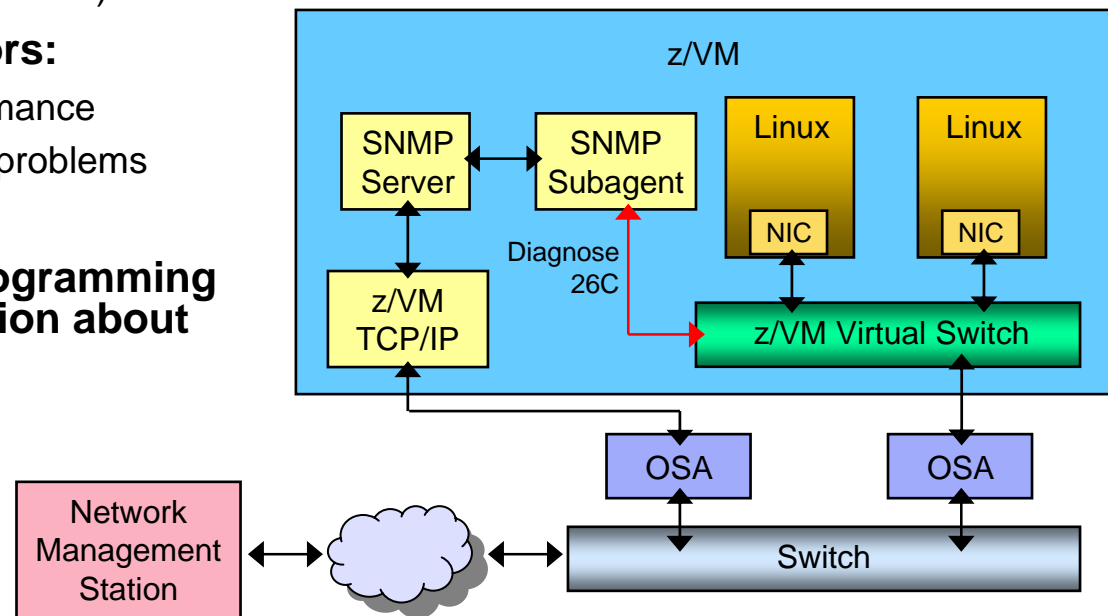

## Virtual Switch and Guest LAN Usability Enhancements

- **Dynamic change support for VLAN ID and promiscuous mode authorization**
  - Changes are effective immediately and no longer require a revoke, grant, and uncouple/couple to take effect
- **New capability to configure a native VLAN identifier**
  - Provides ability to specify a native VLAN identifier for untagged traffic and a default VLAN identifier for guest ports
  - The DEFINE VSWITCH command now supports specification of a native VLAN identifier
- **New virtual network monitor domain**
  - Virtual NIC data counts are now included in records found in a new Virtual Network monitor domain
  - Recorded data includes:
    - Inbound packets
    - Outbound bytes
    - Frame counts per MAC/VLAN
  - Provided for virtual NICs coupled to any Guest LAN or VSWITCH

# Additional z/VM Guest Support

- **ASCII console support**

- Allows the real System z ASCII console to be dedicated to a guest system
- Can facilitate recovery of a Linux guest system during an emergency situation
- Supports a VT220 data stream

- **Modified Indirect Data Address Words (MIDAW) support**

- Allows guest use of MIDAWs when z/VM is running on MIDAW-capable servers
- z/Architecture MIDAW facility offers an alternative to using CCW data chaining in channel programs
- May reduce channel, director, and control unit overhead by reducing number of CCWs and frames that have to be processed
- May improve I/O throughput, especially on faster FICON channels
- Allows z/OS guests to exercise their MIDAW support in a z/VM test environment

- **Program-directed IPL support**

- Enables a virtual machine to programmatically re-IPL using CCW-type or List-Directed (SCSI) IPL architectures
- Linux is the exploiter of this function
- Includes support to allow the setting and storing of IPL parameters

# Enhanced Failover Support for IPv4 and IPv6

- **Business Continuance support** – enables failover capability for the z/VM TCP/IP stack in the event of an adapter connection failure
- **Requires two QDIO or LAN Channel Station (LCS) Ethernet devices on the same network**
  - When one device stops or fails, the other device is designed to take over responsibility for the traffic destined for the failed device
- **Support includes:**
  - OSA-Express devices in QDIO Ethernet or LCS Ethernet mode
  - Virtual IP Addressing (VIPA)
  - Proxied addresses – those which PROXYARP services are being provided through a takeover-eligible device



# z/VM TCP/IP Support Enhancements

- **Virtual IP Addressing (VIPA) support for IPv6**
  - Enable and configure a virtual device for IPv6
  - Associate real IPv6-capable network adapters with a specific IPv6 virtual link
- **New Trace Route (TRACERTE) authorization**
  - Eliminates the restriction that TRACERTE can only be used by privileged users
  - TRACERTE is useful for anyone debugging networking issues
- **Dynamic DEVICE and LINK deletion support**
  - TCP/IP stack no longer has to be re-cycled to remove devices and links from the stack configuration
  - Programmatic access via C and REXX socket interface
- **SMTP**
  - Fixes SMTP processing of nickname files; improves host name resolution
  - Allows users to specify a nickname label in SMTP NAMES that matches any of the userids in the list defined by that nickname

# z/VM SSL Server Upgrade

## *Support for Additional Linux Distributions*

- **z/VM V5.3 SSL server will support the following Linux distributions:**
  - Novell SUSE Linux Enterprise Server (SLES) 10 (64-bit)
  - Novell SUSE Linux Enterprise Server (SLES) 9 Service Pack 3 (64-bit)
  - Novell SUSE Linux Enterprise Server (SLES) 9 Service Pack 3 (31-bit)
  - Red Hat Enterprise Linux (RHEL) AS 4 Update 4 (64-bit)
  - Red Hat Enterprise Linux (RHEL) AS 4 Update 4 (31-bit)
- **SSL server enhancements:**
  - Linux guests can remain active after a critical error is encountered during server operations
  - SSL server can more easily exclude weak cipher suites; helps support enterprise requirements for strong encryption on network connections (128 bits or higher)
- **SSLADMIN command has been enhanced to:**
  - Allow the specification of the number of days that a self-signed certificate is to be valid
  - Improve the management of the SSL server LOG files by providing the ability to:
    - Maintain log information in a file named other than SSLADMIN LOG
    - Specify a maximum size to be established for the SSL server log
    - Purge log information accumulated by the SSL server



## SSL / TLS Support

### *Conformance with Industry Standards*

- **z/VM V5.3 provides Secure Socket Layer / Transport Layer Security (SSL/TLS) support for:**
  - Industry-standard secure FTP (RFC 4217)
  - Telnet (draft specification #6)
  - SMTP sessions (RFC 3207)
- **New socket APIs control the acceptance and establishment of TCP sessions that are encrypted with SSL/TLS**
- **Data transmission on a connection can now begin in clear text and later switch to secure text**
  - Helps reduce the need to dedicate a separate port for secure connections

# Enhanced z/VM Systems Management Functions

## *For Allocating and Managing Guest Resources*

- **New sockets-based server interface for z/VM Systems Management API**
  - Multitasking capable and supports both AF\_INET and AF\_IUCV socket requests
  - Replaces the Remote Procedure Call (RPC) and CSL routines of prior z/VM releases
    - RPC server is still available at a function level that matches z/VM V5.2
    - IBM intends to remove the RPC server in a future z/VM release
- **New APIs available with new server include:**
  - Create, delete, and query the IPL statement in a virtual image's directory entry
  - Create and delete virtual switches and guest LANs
  - Obtain processor, memory, and device information for active virtual images
  - Check the validity of a given user ID and password combination
- **Enhancements to existing functions include:**
  - Exploitation of new Asynchronous CP Command function
  - Password phrase support
  - Providing a list of active virtual images
  - Architected output is provided for some query functions that previously returned command responses in a data buffer



# IBM Director for Linux on System z V5.20

- **New product announced November 14, 2006**
  - Program number 5648-DR1
  - Available since January 12, 2007 for z/VM V5.2 and V5.3
- **IBM Director V5.20 replaces the IBM Director V5.10 base function in the *IBM Virtualization Engine and Infrastructure Services for Linux on System z9 and zSeries* product**
- **Includes two optional, priced features**
  - IBM Director z/VM Center
  - IBM Director Software Distribution Premium Edition 
- **Other features still required from *IBM Virtualization Engine and Infrastructure Services for Linux on System z9 and zSeries* include:**
  - IBM Virtualization Engine Enterprise Workload Manager for Managing AIX, i5/OS, z/OS, Linux, and HP-UX Servers, V2.1
  - IBM Virtualization Engine Enterprise Workload Manager for Managing Solaris and Windows Servers, V2.1
  - IBM Resource Dependency Service, V2.1

Learn more at: [ibm.com/systems/management/director](http://ibm.com/systems/management/director)

# IBM Director for Linux on System z V5.20

## With z/VM Center and Software Distribution Premium Edition

### IBM Director Base Functions

- Discovery
- Group Management
- Inventory
- Basic Resource Monitor
- Event Action Plan (EAP)
- Process Management
- Remote Session
- File Transfer
- Network Configuration
- Software Distribution
- SNMP Browser

### z/VM Center

- Utility Service Configuration Manager **New**
- z/VM Virtual Server Deployment
- z/VM Server Complexes

### Software Distribution Premium Edition **New**

- SW package distribution

The screenshot displays the IBM Director Console interface. The main window is titled "IBM Director Console" and contains a menu bar (Console, Tasks, Associations, View, Options, Window, Help) and a toolbar with various icons. The central area is divided into two panes:

- Left Pane:** "Level 2: IBM Director Agents" showing a table of agents with columns for Name and TCP/IP Address. The table lists various agents such as BLD03-05, boeid101.boeblingen.de..., boeid102.boeblingen.de..., boeid104.boeblingen.de..., boeid107, boeid112.boeblingen.de..., boeid117.boeblingen.de..., boeid120.boeblingen.de..., boeid202.boeblingen.de..., boeid206.boeblingen.de..., boeid208.boeblingen.de..., boeid212.boeblingen.de.ib..., boeid217.boeblingen.de..., boeid218.boeblingen.de.ib..., boeid219.boeblingen.de.ib..., boeid220.boeblingen.de..., boerfc18.boeblingen.de..., boerfc19, boerfc22, boerfe16.boeblingen.de..., boerfe28.boeblingen.de..., and ID1HDE01.
- Right Pane:** "Tasks" showing a list of tasks including Asset ID, CIM Browser, Configure SNMP Agent, Event Action Plans, Event Log, External Application Launch, File Transfer, Hardware Status, Inventory, Microsoft Cluster Browser, Network Configuration, Process Management, Remote Control, Remote Session, Resource Monitors, Scheduler, SNMP Browser, Software Distribution, System Accounts, and Update Manager. The "z/VM Center" task is highlighted with a red box, and its sub-items, "Utility Service Configuration Manager", "z/VM Server Complexes", and "z/VM Virtual Server Deployment", are also visible.

The status bar at the bottom of the console shows "IBM Ready", "Host: 9.152.24.178", "User ID: root", and "24 objects".

# IBM Director V5.20 z/VM Center

- **Virtual Server Deployment – easy deployment of Linux servers on z/VM**
  - Create z/VM virtual machines using the IBM Director graphical user interface
  - Template-based provisioning of Linux virtual machines
- **Server Complexes – one-step provisioning of multiple Linux virtual servers**
  - Exploits Virtual Server Deployment task
  - Manages configuration settings of Linux virtual servers in order to reduce customization steps needed by Virtual Server Deployment
    - Definition of virtual networking, minidisk attachments
    - Supports configuration scripts
    - Controls virtual server resource assignment via z/VM Virtual Machine Resource Manager (VMRM)
- **Utility Service Configuration Manager **
  - New task that provides ease-of-use enhancements for installing and customizing Linux utility services
  - A utility service combines applications, configurations, and a system environment (e.g., network setup, storage) needed for a specific end-user function
  - Learn more about Linux utilities at: [ibm.com/systems/z/os/linux/utilities](http://ibm.com/systems/z/os/linux/utilities)
- **z/VM Center is priced on a per-managed processor basis**

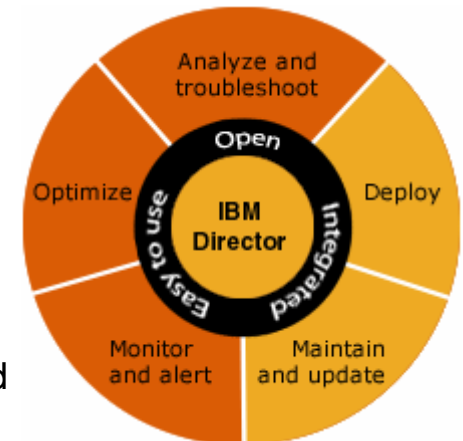

## IBM Director V5.20 Software Distribution Premium Edition

- **IBM Director includes a base level of software distribution**
  - It enables users to distribute IBM-provided software packages
- **Software Distribution Premium Edition allows users to build and distribute their own software packages for Director-managed systems**
- **Supported operating systems include:**
  - Linux
  - Windows
  - AIX
  - i5/OS
- **IBM Director Software Distribution Premium Edition is priced on a per server basis**
  - In the mainframe environment, a “server” is a mainframe model (e.g., 2094-S08) configured with any number of processors

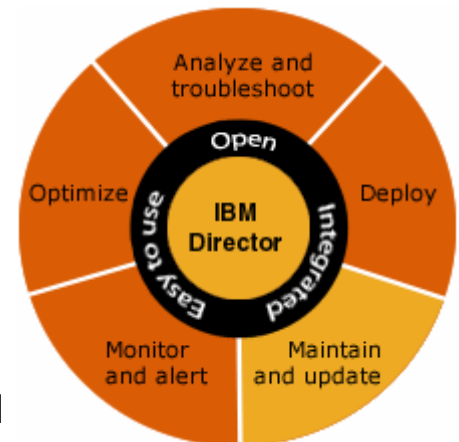



# Additional Virtual Server Infrastructure Support

## ■ User Directory Command support

- DIRECTXA supports a new COMMAND statement that specifies a command to be issued on behalf of a virtual machine during the logon process
- Commands may be associated with a directory profile; commands will be issued for each guest employing that profile
- Offers added flexibility and convenience for configuring large-scale virtual server environments

## ■ Asynchronous CP Command API

- Provides an asynchronous method to initiate CP commands for another userid and capture responses which are specific to those commands
- Introduces a new IUCV service (\*ASYNCMD) and a new CP command (FOR)
- The \*ASYNCMD system service allows CP command responses from the FOR command to be captured by a program
- The z/VM System Management API (SMAPI) server uses \*ASYNCMD
- A REXX exec using the "STARMSG" CMS Pipeline stage can capture the responses



# z/VM LDAP Server and Client Support Services

- **z/VM LDAP server is adapted from the z/OS 1.8 Tivoli Directory Server**
- **Executes in a CMS virtual machine; a subcomponent of z/VM TCP/IP**
- **Enables a common user name space between z/VM and Linux**
- **z/VM LDAP server provides:**
  - LDAP Version 2 and Version 3 protocol support
  - Interoperability with LDAP V2 or V3 protocol-capable clients
  - Native authentication using:
    - Challenge-Response Authentication Method (CRAM-MD5)
    - DIGEST-MD5 authentication
    - Simple (unencrypted) authentication
  - Access controls on directory information
  - SSL communication (SSL V3 and TLS V1)
  - Client and server authentication using SSL/TLS
- **LDAP client utilities provide a way to add, modify, search, and delete entries in any server that accepts LDAP protocol requests**
- **Interoperates with z/VM RACF Security Server Feature**



# Password Phrase Support

- **z/VM V5.3 supports use of passwords greater than 8 characters; requires presence of an external security manager (e.g., RACF)**
- **A “password phrase” may contain mixed-case letters, numbers, blanks, and special characters**
- **New Callable Services Library (CSL) routine, DMSPASS, allows authorized CMS applications to authenticate passwords or password phrases**
- **z/VM facilities that have been updated to support passphrases:**
  - LOGON command
  - TCP/IP File Transfer Protocol (FTP)
  - Systems Management API
  - Remote Execution Protocol (REXEC) server
  - Internet Message Access Protocol (IMAP) server
  - Performance Toolkit for VM
- **Support helps a z/VM system meet the enterprise password requirements imposed by many companies, governments, and institutions**
- **If passwords greater than 8 characters is not an option, RACF provides support for mixed-case 8-character passwords**

# RACF Security Server Enhancements

- **z/VM V5.3 RACF feature has been re-packaged and is now called “RACF Security Server for z/VM”**
  - Operates **only** with z/VM V5.3
- **Provides support for mixed-case passwords and password phrases**
  - RACF password phrases can be a string of up to 100 characters, including blanks; can be used in place of, or in addition to, traditional 8-character passwords
  - An installation exist is provided to help customers define rules for governing length and content of password phrases
- **Additional password management enhancements are included**
- **RACF SMF Unload utility has been updated to store unloaded data in industry-standard XML format**
  - Making the data suitable for examination by a variety of applications, including XML browsers and spreadsheets
- **IBM intends to withdraw the RACF for VM V1.10.0 standalone product from marketing effective March 5, 2007 (as announced December 5, 2006)**
- **IBM intends to discontinue service support for RACF for VM V1.10.0 effective May 8, 2008 (as announced February 6, 2007)**

Note: All statements regarding IBM's plans, directions, and intent are subject to change or withdrawal without notice, and represent goals and objectives only.

# z/VM Installation and Service Enhancements

- **Additional DVD installation option**
  - Users can install z/VM V5.3 in a virtual machine using DVD product installation files that have been moved to a CMS minidisk or FTP server directory
- **Enhanced support for automated SERVICE command**
  - Displays the service and production levels for preventative service (RSU)
  - Displays applied, built, and production status for corrective service
  - Can help users more quickly and easily determine service status



# Performance Toolkit for VM Enhancements

- **The Performance Toolkit for VM feature is a performance and reporting tool for the z/VM system and its guest images**
  - Real time and historical reporting
  - Offers threshold monitoring and user loop detection
  - Can monitor remote z/VM systems
  - Results can be viewed graphically with a web browser
- **z/VM V5.3 enhancements:**
  - Support for passphrases when accessing the Performance Toolkit using the Web interface
  - Service is by individual parts instead of module (reduces size of service deliverable)
  - New or updated displays and reports for new function:
    - Linux monitor data for CPU IDs and “steal time” counters
    - Monitor data for virtual network devices and virtual switches
    - Monitor data for guest simulation of zAAPs, zIIPs, and IFLs
    - Monitor data for up to 32 processors in a z/VM image
- **IBM Tivoli OMEGAMON XE for z/VM and Linux V4.1 requires the Performance Toolkit for VM for data collection**



## z/VM Statements of Direction

- IBM intends to evaluate [z/VM V5.3](#) with the RACF Security Server optional feature for conformance to the Controlled Access Protection Profile (CAPP) and Labeled Security Protection Profile (LSPP) of the Common Criteria standard for IT security, ISO/IEC 15408, at Evaluation Assurance Level 4 ([EAL4](#)). IBM no longer intends to evaluate z/VM V5.2.
- IBM intends to provide virtual switch (VSWITCH) support for IEEE Standard 802.3ad [Link Aggregation](#). This support requires associated OSA-Express2 support planned to be available on IBM System z9 servers.
- IBM intends to withdraw support for the [RPC/CSL interface](#) from the System Management API server in a future z/VM release.
- z/VM TCP/IP functions – IBM intends to withdraw support for the Network Database ([NDB](#)) system, Trivial File Transfer Protocol ([TFTP](#)) server, [X.25](#) interface (includes X25IBI server), and [SNALINK](#) server in a future z/VM release.
- IBM intends to withdraw [3480 tape as a distribution media](#) in a future z/VM release.

Note: All statements regarding IBM's plans, directions, and intent are subject to change or withdrawal without notice, and represent goals and objectives only.

# Linux and z/VM on System z

## *Business Value Propositions for Linux Workloads*

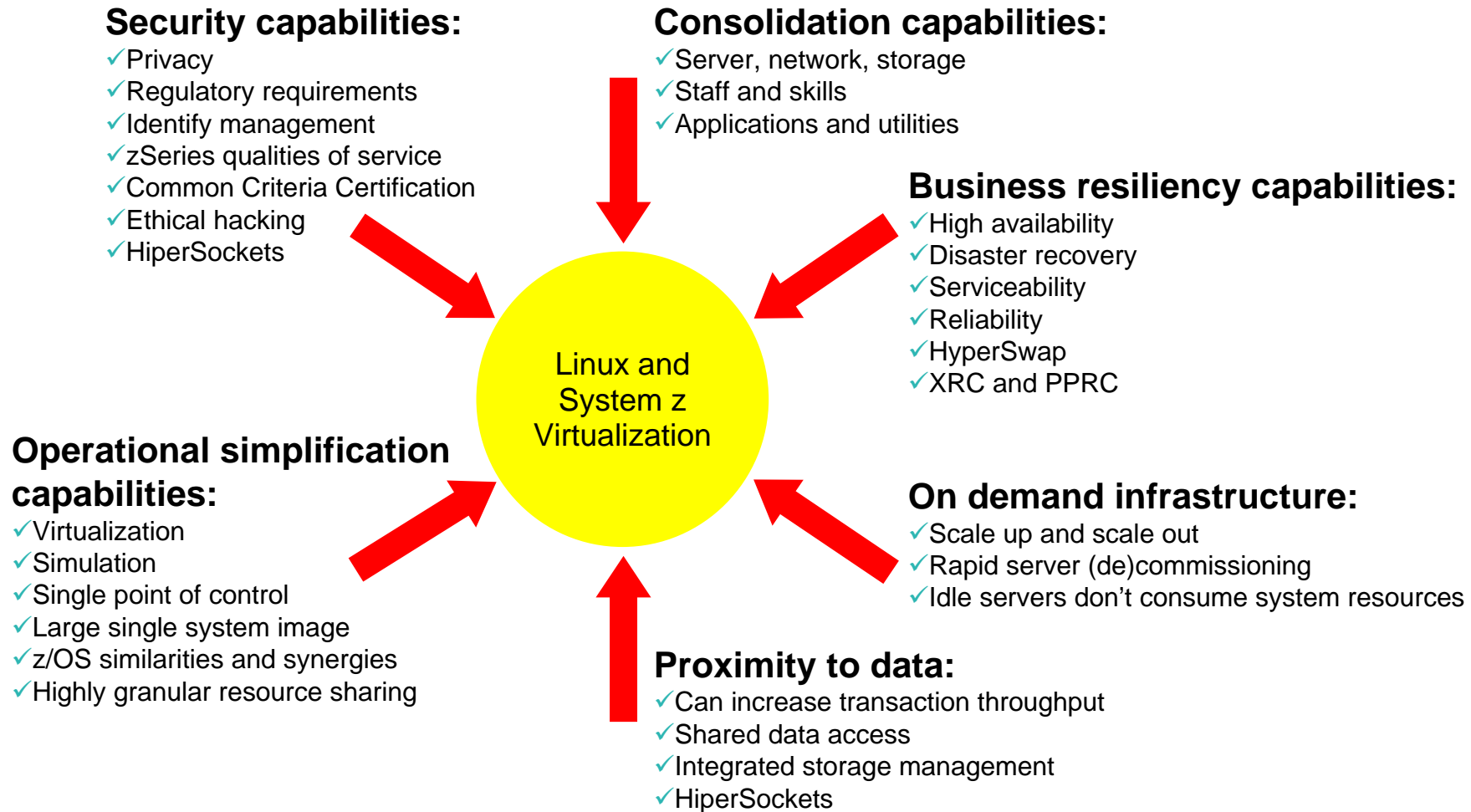



**Thank you**

**For more information, please contact**

**Erich Amrehn**

**amrehn@de.ibm.com**

**+49 7031162512**

**[ibm.com/systems/z](http://ibm.com/systems/z)**

