

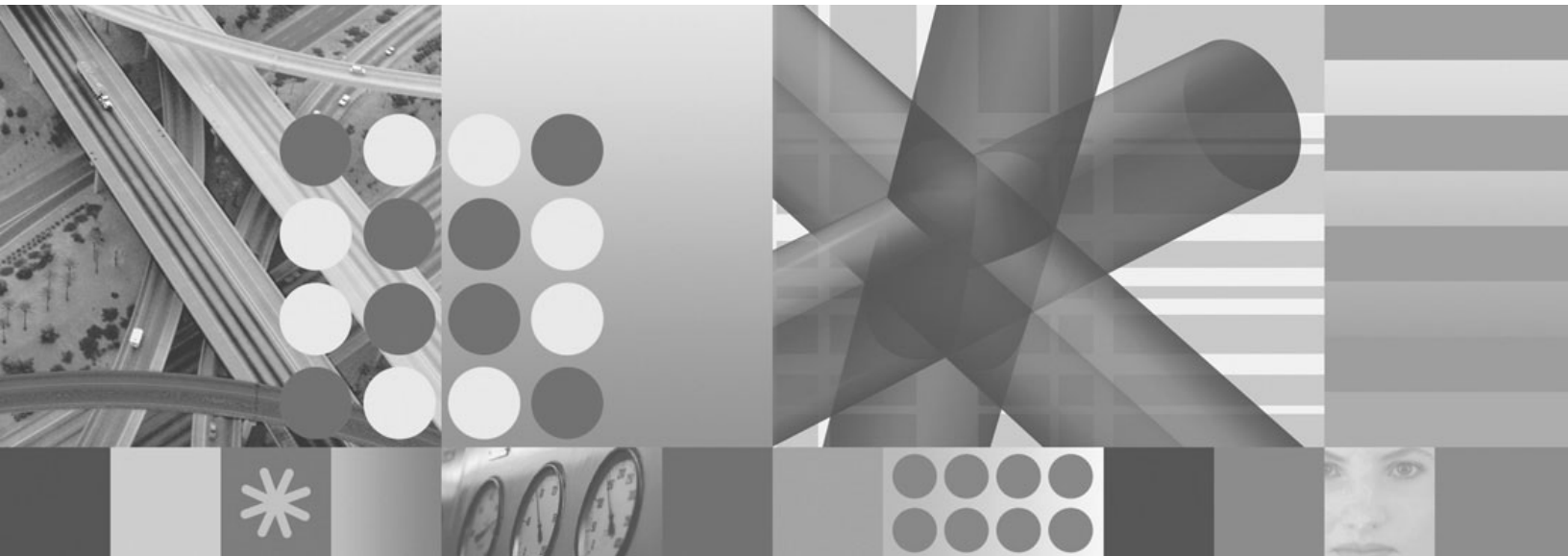

Programmer's Reference



Programmer's Reference

Note!

Before using this information and the product it supports, read the information in "Notices" on page ix.

This edition applies to IBM Tivoli System Automation for z/OS (5698-SA3) Version 3 Release 2, an IBM licensed program, and to all subsequent releases and modifications until otherwise indicated in new editions.

Order publications through your IBM representative or the IBM branch office serving your locality. Publications are not stocked at the address given below.

A form for readers' comments appears at the back of this publication. If the form has been removed, address your comments to:

IBM Deutschland Entwicklung GmbH
Department 3248
Schoenaicher Strasse 220
D-71032 Boeblingen
Federal Republic of Germany

FAX: (Germany): 07031+16-3456

FAX: (Other countries): (+49)+7031-16-3456

Internet e-mail: s390id@de.ibm.com

When you send information to IBM, you grant IBM a nonexclusive right to use or distribute the information in any way it believes appropriate without incurring any obligation to you.

© Copyright International Business Machines Corporation 1996, 2007. All rights reserved.

US Government Users Restricted Rights – Use, duplication or disclosure restricted by GSA ADP Schedule Contract with IBM Corp.

Contents

Figures	v	INGVSTRT	87
Tables	vii	INGVSTOP	88
Notices	ix	MDFYSHUT	90
Programming Interface Information.	x	Chapter 3. Monitoring Routines	93
Trademarks.	x	AOFADMON.	93
Accessibility	xi	AOFAPMON.	94
Using assistive technologies	xi	AOFATMON.	94
Keyboard navigation of the user interface	xi	AOFPCPSM.	95
z/OS information	xi	AOFNCMON.	95
About This Book	xiii	AOFUXMON.	96
Who Should Use This Book.	xiii	INGPJMON	97
Where to Find More Information	xiii	INGPSMON	98
Summary of Changes for SC33-8266-03	xiv	INGVMON	99
Part 1. Introduction	1	ISQMTSYS	100
Chapter 1. Introduction	3	Chapter 4. Generic Routines	101
Overview of Commands	3	Using SA z/OS Generic Routines for Programming	101
Format of Syntax Diagrams	3	ACTIVMSG	101
Part 2. SA z/OS System Operations Routines	5	AOCFILT.	104
Chapter 2. Common Routines	7	AOFPCPSMG.	105
Using System Operations Common Routines for		AOFRCMTR.	108
Programming	7	FWDMSG	108
ACF	7	HALTMSG	110
ACFCMD	12	INGMON	112
ACFFQRY	20	ISSUEACT (ISSUECMD, ISSUEREP).	118
ACFREP	26	OUTREP	125
AOCGETCN	33	TERMMMSG	127
AOCMSG	34	Chapter 5. Utilities	133
AOCQRES.	40	AOFRACON	133
AOCQRY	41	INGALERT	134
AOCUPDT	52	INGCPSM	136
AOFEXCMD	56	INGDATA	137
AOFSET	57	INGLINK	139
AOFTREE	58	INGMTRAP.	142
ASF	62	INGOMX.	143
ASFUSER	67	INGSIT	150
CDEMATCH	70	INGSTOBS	153
CHKSUBS.	73	INGSTX	155
CHKTHRES	73	INGTIMER	159
INGCNTL	76	INGVAR	162
INGPOST	78	INGVTAM	164
INGQRY	81	Chapter 6. ING\$QRY NetView	
INGRCLUP	82	Automation Table Function	167
INGRTCMD	83	ING\$QRY	167
INGUSS	83	Part 3. SA z/OS I/O Operations	
		Commands.	171
		Chapter 7. I/O Operations Commands	
		(API)	173

Using I/O Operations Commands for Programming	173
Safe Switching	175
FICON Switches	175
FICON Cascaded Switches	175
Common Elements	176
DELETE FILE	189
QUERY ENTITY CHP	189
QUERY ENTITY CNTLUNIT	195
QUERY ENTITY DEV	198
QUERY ENTITY HOST	200
QUERY ENTITY SWITCH	203
QUERY FILE	206
QUERY INTERFACE CNTLUNIT.	207
QUERY INTERFACE SWITCH	212
QUERY RELATION CHP	219
QUERY RELATION CNTLUNIT	220
QUERY RELATION DEV	220
QUERY RELATION HOST	221
QUERY RELATION SWITCH	222
QUERY SWITCH	223
REMOVE and RESTORE CHP.	226
REMOVE DEV and RESTORE DEV	229
WRITEFILE	235
WRITEPORT	236
WRITESWCH	241

Chapter 8. Invoking I/O Operations with a REXX EXEC	249
Rules for Calls by a REXX EXEC	249

Part 4. Status Display Facility Definitions 257

Chapter 9. SDF Initialization Parameters	259
---	------------

DCOLOR.	259
DPFKnn	260
DPFKDESC1	261
DPFKDESC2	262
EMPTYCOLOR.	263
ERRCOLOR.	263
INITSCRN	264
MAXOPS.	265
PFKnn.	265
PRIORITY	266
PRITBSZ	269
PROPDOWN	269
PROPUP	270
SCREENSZ	270
TEMPERR	270

Chapter 10. SDF Definition Statements 273

AOFTREE	273
PANEL	276
STATUSFIELD	277
STATUSTEXT	280
TEXTFIELD	281
TEXTTEXT	283
PFKnn.	283
ENDPANEL.	285
Example SDF Definition.	285

Chapter 11. SDF Commands 293

SDFTREE.	293
SDFPANEL	294
SCREEN	295

Glossary 299

Index 319

Figures

1.	DISPACF Command Response Panel	17	13.	Example Tree Structure Definitions: System SY1	275	
2.	Subsystem Dependent Tree	59	14.	Example Tree Structure Definitions: System SY2	275	
3.	Code Processing Sample Panel	72	15.	SDF Example: Tree Structure Definition for SY1	286	
	4.	Thresholds Definition Panel for TSO Subsystem	75	16.	SDF Example: Hierarchy Defined by SY1 Tree Structure	286
	5.	DISPACF Sample Panel	123	17.	SDF Example: System Panel Definition Statements	287
	6.	Code Processing Panel for an Application Resource	126	18.	SDF Example: Status Component Panel Definition Statements for SY1SYS	289
	7.	Code Processing Panel for the MVSESA Resource	126	19.	Sample SY1 SDF Panel	290
	8.	DISPACF Command Dialog Panel	131	20.	Default Values for SDF Displays	292
	9.	Exits and Associated Resources	155			
	10.	INGVARS Command Line-Mode Output	163			
	11.	INGVTAM REQ=LIST Output	165			
	12.	QUERY SWITCH Command - Sample Output	226			

Tables

1. System Automation for z/OS Library	xiii	13. QUERY ENTITY DEV Output	198
2. Overview of Commands	3	14. QUERY ENTITY HOST Output	201
3. Output from ACFFQRY	22	15. QUERY ENTITY SWITCH Output	204
4. AOCQRY Subsystem Task Global Variables	45	16. QUERY FILE Output of a Particular Configuration	207
5. AOCQRY Parent Task Global Variables	46	17. QUERY INTERFACE CNTLUNIT Output	208
6. AOCQRY Automation Flag Task Global Variables	48	18. QUERY INTERFACE SWITCH Output	213
7. TERMMSG Status Transitions	127	19. QUERY SWITCH Output	223
8. Standard SA z/OS Array Format	178	20. REMOVE DEV and RESTORE DEV Output	233
9. Header for all Query Entity/Interface Output Formats	183	21. WRITEFILE Input Format	236
10. Output Format of all Query Relation Commands	184	22. WRITESWCH Input	242
11. QUERY ENTITY CHP Output	190	23. Variables for the DPFknn Command	261
12. QUERY ENTITY CNTLUNIT Output	195	24. Variables for the PFKnn Command	266
		25. Variables for PF Keys	284

Notices

This information was developed for products and services offered in the U.S.A.

IBM may not offer the products, services, or features discussed in this document in other countries. Consult your local IBM representative for information on the products and services currently available in your area. Any reference to an IBM product, program, or service is not intended to state or imply that only that IBM product, program, or service may be used. Any functionally equivalent product, program, or service that does not infringe any IBM intellectual property right may be used instead. However, it is the user's responsibility to evaluate and verify the operation of any non-IBM product, program, or service.

IBM may have patents or pending patent applications covering subject matter in this document. The furnishing of this document does not give you any license to these patents. You can send license inquiries, in writing, to:

IBM Director of Licensing
IBM Corporation
North Castle Drive
Armonk, NY 10504-1785
USA

Licensees of this program who wish to have information about it for the purpose of enabling: (i) the exchange of information between independently created programs and other programs (including this one) and (ii) the mutual use of the information which has been exchanged, should contact:

IBM Deutschland Entwicklung GmbH
Department 3248
Schoenaicher Strasse 220
D-71032 Boeblingen
Federal Republic of Germany

Such information may be available, subject to appropriate terms and conditions, including in some cases, payment of a fee.

The following paragraph does not apply to the United Kingdom or any other country where such provisions are inconsistent with local law: INTERNATIONAL BUSINESS MACHINES CORPORATION PROVIDES THIS PUBLICATION "AS IS" WITHOUT WARRANTY OF ANY KIND, EITHER EXPRESS OR IMPLIED, INCLUDING, BUT NOT LIMITED TO, THE IMPLIED WARRANTIES OF NON-INFRINGEMENT, MERCHANTABILITY OR FITNESS FOR A PARTICULAR PURPOSE. Some states do not allow disclaimer of express or implied warranties in certain transactions, therefore, this statement may not apply to you.

This information could include technical inaccuracies or typographical errors. Changes are periodically made to the information herein; these changes will be incorporated in new editions of the publication. IBM may make improvements and/or changes in the product(s) and/or the program(s) described in this publication at any time without notice.

Any references in this information to non-IBM Web sites are provided for convenience only and do not in any manner serve as an endorsement of those Web sites. The materials at those Web sites are not part of the materials for this IBM product and use of those Web sites is at your own risk.

If you are viewing this information softcopy, the photographs and color illustrations may not appear.

Programming Interface Information

This book documents programming interfaces that allow the customer to write programs to obtain the services of System Automation for z/OS.

Trademarks

The following terms, used in this book, are trademarks of the IBM Corporation in the United States or other countries:

CICS	DB2	ESCON
FICON	IBM	IMS
MVS	MVS/ESA	NetView
OMEGAMON	OS/390	RACF
RMF	Tivoli	VTAM
z/OS		

The following terms are trademarks of other companies:

- UNIX is a registered trademark of The Open Group in the United States and other countries.

Accessibility

Accessibility features help a user who has a physical disability, such as restricted mobility or limited vision, to use software products successfully. The major accessibility features in z/OS™ enable users to:

- Use assistive technologies such as screen readers and screen magnifier software
- Operate specific or equivalent features using only the keyboard
- Customize display attributes such as color, contrast, and font size

Using assistive technologies

Assistive technology products, such as screen readers, function with the user interfaces found in z/OS. Consult the assistive technology documentation for specific information when using such products to access z/OS interfaces.

Keyboard navigation of the user interface

Users can access z/OS user interfaces using TSO/E or ISPF. Refer to *z/OS TSO/E Primer*, *z/OS TSO/E User's Guide*, and *z/OS ISPF User's Guide Vol I* for information about accessing TSO/E and ISPF interfaces. These guides describe how to use TSO/E and ISPF, including the use of keyboard shortcuts or function keys (PF keys). Each guide includes the default settings for the PF keys and explains how to modify their functions.

z/OS information

z/OS information is accessible using screen readers with the BookServer/Library Server versions of z/OS books in the Internet library at:

<http://www.ibm.com/servers/eserver/zseries/zos/bkserv/>

About This Book

This book describes the programming interfaces of IBM® Tivoli® System Automation for z/OS (SA z/OS). It provides detailed reference material you need to operate, maintain and program for SA z/OS.

The sample material in this book is based on SA z/OS running on NetView® V1R4.

Throughout this publication references to MVS™ refer either to MVS/ESA™, or to the MVS element of z/OS.

Who Should Use This Book

This information is primarily for system programmers and automation programmers, but may also be useful for others, for example, help desk personnel and customer engineers.

Where to Find More Information

The System Automation for z/OS Library

The following table shows the information units in the System Automation for z/OS library:

Table 1. System Automation for z/OS Library

Title	Order Number
<i>IBM Tivoli System Automation for z/OS Planning and Installation</i>	SC33-8261
<i>IBM Tivoli System Automation for z/OS Customizing and Programming</i>	SC33-8260
<i>IBM Tivoli System Automation for z/OS Defining Automation Policy</i>	SC33-8262
<i>IBM Tivoli System Automation for z/OS User's Guide</i>	SC33-8263
<i>IBM Tivoli System Automation for z/OS Messages and Codes</i>	SC33-8264
<i>IBM Tivoli System Automation for z/OS Operator's Commands</i>	SC33-8265
<i>IBM Tivoli System Automation for z/OS Programmer's Reference</i>	SC33-8266
<i>IBM Tivoli System Automation for z/OS CICS Automation Programmer's Reference and Operator's Guide</i>	SC33-8267
<i>IBM Tivoli System Automation for z/OS IMS Automation Programmer's Reference and Operator's Guide</i>	SC33-8268
<i>IBM Tivoli System Automation for z/OS TWS Automation Programmer's Reference and Operator's Guide</i>	SC23-8269
<i>IBM Tivoli System Automation for z/OS End-to-End Automation Adapter</i>	SC33-8271
<i>IBM Tivoli System Automation for z/OS Monitoring Agent Configuration and User's Guide</i>	SC33-8337

The System Automation for z/OS books are also available on CD-ROM as part of the following collection kit:

IBM Online Library z/OS Software Products Collection (SK3T-4270)

SA z/OS Home Page

For the latest news on SA z/OS, visit the SA z/OS home page at <http://www.ibm.com/servers/eserver/zseries/software/sa>

Related Product Information

You can find books in related product libraries that may be useful for support of the SA z/OS base program by visiting the z/OS Internet Library at <http://www.ibm.com/servers/eserver/zseries/zos/bkserv/>

Using LookAt to look up message explanations

LookAt is an online facility that lets you look up explanations for most of the IBM messages you encounter, as well as for some system abends and codes. Using LookAt to find information is faster than a conventional search because in most cases LookAt goes directly to the message explanation.

You can use LookAt from these locations to find IBM message explanations for z/OS elements and features, z/VM[®], VSE/ESA[™], and Clusters for AIX[®] and Linux[™]:

- The Internet. You can access IBM message explanations directly from the LookAt Web site at <http://www.ibm.com/servers/eserver/zseries/zos/bkserv/lookat/>.
- Your z/OS TSO/E host system. You can install code on your z/OS or z/OS.e systems to access IBM message explanations using LookAt from a TSO/E command line (for example: TSO/E prompt, ISPF, or z/OS UNIX[®] System Services).
- Your Microsoft[®] Windows[®] workstation. You can install LookAt directly from the *z/OS Collection* (SK3T-4269) or the *z/OS and Software Products DVD Collection* (SK3T4271) and use it from the resulting Windows graphical user interface (GUI). The command prompt (also known as the DOS > command line) version can still be used from the directory in which you install the Windows version of LookAt.
- Your wireless handheld device. You can use the LookAt Mobile Edition from <http://www.ibm.com/servers/eserver/zseries/zos/bkserv/lookat/lookatm.html> with a handheld device that has wireless access and an Internet browser (for example: Internet Explorer for Pocket PCs, Blazer or Eudora for Palm OS, or Opera for Linux handheld devices).

You can obtain code to install LookAt on your host system or Microsoft Windows workstation from:

- A CD-ROM in the *z/OS Collection* (SK3T-4269).
- The *z/OS and Software Products DVD Collection* (SK3T4271).
- The LookAt Web site (click **Download** and then select the platform, release, collection, and location that suit your needs). More information is available in the LOOKAT.ME files available during the download process.

Summary of Changes for SC33-8266-03

This document contains information previously presented in System Automation for z/OS V3R1.0 Programmer's Reference, SC33-8266-02, which supports z/OS Version 1 Release 7.

New Information

AOFNCMON Monitoring Routine

The AOFNCMON routine is used to determine the status of the NETCONV connection running between the NMC server and z/OS NetView. For more details see “AOFNCMON” on page 95.

INGLINK System Utility

The INGLINK utility lets you activate and deactivate links between consumer and provider applications that are defined as dynamic links in the automation policy, and query the status of those links. For more details see “INGLINK” on page 139.

INGQRY Common Routine

The INGQRY common routine returns the value of a specified attribute for a particular resource. For more details see “INGQRY” on page 81.

ISSUEACT Generic Routine

ISSUEACT, ISSUECMD and ISSUEREP are defined as synonyms for the same generic routine, which can be used to trigger your own commands, replies, or both, from messages that are defined in the automation policy item MESSAGES/USER DATA. For more details see “ISSUEACT (ISSUECMD, ISSUEREP)” on page 118.

ING\$QRY, NetView Automation Table Function

SA z/OS provides a NetView automation-table function (ATF) program, called ING\$QRY, that allows you to query or compare the status and other important attributes of jobs that are controlled by SA z/OS from within the AT and use the result as a condition in the AT statement. For more details see Chapter 6, “ING\$QRY NetView Automation Table Function,” on page 167.

Changed Information

WAIT Parameter for INGSTOBS Command

A WAIT parameter has been added to the INGSTOBS command. It controls how long to wait until the automation manager has processed a request when sending a subscription request to the automation manager. For more details see “INGSTOBS” on page 153.

Return Codes for ACF Command

The return codes have been listed for the ACF command. For more details see “ACF” on page 7.

You may notice changes in the style and structure of some content in this document—for example, headings that use uppercase for the first letter of initial words only, and procedures that have a different look and format. The changes are ongoing improvements to the consistency and retrievability of information in our documents.

This document contains terminology, maintenance, and editorial changes. Technical changes or additions to the text and illustrations are indicated by a vertical line to the left of the change.

Part 1. Introduction

Chapter 1. Introduction	3	Format of Syntax Diagrams	3
Overview of Commands	3		

This part describes System Automation for z/OS commands in general—how to enter them, the format, and the various types of commands.

Chapter 1. Introduction

Overview of Commands

Table 2 gives a brief overview of the System Automation for z/OS commands. This overview lists the various types of commands, their functions and where they can be entered.

Table 2. Overview of Commands

Type of command	Function	Where entered	Notes
System operations commands			
	Control and maintain resources in the enterprise from a single point of control	NetView console, or NMC	
I/O operations commands			
	Control input/output devices	TSO/ISPF, API, operator console	
Processor operations commands			
	Common commands for automation	API, NetView console, or NMC	Precede with ISQCCMD command
	Control hardware processors	NetView console or NMC	

Format of Syntax Diagrams

The description of each command and routine includes the format of the command in a syntax diagram. The diagram shows the operands for the commands. Use blanks to separate the operands, unless otherwise stated or diagrammed.

To construct a command from the diagram, follow the diagram from left to right, choosing the path that suits your needs. Following is a sample syntax diagram that explains how to use it to construct a command. This command is for illustration only. Do not attempt to enter it.

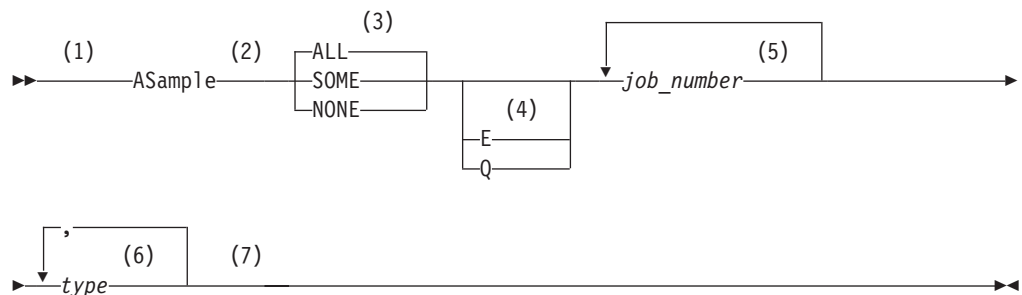

Notes:

- 1 Start here. ►► indicates the start of the diagram.

- 2 Type ASAMPLE, or abbreviate to AS. The uppercase characters are the abbreviation. Operands on the main line are required.
- 3 Choose one of the options. The default is always above the main line. In this case, ALL is the default. If the option includes punctuation marks, include them too: =(), .
- 4 Choose E, Q, or neither. Operands below the main line are optional.
- 5 Repeat *job_number* any number of times. Variables are shown in italics. Replace them with a real name or value.
- 6 Repeat *type* any number of times, separated with a comma. Variables are shown in italics. Replace them with a real name or value.
- 7 End here. →◀ indicates the end of the command.

If a command continues to the next line, you see → and ▶-.
|and| indicates a fragment for a specific condition or option.

Examples:

```
====> asample none q DAF00821 DAF00832 ELD00824  
====> as some DLR01445
```

Part 2. SA z/OS System Operations Routines

Chapter 2. Common Routines	7	INGPJMOM	97
Using System Operations Common Routines for		INGPSMON	98
Programming	7	INGVMON	99
ACF	7	ISQMTSYS	100
ACFCMD	12		
ACFFQRY	20	Chapter 4. Generic Routines	101
ACFREP	26	Using SA z/OS Generic Routines for Programming	101
AOCGETCN	33	ACTIVMSG	101
AOCMSG	34	AOCFLT	104
AOCQRES	40	AOFCPSM	105
AOCQRY	41	AOFRCMTR	108
AOCUPDT	52	FWDMSG	108
AOFEXCMD	56	HALTMSG	110
AOFSET	57	INGMON	112
AOFTREE	58	ISSUEACT (ISSUECMD, ISSUEREP)	118
ASF	62	OUTREP	125
ASFUSER	67	TERMMSG	127
CDEMATCH	70		
CHKSUBS	73	Chapter 5. Utilities	133
CHKTHRES	73	AOFRACON	133
INGCNTL	76	INGALERT	134
INGPOST	78	INGCPSM	136
INGQRY	81	INGDATA	137
INGRCLUP	82	INGLINK	139
INGRTCMD	83	INGMTRAP	142
INGUSS	83	INGOMX	143
INGVSTRT	87	INGSIT	150
INGVSTOP	88	INGSTOBS	153
MDFYSHUT	90	INGSTX	155
		INGTIMER	159
Chapter 3. Monitoring Routines	93	INGVARS	162
AOFADMON	93	INGVTAM	164
AOFAPMON	94		
AOFATMON	94	Chapter 6. ING\$QRY NetView Automation Table	
AOFPCSM	95	Function	167
AOFNCMON	95	ING\$QRY	167
AOFUXMON	96		

This part describes System Automation for z/OS common commands—specifics of how to enter them and their format.

Refer to *IBM Tivoli System Automation for z/OS User's Guide* for general information about SA z/OS commands.

Chapter 2. Common Routines

Using System Operations Common Routines for Programming

SA z/OS provides common and generic routines for use in automation procedures. Common and generic routines are convenient routines that provide your automation procedures with a simple, standard way of interfacing with the automation control file, the automation status file, and the NetView log file. It is strongly recommended that you use these routines wherever possible in your own code.

Common routines are programming building blocks that you must incorporate into your script, whereas generic routines are complete routines that you can call from Network Communications Control Facility (NCCF), the NetView automation table (AT) or script without further programming.

Using common and generic routines in automation procedures provides you with the following advantages:

- Reduced development time—less code has to be written
- Portable code—automation policy information that is unique to an enterprise can be kept in the automation control file rather than distributed among many automation procedures. The automation procedures implement a number of different rules for handling a situation and the automation control file is used to select which rules are applicable to the current situation.
- A consistent, documented interface

Refer to Chapter 4, “Generic Routines,” on page 101 for further information on how to use generic routines.

ACF

Purpose

The ACF command loads, displays, and modifies automation control file entries.

For modification and display actions to work, the automation control file must be loaded into storage. Once loaded, the displays and modifications affect an in-storage version of the automation control file, allowing you to make *temporary* changes. To make permanent changes, change the automation policy using the customization dialogs, generate the automation control file member, then reload the new version using INGAMS.

Alternatively, temporary changes to the automation control file can be made semi-permanent by saving the automation environment to a warm start cache with the ACF SAVE command. This enables your changes to be restored on a subsequent warm start. It is recommended that you change the associated policy using the customization dialogs to ensure that the policy is applied upon a cold start.

See also the related command, “ACFFQRY” on page 20.

Recommendations

- Changes to automation policy using the SA z/OS command dialogs, or the ACF command are temporary. They modify the current in-storage version of the automation control file directly. They do not modify the automation control file stored on disk. The ACF SAVE command can be used to save any changes to a warm start cache for subsequent restoration using the ACF WARM command, or warm start. To change an automation policy setting permanently, make sure you also change the automation control file (using the customization dialogs) stored on disk.
- If the customization dialogs are used to rebuild the policy on disk, the changed data on disk will replace the data in storage at ACF REFRESH. It will also replace the data on CACHE if you specify the SAVE option.
- Use scope-checking to limit operator use of ACF to loading, saving and display operations.

Syntax

The following syntax diagrams show how to use the ACF command to perform the different functions ACF supports. Do not combine syntax from the separate diagrams in the same ACF call.

To display information in the automation control file use the following syntax:

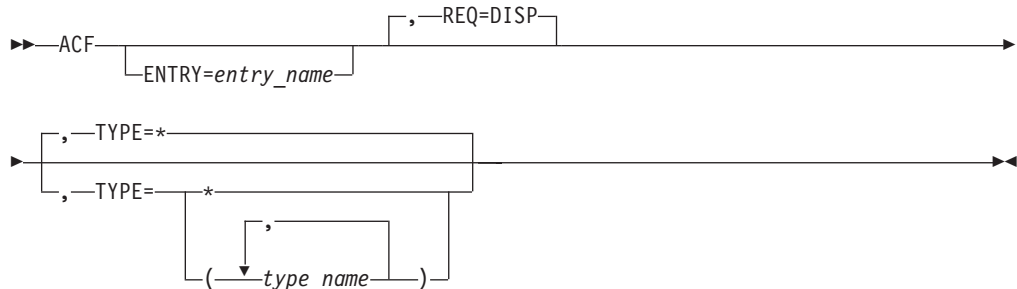

To delete information in the automation control file use the following syntax:

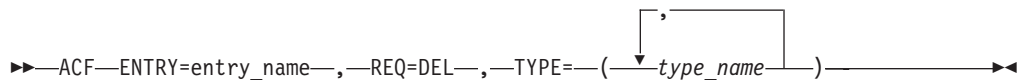

To replace or add information in the automation control file use the following syntax:

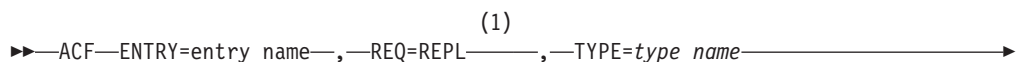

**Notes:**

- 1 Use this syntax when the ACF data are passed to the ACF command via the NetView default safe.

Note: The ACF command is free-form: commas are optional; more than one space can separate keywords; keywords can be specified in any sequence; any parameters specified must follow the keyword that they apply to.

Parameters**REQ=**

The type of request for automation control file information the ACF command performs. This value can be one of the following:

Value	Description
-------	-------------

DISP

Displays information in the automation control file. This value is the default if this parameter is not coded.

DEL

Deletes information in the automation control file. This value must be coded when using ACF to delete automation control file information.

REPL

Replaces or adds information in the automation control file. This value must be coded when using ACF to replace automation control file information. REPL adds the entry specified on the ENTRY parameter if the entry does not already exist in the automation control file.

REQ=REPL will update data in place. That is, only data that is to be replaced needs to be specified in the command. All other existing data will be retained.

ENTRY=

The entry field of the automation control file. This value can be up to 32 characters long, without imbedded blanks, commas, or quotes.

If information in the automation control file is displayed (REQ=DISP), and no value is specified in the entry field, ENTRY=* is used.

TYPE=

The type field in the automation control file. The following values can be specified:

- * Specifying * returns all type fields associated with a given *entry_name*, for example, all SUBSYSTEM or NTFYOP entries. * is the default value when REQ=DISP (display). REQ=DISP supports the use of * as a wildcard character when specifying type names, with the following restrictions:
 - The wildcard character, '*', must be the last character in the type name. If an asterisk appears in any other position in a type name then it will be treated as a literal. If an asterisk appears in any other position in a type name with an asterisk as the last character then no wildcard processing occurs and *both* asterisks are treated as literals.

- If you update an entry, you must specify the ENTRY= operand without a wildcard.
- If no matches are found, a final search is performed with a type name of DEFAULTS.

For other ACF request types (delete and replace), you must specify an actual type name.

type_name

The name of the type field. REQ=REPL requests allow you to enter only one *type_name*.

When ENTRY=SUBSYSTEM, *type_name* can be up to 11 bytes long. In all other cases, *type_name* can be up to 32 characters long, without imbedded blanks, commas, or quotes.

(type_name,type_name,...)

Multiple types may be specified for DISP and DEL requests. Type names should be enclosed in parentheses and separated by commas. For REQ=DISP, only the first type name found is displayed. For REQ=DEL requests, all the type names will be deleted.

parms=value

The data associated with the specified ENTRY and TYPE fields. This field is valid only with the REQ=REPL option. Specify this field as the parameter value, an equal (=) sign, and the value, without any spaces in between; for example, AUTO=NO.

The value can be any character data. It can have imbedded quotes, commas, and blanks, provided that single quotes or parentheses frame the value.

SA z/OS defines several ENTRY, TYPE, and parms=value fields. A parms=value example is the JOB=jobname parameter in the SUBSYSTEM automation control file entry.

Note: REQ=REPL will update data in place. That is, only modified data is updated. All data will be retained.

Restrictions and Limitations

The ACF command should be used with care to change or delete automation policy settings. Temporary changes can be saved to a warm start cache. Changes saved to a warm start cache are restored upon a warm start or an ACF WARM command.

ACF is used as an API to the automation control file. It could also be used as an operator command, for example, ACF STATUS, to get information about the automation control file. For further information about ACF as an operator's command refer to *IBM Tivoli System Automation for z/OS Operator's Commands*.

The number of entries in the automation control file is limited only by the amount of storage in the SA z/OS address space or region. If you have a very large configuration, you may have to increase the REGION size in the SA z/OS procedure.

The size of the pre-allocated Save/Restore database is the only limiting factor in saving an automation environment. Ensure that secondary extents are defined. See *NetView Administration Guide* for more information on defining Save/Restore databases.

Not all data can be changed using ACF REQ=REPL, for example, service periods, events, triggers, dependencies and groups cannot be changed. ACF REQ=DEL and ACF REQ=REPL cannot be used to add or delete a subsystem. Use the customization dialogs to define these items.

Changes to System Defaults and Application Defaults are not propagated to the instances that have inherited this data.

Return Codes

- 0 Function completed successfully.
- 1 Control file inactive.
- 3 ACF token mismatch.
- 4 Invalid parameters were used in the call.
- 12 No valid ACF member available.
- 20 ACF reload not allowed by automation flag settings.
- 28 The cache is unusable.
- 100 Other error.

Usage

- When you use ACF REQ=DISP to request a certain ENTRY value with one or more specific TYPE values, ACF searches for those types in the order specified in the command. When the first match is found, the information is returned to the requester as a multiline message. If there are no matches, it performs a final search with a type_name of DEFAULTS for that ENTRY value. If there is still no match, a message is returned to the requester. If the type_name DEFAULTS is found, that information is returned to the requester.
- When ACF is used to display an automation control file entry, if a specific TYPE is found, it is treated as a complete entry. Only that specific entry is displayed.

Messages

The following lists messages that are issued during the operation of ACF.

For the delete and replace function:

```
AOF001I REQUEST REPL SUCCESSFUL FOR JES2-$HASP098
```

Note: In a display where the type_name is * (asterisk), multiple sets of AOF112I and AOF113I messages may be displayed. When the type is omitted or specified as *, the DESIRED TYPE is not displayed on the AOF112I message.

For the display function:

```
AOF041I UNABLE TO FIND type_name entry_name
AOF111I AUTOMATION CONFIGURATION DISPLAY - ENTRY= entry_name
AOF112I ACTIVE TYPE= act_type, DESIRED TYPE= desired_type ...
AOF113I DATA IS data=value
AOF002I END OF MULTILINE MESSAGE
```

For example, the following may occur:

ACF

```
AOF111I AUTOMATION CONFIGURATION DISPLAY - ENTRY= NTFYOP
AOF112I ACTIVE TYPE= NETOP1
AOF113I DATA IS OPER='OPER 1'
AOF113I DATA IS CLASS=(10,40)
AOF112I ACTIVE TYPE= NETOP2
AOF113I DATA IS CLASS=(10)
AOF002I END OF MULTILINE MESSAGE
```

Note: Use of the replace parameter (REPL) adds an entry if none exists, resulting in a successful message.

Generic error messages that can occur:

```
AOF013I SPECIFIED OPERAND operand INVALID FOR PARAMETER parameter.
AOF025I SYNTAX ERROR
```

Examples

The ACF command to display the Start automation flag for the CICST subsystem is:

```
ACF REQ=DISP,ENTRY=START,TYPE=CICST
```

The response is:

```
AOF111I AUTOMATION CONFIGURATION DISPLAY - ENTRY= START
AOF112I ACTIVE TYPE= CICST      , DESIRED TYPE= CICST
AOF113I DATA IS AUTO=Y
AOF113I DATA IS NOAUTO=(TUESDAY,10:00,12:00)
AOF002I END OF MULTILINE MESSAGE
```

In this example, a Start automation flag exists for the CICST subsystem. The operator or automation procedure processes the command to display the entry, and the associated response is returned as a multiline message.

Use the following automation procedure to update ACF data for an entry. It allows you to modify the automation agent configuration data without affecting other automation agents or the automation manager.

```
/* ***** **
** Function: **
** - Read ACF Fragment **
** - Modify ACF entries **
** ***** */
'PIPE (NAME ACFREPL)',
'QSAM (DSN) -dataset-', /* read ACF fragment */
'! NLOC 1.1 /*/', /* skip comments */
'! COLLECT', /* collect to multiline */
'! NETV ACF REQ=REPL', /* call ACF command */
'! CONS' /* issue msgs to console */
```

ACFCMD

Purpose

The ACFCMD routine allows an automation procedure to issue commands defined in the automation policy. It searches the automation control file for the specified entries, performs variable substitution for predefined variables, then issues the commands.

ACFCMD can also issue commands that are built dynamically by the calling automation procedure and passed to ACFCMD through a special task global variable named EHKCMD.

In general you should consider using ISSUEACT or ISSUECMD from the automation table, rather than calling ACFCMD directly. This has the following advantages:

- It will check the automation flags for you, to ensure that automation is allowed.
- It will check that the job that issued the message is known to SA z/OS.

Syntax

To issue commands that are directly defined in the automation control file use the following syntax:

1. Syntax for directly defined commands

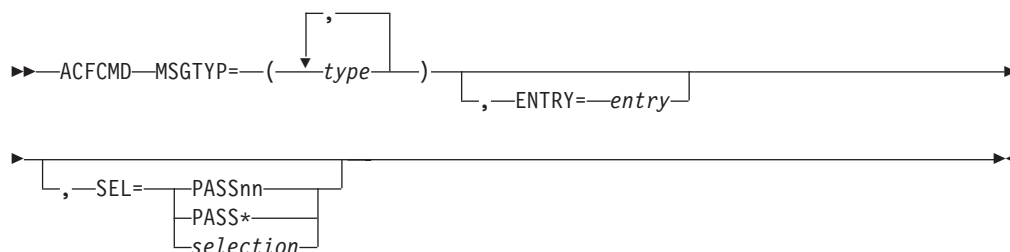

To issue commands built dynamically by the calling automation procedure use the following syntax:

2. Syntax for dynamically built commands



Parameters

MSGTYP=*type*

This value is the message ID in the MESSAGES/USER DATA policy item where the commands to be issued by ACFCMD are defined. The value of MSGTYP is typically coded with the message ID or with a generic name such as SPOOLSHORT or SPOOLFULL. The specified *type* values are searched in the order specified until an entry with the given entry and type value can be found.

ENTRY=*entry*

This value is the entry in the automation MESSAGES/USER DATA policy item where the commands to be issued are defined. The default is the subsystem name, if the commands are issued for applications.

This parameter is mutually exclusive with the FUNC=ISSUE parameter.

SEL=

This parameter provides the criteria for the first field in the command entry. This field gives detailed criteria to select a command or commands from the automation control file. Based on the MSGTYP, ENTRY and SEL fields, any specific command can be retrieved from a group of commands associated with a message entry. This parameter is mutually exclusive with the FUNC=ISSUE parameter.

The commands associated with the specific pass selection value defined in the automation policy are issued, along with all commands defined without a selection value. For selection values beginning with PASS, additionally those commands with the pass selection value of PASS* are issued.

IF no SEL parameter is coded, all commands are selected without respect to any pass selection value in the first field of the command entry.

PASS nn

PASS nn values can range from 1 through 99 and must be coded without leading zeros, such as PASS1, PASS2, and PASS3.

When SEL=PASS nn is specified, commands associated with the PASS nn selection value defined in the automation policy are issued, along with all commands defined with a selection value of PASS* or with no selection value.

PASS*

When SEL=PASS* is specified, commands associated with the PASS* selection value defined in the automation policy are issued, along with all commands defined with a selection value beginning with the prefix PASS or with no selection value.

selection

When SEL=*selection* is specified, the commands associated with the specific selection value defined in the automation policy are issued, along with all commands defined without a selection value.

FUNC=ISSUE

The command to be issued is taken from the task global variable EHKCMD.

This parameter is mutually exclusive with the ENTRY and SEL parameters.

Restrictions and Limitations

This routine should be called by an automation procedure or by a command processor. The common routine AOCQRY must be invoked first to set the task global variables SUBSAPPL and SUBSTYPE.

The ACF COLD command and the ACF WARM command temporarily disable automation. ACFCMD will not work while the automation control file is being reloaded. This is necessary to ensure that the SA z/OS environment, as defined by the reloaded automation control file, is established correctly. Full automation resumes when the AOF540I - INITIALIZATION RELATED PROCESSING HAS BEEN COMPLETED message has been received.

Return Codes

- 0 At least one command was found and issued.
- 1 No commands meeting the selection criteria were found.
- 2 The issued command returned a non-zero return code and return code checking was enabled through the customization dialogs.
- 4 Invalid parameters were used in the call.
- 6 SA z/OS initialization incomplete, unable to process command request.

Usage

- If the command that is issued uses symbols you should call AOCQRY to substitute or translate the symbols. Refer to the tables in “Task Global Variables” on page 44 for AOCQRY.
- ACFCMD can issue multiple commands during a single instance of processing. Commands can be defined to one ENTRY and MSGTYP combination but with different or duplicate selection fields. During processing all selection fields are located that match the selection criteria and their associated commands are issued in the same sequence that they have been defined in the automation policy.
- When FUNC=ISSUE is used this routine can issue only one command during a single instance of processing.
- SA z/OS variable CMDCNTHI is returned to the calling automation procedure as a task global variable value. ACFCMD retrieves all command entries for a given ENTRY/MSGTYP and searches for the highest PASS nn number. The highest PASS nn number is returned in CMDCNTHI. You can use this number to determine whether all available commands are issued and an appropriate error message should be issued to the operator. If PASS nn is not coded, CMDCNTHI is zero.
- Variables are available to change the command entered in the automation control file. Variables &EHKVAR0 through &EHKVAR9 and &EHKVART must be defined as task global variables in the calling automation procedure and must be initialized with the data to change the commands. These variables are passed to ACFCMD. Whenever ACFCMD finds a detail command entry in the automation control file it scans the command entry looking for &EHKVAR n . If an &EHKVAR n variable is found, the value stored in the automation procedure variable replaces the &EHKVAR n in the command entry. Multiple &EHKVAR n variables can be coded in a single command entry. Delimiters are unnecessary, and the variables can be coded between any other text.

Task Global Variables

The following run time variables are used by ACFCMD for different purposes:

CMDCNTHI

This variable contains the number of the highest PASS nn selection for defined commands to the specified entry and type in the automation policy.

EHKCMD

When ACFCMD is called with FUNC=ISSUE, this variable must provide the command that is to be issued.

EHKCMDTEXT

Text for confirmation message AOF570I, after having issued the command.

EHKVAR0 through EHKVAR9 and EHKVART

These variables can be used to alter command definitions in the automation policy. If included in the defined commands with a leading &, the variables are substituted by their values before the commands are issued. The values of these variables must be provided by the calling automation routine.

&APPLPARMS

This variable provides the value that is entered in the APPLPARMS parameter of the INGREQ command when starting or stopping the resource related to the specified entry. The value of this variable is only available during startup or shutdown processing of a resource under the control of SA z/OS and can be used to alter commands entered in the automation policy.

ACFCMD

If the AOCQRY common routine has been invoked in the calling automation routine, it sets the following task global variables if the appropriate information is applicable. These variables can be used to alter commands that are entered in the automation policy:

- SUBPAPPL
- SUBPCMDPFX
- SUBPDESC
- SUBPJOB
- SUBPSHUTDLY
- SUBPSUBID

- SUBSAPPL
- SUBSASID
- SUBSCATEGORY
- SUBSCMDPFX
- SUBSDESC
- SUBSFILE
- SUBSJOB
- SUBSPATH
- SUBSPID
- SUBSPORT
- SUBSPROC
- SUBSSCHEDSS
- SUBSSHUTDLY
- SUBSSPARM
- SUBSSUBCAT
- SUBSSUBID
- SUBSSUBTYPE
- SUBSUSER
- SUBSUSSJOB

These task global variables are substituted when they are found specified with a leading & in commands defined in the automation policy.

Common Global Variables

Common global variable AOFJESPREFIX is substituted in the command to be issued when found.

Examples

Example 1

This example shows the relationship between ACFCMD and the automation control file. The message to automate, \$HASP607, is produced by the JES2 subsystem and indicates that JES2 is not dormant. The automation procedure responds to this by calling ACFCMD to issue a command to stop the JES2 initiators, (MVS \$PI).

The command is defined in the automation policy through the customization dialog panels.

If you enter DISPACF JES2 \$HASP607 a panel with information similar to Figure 1 on page 17 is displayed.

```

Command = ACF ENTRY=JES2,TYPE=$HASP607,REQ=DISP
SYSTEM = KEY3      AUTOMATION CONFIGURATION DISPLAY - ENTRY= JES2
-----
AUTOMATION CONFIGURATION DISPLAY - ENTRY= JES2
TYPE IS $HASP607
CMD      = (,,'MVS $PI')
END OF MULTI-LINE MESSAGE GROUP

```

Figure 1. DISPACF Command Response Panel

The automation procedure to issue this command is:

```

/* REXX CLIST to automate $HASP607                */
/* Check whether automation allowed and set TGLOBALs */
'AOCQRY ...'
:
'ACFCMD MSGTYP=$HASP607,ENTRY=JES2'
Select
  When rc = 0 Then Nop      /* Command issued OK                */
  When rc = 1 Then Do      /* No commands issued; warn if required */
  :
  End
  Otherwise Do              /* Error; perform warning action      */
  :
  End
End
Exit

```

ACFCMD uses the parameters passed to it to find the corresponding values in the automation policy. Because no SEL parameter is coded, no selection restriction is made with respect to the first field of the command entry.

Upon return to the automation procedure, the rc special variable is checked to ensure a command was found in the automation control file. The automation procedure takes appropriate action if a command is not found or a processing error occurs in the ACFCMD routine.

Example 2

This example uses the same scenario as Example 1, but shows how you can use defaults to minimize coding. The message to automate, \$HASP607, is produced by the JES2 subsystem and indicates that JES2 is not dormant. The automation procedure responds by calling ACFCMD to issue a command to stop the JES2 initiators (\$PI).

The command is defined in the automation policy as in Example 1.

The automation procedure to issue this command is:

```

/* REXX CLIST to automate $HASP607                */
/* Check whether automation allowed and set TGLOBALs */
'AOCQRY ...'
:
'ACFCMD MSGTYP='Msgid()'
Select
  When rc = 0 Then Nop      /* Command issued OK                */
  When rc = 1 Then Do      /* No commands issued; warn if required */
  :
  End
  Otherwise Do              /* Error; perform warning action      */
  :
  End
End
Exit

```

This example differs from Example 1 in the following ways:

- ACFCMD uses a NetView REXX function for the MSGTYP field, assumes defaults for the ENTRY and SEL fields and uses task global variables set up by AOCQRY for the ENTRY default.
- The ENTRY field defaults to JES2 because the job name on the message was the job name for the JES2 subsystem, so the SUBSAPPL task global (which is the default entry type) currently contains JES2. Common routine AOCQRY must be called before ACFCMD for the ENTRY default to work correctly.
- The MSGTYP field uses the NetView REXX function Msgid(), which contains the message identifier for the message that called the automation procedure. This message identifier is supplied only to an automation procedure called from the NetView automation table. This value can be used when calling ACFCMD.

Note: If your code issues a WAIT command before it issues the ACFCMD you must store the msgid() value in a temporary global as the NetView MSGREAD command overwrites the data from the message that invoked the procedure.

Assuming that AOCQRY is invoked to check the Terminate flag, both of the above examples are equivalent to invoking the following from the NetView automation table for \$HASP607:

```
ISSUECMD AUTOTYP=TERMINATE
```

Example 3

This example shows the use of *PASS_{*n*}* logic in an automation procedure. The message to automate, \$HASP607, is produced by the JES2 subsystem and indicates that JES2 is not dormant. The automation procedure responds the first time by stopping the JES2 initiators (\$PI command), and the second time by abending JES2 (\$P JES2,ABEND).

The commands are defined in the automation policy through the customization dialogs. The data is stored in the automation control file in the following way:

```
AUTOMATION CONFIGURATION DISPLAY - ENTRY= JES2
TYPE IS $HASP607
CMD          = (PASS1,, 'MVS $PI')
CMD          = (PASS2,, 'MVS $P JES2,ABEND')
END OF MULTI-LINE MESSAGE GROUP
```

The automation procedure to issue the commands is:

```
/* REXX CLIST to automate $HASP607 */
/* Check whether automation allowed and set TGLOBALs */
'AOCQRY ...'
:
/* Increase the counter unique to this automation procedure */
'GLOBALV GETC HASP607_CNT'
If hasp607_cnt = " Then hasp607_cnt = 1
Else hasp607_cnt = hasp607_cnt + 1
'GLOBALV PUTC HASP607_CNT'
/* Issue the ACF command for the pass number as determined */
'ACFCMD MSGTYP='Msgid()',SEL=PASS'hasp607_cnt
Select
  When rc = 0 Then Nop      /* Command issued OK */
  When rc = 1 Then Do      /* No commands issued; warn if required */
  :
  End
  Otherwise Do              /* Error; perform warning action */
```

```

:
End
End
Exit

```

This example differs from the previous examples in the following ways:

- The automation procedure uses a unique common global variable, in this case HASP607_CNT, to maintain a PASS counter. The automation procedure adds 1 to this counter each time it is processed, then appends the counter to the SEL=PASS field. During processing, the counter is translated, and PASS1 or PASS2 is processed. Note that a null test is required to set the counter to 1 if it has not been set before. If the counter exceeds 2 then the ACFCMD will set a return code of 1 since there is no matching entry in the automation control file.

Note: This example assumes you are using one JES subsystem. If you are using multiple JES subsystems, you must use a different counter variable for each.

- Another automation procedure that resets the counter is necessary to complete the logic flow. For this example, the automation procedure runs when the final JES2 message or a startup message is received. Note that the counter is cleared rather than set to zero. This saves an entry in the NetView global dictionary unless the message \$HASP607 has occurred.

The automation procedure to reset the counter is:

```

/* REXX CLIST to reset the counter                               */
hasp607_cnt = ''
'GLOBALV PUTC HASP607_CNT'
Exit

```

Notes:

1. To ensure serialization of access to the NetView global dictionary and the correct ordering of the commands issued, the NetView automation table entry should route the command to a specific operator if the message may occur more than once in quick succession.
2. If AOCQRY is checking the Terminate flag this example could be coded as:
ISSUECMD AUTOTYP=TERMINATE,PASSES=YES

The pass count will be reset when the application final termination message is processed.

Example 4

This example shows the use of EHKVAR n variables. It also shows the use of duplicate selection fields because two entries are coded, each with PASS1. The message to automate is given in response to the JES2 \$DU command, which displays all JES2 devices. The message ID produced by JES2 is \$HASP628. The example assumes the full text of the message is passed to the automation procedure. The automation procedure checks the resource type, and if the resource is a line, stops the line using the \$P LINE nm command, then stops current activity with a restart command, \$E LINE nm .

The commands are defined in the automation policy through the customization dialog panels. The data is stored in the automation control file in the following way:

ACFCMD

```
AUTOMATION CONFIGURATION DISPLAY - ENTRY= JES2
TYPE IS $HASP628
CMD          = (PASS1,, 'MVS $P &EHKVAR1')
CMD          = (PASS1,, 'MVS $E &EHKVAR1')
END OF MULTI-LINE MESSAGE GROUP
```

The automation procedure to issue the commands is:

```
/* REXX CLIST to automate $HASP628 */
/* Check whether automation allowed and set TGLOBALs */
'AOCQRY ...'
:
/* Assign EHKVAR1 to parameter 2 (resource name on $HASP628 msg)
then determine whether the first characters are LINE, if not, exit */
ehkvar1 = Msgvar(2)
If Left(ehkvar1,4) <> 'LINE' Then Exit
'GLOBALV PUTT EHKVAR1'
'ACFCMD MSGTYP='Msgid()',SEL=PASS1'
Select
  When rc = 0 Then Nop      /* Command issued OK */
  When rc = 1 Then Do      /* No commands issued; warn if required */
  :
  End
  Otherwise Do             /* Error; perform warning action */
  :
  End
End
Exit
```

Following are the processing steps the automation procedure performs:

1. The EHKVAR1 variable is assigned the value in the second parameter sent to the automation procedure, which for the \$HASP628 message is the resource type
2. The automation procedure verifies that the resource type is a LINE, then sets the variable to a task global variable and calls ACFCMD
3. Assuming the second parameter is LINE21, two commands are issued from this automation procedure:

```
$P LINE21
$E LINE21.
```

ACFFQRY

Purpose

The ACFFQRY command provides a fast, pipeable means of accessing the SA z/OS automation control file from your automation procedures.

See also the related command “ACF” on page 7.

Syntax

The following syntax diagram shows how to use the ACFFQRY command to query the automation control file.

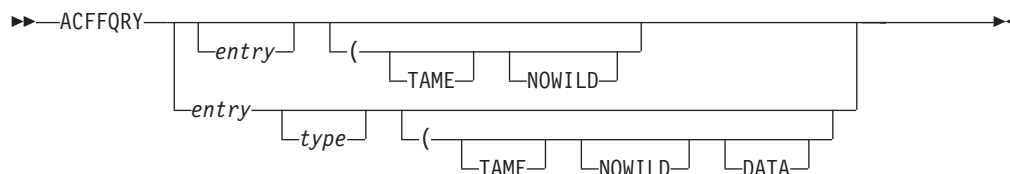

Parameters

entry

This is the *entry* value to be used to search the automation control file. The entry value may take the following forms:

- * The entry value is or ends with the wildcard character, unless TAME is specified.

entry

A specific entry value is entered. You must enter a specific entry value if you want to specify a type value.

type

This is the *type* value to be used to search the automation control file. A type value can be specified *only* when a specific entry value is entered. The type value may take the following forms:

- * The type value is or ends with the wildcard character, unless TAME or NOWILD is specified.

type

A specific type value is entered.

TAME

Wildcards in the entry and type name in the automation control file database are to be matched against the entry and type specified on the search. TAME allows for wildcards IN THE DATABASE you are searching. For example, with a constant query string, such as AAA 123 you can match on multiple entries in the automation control file, such as AAA 12*.

This means that if user entries and types have been set up in the automation control file with an asterisk for the last character they are taming candidates. This may be particularly useful for situations where generic rather than specific data is maintained and used in automation procedures.

NOWILD

The asterisk (*) character in the query string is to be treated as a literal.

DATA

The keyword=value data related to the entry/type pair is to be returned.

Restrictions and Limitations

A type value can be specified only if a specific entry value is specified.

Usage

It is most efficient if it is called within a PIPE, but may also be called within a TRAP/WAIT/MSGREAD.

Task Global Variables

None.

Messages

Output from ACFFQRY takes the form of a correlated multiline message, with one or two list items and data elements on each line of the message. There are no surrounding message IDs or details.

The first line of the multiline message is always the literal ACFFQRY:, followed by the return code from ACFFQRY. If output is present it begins on line two. This means that output returned in a stem must be processed from element two.

If keyword=data is returned, the entry and type will precede it. Your routines can differentiate entry/type output from data output by the presence of an equals (=) sign. For example:

```
If Pos('=' ,data.n) = 0 then Do
/* data line is an ENTRY TYPE */
End
Else Do
/* data line is an KEYWORD=VALUE */
End
```

- If both entry and type parameters are omitted, a list of all the entries is returned.
- If an entry is specified and the type is omitted, a list of the entry and all the types for that entry is returned.
- If both entry and type are specified, all the data for that entry/type combination is returned.
- If the parameters indicate an area where there is no data, a null list is returned.

Table 3 shows the result for various parameter combinations. An “-” means that an option is irrelevant to the output produced. An asterisk in the DATA column indicates that the keyword=value data is returned.

Table 3. Output from ACFFQRY

Entry	Type	TAME	NOWILD	DATA	Result
		-	-		List of all entries
en* or *		No	No		List of entries starting with “en”.
en* or *		Yes	No		List of all entries starting with en or taming en*.
entry		Yes	-	-	List of entries taming entry
entry		No	-	-	List of types for entry
entry	ty*	No	No	*	List of types for entry starting with ty
entry	ty*	Yes	No	*	List of types for entry starting with ty or taming ty*
entry	ty*	No	Yes	*	All data for entry entry and type ty*
entry	ty*	Yes	Yes	*	List of all types for entry taming ty*
entry	type	No	-	-	All data for entry entry and type type
entry	type	Yes	-	*	List of all types for entry taming type

Return Codes

These return codes appear on the first line of the returned data, after the literal ACFFQRY:.

- 0 Data returned.
- 1 There is no data for the specified parameters or SA z/OS is not fully initialized.
- 2 Too many parameters before the opening parentheses. You can specify at most one entry and one type, each of which is a single word.
- 3 Entry/Type combination not allowed. If you have specified an entry including an *, you may not specify a type.
- 5 The SA z/OS global variables containing internal automation control file information have been corrupted.
- 6 You have specified an invalid option.
- 7 You have specified an option more than once.

Examples

Example 1

An ACFFQRY specifying a full ENTRY value only
ACFFQRY SUBSYSTEM

returns all TYPE matches for that ENTRY.

```
ACFFQRY:0
SUBSYSTEM SYSVSSI
SUBSYSTEM SYSVIEW
SUBSYSTEM VLF
SUBSYSTEM LLA
SUBSYSTEM JES
SUBSYSTEM VTAM
SUBSYSTEM TSO
SUBSYSTEM RMF
```

Example 2

An ACFFQRY specifying a full ENTRY value and a full TYPE value
ACFFQRY SUBSYSTEM TSO

returns all keyword=value data that is associated with the ENTRY/TYPE pair.

```
ACFFQRY:0
SUBSYSTEM TSO
JOB=TSO
DESC='Time Sharing Option'
SHUTDLY=00:01:30
```

Example 3

An ACFFQRY specifying a full ENTRY and a wild TYPE
ACFFQRY SUBSYSTEM V*

returns a list of all matching TYPES.

```
ACFFQRY:0
SUBSYSTEM VLF
SUBSYSTEM VTAM
```

Example 4

This example is the same as example 3, except that the DATA option is specified.

```
ACFFQRY SUBSYSTEM V* (DATA
```

The keyword=value data that is values for all matches are returned.

```
ACFFQRY:0
SUBSYSTEM VLF
DESC='Virt Lib DEF'
SCHEDSUB=MSTR
JOBTYPE=MVS
IPOPTIONS=START
RECYCLEOPT=START
RESTARTOPT=ALWAYS
PARMS=' ,SUB=MSTR,NN=00'
SHUTDLY=00:03:00
STRTDLY=00:02:00
TERMDLY=00:00:15
JOB=VLF
SUBSYSTEM VTAM
DESC='VTAM V4.1'
PARMS=' ,,,(LIST=FP)'
SHUTDLY=00:01:00
JOB=VTMN24E
```

Example 5

This example shows the use of the TAME option.

```
ACFFQRY CONTROLLER QLN37A07 (TAME
```

All ENTRY/TYPES that include a wildcard that matches the search string are returned.

```
ACFFQRY:0
CONTROLLER QLN*
CONTROLLER QLN37*
CONTROLLER Q*
```

Example 6

This example is the same as example 5 except that the DATA option is specified.

```
ACFFQRY CONTROLLER QLN37A07 (TAME DATA
```

All keyword=value data for the ENTRY/TYPE list is returned.

```
ACFFQRY:0
CONTROLLER QLN*
LOCATION=NEW_YORK
TYPE=LOCAL
OWNER='FRED SMITH'
CONTROLLER QLN37*
LOCATION='Episode 1, Level 3, Oil Refinery'
TYPE=LOCAL
START='MVS VARY 04AE,ONLINE'
OWNER='JIM SMITH'
CONTROLLER Q*
LOCATION=USA
TYPE=GLOBAL
OWNER='BILL SMITH'
```

Example 7

This example shows the result of the NOWILD option.

```
ACFFQRY CONTROLLER QLN37* (NOWILD
```

The asterisk (*) is treated as a literal in the search pattern.

```

ACFFQRY:0
CONTROLLER QLN37*
LOCATION='Episode 1, Level 3, Oil Refinery'
TYPE=LOCAL
START='MVS VARY 04AE,ONLINE'
OWNER='JIM SMITH'

```

Example 8

The following example shows how to find the job name for a subsystem from a REXX routine, using the NetView PIPE facility.

```

Get_Jobname:
Arg subsystem .
'PIPE NETVIEW ACFFQRY SUBSYSTEM' subsystem '| STEM ALL DATA.',
'| SEPARATE | LOCATE 1.4 /JOB=/ | TAKE 1 | STEM JOBNAME.'
If all_data.0 < 1 Then
  Say 'PIPE 1 Failed'
If all_data.1 <> 'ACFFQRY:0' Then
  Return
If jobname.0 = 0 Then
  Return subsystem
Parse var jobname.1 'JOB=' jobname .
Return jobname

```

Example 9

This example takes the name of a failing device and finds the appropriate person to notify. It makes use of the TAME option. The data being searched is:

```

DEVFAIL DEV1230,
CONTACT=MIK
DEVFAIL DEV12*,
CONTACT=JB
DEVFAIL DEV34*,
CONTACT=JAQUES
DEVFAIL DEV*,
CONTACT=MIK
CONTACT MIK,
page=00230936473
CONTACT JB,
page=00234628164
CONTACT JAQUES,
page=00237564815

```

The code fragment below takes the number of a failing device and returns the paging number for the person to be notified. Note the use of subroutines that make it easy to write similar queries and could replace the previous example.

```

Get_Page_Num:
Procedure
Arg device_number .
match = Get_Best_Match('DEVFAIL',device_number)
If match = '' Then
  Return
contact = Get_Key('CONTACT=', 'DEVFAIL', match)
If contact = '' Then
  Return
Return Get_Key('page=', 'CONTACT', contact)

Get_Best_Match:
Procedure
Arg entry ., type .
'PIPE NETVIEW ACFFQRY' entry type '( TAME | STEM DATA.'
If data.0 < 1 Then
  Say 'Get_Best_Match PIPE Failed'
If data.0 <> 'ACFFQRY:0' Then
  Return
match = '' /* Longest match = best match */

```

ACFFQRY

```
match_len = 0
Do i = 2 to data.0
  If words(data.i) = 2 Then Do
    data_val = word(data.i,2)
    If Length(data_val) > match_len The Do
      match = data_val
      match_len = Length(match)
    End
  End
End
Return match

Get_Key:
Procedure
Arg key . , entry . , type .
'PIPE NETVIEW ACFFQRY' entry type '(NOWILD | STEM ALL_DATA.',
'| SEPARATE | LOCATE 1.' || length(key) '/' || key || '/',
'| TAKE 1 | STEM DATA.'
If all_data.0 < 1 Then
  Call Terminal_Error 'Get_Key PIPE Failed'
If all_data.1 <> 'ACFFQRY:0' Then
  Return
parse var data.1 .=' data_val
Return data_val
```

ACFREP

Purpose

The ACFREP routine allows an automation procedure to issue replies defined in the automation policy. It searches the automation control file for the specified entries, performs variable substitution for predefined variables, then issues the reply.

ACFREP can also issue replies that are built dynamically by the calling automation procedure and passed to ACFREP through a special task global variable named EHKRPY.

ACFREP issues replies to the resource identified by the task global variables SUBSAPPL and SUBSTYPE, which are set by the common routine AOCQRY.

Syntax

To issue replies directly defined in the automation control file use the following syntax:

1. Syntax for directly defined replies

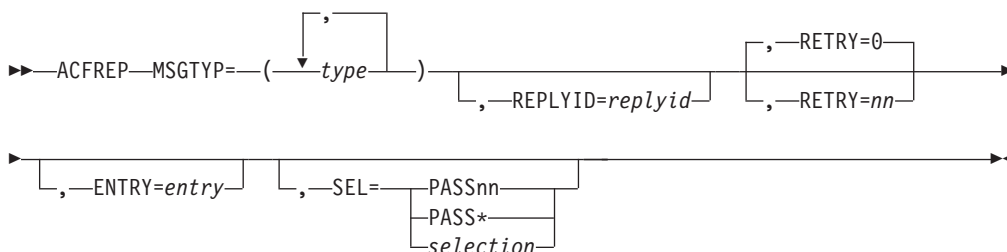

To issue replies built dynamically by the calling automation procedure use the following syntax:

2. Syntax for dynamically built replies

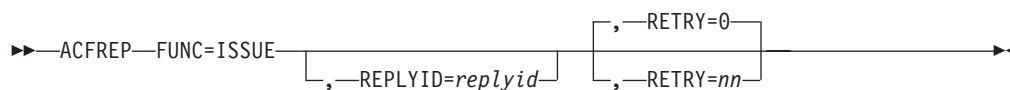

Parameters

MSGTYP

This value is the message ID in the MESSAGES/USER DATA policy item where the replies to be issued by ACFREP are defined. The value of MSGTYP is typically coded with the message ID or with a generic name such as SPOOLSHORT or SPOOLFULL. The specified type values are searched in the order specified until an entry with the given *entry* and *type* value can be found.

REPLYID

The MVS reply identifier associated with this reply.

This parameter is optional. If it is not specified, the outstanding reply value is retrieved and used, regardless of the specified MSGTYP value.

RETRY

nn specifies the retry count if an outstanding reply is not available. The first time after 1 second and then every two seconds, ACFREP attempts to retrieve an outstanding reply until the retry count is exhausted. When an outstanding reply ID is retrieved, the reply is issued. If no RETRY value is coded, ACFREP defaults to RETRY=0.

ENTRY

This value is the entry in the automation MESSAGES/USER DATA policy item where the replies to be issued are defined. The default is the name of the subsystem that issued the WTOR.

This parameter is mutually exclusive with the FUNC=ISSUE parameter.

SEL

This parameter provides the criteria for the first field in the reply entry. This field gives detailed criteria to select a reply or replies from the automation control file. Based on the MSGTYP, ENTRY and SEL fields, any specific reply can be retrieved from a group of replies associated with a message entry. This parameter is mutually exclusive with the FUNC=ISSUE parameter.

The replies associated with the specified pass selection value defined in the automation policy are issued, along with all replies defined without a selection value. For selection values beginning with PASS, those replies to the pass selection value of PASS* are additionally issued.

If no SEL parameter is coded all replies are selected without respect to any pass selection value in the first field of the reply entry.

PASS nn

PASS nn values can range from 1 through 99 and must be coded without leading zeros, such as PASS1, PASS2, and PASS3.

When SEL=PASS nn is specified, replies associated with the PASS nn selection value defined in the automation policy are issued, along with all replies defined with the selection value of PASS* or with no selection value.

PASS*

When SEL=PASS* is specified, replies associated with the PASS* selection value defined in the automation policy are issued, along with all replies defined without a selection value and all replies defined with a selection value beginning with the prefix PASS.

selection

When SEL=*selection* is specified, the replies associated with the specific selection value defined in the automation policy are issued, along with all replies defined without a selection value.

FUNC=ISSUE

The reply to be issued in response to the incoming WTOR is taken from the task global variable EHKRPY.

This parameter is mutually exclusive with the ENTRY and SEL parameters.

Restrictions and Limitations

This routine should be called only by an automation procedure or by a command processor. The common routine AOCQRY must be invoked first to set the task global variables SUBSAPPL and SUBSTYPE.

For serialization reasons, ACFREP must run on:

- The work operator of the subsystem that issued the WTOR if no REPLYID was specified
- The SYSOPER task, if the WTOR was not issued by a subsystem known to SA z/OS

Return Codes

- 0 A reply was found and issued.
- 1 No reply meeting the selection criteria was found.
- 2 No outstanding reply ID was found.
- 3 ACFREP successfully responded to only part of the defined replies.
- 4 Incorrect parameters were used in the call.
- 5 Timeout or other error occurred.
- 6 SA z/OS initialization incomplete, unable to process command request.

Usage

- Consider using ISSUEACT or ISSUEREP from the NetView automation table rather than using ACFREP directly.
- Multiple replies may exist for a given ENTRY, MSGTYP, or SEL field. These replies are processed in the same sequence as they are defined. For the second and subsequent replies, ACFREP always retrieves the outstanding reply number of a subsystem before issuing the reply. If an outstanding reply number does not exist when the reply should be issued, ACFREP attempts a retry if so defined. Retries may be defined either through the RETRY keyword of ACFREP or through the retry value specified in the policy entry. The retry value that you

specified in the RETRY keyword takes precedence over that in your policy if both are specified. There is a 2-second delay between retry attempts.

- SA z/OS variable EHKRPYHI is returned to the calling automation procedure as a task global variable value. ACFREP retrieves all reply entries for a given ENTRY or MSGTYP value, searches for the highest PASS nn number, and returns it in the variable EHKRPYHI. You can use this number to determine whether all available commands are issued and an appropriate error message is issued to the operator. If PASS nn is not coded, EHKRPYHI is zero.
- Variables are available to change the reply entered in the automation control file. Variables EHKVAR0 through EHKVAR9 and EHKVART must be defined as task global variables in the calling automation procedure and must be initialized with the data to change the replies. These variables are passed to the ACFREP routine. Whenever ACFREP finds a detail reply entry in the automation control file, it scans the reply entry looking for &EHKVAR n . If an EHKVAR n variable is found, the value stored in the variable replaces the &EHKVAR n in the reply entry. You can code multiple &EHKVAR n variables in a single reply entry. Delimiters are unnecessary, and you can code the variables between any other text.
- If your automation procedure issues a TRAP command, you must save the message variables upon entry, because this information is lost whenever message processing is started.

Task Global Variables

The following run time variables are used by ACFREP for different purposes:

EHKRPY

When ACFREP is called with FUNC=ISSUE, this variable must provide the reply that is to be issued.

EHKRPYHI

This variable contains the number of the highest PASS nn selection for defined replies to the specified entry and type in the automation policy.

EHKRPYTEXT

The text for the AOF570I confirmation message, after having issued the reply.

EHKVAR0 through EHKVAR9 and EHKVART

These variables can be used to alter reply definitions in the automation policy. If included in the defined replies with a leading &, the variables are substituted by their values before the replies are issued. The values of these variables must be provided by the calling automation routine.

&APPLPARMS

This variable provides the value that is entered in the APPLPARMS parameter of the INGREQ command when starting or stopping the resource related to the specified entry. The value of this variable is only available during startup or shutdown processing of a resource under the control of SA z/OS and can be used to alter replies entered in the automation policy.

If the AOCQRY common routine has been invoked in the calling automation routine, it sets the following task global variables if the appropriate information is available:

- SUBPAPPL
- SUBPCMDPFX
- SUBPDESC
- SUBPJOB
- SUBPSHUTDLY

ACFREP

- SUBPSUBID
- SUBSAPPL
- SUBSASID
- SUBSCATEGORY
- SUBSCMDPFX
- SUBSDESC
- SUBSFILE
- SUBSJOB
- SUBSPATH
- SUBSPID
- SUBSPORT
- SUBSPROC
- SUBSSCHEDSS
- SUBSSHUTDLY
- SUBSSPARM
- SUBSSUBCAT
- SUBSSUBID
- SUBSSUBTYPE
- SUBSUSER
- SUBSUSSJOB

These task global variables are substituted when they are specified with a leading & in replies that are defined in the automation policy or provided in task global variable EHKRPY. Refer to the tables in “Task Global Variables” on page 44 for AOCQRY.

Common Global Variables

Common global variable AOFJESPREFIX is substituted in the reply to be issued when found.

Examples

Example 1

This example shows the relationship between ACFREP and automation policy. The message to automate, \$HASP426, is produced by the JES2 subsystem, requesting the JES2 startup specifications. The automation procedure responds to this by calling ACFREP to issue a reply of WARM,NOREQ from the automation control file.

The data is stored in the automation control file in the following way:

```
AOFK3D0X          SA z/OS - Command Response      Line 1    of 4
Domain ID   = IPSNO   ----- DISPACF -----   Date = 06/06/00
Operator ID = NETOP1                                Time = 13:30:53

Command = ACF ENTRY=JES2,TYPE=$HASP426,REQ=DISP
SYSTEM = KEY3      AUTOMATION CONFIGURATION DISPLAY - ENTRY= JES2
-----
AUTOMATION CONFIGURATION DISPLAY - ENTRY= JES2
TYPE IS $HASP426
REPLY      = (, 'WARM,NOREQ')
END OF MULTI-LINE MESSAGE GROUP
```

The automation procedure to issue this reply is:

```
/* REXX CLIST to automate the reply to $HASP426          */
/* Check whether automation allowed and set TGLOBALs     */
'AOCQRY ...'
:
```



```
'ACFREP MSGTYP=$HASP426,REPLYID='Replyid()',ENTRY=JES2'
Select
  When rc = 0 Then Nop      /* Reply issued OK          */
  When rc = 1 Then Do      /* No reply issued; warn if required */
  :
  End
  Otherwise Do              /* Error; perform warning action    */
  :
  End
End
Exit
```

ACFREP uses the parameters that are passed to the routine to find corresponding entries in the automation control file. Because no SEL parameter is coded, no selection restriction is made concerning the first field of the command entry.

Note that the function Replyid() is used for the REPLYID parameter. This function is a standard NetView REXX function that will only return a value to an automation procedure called from the NetView automation table, and only if a reply is required. You can use this value when calling ACFREP.

Upon return to the automation procedure, the rc special variable is checked to ensure that a reply was found in the automation control file. The automation procedure takes appropriate action if a reply is not found or a processing error occurs in ACFREP.

Note: Assuming that AOCQRY was checking the Start automation flag, this example routine could be replaced by coding:

```
ISSUEREP AUTOTYP=START
```

Example 2

This example uses the same scenario as Example 1, but shows how you can use the defaults to minimize coding. The message to automate, \$HASP426, is produced by the JES2 subsystem and requests the JES2 startup specifications. The automation procedure responds to this by calling ACFREP to issue a reply of WARM,NOREQ from the automation control file.

The reply is defined in the automation policy in the same way as Example 1.

The automation procedure to issue the reply is:

```
/* REXX CLIST to automate the reply to $HASP426          */
/* Check whether automation allowed and set TGLOBALs     */
'AOCQRY ...'
:
'ACFREP MSGTYP='Msgid()',REPLYID='Replyid()'
Select
  When rc = 0 Then Nop      /* Reply issued OK          */
  When rc = 1 Then Do      /* No reply issued; warn if required */
  :
  End
  Otherwise Do              /* Error; perform warning action    */
  :
  End
End
Exit
```

This example differs from Example 1 in the following ways:

- ACFREP uses a NetView REXX function for the MSGTYP field and assumes the defaults for the ENTRY and SEL fields.

The ENTRY field defaults to the value of SUBSAPPL. AOCQRY will set this value to the name of the application that AOCQRY was invoked with. In this case the value is JES2.

- The MSGTYP field uses the NetView REXX function Msgid(), which contains the message identifier for the message that called the automation procedure. This message identifier is supplied only to an automation procedure called from the NetView automation table. Use this value when calling ACFREP. Note that calling WAIT will replace the value of Msgid().

Note: Assuming AOCQRY was checking the Start flag, this example could be replaced with:

```
ISSUEREP AUTOTYP=START
```

Example 3

This example shows the use of *PASS_n* logic in an automation procedure. The message to automate, \$HASP098, is produced by the JES2 subsystem and requests the JES2 shutdown options. The automation procedure responds to this, the first Reply time, by calling ACFREP to issue a REPLY of DUMP from the automation control file, and the second time by issuing a reply of PURG.

Reply information is defined in the automation policy through the customization dialogs. The data is stored in the automation control file in the following way:

```
AOFK3D0X          SA z/OS - Command Response          Line 1    of 5
Domain ID   = IPSNO   ----- DISPACF -----      Date = 06/06/00
Operator ID = AFRANCK                                     Time = 13:36:31

Command = ACF ENTRY=JES2,TYPE=$HASP098,REQ=DISP
SYSTEM = KEY3      AUTOMATION CONFIGURATION DISPLAY - ENTRY= JES2
-----
AUTOMATION CONFIGURATION DISPLAY - ENTRY= JES2
TYPE IS $HASP098
REPLY      = (PASS1,, 'DUMP')
REPLY      = (PASS2,, 'PURG')
END OF MULTI-LINE MESSAGE GROUP
```

The automation procedure to issue these replies is:

```
/* REXX CLIST to automate $HASP098                               */
/* Check whether automation allowed and set TGLOBALs           */
'AOCQRY ...'                                                    */
:
/* Increase the counter unique to this automation procedure     */
'GLOBALV GETC HASP098_CNT'                                       */
If hasp098_cnt = " Then hasp098_cnt = 1
Else hasp098_cnt = hasp098_cnt + 1
'GLOBALV PUTC HASP098_CNT'
/* Issue the ACF reply for the pass number as determined       */
'ACFREP MSGTYP=Msgid(),REPLYID=Replyid(),SEL=PASS'hasp098_cnt */
Select
  When rc = 0 Then Nop      /* Reply issued OK                               */
  When rc = 1 Then Do      /* No reply issued; warn if required                       */
  :
  End
  Otherwise Do              /* Error; perform warning action                           */
  :
  End
End
Exit
```

This example differs from the previous examples in the following ways:

- The automation procedure uses a unique common global variable, in this case HASP098_CNT, to maintain a PASS counter. The automation procedure adds 1 to this counter each time it is processed, then appends the counter to the SEL=PASS field. During processing, the counter is translated, and PASS1 or PASS2 is run. Note that a null test is required to set the counter to 1 if it has not been set before. If the counter exceeds 2 then the ACFREP will set a return code of 1 since there is no matching entry in the automation control file.
- Another automation procedure that resets the counter is necessary to complete the logic flow. In this example, this automation procedure is processed when the final JES2 message or a startup message is received.

The automation procedure to reset the counter is:

```
/* REXX CLIST to reset the counter                               */
hasp098_cnt = ''
'GLOBALV PUTC HASP098_CNT'
Exit
```

Note: To ensure serialization of access to the NetView global dictionary and the correct ordering of the replies issued, the NetView automation table entry should route the command to a specific operator if the message may occur more than once in quick succession.

AOCGETCN

Purpose

The AOCGETCN command obtains an extended MCS console with a unique name for an operator or autotask issuing the command. If an MVS console is already associated with that task, it is released.

The default console name is the character A, followed by the last 5 characters of the task name concatenated with the last two characters of the system name.

Syntax

►►—AOCGETCN—*parameters*—◄◄

Parameters

Optionally, you may supply one or more parameters that are valid for NetView's GETCONID, for example, ALERTPCT, MIGRATE, QLIMIT, QRESUME, or STORAGE.

If you specify more than one parameter, you can either separate them by blank or by comma, for example:

```
AOCGETCN MIGRATE=YES,STORAGE=1000
```

For further information and a list of valid GETCONID parameters and their descriptions, refer to the NetView documentation.

Restrictions and Limitations

The previous console will be released even if AOCGETCN fails to obtain the new console.

AOCGETCN

The GETCONID parameters `CONSOLE=xxxxxxx` and `AUTH=yyyyyy` are not supported. If you enter them, they will be ignored.

Usage

Console names within a sysplex must be unique. The task name is used if the console name is not specified. To avoid possible naming conflicts due to common task names AOCGETCN should be used to obtain a console with a unique name. The characters that are used in determining the unique console name can be tailored by updating the common global variable AOFCNMASK. Refer to *IBM Tivoli System Automation for z/OS Customizing and Programming* for further information.

Example

Issue AOCGETCN, for example, in the initial clist of an operator or autotask. As soon as an MVS command is issued by the task, a console is allocated with the console name that has been set by AOCGETCN.

AOCMSG

Purpose

AOCMSG displays and logs messages. AOCMSG merges variable data specified as parameter values in the AOCMSG call with fixed message text to produce an SA z/OS message. You can display the resulting message on a NetView console and log it in the NetView log.

The message format depends on the message ID and variable data placed in the message.

If you specify one or more message classes in the message, AOCMSG also performs message class matching and sends the message as a notification message to one or more notification operators defined to receive those classes of notification messages.

AOCMSG uses the NetView message handling facilities, specifically NetView macros DSIMDS and DSIMBS. When you want to define user messages you must code a message definition module named AOFMaaa where aaa is the message prefix. Refer to *NetView Customization: Using Assembler* for the coding. Examples 1 and 2 in this section require a message definition module of AOFMABC.

The parsing within AOFMSG has been rewritten with an SA z/OS parsing routine used instead of DSIPRS. This allows SA z/OS to be more flexible in the handling of parameters. The parsing rules are:

- The only delimiter recognized in parsing the command is the comma.
- Tokens surrounded by single quotes will be stored without the quotes.
- A token containing two consecutive single quotes will be stored with only one of the quotes.
- Leading and trailing spaces are removed except that spaces inside quotes are not removed.
- Instead of rejecting a command with mismatched quotes an attempt is made to break the command into tokens.

The rules are illustrated by the following examples:

COMMAND	TOKENS
A,BCDEF, G	(A) (BCDEF) (G)
'A B C' , ' EF GH'	(A B C) (EF GH)
ABC,,DEF	(ABC) () (DEF)
'ABC,DEF,GHI	(ABC,DEF,GHI)
'ABC''DEF'	(ABC'DEF)
'ABC,DEF	('ABC) (DEF)
ABC'DEF	(ABC'DEF)
ABC'DEF'	(ABC'DEF')
'ABC'DEF	(ABC) (DEF)
'ABC'DEF'	(ABC) (DEF')
'ABC''DEF	(ABC) ('DEF)
ABC''	(ABC')

Note: AOCMSG has the facility to use MVS descriptor codes to control the message flow at the master console. Refer to *IBM Tivoli System Automation for z/OS Messages and Codes* for a table of message types and descriptor codes used by AOCMSG.

Syntax

Parameters are positional.

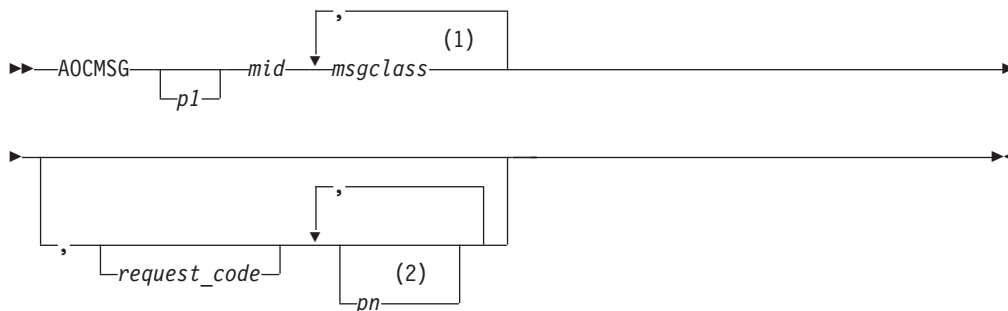

Notes:

- Up to 10 optional message classes can be specified with the *mid* parameter. If used, message classes should be separated from the *mid* value and each other by at least **one** blank.
- Parameters 2 to 9 may be specified here. Parameters are positional, so non-specified parameters must be represented by a comma.

Parameters

p1...p9

These are parameter values that are substituted into the message text (located in a NetView DSIMSG member) in place of NetView message variables &1 through &9, respectively. These parameter values are all optional. However, because parameters are positional, if you do not specify *p1*, you must code a comma for that parameter position, for example:

```
aocmsg ,abc123,,date(),time()
```

mid

The message ID to be issued. This parameter is required. The message ID must

be a valid message installed in the NetView message library, that is, in data set members identified in DSIMSG. The message ID can be specified in the following ways:

- A 3-digit number, which is assumed to have a prefix of AOF.
This message ID value relates to a message in DSIMSG member DSIAOF*nn*. For example, a message ID value of 203 is for SA z/OS message AOF203I, which is in DSIMSG member DSIAOF20.
- A 6-digit ID consisting of a 3-character prefix followed by a 3-digit message ID number. The first character of the prefix must be alphabetic.
This message ID value relates to a message in DSIMSG member DSI*xxxnn*, where *xxx* is the prefix value and *nn* is the first two digits of the message ID number. For example, a message ID value of ABC123 is for message ABC123I, which is in DSIMSG member DSIABC12.
- A 7-character ID consisting of a 4-character prefix followed by a 3-digit message ID number. The first character of the prefix must be alphabetic.
The primary use for this type of message ID format is when coding a message ID for a message that has a 4-digit prefix.
When this type of message ID value is specified, AOCMSG drops the third of the four prefix characters to create the string used for searching DSIMSG members and retrieving the desired message. The actual message issued uses all four prefix characters.
For example, a message ID value of ABCD123 is used to retrieve message ABCD123I, which is in DSIMSG member DSIABD12 (note that the C is dropped in the DSIABD12 member name).

The message ID value can be up to 7 characters long.

Up to 10 optional dynamic message classes can be specified through the mid field. If specified, optional message classes will be merged with the message classes defined in the message member (if there are any) up to a maximum of 10 message classes. If the total number of message classes exceeds 10, those specified on the AOCMSG call will take precedence over those specified in the message member.

The rules for dynamic message classes are the same as for those defined in the message member.

Message classes specified on the AOCMSG call will be taken into consideration for the following request_codes:

blank
LOG
MIM

When NOMID is used, any message classes specified on the AOCMSG call will be ignored. However, any message classes defined in the message member will continue to appear in the resulting message text.

request_code

This parameter specifies the type of message processing request the AOCMSG common routine performs. The value for this parameter can be one of the following:

Value	Description
-------	-------------

blank

If you leave this parameter position blank, or enter any text other than the values listed below, AOCMSG will generate the message for display. This is the default.

LOG

AOCMSG generates the message and logs the message in the NetView log instead of displaying it on the issuer's console.

MIM (Message in Message)

AOCMSG generates the message and strips the message ID value (*mid*) from the generated message, leaving only the message text. The first word in the message is treated as a valid message ID value (*mid*), and processing continues as if that word were the original *mid*. That is, AOCMSG performs message class matching and notification. See the AOCMSG examples for an example of how this parameter value affects the issued message.

NOMID (No Message ID)

AOCMSG generates the message and strips the message ID value (*mid*) from the generated message, leaving only the message text. AOCMSG does not perform message class matching and notification. See the AOCMSG examples for an example of how this parameter value affects the issued message.

Note: With the exception of the NOMID *request_code* value, forwarding of notification messages to notification operators occurs regardless of the value specified for this parameter.

Restrictions and Limitations

Each variable parameter value besides the message ID value (*mid*) can be up to 80 characters long, but the total maximum message length is 213 characters.

An operator can call this routine from an automation procedure or command processor, or issue it directly from a display station.

Return Codes

0 AOCMSG processed normally.

>0 and <60

An error occurred while processing the NetView DSIPSS macro. The return code is actually from DSIPSS.

60 An error occurred while processing the NetView DSIGET macro to request storage. No storage space is available.

>60

An error occurred while processing the NetView DSIPRS macro.

Note: If you receive return codes other than 0 and 60, refer to *NetView Customization: Using Assembler* for information on resolving the NetView macro problems.

Error messages returned by AOCMSG are:

AOF262E MESSAGE ID mid INVALID, MUST BE "NNN", "ABCNNN", OR "ABCDNNN".

AOF263I MESSAGE ID NUMERIC "nnn" IS NOT NUMERIC.

AOCMSG

AOF264I TOO FEW PARAMETERS ON AOCMSG COMMAND, 2 IS MINIMUM.

abc000I USER MESSAGE mid ISSUED BUT DOES NOT EXIST IN MESSAGE TABLE
DSIabcnn - CALL IGNORED.

Note: In message *abc000I*, the *abc* represents the product identifier portion of the message ID.

Usage

- Parameter values passed to AOCMSG depend on the format of the message entry as coded in the DSIMSG member *DSIxxxxm*.
- AOCMSG uses NetView message handling facilities, DSIMDS and DSIMBS in particular. Refer to *NetView Customization* for details about using DSIMDS to create your own messages.
- AOCMSG implements the SA z/OS notification message function to allow you to forward messages to notification operators. This aspect of AOCMSG processing can be useful if you develop new messages and want notification operators to receive them.

The notification message function is implemented by assigning message classes to your messages. Message classes are assigned within the text of the messages in the DSIMSG member (*DSIxxxxm*). In the text for the message, specify the class or classes (up to five) after the message ID number and before the message text. For example, the following entry for a message assigns message classes 10 and 40 to the message. The message will be issued as a notification message to any notification operators defined to receive class 10 or 40 messages.

```
123I 10 40 THE EAGLE HAS &1
```

Examples

Example 1

Entries for messages in DSIMSG member DSIABC12 are as follows:

```
*****  
120I ...  
121I ...  
122I &1 &2 ON THE &3  
123I 10 40 THE EAGLE HAS &1  
124I ...  
*****
```

An automation procedure contains the following AOCMSG calls referencing messages ABC122 and ABC123.

```
<other automation procedure code>  
:  
AOCMSG HELP,ABC122,,IS,WAY  
AOCMSG LANDED,ABC123  
:  
<other automation procedure code>
```

When AOCMSG is called as specified in the automation procedure, DSIMSG member DSIABC12 is searched for messages ABC122I and ABC123I. Variable substitution for the variables in the message entries occurs, resulting in the following messages being generated:

```
ABC122I HELP IS ON THE WAY  
ABC123I THE EAGLE HAS LANDED
```

Note: Because the DSIMSG member entry for ABC122I does not specify message class information, only the issuer of the automation procedure receives the message, not any notification operators. Because the DSIMSG member entry for message ABC123I specifies message classes 10 and 40, notification operators defined to receive message classes 10 and 40 also receive message ABC123I.

Example 2

Use of the AOCMSG *request_code* parameter value NOMID has the following effect on the messages generated.

The same entries in DSIMSG member DSIABC12 are used.

The AOCMSG calls using the NOMID *request_code* parameter value are as follows:

```
<other automation procedure code>
:
AOCMSG HELP,ABC122,NOMID,IS,WAY
AOCMSG LANDED,ABC123,NOMID
:
<other automation procedure code>
```

These calls and the DSIABC12 entries result in the following messages:

```
HELP IS ON THE WAY
10 40 THE EAGLE HAS LANDED
```

Note: Note that in message ABC123I, the message classes 10 and 40 have not been processed as message classes and appear in the message text. No notification operators receive either message. This is an error for message ABC123. The message is not implemented to use the NOMID parameter value effectively.

Use of the AOCMSG *request_code* parameter value MIM has the following effect on the messages generated.

The same entries in DSIMSG member DSIABC12 are used.

The AOCMSG calls using the MIM *request_code* are as follows:

```
<other automation procedure code>
:
AOCMSG HELP,ABC122,MIM,IS,WAY
AOCMSG 'HELP 40',ABC122,MIM,IS,WAY
AOCMSG LANDED,ABC123,MIM
:
<other automation procedure code>
```

These calls and the DSIABC12 entries result in the following three messages:

HELP IS ON THE WAY

The text HELP is considered to be the new message ID. Because no message classes are in the AOCMSG call, no notification operators receive the message.

HELP IS ON THE WAY

In this case, the value 40 is processed as a message class. This processing causes notification operators defined to receive class 40 messages to also receive this message.

10 THE EAGLE HAS LANDED

The value 40 is processed as a message class, as in previous AOCMSG

examples. In contrast, the value 10 is processed as the message ID, not a message class. Message ABC123 is not implemented to effectively use the MIM parameter value.

AOCQRES

Purpose

The AOCQRES routine examines and returns information about where a resource resides in a sysplex. Optionally, AOCQRES also tries to obtain status information on resources.

Syntax

```
▶▶ AOCQRES subsystem_name [(-STATUS)] ▶▶
```

* (under *subsystem_name*)

Parameters

subsystem_name

Specifies the name of the subsystem.

- * This causes the command to return information about all subsystems within the sysplex.

STATUS

If you specify STATUS, another column will be added to the output. This column contains the current automation status of each subsystem.

Return Codes

- 0 The AOCQRES command completed successfully.
- 1 An error occurred while processing the AOCQRES command. See the accompanying message for the cause of the error.
- 2 The specified subsystem is either unknown or currently not registered.

Usage

The command is to be used within a NetView PIPE statement.

Examples

When you issue the command:

```
PIPE NETV AOCQRES TSO (STATUS | STEM ABC.
```

within a REXX procedure and the system where this command is issued is in a sysplex with four systems, the stem variable ABC. will be assigned something similar to the following:

```
ABC.0 = 4
ABC.1 = TSO      TSO      KEY3      UP
ABC.2 = TSO      TSO      KEY4      AUTODOWN
ABC.3 = TSO      TSO      KEY5      STARTED
ABC.4 = TSO      TSO      KEY6      RESTART
```

The first token of the data is the subsystem name, the second token is the subsystem's job name, the third token is the system name and the last token is the subsystem's status.

AOCQRY

Purpose

The AOCQRY routine verifies that automation is allowed for a specific resource. AOCQRY does the following:

- Searches the automation policy to verify that the resource is defined to SA z/OS.
- Checks that the automation flags for that resource allow automation
- Initializes certain control variables for use by the calling automation procedure
- Drives automation flag exits
- Initializes AOCQRY task global variables with application information

A call to AOCQRY is intended to be a standard component of most automation procedures. AOCQRY should be called whenever resource automation is required to verify whether automation should continue.

AOCQRY only works for applications that have been defined to automation using the application policy object of the customization dialogs.

Syntax

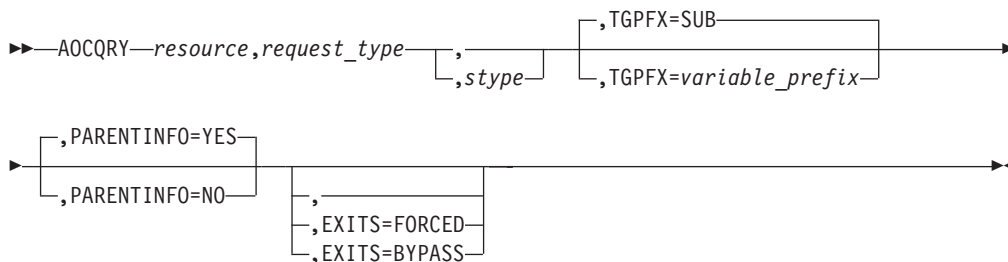

Parameters

resource

The resource name that automation should be checked for. This value can be a:

- Job name
- Subsystem name
- Subsystem minor resource, such as CICS.TRAN.APPL1, where the first qualifier can be the job name of the subsystem
- MVS component minor resource, such as MVSESA.SMF
- SUBSYSTEM
- DEFAULTS

If *stype* is coded, the resource is assumed to be a minor resource and, if the specified resource name does not already begin with the value of *stype*, it is prefixed with the value of *stype*, separated by a period.

If *stype* does not specify the name of a subsystem or MVSESA (the value of the AOFSYSTEM common global variable), the resource name is prefixed with

MVSESA. When, for example, calling AOCQRY SMF RECOVERY MVSESA or AOCQRY MVSESA.SMF RECOVERY MVSESA, MVSESA.SMF is assumed as the resource name in both cases.

This parameter is required.

request_type

The type of automation checks and information retrieval functions AOCQRY performs. *request_type* is required and must be one of the following:

AUTOMATION

Only the Automation flag is checked to determine whether automation is allowed. Data retrieval from the automation policy occurs as described for the CFGINFO option. If the *stype* parameter is coded data retrieval does not occur.

INITSTART

The Automation flag and the Initstart flag are checked in determining whether automation is allowed. Data retrieval from the automation policy occurs as described for the CFGINFO option. If the *stype* parameter is coded data retrieval does not occur.

START

The Automation flag and the Start flag are checked in determining whether automation is allowed. Data retrieval from the automation policy occurs as described for the CFGINFO option. If the *stype* parameter is coded data retrieval does not occur.

RECOVERY

The Automation flag and the Recovery flag are checked in determining whether automation is allowed. Data retrieval from the automation policy occurs as described for the CFGINFO option. If the *stype* parameter is coded data retrieval does not occur.

TERMINATE

The Automation flag and Terminate flag are checked in determining whether automation is allowed. Data retrieval from the automation policy occurs as described for the CFGINFO option. If the *stype* parameter is coded data retrieval does not occur.

RESTART

The Automation flag and the Restart flag are checked in determining whether automation is allowed. Data retrieval from the automation policy occurs as described for the CFGINFO option. If the *stype* parameter is coded data retrieval does not occur.

CFGINFO or STATUS

Selected information about the specified resource is retrieved from the automation policy and provided in predefined task global variables. Regardless of whether the resource is a subsystem name or a minor resource to a subsystem, information retrieval is performed for the subsystem and its parent. This parameter is mutually exclusive with the *stype* parameter and is not supported for the specified resources DEFAULTS, SUBSYSTEM or MVSESA (the value of the AOFSYSTEM common global variable) and its minor resources. Supported task global variables are documented in "Task Global Variables" on page 44.

CFGONLY or CFG-ONLY or STATUS-ONLY

Selected information is provided as described for the CFGINFO option, but without information to the subsystem parent.

stype

If *stype* is coded, the specified resource parameter is assumed to be a minor resource and, if the specified resource name does not already begin with the value of *stype*, it is prefixed with the value of *stype*, separated by a period.

The *stype* values SUBSYSTEM and DEFAULTS are silently ignored.

This parameter is mutually exclusive with the resource values DEFAULTS and SUBSYSTEM and with the *request_type* values CFGINFO, CFGONLY, CFG-ONLY, STATUS and STATUS-ONLY. Data retrieval does not occur for any other combination of the *request_type* and *stype* parameters.

TGPFX=variable_prefix

Specifies the variable prefix that is used to create the names of the task global variables that AOCQRY provides the retrieved information in.

The value of *variable_prefix* must be 3 characters long and defaults to SUB.

If you call AOCQRY from a routine that is driven from the automation control file you must specify a variable prefix for TGPFX= that is something other than SUB or you will corrupt the task global variables that are used by the routine that is driving your routine. This can lead to unpredictable behavior.

PARENTINFO

Specifies whether information about the parent of the resource is retrieved and provided in task global variables.

The following values can be specified:

YES

Parent information is retrieved and provided in task global variables. If the dependency has a sequence number, PARENTINFO defaults to YES. Otherwise, PARENTINFO=NO applies.

Note: If the subsystem has multiple dependencies with sequence numbering, information is obtained for the resource with sequence number one only. If information is required for all the supporting resources, AOCQRY must be issued for each of them. A list of the supporting resources can be obtained from the SUBSPARENT task global variable.

NO

Parent information is not obtained.

This value is enforced for *request_type* values CFGONLY, CFG-ONLY and STATUS-ONLY.

EXITS

This parameter determines how automation flag exits are invoked. The following values can be specified:

FORCED

When FORCED is specified, automation flag exits are invoked during flag evaluation regardless of the automation flag setting.

BYPASS

When BYPASS is specified, defined exits to an automation flag of a resource are executed, when this automation flag is checked during flag evaluation and when the flag value is E.

This is the default value.

Restrictions and Limitations

AOCQRY does not clear its task global variables before resetting them. Thus these task global variable may contain data from an earlier AOCQRY call that was for a different subsystem.

Return Codes

- 0 Function completed successfully. If checking an automation flag, automation is allowed.
- 1 Global Automation flag is off.
- 2 The specific automation flag is turned off.
- 3 A valid application entry was not found in the automation control file. Not used if the *stype* parameter is coded.
- 4 Incorrect parameters were used in the call.
- 6 SA z/OS initialization incomplete, unable to process command request.

Note: If AOCQRY processes with a return code greater than 2, no task global variables are updated.

Usage

- AOCQRY accesses the automation flag settings as they are defined via the customization dialog or dynamically changed via the INGAUTO command to determine whether automation should continue.
- Return codes 1 and 2, which specify that automation is turned off, are set when automation flags are set to NO or are disabled for a certain time.
- Return code 3 indicates that this application is not defined to SA z/OS and therefore no automation should be done for it.
- The AOCQRY routine searches through the automation flags in a predefined sequence to decide whether automation should continue. The first Automation flag entry defined in the automation policy governs whether automation is allowed. The search order is:
 1. The flags associated with the fully-qualified resource name as derived from the input parameters.
 2. If the resource name consists of several qualifiers, the flags associated with the resource name, which has been truncated by one qualifier.
 3. If the last remaining resource qualifier is the name of a subsystem, the flags associated with SUBSYSTEM.
 4. The flags associated with DEFAULTS.
- If the *request_type* is coded as Initstart, Start, Recovery, Terminate or Restart, a two-level search is performed. The predefined search sequence described above is performed twice: first for the Automation flag, and then for the specific automation flag. If the Automation flag turns off automation, the second search is not performed and AOCQRY processing terminates.

Task Global Variables

There are three main groups of task global variables that are provided by AOCQRY:

- Application information task global variables (SUBSxxxxx)
- Parent information task global variables (SUBPxxxxx)

- Automation flag task global variables

If *stype* is not coded in the AOCQRY call, the following apply:

- All task global variables are modified unless parent information is not requested or parent information is not valid.
- If an application entry is not found, the task global variables are not altered from previous settings.

If *stype* is coded in the AOCQRY call, only SUBSAPPL, SUBSTYPE and AUTOTYPE are modified. All other task global variables retain their previous value.

Table 4 lists AOCQRY application task global variables (SUBSxxxxx task global variables).

Table 4. AOCQRY Subsystem Task Global Variables

Task Global Variable	Description
SUBSAPPL	The application name from the automation control file. If <i>stype</i> was coded, this task global variable contains the resource name.
SUBSASID	The address space ID of the application. This is only available when SA z/OS process monitoring is used for this resource.
SUBSCATEGORY	The subsystem category (for example, JES2, DB2, IMS, USS, etc.).
SUBSCMDPFX	The application command prefix from the automation control file.
SUBSDISC	The application description from the automation control file.
SUBSEXTSTART	Contains the 'External Start' information.
SUBSEXTSTOP	Contains the 'External Stop' information.
SUBSFILE	Contains the information whose file this resource represents.
SUBSINFOLINK	The application INFOLINK from the automation control file.
SUBSIPOPT	The application IPL option from the automation control file.
SUBSJOB	The application job name from the automation control file.
SUBSJOBTYPE	The subsystem jobtype from the automation control file (MVS/NONMVS/TRANSIENT).
SUBSMDATE	The date the last monitor cycle checked the subsystem.
SUBSMTIME	The time the last monitor cycle checked the subsystem.
SUBSOPER	The work operator assigned to the subsystem.
SUBSPARENT	A list of the application parent names from the automation control file. The parent names are separated by blanks. This is only provided if dependencies with a sequence number were specified in the dialog.
SUBSPATH	Contains the information whose z/OS UNIX process this resource represents.
SUBSPID	The ID for the USS process.
SUBSPORT	Contains the information whose TCP port this resource represents.
SUBSPROC	Contains the subsystem's PROCNAME.
SUBSPROCESS	Contains the current process (START, STOP, or null).
SUBSRSTOPT	The application restart information from the automation control file.

AOCQRY

Table 4. AOCQRY Subsystem Task Global Variables (continued)

Task Global Variable	Description
SUBSSCHEDSS	The application scheduling subsystem from the automation control file. If not specified, it defaults to the primary scheduling subsystem.
SUBSSDATE	The date the status of the subsystem was last updated.
SUBSSESS	The subsystem name from the automation control file.
SUBSSHUTDLY	The application shutdown delay value from the automation control file.
SUBSSPARM	The application parameter data from the automation control file.
SUBSSTARTTYPE	The application start type. This value is only available if the application is currently in a start phase.
SUBSSTAT	The application status from the automation status file.
SUBSSTIME	The time the status of the subsystem was last updated.
SUBSSTOPTYPE	The application stop type. This value is only available if the application is currently in a stop phase.
SUBSSTRTCYC	The application start cycles from the automation control file.
SUBSSTRTDLY	The application start delay from the automation control file.
SUBSSUBCAT	The subsystem subcategory (for example, tracker, TOR, AOR, etc.).
SUBSSUBID	The subsystem ID of the application as defined in the customization dialog.
SUBSSUBTYPE	The subsystem type (JES2, JES3, DB2®, CICS®, or IMS™). Note: This task global variable is obsolete and is provided only for compatibility. Use SUBSCATEGORY instead.
SUBSTERMDLY	The application termination delay from the automation control file.
SUBSTRANTY	Used by transient subsystems to indicate whether they can be rerun.
SUBSTYPE	This task global variable indicates the resource that automation flag checking is performed for. For an application, the value for this task global variable is SUBSYSTEM. For resources other than applications, the value for this task global variable is the value coded for <i>stype</i> on the AOCQRY call. If an application entry was not found, the task global variable value is NONE.
SUBSUSER	Contains the information whose z/OS UNIX user ID this resource belongs to.
SUBSUSSJOB	The real job name of the application. This is only available when SA z/OS process monitoring is used for this resource.
SUBSWLMNAME	A list of the workload manager names from the automation control file.
SUBSWTOR	The list of reply IDs of primary outstanding WTORs of the application.

Table 5 lists AOCQRY parent task global variables (SUBPxxxx task global variables).

Table 5. AOCQRY Parent Task Global Variables

Task Global Variable	Description
SUBPAPPL	The parent application name.

Table 5. AOCQRY Parent Task Global Variables (continued)

Task Global Variable	Description
SUBPASID	The parent address space ID. This is only available when SA z/OS process monitoring is used for this resource.
SUBPCATEGORY	The parent subsystem category (for example, JES2, DB2, IMS, USS, etc.).
SUBPCMDPFX	The parent command prefix from the automation control file.
SUBPDESC	The parent description
SUBPEXTSTART	Contains the 'External Start' information.
SUBPEXTSTOP	Contains the 'External Stop' information.
SUBPFILE	Contains the information whose file the parent represents.
SUBPINFOLINK	The parent INFOLINK from the automation control file.
SUBPIPLOPT	The parent IPL option from the automation control file.
SUBPJOB	The parent job name.
SUBPJOBTYPE	The parent subsystem jobtype from the automation control file (MVS/NONMVS/TRANSIENT).
SUBPMDATE	The date the last monitor cycle checked the parent subsystem.
SUBPMTIME	The time the last monitor cycle checked the parent subsystem.
SUBPOPER	The work operator assigned to the parent.
SUBPPARENT	A list of the parent names from the automation control file. The parent names are separated by blanks. This is only provided if dependencies with a sequence number were specified in the dialog.
SUBPPATH	Contains the information whose z/OS UNIX process the parent represents.
SUBPPID	The ID for the USS process of the parent.
SUBPPORT	Contains the information whose TCP port the parent represents.
SUBPPROC	Contains the subsystem's PROCNAME.
SUBPPROCESS	Contains the current process (START, STOP, or null).
SUBPRSTOPT	The parent restart information
SUBPSCHEDSS	The scheduling subsystem for the parent, from the automation control file. If not specified, it defaults to the primary scheduling parent.
SUBPSDATE	The date the status of the parent system was last updated.
SUBPSESS	The parent subsystem name from the automation control file.
SUBPSHUTDLY	The parent shutdown delay value
SUBPSPARM	The parent parameter data
SUBPSTAT	The parent status
SUBPSTARTTYPE	The application start type. This value is only available if the application is currently in a start phase.
SUBPSTIME	The time the status of the parent system was last updated.
SUBPSTOPTYPE	The application stop type. This value is only available if the application is currently in a stop phase.

AOCQRY

Table 5. AOCQRY Parent Task Global Variables (continued)

Task Global Variable	Description
SUBPSTRTCYC	The parent start cycles from the automation control file.
SUBPSTRTDLY	The parent start delay from the automation control file.
SUBPSUBCAT	The parent subsystem subcategory (for example, tracker, TOR, AOR, etc.).
SUBPSUBID	The subsystem ID of the application as defined in the customization dialog.
SUBPSUBTYPE	The subsystem type of the parent subsystem.
SUBPTERMDLY	The parent termination delay from the automation control file.
SUBPTRANTY	If the parent subsystem is a transient, this indicates whether it can be rerun.
SUBPTYPE	This task global variable indicates the resource that automation flag checking is performed for. For an application, the value for this task global variable is SUBSYSTEM. For resources other than applications, the value for this task global variable is the value coded for <i>stype</i> on the AOCQRY call. If an application entry was not found, the task global variable value is NONE.
SUBPUSER	Contains the information whose z/OS UNIX user ID the parent belongs to.
SUBPUSSJOB	The real parent job name. This is only available when SA z/OS process monitoring is used for this resource.
SUBPWLMNAME	A list of the workload manager names from the automation control file.
SUBPWTOR	A list of reply IDs of primary outstanding WTORs of the application.

Note: The SUBP variables are only available if dependencies with a sequence number were specified in the customization dialog.

Table 6 lists AOCQRY automation flag task global variables.

Table 6. AOCQRY Automation Flag Task Global Variables

Task Global Variable	Description																		
AUTOTYPE	<p>The AUTOTYPE task global variable contains the value of the automation mode that is turned off. Depending on certain conditions, AUTOTYPE has the following values:</p> <table border="1"> <thead> <tr> <th>Value</th> <th>Condition</th> </tr> </thead> <tbody> <tr> <td>Null</td> <td>Automation is allowed.</td> </tr> <tr> <td>Null</td> <td><i>request_type</i> does not check automation flags.</td> </tr> <tr> <td>GLOBAL</td> <td>The Automation (global) automation flag is off.</td> </tr> <tr> <td>INITSTART</td> <td>Initstart automation flag is off.</td> </tr> <tr> <td>RECOVERY</td> <td>Recovery automation flag is off.</td> </tr> <tr> <td>RESTART</td> <td>Restart automation flag is off.</td> </tr> <tr> <td>START</td> <td>Start automation flag is off.</td> </tr> <tr> <td>TERMINATE</td> <td>Shutdown automation flag is off.</td> </tr> </tbody> </table>	Value	Condition	Null	Automation is allowed.	Null	<i>request_type</i> does not check automation flags.	GLOBAL	The Automation (global) automation flag is off.	INITSTART	Initstart automation flag is off.	RECOVERY	Recovery automation flag is off.	RESTART	Restart automation flag is off.	START	Start automation flag is off.	TERMINATE	Shutdown automation flag is off.
Value	Condition																		
Null	Automation is allowed.																		
Null	<i>request_type</i> does not check automation flags.																		
GLOBAL	The Automation (global) automation flag is off.																		
INITSTART	Initstart automation flag is off.																		
RECOVERY	Recovery automation flag is off.																		
RESTART	Restart automation flag is off.																		
START	Start automation flag is off.																		
TERMINATE	Shutdown automation flag is off.																		
EHKEXITRSN	The return code from the exit if a nonzero return code.																		
EHKEXITNME	The name of the exit supplying the nonzero return code.																		

Table 6. AOCQRY Automation Flag Task Global Variables (continued)

Task Global Variable	Description
I SUBSASSIST	The Assist Mode setting for the automation flag.

Examples

Example 1

This example shows how AOCQRY can be used in an automation procedure to check whether automation is allowed for an application, before invoking automation actions.

Assume that the CICST subsystem issues a message during termination that invokes this automation procedure by means of a NetView automation table statement. Further assume that the message identifier is not considered for the automation decision.

The automation procedure to call AOCQRY is:

```

/* REXX CLIST to check if termination automation is allowed for CICST      */
'AOCQRY CICST,TERMINATE'
Select
  When rc = 0 Then Do              /* Automation on; perform actions req'd.  */
    :
  End
  When rc = 1 | rc = 2 Then Do /* Automation off; If applicable log a
                                message indicating unable to take
                                action for message.
                                */
    :
  End
  When rc = 3 Then Exit          /* Subsystem not automated                */
  Otherwise Do                  /* Error; log error message              */
    :
  End
End
Exit

```

The automation procedure performs the following processing steps:

1. The automation procedure calls AOCQRY, supplying CICST as the subsystem name and TERMINATE as the *request_type*. AOCQRY retrieves the appropriate subsystem information, and then searches for the automation flags.
2. After returning from AOCQRY, the automation procedure determines what the return code was, then takes the appropriate action.

Supposing that the subsystem CICST has a HasParent relationship to VTAM, AOCQRY accesses both the definitions of CICST and VTAM to fill in the task global variables. All the SUBSxxxx task global variables are filled with the CICST subsystem information, and the SUBPxxxx task global variables are filled with the VTAM information.

Example 2

The automation procedure from Example 1 can be coded in a more generic way by using the NetView REXX function jobname() as the resource option of AOCQRY.

The automation procedure to call AOCQRY is:

```

/* REXX CLIST to check if termination automation is allowed for a job
- generic check dependant on Jobname
*/
'AOCQRY 'Jobname()',TERMINATE'
Select
  When rc = 0 Then Do              /* Automation on; perform actions req'd.  */
    :
  End
  When rc = 1 | rc = 2 Then Do /* Automation off; If applicable log a
                                message indicating unable to take
                                action for message.
                                */
    :
  End
End

```

```

End
When rc = 3 Then Exit      /* Subsystem not automated      */
Otherwise Do              /* Error; log error message */
:
End
End
Exit

```

The `jobname()` function returns the name of the job that has issued the message. Using this function, the automation procedure supports any job that can issue the message that invokes this automation procedure via the NetView automation table. This allows portability of the automation procedure to different systems without requiring changes to it. The job name is supplied only to an automation procedure that is called from the NetView automation table.

If your automation procedure issues MSGREAD commands, you must issue the `jobname()` function upon entry because the returned value resets whenever the MSGREAD command is issued.

Example 3

This example shows how AOCQRY can be used in an automation procedure to check whether automation is allowed for an MVS component, before invoking automation actions.

The message to automate is issued by MVS indicating that an SMF dump data set is full. The automation procedure verifies that automation is allowed by calling AOCQRY.

The automation procedure to call AOCQRY is:

```

/* REXX CLIST to check if recovery automation is allowed for SMF      */
'GLOBALV GETC AOFSYSTEM'
'AOCQRY SMFDUMP,RECOVERY,'aofsystem
Select
  When rc = 0 Then Do      /* Automation on; perform actions req'd.  */
  :
  End
  When rc = 1 | rc = 2 Then Do /* Automation off; If applicable log a
                                message indicating unable to take
                                action for message.          */
  :
  End
  Otherwise Do            /* Error; log error message      */
  :
  End
End
Exit

```

This example differs from the previous examples as follows:

- When automating an MVS component, use a generic component as the resource name when calling AOCQRY instead of a message identifier. Thus several messages can be related to a single MVS component to be automated.
- The third parameter *stype* is coded. Coding *stype* tells AOCQRY to skip the process of finding subsystem entries. The example uses the AOFSYSTEM common global variable as the *stype* parameter. The value of the variable is MVSESA.
- Return Code 3 is not valid because the application entries in the automation control file are not checked.

AOCUPDT

Purpose

AOCUPDT performs several status update functions, including:

- Updating the automation agent status for the resource
- Identifying any messages associated with the automation agent status change and processing options performed for these messages:
 - Whether a message is issued and logged in the NetView log
 - Which message is issued
 - Whether the message is sent as a notification message to notification operators on a local system (distinct from forwarding to a focal-point system)
 - Whether the message is forwarded to a focal-point system

AOCUPDT calls common routine AOCMSG to handle processing of log and notification messages.

- Updating SDF status displays with the resource status change
- Updating the automation manager OBSERVED status

Syntax

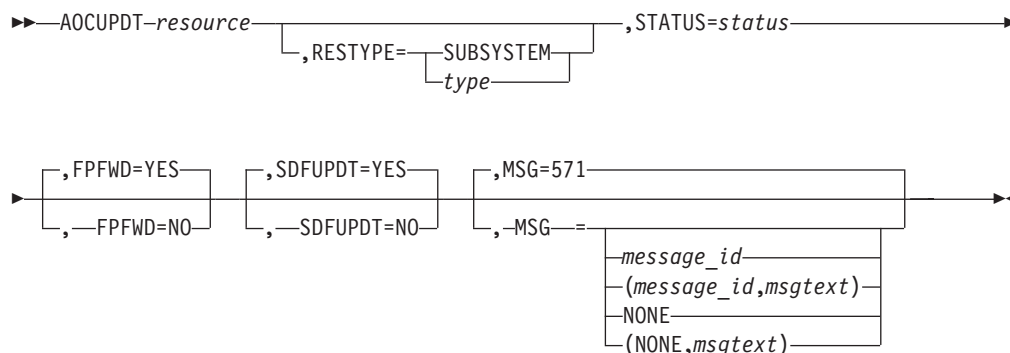

Parameters

resource

The name of the resource that status or information updates specified by other AOCUPDT parameters are performed for. This value is required and must be specified first on an AOCUPDT call. You can use the following formats for *resource*. Use the *inresource* variable to specify a resource that the resource is dependent on, that is, the parent resource.

Format	Example
<i>system_name.resource/inresource</i>	PROD.TSO/VTAM
<i>resource/inresource</i>	TSO/VTAM
<i>system_name.resource</i>	PROD.TSO
<i>resource</i>	TSO

The *system_name* variable defaults to AOFSSYSNAME. The *inresource* variable defaults to the RESTYPE value. The specification or default to a value of SUBSYSTEM for *inresource* will result in a value of SUBSYS being used.

RESTYPE

Identifies the type of resource for the *resource* parameter. You can specify a resource type of your own choice, with the exception of SYSTEM, which is reserved for internal use only. The default is SUBSYSTEM.

type

A resource type of your own choice

SUBSYSTEM

A resource type of SUBSYSTEM

STATUS

Specifies the new value of the automation agent status for the resource.

When you use this parameter to change status, some other AOCUPDT parameters perform default actions, unless otherwise coded. These parameters include:

- MSG
- FPFWD
- SDFUPDT

If you specify STATUS to change status, but do not specify any of the parameters listed above (thereby using parameter defaults), the following occurs:

- SA z/OS issues message AOF571I, *resource_name* SUBSYSTEM STATUS FOR JOB *jobname* IS *status—text* and also logs the message in the NetView log.
- The specified status change is reflected in SDF status panels.

To change the values or actions performed by the MSG, FPFWD, and SDFUPDT parameters, or to preclude their use, you must specify those parameters and desired values.

If a status value that has a length greater than eight characters is used, the status value is truncated to a length of eight characters.

FPFWD

Determines whether the specified status is sent from a local system (the system that AOCUPDT is issued on) to a focal-point system.

YES

The status is sent. This is the default.

NO

The status is not sent.

Note: For status forwarding to a focal-point system to occur, you must already have configured an automation network and defined the automation network to SA z/OS. Refer to *IBM Tivoli System Automation for z/OS User's Guide* for details.

SDFUPDT

Determines whether the specified status change is also reflected in SDF status displays.

YES

The status change is reflected in SDF status displays. This is the default if STATUS is specified.

NO

The status change is not reflected in SDF status displays. This is the default if STATUS is not specified.

MSG

This parameter identifies the message associated with the status change specified on the STATUS parameter. This message is issued to note when the status change occurs. This parameter is applicable only if the STATUS parameter is also specified.

The default is 571, the message ID for SA z/OS status change message AOF571I, *resource_name* SUBSYSTEM STATUS FOR JOB *jobname* IS *status*—*text*.

This parameter value can be specified using the following formats:

message_id

Identifies the numeric part of a message ID. For example, 571 specifies SA z/OS message AOF571I.

(*message_id*)

The complete message ID, including message prefix and message number, enclosed in parentheses, for example, (AOF123).

(*message_id,msgtext*)

The complete message ID, including message prefix and message number, plus message text to be substituted for message variables in the message text. This entire specification is enclosed in parentheses, for example, (123,AA,BB,CC). Quotation marks are not allowed in the message text.

The AOCMSG common routine substitutes the message text values into message variables &1 through &9 in the fixed message text located in the NetView message library. See “AOCMSG” on page 34 for details about how this common routine works. Some message variables are preset to certain values depending on the message ID and message text specified on the AOCUPDT call. The following details how the message variables are preset.

- Variable &1 is always set to AOFRUPDT, which is the name of the automation procedure that the AOCUPDT command processor resides in.
- If the message text is omitted, the following message variables are preset:

Var	Setting
&1	AOFRUPDT
&2	Time
&3	<i>system_name.resource</i>
&4	Resource type
&5	Subsystem name
&6	Subsystem job name
&7	Status

- If the message text is provided and the *message_id* number is 571, the following message variables are preset:

Var	Setting
&1	AOFRUPDT
&2	Time
&3	<i>system_name.resource</i>
&4	Resource type

- &5 Subsystem name
- &6 Subsystem job name
- &7 Status

Variables &8 and &9 can be assigned values from the *msgtext* portion of this parameter.

- If the message text is provided and the *message_id* number is not 571, the following message variables are preset:

- | Var | Setting |
|-----|-----------------------------|
| &1 | AOFRUPDT |
| &2 | Time |
| &3 | <i>system_name.resource</i> |
| &4 | Resource type |

Variables &5 through &9 can be assigned values from the *msgtext* portion of this parameter.

NONE

The operator is not notified that the update has taken place. The text string "RESOURCE *resource_name* STATUS UPDATED TO *status_value*" is written to SDF.

(NONE,*msgtext*)

The operator is not notified that the update has taken place. The text string "*msgtext*" is written to SDF.

Restrictions and Limitations

AOCUPDT has the following restrictions and limitations:

- Use AOCUPDT instead of ASF to perform dynamic status updates to SA z/OS status files.
- AOCUPDT should only be issued from an automation procedure.
- Parentheses appearing within message text must be properly paired and balanced.
- Using AOCUPDT to change a resource status *only* changes the status. It does not initiate any associated status change processing that occurs if the status change is processed through a generic routine such as ACTIVMSG or TERMMSG. Also, the automation status remains unchanged. For example, if the resource is involved in a STARTUP, and the resource's status is changed to UP via AOCUPDT, this process will not be affected because the automation status will not be changed to IDLE.

Return Codes

- 0 AOCUPDT processed normally.
- 4 All requested actions were performed. However, the system detected that some of the data to be changed was the same as the modified data specified on the AOCUPDT call.
- 8 Incorrect keyword specifications were detected and ignored. All other keywords processed normally.
- 12 No function keyword was specified on the AOCUPDT call. A resource was identified, but no action to perform on the resource was specified.

AOCUPDT

- 16 The specified *resource* was not found, when the specified resource type (RESTYPE value) is SUBSYSTEM and the system name is the system that AOCUPDT is running on.
- 20 The *resource* name length was longer than allowed. When the specified RESTYPE value is SUBSYSTEM, the resource name cannot be longer than 11 characters.
- 99 A timeout or another error occurred.

Usage

- Use this command instead of ASF to update SA z/OS status information.
- When you use AOCUPDT to change resource status, the status change message is sent to notification operators defined to receive the message. Notification of a status change occurs whether automation flags for the resource are enabled or disabled (set to Yes or No). To suppress sending a message when a status change occurs, specify MSG=NONE along with the STATUS parameter.

Examples

Example 1

This example shows how to use AOCUPDT to change the status of the TSO subsystem to UP.

```
AOCUPDT TSO,STATUS=UP
```

Note: This will not cause any TSO UP commands to be issued.

Example 2

This example shows how to use AOCUPDT to:

- Change the status of subsystem IMSPROD to DOWN
- Issue a customer-defined message, ABC123
- Ensure that the status change is *not* reflected in SDF

```
AOCUPDT IMSPROD,STATUS=DOWN,MSG=ABC123,SDFUPDT=NO
```

Note: You should not change the status in this way if IMSPRODU is running.

AOFEXCMD

Purpose

AOFEXCMD is used to execute a command on a specified autotask. If the autotask is not active, AOFEXCMD will try to execute the command on a backup autotask. This process is repeated until the command is successfully scheduled for execution, or the list of available backup autotasks is exhausted.

AOFEXCMD will attempt to execute the command on the following autotasks:

1. The primary autotask for *autofunc*
2. The secondary autotask for *autofunc*
3. The primary autotask for SYSOPER
4. The secondary autotask for SYSOPER
5. The primary autotask for BASEOPER
6. The primary autotask for AUTO1

If it cannot execute on any of these autotasks, an AOF572I message is issued.

SA z/OS automation will attempt to restart any inactive autotasks called by AOFEXCMD.

Syntax

▶▶ AOFEXCMD *autofunc* , *command* ▶▶

Parameters

autofunc

The automated function that the autotask name is defined under. Automated functions are established in the customization dialogs, and are assigned at SA z/OS initialization.

If the automated function name is not supplied the procedure will attempt to issue the command on one of the backup automated functions (SYSOPER, BASEOPER or AUTO1)

Note: If the automated function name is not supplied, a comma must be used as a placeholder for parsing so that the command is identifiable as the second operand.

command

The command that is to be scheduled to run on the autotask associated with the automated function.

Restrictions and Limitations

Do not define an operator ending with the character string #\$.

Issuing operators must be authorized to issue the command using EXCMD.

Messages

The following message is issued by AOFEXCMD when it has failed to execute on any of the available autotasks. This may occur if AOFEXCMD is issued before SA z/OS initialization is complete.

```
AOF572I CGLOBALS NOT INITIALIZED FOR AUTOMATED FUNCTION autofunc -
UNABLE TO ROUTE COMMAND command, operand_1, operand_2, operand_3
```

Example

The following command schedules a message to be sent from autotask AUTNET1 to operator OPER1. In this example, AUTNET1 is defined under the automated function NETOPER.

```
AOFEXCMD NETOPER,MSG OPER1 Logoff in 5 mins
```

AOFSET

Purpose

The AOFSET routine is used to set the agent resource attributes of a given subsystem on the specified system.

Syntax

▶▶—AOFSET—*system*—*subsystem*—*function*—▶▶

Parameters

system

The system that the agent resource parameters are to be changed on.

subsystem

The subsystem that the agent resource parameters are to be changed for.

function

The agent resource parameters that are to be changed. The following values can be specified:

ABENDING

Set the next stop of the subsystem to ABENDING.

BREAKING

Set the next stop of the subsystem to BREAKING.

Restrictions and Limitations

ABENDING and BREAKING can only be used for subsystems with automation status ACTIVE.

Return Codes

- 0 OK.
- 1 An error occurred. The cause of the error is described in the error message.
- 6 Environment not initialized.

AOFTREE

Purpose

The AOFTREE routine is used to extract information about an application and its dependent applications. The information returned for each application in the parent child hierarchy is:

- Name
- Job name
- Type of the resource (can be application group or subsystem)
- Position in the tree

The relationship of an application to its dependent applications can be illustrated using a tree structure as in Figure 2 on page 59.

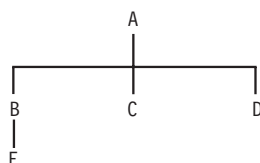
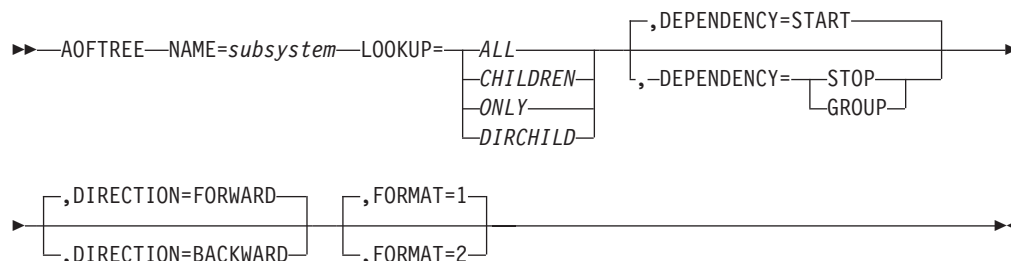

Figure 2. Subsystem Dependent Tree.

Where:

- A, B, C, D, and E are all applications.
- A is the root of the tree. All applications below A are its dependants.
- B, C, and D are direct children of A, that is, dependent on A.
- B, C, D, and E are all dependants of A.
- A is the parent of B, C, and D. B is the parent of E.
- A is on level 1, B, C, and D are on level 2, and E is on level 3.
- E, C, and D have a position in the tree referred to as 'LOWEST'. A and B have a position in the tree referred to as 'UPPER'.

Syntax



Parameters

NAME=

subsystem

The name of the application that you want to extract dependent applications for.

LOOKUP=

The scope of the tree to be returned. The following values can be specified for lookup:

ALL

Returns details about the application and all its children.

CHILDREN

Returns details about all the children of the application.

ONLY

Returns details about the application only.

DIRCHILD

Returns details about the application and its direct children.

DEPENDENCY

Specifies the type of dependency (as defined in the policy database) that the parent-child data should be returned for. The following options are available:

AOFTREE

START

Returns all resources that are a "parent" of the specified resource or that the resource has a start dependency on. This is the default.

STOP

Returns all resources that are a "child" of the specified resource or that the resource has a stop dependency on.

GROUP

Returns all members that the specified resource consists of.

DIRECTION

Specifies the direction for returning the tree data. The following options are available:

FORWARD

Means progressing from the top level of the tree towards the bottom. This is the default.

BACKWARD

Means progressing from the bottom of the tree towards the top.

FORMAT

Specifies the output format that the information is returned in. The following options are available:

- 1 The data is returned in NetView task global variables (AOFPCHILD.*n*). This is the default.
- 2 The data is returned in a multiline message.

Restrictions and Limitations

This command can only be issued for a local system.

Return Codes

- 0 The command successfully executed. The results are in the task global variable array, AOFPCHILD.
- 1 An invalid application name was used.
- 4 Invalid parameters were used.
- 5 Timeout or other error occurred.

Usage

When control is returned to the calling automation procedure, if the return code is not zero the AOFPCHILD array is set to null.

Note: The AOFPCHILD array is *not* sorted in hierarchical order.

If you use the AOFTREE command within a PIPE and no parameters are passed, the contents of the default safe is taken and treated as input parameters. The output format is set to 2 (FORMAT=2).

Task Global Variables

AOFPCHILD.0

The number of elements in the array.

AOFPCHILD.n

The nth element in the AOFPCHILD array. This element contains the following details for a subsystem, separated by blanks:

- Name
- Job name
- Position in the tree

Examples

The following results are obtained when calling AOFTREE with the following parameters, and the relationships between A, B, C, D, and E are as described in Figure 2 on page 59.

AOFTREE NAME=A,LOOKUP=ALL**AOFPCHILD.0**

= 5

AOFPCHILD.1

= E Ejobname 0 LOWEST

AOFPCHILD.2

= B Bjobname 0 UPPER

AOFPCHILD.3

= C Cjobname 0 LOWEST

AOFPCHILD.4

= D Djobname 0 LOWEST

AOFPCHILD.5

= A Ajobname 0 UPPER

AOFTREE NAME=A,LOOKUP=ONLY**AOFPCHILD.0**

= 1

AOFPCHILD.1

= A Ajobname 0 LOWEST

AOFTREE NAME=A,LOOKUP=DIRCHILD**AOFPCHILD.0**

= 4

AOFPCHILD.1

= A Ajobname 0 UPPER

AOFPCHILD.2

= B Bjobname 0 UPPER

AOFPCHILD.3

= C Cjobname 0 LOWEST

AOFPCHILD.4

= D Djobname 0 LOWEST

AOFTREE NAME=B,LOOKUP=ALL**AOFPCHILD.0**

= 2

AOFPCHILD.1

= E Ejobname 0 LOWEST

AOFTREE

AOFPCHILD.2

= B Bjobname 0 UPPER

If you issue:

```
'PIPE NETVIEW AOFTREE NAME=TSPARENT,LOOKUP=ALL,FORMAT=2,DEPENDENCY=START',  
'|STEM treedata.'
```

the contents of the treedata stem will look similar to the following:

```
TSPARENT/APL/AOC9 TSPARENT APL UPPER  
STDT005AA00/APL/AOC9 T005AA00 APL LOWEST  
STDT004AA00/APL/AOC9 T004AA00 APL LOWEST  
STDT003AA00/APL/AOC9 T003AA00 APL LOWEST  
STDT002AA00/APL/AOC9 T002AA00 APL LOWEST  
STDT002AA01/APL/AOC9 T002AA01 APL UPPER  
STDT001AA00/APL/AOC9 T001AA00 APL LOWEST
```

If you issue:

```
'PIPE NETV AOFTREE NAME=STDT000AN10,LOOKUP=ALL,FORMAT=2,DEPENDENCY=START',  
'|STEM treedata.'
```

the contents of the treedata stem will look similar to the following:

```
STDT000AN1A/APL/AOC9 #000AN1A APL UPPER  
STDT000AN1B/APL/AOC9 #000AN1B APL LOWEST  
STDT000AN1X/APL/AOC9 #000AN1X APL LOWEST  
STDT000AN10/APL/AOC9 #000AN10 APL UPPER  
STDT000AN11/APL/AOC9 #000AN11 APL LOWEST  
STDT000AN12/APL/AOC9 #000AN12 APL LOWEST
```

ASF

Purpose

| The ASF command is a file manager command that displays, adds, updates or
| deletes records in an automation status file. The automation status file records are
| maintained in a VSAM data set. ASF interfaces with the VSAM file to maintain
| control information vital to SA z/OS such as:

- Automation status
- Time and date information for specific events within the lifecycle of an application
- Whether an error threshold is exceeded
- Time and date information for error conditions

The ASF command is pipeable.

Recommendations

- In automation procedures you create, use the AOCUPDT common routine instead of ASF to modify application status. Changing application status using ASF may lead to unpredictable results.
- The primary use of ASF as an operator command is to display entries in an automation status file rather than change its contents. You can also display the automation status file using the DISPASF SA z/OS operator dialog, documented in *IBM Tivoli System Automation for z/OS Operator's Commands*. The ASF command also allows adding, updating, displaying, and deleting automation status file records, but these uses of ASF are not recommended. Modifications to the automation status file using ASF may not be acted upon or noticed by SA z/OS. Instead, use the SETSTATE operator dialog, described in *IBM Tivoli System Automation for z/OS User's Guide*, if at an operator console, or use the AOCUPDT common routine in automation procedures.
- Use command authorization to limit the use of this command to performing the display operation.

Syntax

The following syntax diagrams show how to use the ASF command to perform the different functions ASF supports. Do not combine syntax from the separate presentations in the same ASF call.

To display a single automation status file entry, or multiple automation status file entries, use the following syntax:

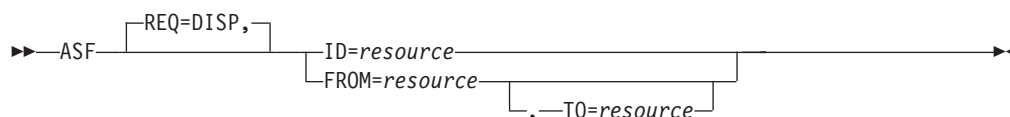

To delete a single automation status file entry use the following syntax:



To replace (or update) an automation status file entry use the following syntax:

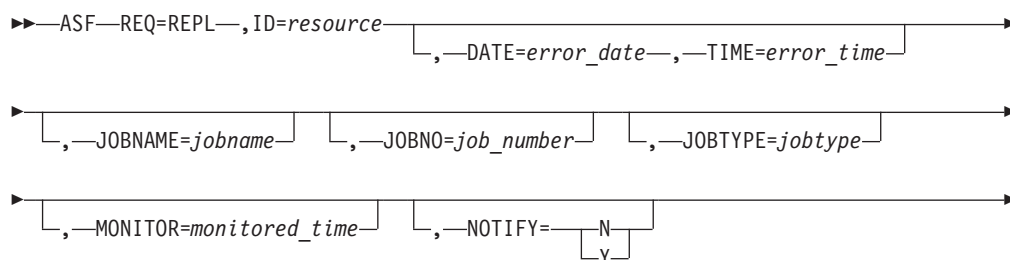

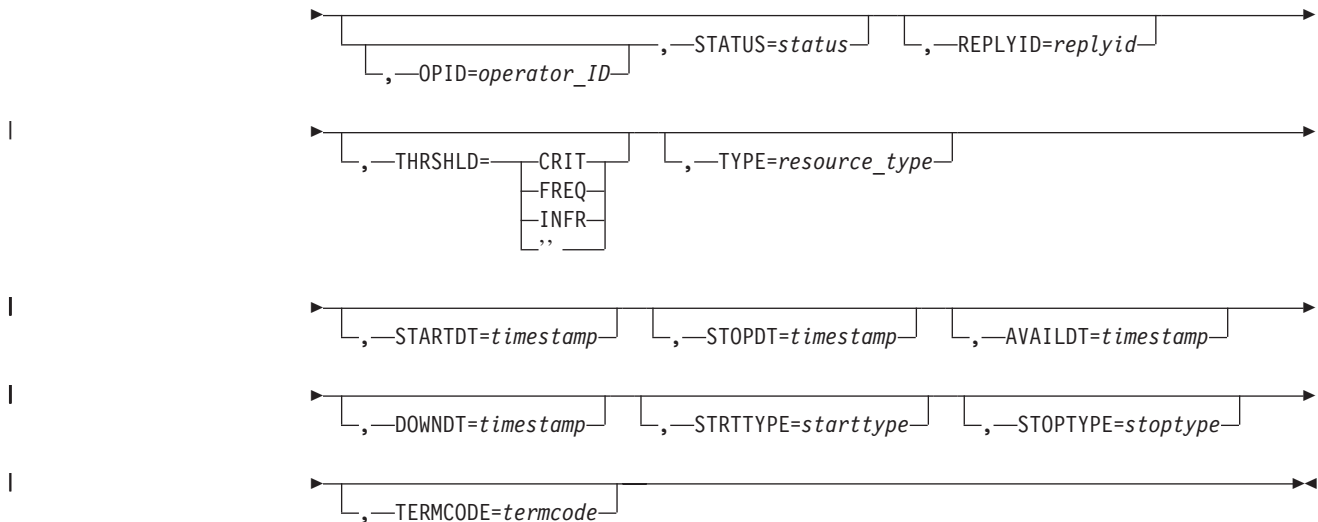

Parameters

REQ

The type of request for automation status file information the ASF command performs. This value may be one of the following:

DISP

Displays information in the automation status file. This value is the default if the REQ parameter is not coded.

DEL

Deletes information in the automation status file. This value must be coded when using ASF to delete automation status file information. If you use REQ=DEL, any other parameters specified besides ID are ignored.

REPL

Replaces or adds information in the automation status file. This value must be coded when using ASF to replace automation status file information. REPL adds a record to the automation status file if that entry does not already exist.

ID The resource ID that is the key to the automation status file record. This ID is the application name for application records. This value can be from 1 through 64 characters long.

FROM

The resource ID that is the starting key when displaying multiple automation status file records. This resource is the application name for application records. This value can be from 1 through 64 characters long.

TO

The resource ID that is the ending key when displaying multiple automation status file records. If not specified, the value defaults to the FROM parameter value. This resource is the application name for application records. This value can be from 1 through 64 characters long.

If a resource ID is specified, the records that are to be displayed are resolved alphabetically.

DATE

The date that this error time stamp is recorded, in *mm/dd/yyyy* format. Use this

value to monitor errors during a particular time period. The DATE and TIME parameters must both be specified, that is, if you specify DATE, you must also specify TIME.

TIME

The time of this error time stamp being recorded, in *hh:mm* format. Use this value to monitor errors during a particular time period. The DATE and TIME parameters must both be specified, that is, if you specify TIME, you must also specify DATE.

JOBNAME

The job name that the status update applies to. This value can be from 1 through 8 characters long.

JOBNO

The MVS-supplied job number for the currently active task.

JOBTYPE

The type of job: TSO user, STC, or JOB. Retain this value for job number checking.

MONITOR

The time a status change command is issued, in *hh:mm* format (00:00 through 23:59).

NOTIFY

Specifies whether a notification message is sent to the operator for a specified condition.

N A notification message is not sent.

Y A notification message is sent.

OPID

The NetView operator ID that requested or is performing the status update. If not supplied, the ASF command uses the current operator ID. This parameter is applicable only when you use the STATUS parameter. *operator_id* can be from 1 through 8 characters long.

STATUS

The automation agent status of the resource. This value can be from 1 through 8 characters long, and can be any valid status value. Refer to *IBM Tivoli System Automation for z/OS Customizing and Programming* for more information on resource statuses and their use.

When REQ=REPL, and the entry to be added or replaced does not exist, this parameter defaults to a value of DOWN.

REPLYID

The outstanding reply identifier for a subsystem. Use this value for retaining reply identifiers for applications that maintain an outstanding reply, such as NetView message DSI802I.

THRSHLD

The threshold that is exceeded. Use this value to allow the operator to monitor thresholds. Threshold can be CRIT, FREQ, or INFR. Specify '' (two single quotation marks) to delete the threshold value.

TYPE

The resource type for display and summary purposes. Other values can be defined, if desired. This value can be from 1 through 10 characters long.

If this parameter is omitted when REQ=REPL it creates a new record with the value UNKNOWN.

STARTDT

Specifies the date and time when the start order was received from the automation manager. The format is `yyyymmddhhmmss`. Specifying '' as the value for a keyword resets the keyword attribute in the Status File to its initial setting, for example, `ASF REQ=REPL, ID=name, STRTTYPE='', TERMCODE=''`.

STOPDT

Specifies the date and time when the stop order was received from the automation manager. The format is `yyyymmddhhmmss`. Specifying '' as the value for a keyword resets the keyword attribute in the Status File to its initial setting, for example, `ASF REQ=REPL, ID=name, STRTTYPE='', TERMCODE=''`.

AVAILDT

Specifies the date and time when the resource becomes available, as determined by the automation manager. The format is `yyyymmddhhmmss`. Specifying '' as the value for a keyword resets the keyword attribute in the Status File to its initial setting, for example, `ASF REQ=REPL, ID=name, STRTTYPE='', TERMCODE=''`.

DOWNDT

Specifies the date and time when the resource becomes unavailable, as determined by the automation manager. The format is `yyyymmddhhmmss`. Specifying '' as the value for a keyword resets the keyword attribute in the Status File to its initial setting, for example, `ASF REQ=REPL, ID=name, STRTTYPE='', TERMCODE=''`.

STRTTYPE

Specifies the last start type that was requested. Specifying '' as the value for a keyword resets the keyword attribute in the Status File to its initial setting, for example, `ASF REQ=REPL, ID=name, STRTTYPE='', TERMCODE=''`.

STOPTYPE

Specifies the last stop type that was requested. Specifying '' as the value for a keyword resets the keyword attribute in the Status File to its initial setting, for example, `ASF REQ=REPL, ID=name, STRTTYPE='', TERMCODE=''`.

TERMCODE

Specifies the last termination code (abend code). Specifying '' as the value for a keyword resets the keyword attribute in the Status File to its initial setting, for example, `ASF REQ=REPL, ID=name, STRTTYPE='', TERMCODE=''`.

Restrictions and Limitations

ASF functions both as an operator command and as an API to the automation status file. Limit its use as an operator command by scope-checking.

Usage

- If an automation procedure performs a replace or update function, only those fields that need replacing must be specified. No change occurs to other automation status file fields.
- To modify automation status file fields reserved for your data, use the ASFUSER command. See "ASFUSER" on page 67 for details.

Messages

The following messages are issued during successful operation of the ASF command.

For delete and replace requests:

```
AOF001I REQUEST "request" WAS SUCCESSFUL FOR "resource"
```

For display requests:

These messages use JES2 as an example status record that status information is displayed for. Message variables are filled with JES2 information.

```
AOF150I STATISTICS DISPLAY REQUESTED FOR JES2 THRU JES2
AOF151I ID= JES2 , TYPE= SUBSYSTEM , STATUS= UP
AOF152I LAST UPDATED BY OPERATOR AUTWRK02
AOF153I LAST START EVENT: TS= 09/26/2007 20:11:22 , TYPE= NORM
AOF153I LAST AVAIL EVENT: TS= 09/26/2007 20:11:50 , TYPE= NORM
AOF153I LAST STOP EVENT: TS= 09/26/2007 18:09:22 , TYPE= NORM
AOF153I LAST DOWN EVENT: TS= 09/26/2007 18:43:49 , TYPE= NORM
AOF163I LAST THRESHOLD EXCEEDED - CRIT
AOF155I OPERATOR NOTIFIED: N
AOF156I LAST STATUS CHANGE DATE= 09/26/2007 , TIME= 20:11 , OPID= AUTWRK02
AOF157I LAST MONITORED DATE= 09/26/2007 , TIME= 20:11
AOF160I ERROR COUNT DATE TIME
AOF161I 01 08/29/2007 19:16
AOF161I 02 08/30/2007 17:23
AOF161I 03 09/18/2007 13:15
AOF161I 04 09/18/2007 13:15
AOF002I END OF MULTI-LINE MESSAGE GROUP
```

The following messages are issued if the entry was not found.

For delete and replace requests:

An ASF replace request adds an entry if one does not exist, so a successful message would result.

For an ASF delete request, if ASF cannot find the identifier, it also issues a successful message.

```
AOF001I REQUEST "request" WAS SUCCESSFUL FOR "resource"
```

For display requests:

```
AOF041I UNABLE TO FIND RECORD identifier
```

Example

To display status information about subsystem JES2, enter:

```
ASF REQ=DISP ID=JES2
```

ASFUSER**Purpose**

The ASFUSER command is a file manager command that updates the ten user fields in the automation status file. The ASFUSER command has different formats depending on whether it is used to:

- Display multiple records
- Display, delete, or replace (update) a single record

The ASFUSER command is pipeable.

Syntax

To display single or multiple records use the following syntax:

ASFUSER

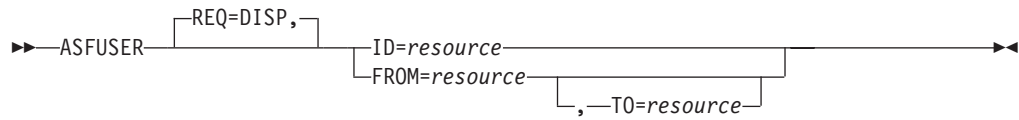

To delete a single record use the following syntax:



To replace (update) a record use the following syntax:

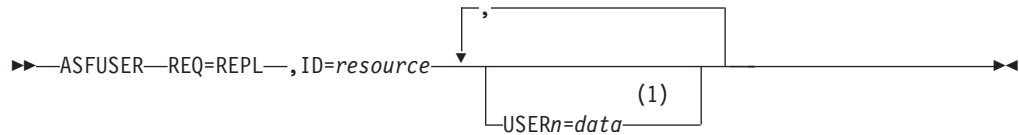

Notes:

- 1 *n* may be a number from 1 to 40

Parameters

REQ

The type of request for automation status file record information the ASFUSER command performs. This value may be one of the following:

Value

Description

DISP

Displays a record in the automation status file. This value is the default if the REQ parameter is not coded.

DEL

Deletes a record in the automation status file.

REPL

Replaces or adds a record in the automation status file.

If this parameter is specified, other parameters that describe the data to be displayed, deleted, or updated must be specified.

FROM

The resource ID that is the starting key when displaying multiple automation status file records. This value can be from 1 through 16 characters long.

TO

The resource ID that is the ending key when displaying multiple records. If not specified, the value defaults to the same key as the FROM parameter. This value can be from 1 through 16 characters long.

ID The resource ID that is the key to the automation status file record. This ID is the application name for application records. This ID can be from 1 through 16 characters long.

USER1=*data* ... USER40=*data*

These parameters specify data that is stored in each of the 40 fields in the automation status file that are reserved for your information. All these

parameters are optional. The specified data can be 1 through 20 characters long. These parameters are only used with ASFUSER replace requests (REQ=REPL).

Restrictions and Limitations

An ASFUSER command to replace or update automation status file entries is limited to 240 characters.

Usage

If your automation procedure performs a replace or update function, only those fields that need replacing must be specified. No change occurs to other automation status file fields.

Messages

- The following messages are issued during successful operation of the ASFUSER command.

- For delete and replace requests:

```
AOF001I REQUEST "request" WAS SUCCESSFUL FOR "resource"
```

- For display requests, the following messages are issued. These messages use status record MYRECORD as an example. Message variables are filled in with values for MYRECORD.

```
AOF150I STATISTICS DISPLAY REQUESTED FOR MYRECORD
```

```
AOF151I id=MYRECORD
```

```
AOF158I USER1=value
```

```
:
```

```
:
```

```
AOF158I USER40=value
```

```
AOF002I END OF MULTILINE MESSAGE
```

- The following message is issued if the entry was not found for an ASFUSER display request.

```
AOF041I UNABLE TO FIND RECORD identifier
```

Note: An ASFUSER replace request adds an entry if one does not exist, so a successful message would result. For an ASFUSER delete request, if ASFUSER cannot find the identifier, it also issues a successful message.

Examples

Example 1

This example shows a command to create an automation status file record for a resource with a resource ID of DASD.

The ASFUSER command to create the record is:

```
ASFUSER REQ=REPL, id=DASD, USER1=3350, USER2=3380
```

The response to the ASFUSER command is:

```
AOF001I REQUEST "REPLACE" WAS SUCCESSFUL FOR "DASD  "
```

Example 2

This example shows a command to display an automation status file record for DASD.

The ASFUSER command to display the record is:

ASFUSER

```
ASFUSER id=DASD
```

The response to the ASFUSER command is:

```
AOF150I STATISTICS DISPLAY REQUESTED FOR DASD
AOF151I id=DASD
AOF158I USER1=3350
AOF158I USER2=3380
AOF002I END OF MULTILINE MESSAGE
```

Example 3

This example shows a command to update the DASD automation status file record to add a new DASD device type.

The ASFUSER command to add a new field to the existing record is:

```
ASFUSER REQ=REPL,id=DASD,USER3=3990
```

The response to the ASFUSER command is:

```
AOF001I REQUEST "REPLACE" WAS SUCCESSFUL FOR "DASD  "
```

Note: Other values in record DASD remain as they were before the ASFUSER command was issued.

CDEMATCH

Purpose

The CDEMATCH routine performs a function similar to a table search. It uses code values specified in the automation policy to create a table. You define the table match criteria and a control keyword or result field. Results from the search are returned to the automation procedure and are typically used to alter the automation procedure logic flow or an automation procedure command or reply. A typical use is to extract feedback and return codes from the message you are automating, and then perform a search in the automation control file using those codes. The result of that search alters the action the automation procedure takes.

Syntax

```
→ CDEMATCH MSGTYP=type [ ,CODE1=code ] [ ,CODE2=code ] [ ,CODE3=code ]
→ [ ,ENTRY=entry ]
```

Parameters

MSGTYP=*type*

The criteria for the type field during the code search; it also relates to the type field in the automation control file. MSGTYP is typically coded with the message ID or with a generic name, such as SPOOLSHORT or SPOOLFULL.

CODE1=*code* CODE2=*code* CODE3=*code*

The criteria used during the search. At least one code must be supplied and all three can be supplied, if desired. The codes can be specified in any order. The code is normally derived from the message detail. CODE1 relates directly to field 1 of the automation control file CODE format, CODE2 relates directly to field 2, and CODE3 to field 3.

ENTRY=entry

The criteria for the entry field during the command search. This value also relates to the entry field in the automation control file. Values for the CDEMATCH task global variables named SUBSTYPE and SUBSAPPL determine the default for this parameter. See “Task Global Variables” for more information. If the SUBSTYPE task global variable value is SUBSYSTEM, the SUBSAPPL task global variable value is the default ENTRY value. Otherwise, the SUBSTYPE task global variable value is the default ENTRY value. The AOCQRY routine must be called before CDEMATCH for the defaults to work.

Restrictions and Limitations

This routine can be called only by another automation procedure or a command processor.

Return Codes

- 0 A match was found. The result is in task global variable field EHKACTION.
- 1 No match was found.
- 4 Incorrect parameters were used in the call.
- 5 Timeout or other error occurred.
- 6 SA z/OS initialization incomplete, unable to process command request.

Usage

- When control is returned to the calling automation procedure, task global variable EHKACTION contains the data from the Value Returned field in the Code Processing panel of the customization dialogs. If no match occurs, EHKACTION is null.
- Code matching specifications in the automation policy are order-dependent. The first match found is used.
- The format of code matching specifications in the automation policy allows the use of generic specifications, such as an asterisk (*), to indicate that all preceding or remaining characters are ignored. When performing a search using CDEMATCH, pass the full text of the code. CDEMATCH truncates and compares as necessary.
- Code parameters (CODE1, CODE2, or CODE3) not specified when calling CDEMATCH are considered as matching whatever exists in the automation policy.
- Refer to *IBM Tivoli System Automation for z/OS Customizing and Programming* for more information about the code matching feature.

Task Global Variables

EHKACTION

The data specified in the Value Returned field in the Code Processing panel of the customization dialogs. In the automation control file generated from this customization dialog field, this field follows the code matching data (Code 1, Code 2, and Code 3 fields).

When the return code for CDEMATCH is greater than zero, the EHKACTION value is null.

Example

This example shows the relationship between CDEMATCH and the automation control file. The message to automate, \$HASP095, is produced by the JES2 subsystem and indicates that a catastrophic-level problem has occurred. This example assumes the full message text is passed to the automation procedure. The automation procedure breaks the message apart, calls CDEMATCH to determine whether the error codes are in the automation control file.

The code matching information is specified in the automation policy as follows.

Select the MESSAGES/USER DATA policy item for the JES2 Application object. On the Message Processing panel for the JES2 subsystem enter CODE as the action for the message \$HASP095.

The Code Processing panel for message \$HASP095 is displayed, as shown in Figure 3.

Code 1	Code 2	Code 3	Value Returned
ERROR*	\$K03		IPLREQ
ERROR*	\$K08		IPLREQ
ERROR*	\$K15		IPLREQ
ABEND*	SA22		OPERCANCEL

Figure 3. Code Processing Sample Panel

The automation procedure is as follows:

```

/* REXX CLIST to respond to $HASP095 */
/* Check whether automation is allowed and set TGLOBALs */
'AOCQRY ..'
:
/* Get text of triggering message and save it in msg.1 */
'PIPE SAFE * | STEM msg.'

If msg.0 > 0 Then Do
  /* Parse the input message: */
  /* $HASP095 JES2 CATASTROPHIC type. CODE = cde RC=rc */
  Parse Var msg.1 'CATASTROPHIC' code1 . 'CODE =' code2 .
  /* Look for a match */
  'CDEMATCH MSGTYP=$HASP095, CODE1='code1', CODE2='code2
  Select
    When rc = 0 Then Do /* Match found: check the action field */
      'GLOBALV GETT EHKACTION'
      If ehkaction = 'IPLREQ' Then Do
        :
      End
    End
    When rc = 1 Then Do /* No match found: warn if required */
      :
    End
    Otherwise /* Error: perform warning action */
      :
    End
  End
End

```

The automation procedure gets the triggering message \$HASP095 from the PIPE default SAFE and stores the only message text line in stem variable *msg.1*. Then the message text is parsed using literal string patterns to extract the error type and the error code in variables *code1* and *code2*. Both values are used when CDEMATCH searches in the automation control file. According to the code specifications in the automation policy, CDEMATCH checks for the generic error code \$PJ in the first three characters. This generic error code traps both \$PJ2 and

\$PJF, which are P JES2,ABEND and \$P JES2,ABEND,FORCE, respectively. In addition CDEMATCH checks if message \$HASP095 contains error codes \$K03 or SA22.

In all these cases, STOPPING is returned as the value in the task global variable EHKACTION so that the appropriate action can be taken in the automation procedure.

When calling CDEMATCH, the ENTRY parameter is not coded and defaults to JES2. This default occurs only if AOCQRY was previously called and task global variable SUBSTYPE is properly filled in. Refer to "AOCQRY" on page 41 for more information.

CHKSUBS

Purpose

This command exists for compatibility reasons. The processing is done by the automation manager automatically as a result of the status updates. The return code is always 0.

CHKTHRES

Purpose

The CHKTHRES routine checks the number of errors recorded in the automation status file against a preset error threshold. It also supports recording the error date and time in the automation status file.

CHKTHRES searches the automation control file for the applicable threshold for a specific resource. It then obtains the error status information from the automation status file and determines, based on the thresholds, whether any of the three definable thresholds are exceeded. If a threshold is exceeded, an error message is issued and an appropriate return code is generated.

Syntax

Parameters are positional.

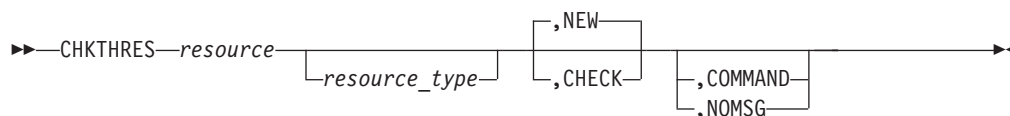

Parameters

resource

The name of the resource that thresholds should be checked for. This value can be a subsystem name, a subsystem minor resource such as CICS.TRAN.APPL1, a generic MVS component name such as MVSESA.SMF, or any name that you define up to 64 characters long.

For compatibility with former SA z/OS releases, the resource names MVSDUMP, SMFDUMP, LOGREC and SYSLOG are automatically prefixed with MVSESA.

CHKTHRES

This parameter is required.

resource_type

The type of the resource. Normally, SUBSYSTEM is used for applications, and MVSESA for MVS components. This value can be up to 10 characters long and be any name other than CHECK, NEW, COMMAND, NOMSG. It determines the search sequence for default threshold definitions.

This parameter is optional. If it is not specified, it is assumed to be SUBSYSTEM for resources that are defined as subsystems in SA z/OS and it is set to MVSESA in all other cases.

NEW

An error is added to the error status information; then thresholds are checked.

CHECK

Thresholds are checked based on the existing error information.

COMMAND

This parameter determines the messages that CHKTHRES issues when the infrequent, frequent, and critical error thresholds are exceeded and the resource type is either SUBSYSTEM or MVSESA.

If the automation procedure that you use CHKTHRES in issues commands when an error threshold is exceeded, specify this parameter.

NOMSG

This parameter determines that no messages are to be issued when the infrequent, frequent, and critical error thresholds are exceeded.

Restrictions and Limitations

None.

Return Codes

- 0 No threshold is exceeded
- 1 Infrequent threshold is reached
- 2 Frequent threshold is reached
- 3 Critical threshold is reached
- 4 Incorrect parameters were used in the call
- 5 Timeout or other error occurred

Usage

- CHKTHRES accesses the automation policy to check the threshold definitions, and the automation status file to check the current error status information of the resource.
- CHKTHRES is used primarily to track error conditions that can be repetitive. By tracking the errors, operators can be notified of the repetitive error situation before it causes problems. SA z/OS tracks a minimal number of situations, such as application abends, SPOOL shortages, and problems causing full LOGREC conditions. It only tracks specific error messages when there are threshold definitions for the related minor resource, *subsystem.msgid*, and when commands are defined for those error messages.
- If no thresholds are defined for the resource itself, CHKTHRES searches in a predefined sequence to find the appropriate default threshold definitions. The

search sequence depends on whether the resource name specifies a major resource such as TSO or a minor resource such as TSO.IKT010D, and on the specified resource type.

For major resources of type SUBSYSTEM, the default threshold definitions for applications or the system apply.

For major resources of type MVSESA, the default threshold definitions for MVS components or the system apply.

For major resources of any other type, only the default threshold definitions for the system apply. When searching for default threshold definitions for minor resources of any type, the resource name is consecutively truncated up to the first two name qualifiers. For example, if no thresholds are defined for the minor resource CICS.TRAN.APPL1, defined thresholds for the truncated resource name CICS.TRAN are checked.

For compatibility with former SA z/OS releases, default threshold definitions to MVS components also apply for the following minor resources:

- MVSESA.MVSDUMP
- MVSESA.SMFDUMP
- MVSESA.LOGREC
- MVSESA.SYSLOG

Example

This example shows the relationship between a CHKTHRES call in an automation procedure and thresholds defined in the automation policy database. The example involves thresholds set for the TSO subsystem. The automation procedure checks the thresholds by calling CHKTHRES.

The thresholds are defined in the automation policy database on the Thresholds Definition panel for the TSO subsystem, as shown in Figure 4.

COMMANDS	HELP

AOFGDYNA	Thresholds Definition
Command ==>>	Scroll ==>> PAGE
Entry Type : Application	PolicyDB Name : DATABASE_NAME
Entry Name : TSO	Enterprise Name : YOUR_ENTERPRISE
Resource : TSO	
Critical Number 8	(1 to 50)
Critical Interval 02:00	(hh:mm or hhmm, 00:01 to 24:00)
Frequent Number 4	(1 to 50)
Frequent Interval 04:00	(hh:mm or hhmm, 00:01 to 24:00)
Infrequent Number 4	(1 to 50)
Infrequent Interval 08:00	(hh:mm or hhmm, 00:01 to 24:00)

Figure 4. Thresholds Definition Panel for TSO Subsystem

The automation procedure to call CHKTHRES is:

```
/* REXX CLIST to check thresholds when a TSO error occurs          */
/* Check whether automation allowed and set TGLOBALs              */
'AOCQRY ...'
:
'CHKTHRES TSO,SUBSYSTEM,NEW'
Select
  When rc = 0 Then Do
```

CHKTHRES

```
/* perform actions required if no thresholds are exceeded */
:
End
When rc = 1 Then Do
/* perform actions required if infrequent thresholds are exceeded */
:
End
When rc = 2 Then Do
/* perform actions required if frequent thresholds are exceeded */
:
End
When rc = 3 Then Do
/* perform actions required if critical thresholds are exceeded. */
:
End
Otherwise Do
/* otherwise, an error occurred, RC=4/5, log error message */
:
End
End
Exit
```

In this example, the threshold settings for TSO in the automation policy database define:

- A critical threshold as 8 errors occurring in 2 hours
- A frequent threshold as 4 errors in 4 hours
- An infrequent threshold as 4 errors in 8 hours

The example automation procedure performs the following processing steps:

1. The automation procedure calls CHKTHRES using a *resource_name* value of TSO, a *resource_type* value of SUBSYSTEM, and the NEW keyword.
2. The time stamp when the error occurred is added to the automation status file, and the thresholds are checked.
3. Upon return to the automation procedure, the rc special variable is checked. If the value indicates a critical threshold is exceeded, the automation procedure should stop recovery to be consistent with the message issued by CHKTHRES.

INGCNTL

Purpose

The INGCNTL command is used to enable and disable alerting to System Automation for Integrated Operations Management (SA IOM) and to set the parameters that are required for the connection to the SA IOM server.

Syntax

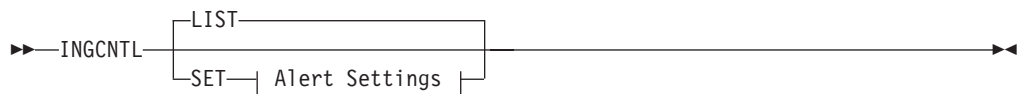

Alert Settings:

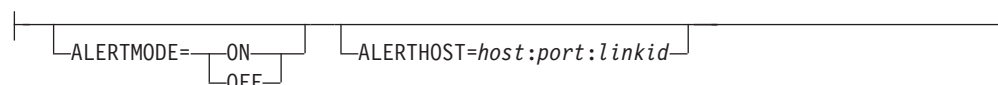

Parameters

LIST This lists all of the supported settings. This is the default.

SET This allows you overwrite one or more settings.

ALERTMODE

This sets the alerting mode:

ON Enables alerting.

OFF Disables alerting.

ALERTHOST

This sets the properties of the connection to the SA IOM server.

host Host name or IP address of the SA IOM server to be used for the notification.

port Port of the SA IOM server to be used for the notification.

linkid Is the link ID to be used for the connection to the SA IOM server.

Note that omitting the colon separators restores the original settings for the connection.

Return Codes

0 Normal completion. Settings have been applied.

4 Invalid parameters were specified.

8 Command failed.

Usage

INGCNTL behaves like an operator command. The output from INGCNTL LIST command takes the form of a correlated multiline message ING149I.

The first line of the multiline message is a header text. Output of the settings begins on line two. Each setting is in a separate line and in the format keyword: value.

Use INGCNTL in a PIPE to capture and analyze (or suppress) the generated message or as an operator NCCF command.

Examples

To list the current settings specify:

```
INGCNTL LIST
```

The output produced is similar to the following:

```
ING149I LIST CONTROL SETTINGS
      ALERTMODE: OFF
```

Note that unset values that have no defaults are not listed.

To enable alerting specify:

```
INGCNTL SET ALERTMODE=ON
```

To set the connection properties specify, for example:

```
INGCNTL SET ALERTHOST=MYIOMSRVR:4711:SA2IOM
```

INGCNTL

To set the connection properties using an IP address specify, for example:
INGCNTL SET ALERTHOST=10.0.0.3:4711:SA2IOM

Note: You can invalidate the ALERTHOST settings for an instance by removing the colons. This makes it easy to restore to the original settings.

INGPOST

Purpose

The INGPOST command posts status notifications to SA z/OS's NMC-based user interface.

Syntax

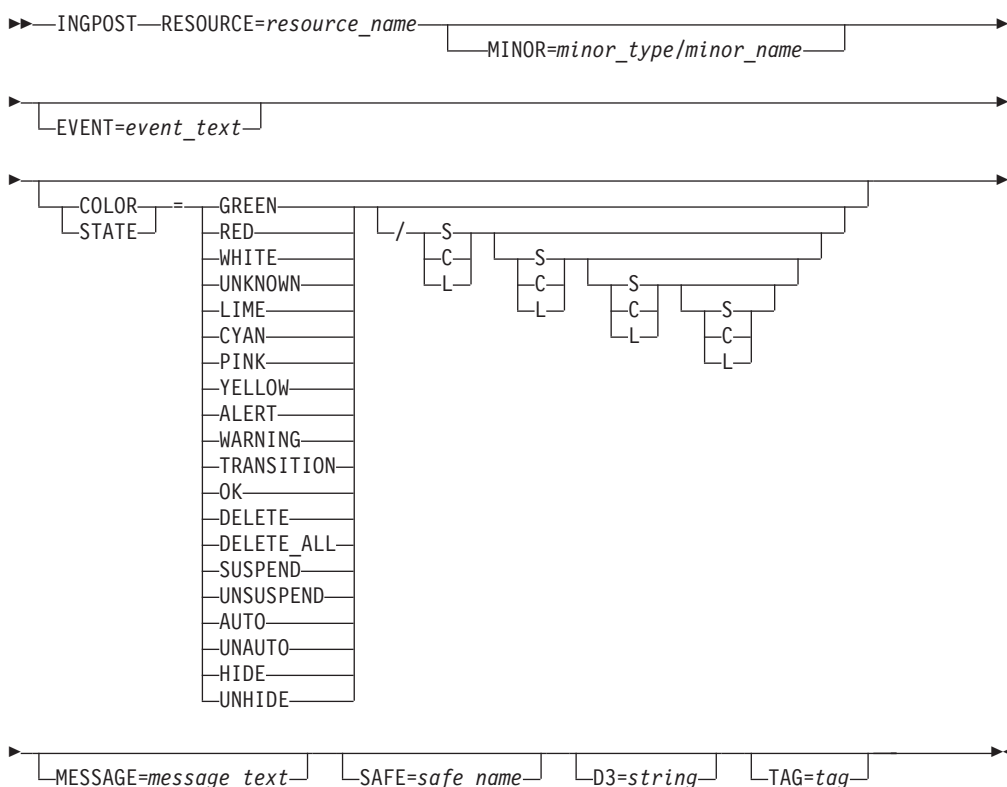

Parameters

RESOURCE

Specifies the name of the major resource that the notification is associated with.

resource_name

Is a standard SA z/OS resource name. The format is either *name/type* or *name/type<</system>>*.

Note that there are a number of special resources that act as anchors for dynamic objects created by INGPOST. The format of an anchor *resource_name* is ANCHOR/MJR/NameOfAnchor.

MINOR

Specifies the minor resource name associated with the notification

minor_name

This is, more or less, a free-form field for specifying the minor resource name. The value must be valid as part of a RODM object name and may have requirements placed upon it by your BLDVIEWS implementation.

If not specified, the minor resource name defaults to null.

EVENT

Specifies a short 'status' value that is appended to the resource's DisplayResourceName.

event_text

Is a single word that will be folded to upper case and appended to the DisplayResourceName for the corresponding RODM object. It should be informative and short.

If not specified the event text will be null and only the resource name and the minor resource name will be present in the DisplayResourceName.

COLOR

Specifies the new DisplayStatus to be posted for the object within RODM.

GREEN or 129 or OK

Sets the object's DisplayStatus to Satisfactory

LIME or 144

Sets the object's DisplayStatus to Medium Satisfactory

CYAN or 145

Sets the object's DisplayStatus to Low Satisfactory

WHITE or 131 or TRANSITION

Sets the object's display status to Intermediate

YELLOW or 161 or WARNING

Sets the object's DisplayStatus to Low Unsatisfactory

PINK or 160

Sets the object's DisplayStatus to Medium Unsatisfactory

RED or 130 or ALERT

Sets the object's DisplayStatus to Unsatisfactory

UNKNOWN or 132

Sets the object's DisplayStatus to Unknown

Note that the syntax diagram does not show the numeric values for the statuses. However, they are accepted and processed correctly.

There are some special values that trigger different processing.

DELETE

Can only be used against a minor resource. It will delete a single minor resource object that is associated with the major resource.

DELETE_ALL

Should be used with a major resource and deletes all minor resource objects associated with that major resource.

SUSPEND and UNSUSPEND

Changes the setting of the 'suspended from aggregation' part of the object.

AUTO and UNAUTO

Changes the setting of the 'automation in progress' part of the object.

HIDE and UNHIDE

Changes the setting of the 'excluded from exception views' part of the object.

The second part of the value is a set of up to 4 SCL flags. The first set applies to the 'operator marked' part, the second to the 'automation in progress' part, the third to the 'suspended from aggregation' part and the fourth to the 'exclude from exception views' part. The following are valid flags:

- S** Sets the bit
- C** Clears the bit
- L** Leaves the bit unchanged

These flags reduce the number of updates needed to perform a status change. Typically, when a resource changes from, for example, Awaiting Automation to Automation In Progress, you need to:

1. Change its color and status
2. Clear its 'operator marked' bit
3. Set its 'automation in process' bit

With these bits, the update can be done with one single call, posting the status as 144/CS. Without these flags this would require three separate calls. When the resource status changes from Automation In Progress to Satisfactory or Degraded, one would post statuses of GREEN/LC or WHITE/LC.

MESSAGE

Specifies a message to be shipped with the status update. It ends up in the DisplayResourceOtherData field.

message_text

This is the text of the message.

The maximum text length is 140 characters.

If it is not specified, and if a message is available from the safe, that message will be used.

SAFE

This specifies the name of the safe that holds the message that the default message text is to be taken from.

safe_name

This is the name of the safe.

If not specified the default safe (called *) will be used.

If the safe is empty, the default message text is null.

D3

When specified this populates the Data3 field on NMC with the given string.

string

This is the string that populates the Data3 field.

TAG

This can be specified when posting a minor resource against a major resource.

tag

This is the tag that is attached to the object in RODM (as an index). The same tag value can subsequently be used to restrict the scope of a

STATUS=DELETE_ALL call for the major resource, so that it will only delete all attached minor resources with the same major resource.

INGQRY

Purpose

The INGQRY common routine returns the value of the specified attribute for a particular resource.

Syntax

```
►►—Value=—INGQRY(res_name,attribute [ ,VERBOSE=NO ] [ ,VERBOSE=YES ] )—►►
```

Parameters

res_name

The name of the resource. This value can be a subsystem name or job name. The search sequence is:

1. Subsystem name
2. Job name

attribute

The name of the attribute. It is one of the following (note that, for different resources, not all of these may be available):

APPL

Returns the subsystem name of the resource. This assumes that the specified resource name is a job name.

ASID

Returns the address space ID of the resource.

CATEGORY

Returns the resource category.

CMDPFX

Returns the command prefix of the resource.

FILE

Returns the file information that represents the resource.

JOB

Returns the job name of the resource.

JOBTYPE

Returns the job type of the resource (MVS, NONMVS or TRANSIENT).

OPER

Returns the work operator that is associated with the resource.

OWNER

Returns the owner information of the resource.

PARENT

Returns the parent information for the resource. Parent information is derived from the HasParent relationship that has a sequence number assigned to it.

INGQRY

PATH

Returns the information about what UNIX process the resource represents.

PID

Returns the USS Process ID (PID) that is associated with the resource.

PORT

Returns the TCPIP port that is represented by the resource.

PROCESS

Contains START or STOP if the resource is in the startup or shutdown phase.

STAT

Returns the agent status of the resource.

SUBCAT

Returns the subcategory of the resource.

SUBID

Returns the MVS subsystem identifier of the resource.

USER

Returns the USS user ID that is associated with the resource.

WLMNAME

Returns the WLM resource name that is associated with the resource.

WTOR

Returns the outstanding reply IDs.

A null value is returned if an unknown subsystem name, job name or variable name is given, or a syntax error is encountered.

VERBOSE

NO

This is the default. The returned value is null.

YES

Causes an error message to be issued if an unknown subsystem name, job name or variable name is given, or a syntax error encountered.

Usage

INGQRY can only be used in the REXX environment.

Examples

The following example obtains the status of resource TSO:

```
stat = INGQRY('TSO','STAT')
```

The following example obtains the subcategory of resource TDBDB001:

```
resname = 'TDBDB001'  
subcat = INGQRY(resname,'SUBCAT')
```

INGRCLUP

Purpose

The INGRCLUP common routine is used to cancel address spaces that may be left over by a resource that did not properly shut down. Multiple address spaces with the same name can be canceled.

Syntax

```
▶▶—INGRCLUP—jobname—▶▶
```

Parameters

jobname

The job name of the address space(s) that must be canceled.

Restrictions and Limitations

The specified parameter cannot be the job name of an SA z/OS managed resource.

Primarily INGRCLUP is meant to be called from within the automation policy (that is, the SHUTINIT command). If you want to call the INGRCLUP common routine from within an automation procedure you have to call AOCQRY before any INGRCLUP call.

Return Codes

0 Processing was successful.

4 Parameters are invalid.

INGRTCMD

Purpose

The INGRTCMD command can be used as a second level NMC command exit for issuing commands from NMC. It takes an object ID and a command string and substitutes object parameters into the command string before routing it to the appropriate system for execution.

Syntax

```
▶▶—INGRTCMD—object_id—cmd_string—▶▶
```

Parameters

object_id

Is the RODM object ID that the command should be issued against. It is used to determine the substitution parameters as well as the target sysplex for the command. The command is sent to the system within the target sysplex that the currently received heartbeats and status change notifications originate from.

cmd_string

Is the command to be issued. It may include substitution tokens.

INGUSS

Purpose

The INGUSS command allows an automation procedure to send commands to z/OS UNIX System Services.

Syntax

```

▶▶—INGUSS—JOBNAME=INGCUNIX—JOBNAME=jobname—FDOPEN=NO—FDOPEN=YES—STDIN=pathin—STDOUT=pathout—▶▶
▶—STDERR=patherr—UNIX_command—<arguments>—<redirection>—▶▶

```

Parameters

JOBNAME=*jobname*

This is the MVS job name used for the newly created address space that runs the specified command. If you do not specify a job name, INGCUNIX is the default.

FDOPEN

This parameter is used to determine whether INGUSS opens STDIN, STDOUT and STDERR before invoking the specified UNIX command.

NO (DEFAULT)

STDIN, STDOUT and STDERR are not opened.

YES

STDIN, STDOUT and STDERR are assigned to /dev/console and opened.

STDIN

This parameter is used to specify a path for STDIN.

If STDIN is specified, FDOPEN=NO is ignored, and STDOUT and STDERR are assigned to /dev/console, unless otherwise specified.

pathin

The path name to be assigned to STDIN.

STDOUT

This parameter is used to specify a path for STDOUT.

If STDOUT is specified, FDOPEN=NO is ignored, and STDIN and STDERR are assigned to /dev/console, unless otherwise specified.

pathout

The path name to be assigned to STDOUT.

STDERR

This parameter is used to specify a path for STDERR.

If STDERR is specified, FDOPEN=NO is ignored, and STDIN and STDOUT are assigned to /dev/console, unless otherwise specified.

patherr

The path name to be assigned to STDERR.

UNIX_command

This is the z/OS UNIX command that is issued under the user ID of the resource this command belongs to. It is not possible to issue commands for other user IDs. It can be any z/OS UNIX command or the name of a shell script (both fully qualified). The resource that issues this command must have an application type USS.

Restrictions and Limitations

The INGUSS command can be called only by another automation procedure or by a command processor. The common routine AOCQRY must be invoked first to set the necessary task global variables.

Note: The INGUSS command can only be used if the primary JES is available. Therefore, z/OS UNIX resources using INGUSS need a HASPARENT dependency to JES. Most of all z/OS UNIX applications have this dependency. If you want to issue prestart commands, an additional PREPAVAILABLE dependency is necessary. This is because SA z/OS does not create an address space without JES.

Usage

The following variables can be used to obtain data of the resource, if INGUSS is issued from the automation policy:

&SUBSPATH

The path statement of the resource. The resource must be a process.

&SUBSFILE

The filename of the resource. The resource must be a file.

&SUBSPID

The ID for the USS process. See also %PID% below. &SUBSPID is the process id returned from the host service BPX1SPN while %PID% is the process ID returned from the USS call getpsent().

IBM recommends the use of &SUBSPID in preference to %PID% as problems can arise retrieving the pid in an environment where there are multiple uid 0 users active.

&SUBSPORT

The port number of the resource. The resource must be a port.

&SUBSUSSJOB

The job name assigned to a process. The resource must be a process.

&SUBSAPPL

The application name.

&SUBSASID

The address space ID of the address space the process runs in. The resource must be a process.

The information for &SUBSUSSJOB and &SUBSASID is refreshed with each monitoring cycle. If a process forks and gets a new job name (normally a digit is appended at the end of the original job name), SA z/OS will detect the new job name after the next scheduled monitoring. This works only if SA z/OS internal process monitoring is used.

When the resource becomes inactive, the values of &SUBSUSSJOB and &SUBSASID are cleared.

In addition, for process resources %PID% can be used to get the PID of a process. The command `INGUSS /bin/kill %PID%` results in determining the PID of the process defined by the path of the resource and replacing %PID% by the real value of the process ID.

When issuing a command, SA z/OS switches to the user's home directory and sets the following environment variables for the user that the resource belongs to:

- HOME
- USER
- SHELL

The login shell uses these environment variables to detect which UNIX profiles to execute. If the started program should get the whole environment of the user as if this user was logged on, you must use a login shell as the start command.

Recommendation:

When using INGUSS to start applications, IBM recommends that you use the JOBNAME parameter in order to get a unique job name. For example:

```
INGUSS JOBNAME=&SUBSJOB UNIX_start_command
```

Otherwise, all applications started by SA z/OS without this parameter will have the same job name of INGCUNIX (if the application itself does not change the job name).

If the job name is not unique, specify job type MVS.

Examples

1. To start inetd through a login shell, issue the following command:

```
INGUSS JOBNAME=INETD /bin/sh -L -c '/usr/sbin/inetd /etc/inetd.conf'
```

where:

JOBNAME=INETD

This is optional, it assigns the MVS job name 'INETD' to the started process.

/bin/sh

The shell.

-L The option for the login shell.

-c The option to the shell to execute the following command.

'/usr/sbin/inetd /etc/inetd.conf'

This is the command that is executed by the login shell

2. To start inetd through a login shell, issue the following command:

```
INGUSS JOBNAME=INETD /bin/sh -L -c '/usr/sbin/inetd /etc/inetd.conf
>/tmp/inetd.out 2>/tmp/inetd.err'
```

where:

>/tmp/inetd.out

This redirects the command output to /tmp/inetd.out rather than /dev/null.

2>/tmp/inetd.err

This redirects the error output to /tmp/inetd.err rather than /dev/null.

3. To start cron through a login shell, issue the following command:

```
INGUSS JOBNAME=CRON /bin/sh -L -c '/usr/sbin/cron </tmp/cron.in
>/tmp/cron.out 2>/tmp/cron.err'
```

where:

</tmp/cron.in

This redirects the command input to /tmp/cron.in rather than /dev/null.

>/tmp/cron.out

This redirects the command output to /tmp/cron.out rather than /dev/null.

2>/tmp/cron.err

This redirects the error output to /tmp/cron.err rather than /dev/null.

In the example above the redirection is necessary. If not specified, cron will not hold the pid lock file, and thus multiple pid processes could be started.

INGVSTRT

Purpose

The INGVSTRT common routine allows an automation procedure to start a virtual operator station task (VOST).

Syntax

►►—INGVSTRT—| mode |—*command*—►►

mode:

| [SYNC, |
| [ASYNC, |

Parameters

mode This is a positional parameter that defines the mode that *command* operates in. It is required only if *command* starts with SYNC or ASYNC. It clarifies whether *command* operates synchronously (the default) or asynchronously (it terminates but leaves the VOST active).

It has the following values, which must be followed by a comma:

SYNC Use SYNC as a *positional parameter* if *command* operates synchronously and it starts with SYNC or ASYNC. This is the default.

ASYNC

Use ASYNC if *command* operates asynchronously, that is, it terminates and leaves the VOST active. This prevents message ING156I from being issued.

command

The command, including all parameters, to be executed in the VOST. Note that this can also be a REXX CLIST.

Restrictions and Limitations

The INGVSTRT command can be called only by another automation procedure or by a command processor. The AOCQRY common routine must be invoked first to

INGVSTRT

set the necessary task global variables. In particular, the SUBSJOB variable must be set. Its content is used as the attach name of the VOST.

The ATTACH command is used to start the VOST and therefore the restrictions of the attach command apply to the command specified on INGVSTRT.

Return Codes

- 0 VOST started successfully.
- 4 Invalid parameters were specified.
- 6 Environment check failed.
- 8 ATTACH command failed.

Messages

The following messages are issued by INGVSTRT:

```
AOF010I WRONG NUMBER OF PARAMETERS ENTERED
ING151I ATTACH OF name SUCESSFUL
ING152I ATTACH OF name FAILED WITH RC=rc
ING155I ENVIRONMENT CHECK FAILED FOR command. REASON=rs
```

Usage

Use INGVSTRT as the start command of a NONMVS type APL.

Consider using INGVSTOP as a stop command and INGVMON as a monitor routine (see "INGVSTOP" and "INGVMON" on page 99).

Examples

To start CLIST myclist in a VOST, create a NONMVS type APL and enter the following as a start command:

```
INGVSTRT MYCLIST PARM1,2nd,Third
```

Note that parameters can be in mixed case.

INGVSTOP

Purpose

The INGVSTOP common routine allows an automation procedure to stop a virtual operator station task (VOST).

Syntax



Parameters

DETACH

Specifies that the VOST is to be stopped with the DETACH command.

FORCE

Specifies that the VOST is to be stopped with the STOP FORCE command.

TASK Specifies that the VOST is to be stopped with the STOP TASK command.

IMMED

Specifies that the VOST is to be stopped with the STOP IMMED command.

UNCOND

Specifies that the VOST is to be stopped with the STOP UNCOND command.

Restrictions and Limitations

The INGVSTOP command can be called only by another automation procedure or by a command processor. The AOCQRY common routine must be invoked first to set the necessary task global variables. In particular, the SUBSJOB variable must be set. Its content is used as the attach name of the VOST.

Note that the VOST may be still active for a certain time after INGVSTOP has ended with RC=0.

Return Codes

0 Stopping of the VOST was initiated successfully.

4 Invalid parameters were specified.

6 Environment check failed.

8 DETACH or STOP command failed.

Messages

The following messages are issued by INGVSTOP:

```
AOF010I WRONG NUMBER OF PARAMETERS ENTERED
ING153I command OF name SUCCESSFUL
ING154I command OF name FAILED WITH RC=rc
ING155I ENVIRONMENT CHECK FAILED FOR command. REASON=rs
```

Usage

Use INGVSTOP as a stop command of a NONMVS type APL.

Consider using INGVSTRT as a start command and INGVMON as a monitor routine (see "INGVSTRT" on page 87 and "INGVMON" on page 99).

Note: It is not recommended to use STOP IMMED because the target task may lose storage or other resources.

You are strongly urged never to use STOP UNCOND because it destroys important task control information in NetView. You might not be able to restart NetView until the next IPL of MVS.

Examples

To stop a VOST using the DETACH command, enter the following as a stop command in the VOST management APL:

```
INGVSTOP DETACH
```

MDFYSHUT

Purpose

MDFYSHUT sets the AOFSHUTMOD task global variable to whatever value is contained in the MDFYSHUT parameter string. The AOFSHUTMOD value is then used by the shutdown program.

MDFYSHUT also provides support for a SUSPEND function.

Syntax

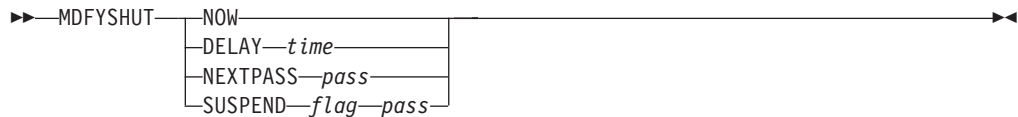

Parameters

NOW

The next shutdown pass will occur as soon as possible.

DELAY

The next shutdown pass will occur after *time* instead of the shut delay defined for the subsystem. Note that there is no validation of the time. If you set an invalid value the shutdown may abend.

NEXTPASS

The next shutdown pass that will be processed (after the subsystem shut delay) will be *pass*, not the current pass plus one.

SUSPEND

Determines how the shutdown is suspended, where:

flag

Is the name of a common global variable that is used to determine how the shutdown is suspended. If the flag is set off, the shutdown will be stopped and the flag will be checked again on the next pass. If the flag is set on the shutdown will continue, that is, it is no longer suspended.

pass

Is the number of the pass that the MDFYSHUT SUSPEND command is coded on. It must be included so that MDFYSHUT can return to this pass and recheck the flag.

Restrictions and Limitations

MDFYSHUT can be used on any pass of the shutdown.

The routine containing MDFYSHUT must run on the default task, that is, leave the task field blank.

The routine containing MDFYSHUT cannot be rescheduled with a CMD LOW.

Task Global Variables

AOFSHUTMOD is a task global variable that is set by the MDFYSHUT command during the shutdown process. Its value affects the subsequent flow of the shutdown process. Possible values are any parameter string for the MDFYSHUT command except for suspend.

MDFYSHUT

Chapter 3. Monitoring Routines

SA z/OS offers several routines that can be used to monitor various aspects of your enterprise.

SA z/OS expects certain return codes from all monitor routines, either from SA z/OS-provided ones or from your own routines. These can be one of the following:

Return Code	Meaning
0	Active
4	Starting
8	Inactive
12	Error

For more details refer to the chapter "How to Monitor Applications" in *IBM Tivoli System Automation for z/OS Customizing and Programming*.

Note: All the monitoring routines that are described in this chapter

AOFADMON

Purpose

The AOFADMON routine is used to determine the status of a job within the operating system using the MVS D A method.

Note: For performance reasons it is recommended that you use INGPJMON instead of AOFADMON.

Syntax

▶▶—AOFADMON—*jobname*—————▶▶

Parameters

jobname

The job name that the operating system knows the associated application by.

Restrictions and Limitations

None.

Return Codes

- 0 The job is active.
- 4 The job is starting.
- 8 The job is inactive.
- 12 Parameter error.

AOFAPMON

Purpose

The AOFAPMON routine is used to determine the status of a PPI receiver. It calls DISPPI and checks if a specific PPI receiver is active.

Syntax

▶▶—AOFAPMON—*ppiname*————▶▶

Parameters

ppiname

The name of the PPI receiver this routine searches for. When the PPI receiver is active, the system issues return code 0. Otherwise return code 8 is issued.

Restrictions and Limitations

None.

Return Codes

- 0 The resource is active.
- 8 The resource is inactive.

AOFATMON

Purpose

The AOFATMON routine is used to determine the status of a task operating within the NetView environment. When the application is defined using the SA z/OS customization dialogs, the application job name must be defined to be the NetView task name.

Syntax

▶▶—AOFATMON—*taskname*————▶▶

Parameters

taskname

The name of the NetView task whose status is to be obtained. This name is the same as the application job name.

Restrictions and Limitations

None.

Return Codes

- 0 The task is active.
- 4 The task is starting.

- 8 The task is inactive.
- 12 Parameter error.

AOFCPSM

Purpose

The AOFCPSM routine is used to determine the status of processor operations.

Syntax

▶▶—AOFCPSM—*jobname*—————▶▶

Parameters

jobname

The job name that SA z/OS knows the processor operations application by.

Restrictions and Limitations

None.

Return Codes

- 0 The task is active.
- 8 The task is inactive.
- 12 Error.

AOFNCOMON

Purpose

The AOFNCOMON routine is used to determine the status of the NETCONV connection running between the NMC server and z/OS NetView. The connection type can either be a TCPIP or SNA connection. It runs on the related work operator taking care of it.

Syntax

▶▶—AOFNCOMON—*jobname*—————▶▶

Parameters

jobname

The job name that automation knows the associated application as. This can be obtained from the SUBSJOB task global variable that is returned by AOCQRY.

Restrictions and Limitations

None.

AOFNCMON

Return Codes

- 0 The connection is active.
- 8 The corresponding work operator does not hold a connection. The connection is inactive.
- 12 The connection status cannot be determined.

AOFUXMON

Purpose

The AOFUXMON routine is used to determine the status of a resource with application type USS. This resource can either be a z/OS UNIX process, a file in the z/OS UNIX file system (HFS), or a TCP port. Depending on the kind of resource (process, file, or port) AOFUXMON decides which internal monitoring method to use.

Syntax

▶▶—AOFUXMON—*jobname*—————▶▶

Parameters

jobname

The job name that SA z/OS knows the associated USS process, file, or port by.

Restrictions and Limitations

AOFUXMON should only be used as a programming facility because its only output is a return code.

AOFUXMON uses active rather than passive monitoring for ports. Active monitoring will cause a connection to be established to an active port. If this is not desirable then a customer supplied monitoring routine should be used instead of AOFUXMON for port monitoring.

Return Codes

- 0 The resource is active.
- 4 The resource is starting.
- 8 The resource is inactive. Also returned if JES is inactive and SA z/OS is restarting after an IPL.
- 12 JES is inactive and SA z/OS has fully initialized after an IPL.
- 16 One of the following parameter errors occurred:
 - The *jobname* parameter was not specified.
 - The *jobname* parameter does not represent a USS type resource.
 - The *jobname* parameter does not represent a USS PATH, PORT or FILE.
- 20 A return code other than 0, 4 or 8 was returned from the USS INGCCMD routine. Check for related messages or turn on debug for AOFUXMON (this also turns on debug for INGCCMD).

INGPJMON

Purpose

The INGPJMON routine is used to determine the status of a job as known by the operating system. This is *not* the SA z/OS status of the job, which should be determined using AOCQRY.

INGPJMON does the following:

- It optionally returns the jobname and address space ID that match passed criteria
- It allows you to search for all address spaces that match the specified jobname
- It supports optional address-space search criteria

This monitoring routine is the foundation for supporting duplicate job names because standard address space monitoring takes the address space ID associated with the job into account. This allows you to distinguish between multiple occurrences of the same job in the system.

Syntax

```

  >>—INGPJMON—jobname—┌┐┐
                               └┘└┘└┘
                               ,asid ,stem ,options
  <<<
  
```

Note: All parameters are positional and must be replaced by a comma if omitted and followed by another operand.

Parameters

jobname

This is the name of the job to be searched for. An asterisk (*) must be specified as a placeholder if no job name is given.

asid

This is the address space ID (in hex) associated with the job. If omitted, the INGPJMON routine returns the first address space that matches the job name.

stem

This is the name of a NetView task global stem variable that will contain the job name and ASID of the address space that has been found.

The parameter is optional. If a task global name is specified, the following data are returned separated by a comma:

1. Job name.
2. Address space ID. If more than one ASID are returned, they are separated by a blank.

options

These are additional options, as follows:

***ALL**

Causes the monitoring routine to return all ASIDs that match the specified job name.

INGPJMON

*TRACE

Causes the monitoring routine to trace its processing by means of the component trace.

The following example shows how to retrieve data via a NetView task global stem:

```
'INGPJMON WEBSERVER,,STEM01,*ALL'  
'GLOBALV GETT STEM01.0 STEM01.1'  
exit 0
```

After executing the sample REXX the following data will be returned:

```
stem01.0 = 1  
stem01.1 = WEBSERVER,0028 0033 0045,
```

In this example WEBSERVER is running in three address spaces.

A maximum of 48 ASIDs can be returned in each stem variable due to the NetView restriction of 256 bytes per variable. If more than 48 ASIDs are returned then additional ASIDs will be returned in additional stem variables. The last ASID is terminated by a comma.

Restrictions and Limitations

None.

Return Codes

- 0 The job is active.
- 4 The job is starting.
- 8 The job is inactive.
- 12 Parameter error.

INGPSMON

Purpose

The INGPSMON routine is used to determine the status of an MVS subsystem. Unlike INGPJMON it does not search MVS address space control blocks.

Syntax

```
►►—INGPSMON—jobname—┐ ┐  
└─┘,varname └─┘,options ─►
```

Parameters

jobname

This is the job name that is assigned to the subsystem. The job name must be identical to the MVS subsystem name. Specify !PRI for the primary subsystem.

varname

This is the name of a NetView task global stem variable that will contain information about the MVS subsystem.

options

These are additional options, as follows:

***TRACE**

Causes the monitoring routine to trace its processing by means of the MVS component trace function.

Restrictions and Limitations

None.

Return Codes

- 0 The job is active.
- 4 The job is starting.
- 8 The job is inactive.
- 12 Parameter error.

INGVMON**Purpose**

The INGVMON routine is used to determine the status of a virtual operator station task (VOST). It should be used as monitoring routine in a VOST management APL.

Syntax

▶▶—INGVMON—*jobname*—————▶▶

Parameters

jobname

Specifies the job name that SA z/OS knows the associated VOST management APL as. This can be obtained from the SUBSJOB task global variable returned by AOCQRY.

Restrictions and Limitations

INGVMON should only be used as a programming facility because its only output is a return code.

Return Codes

- 0 The VOST is ACTIVE.
- 8 The VOST is INACTIVE.
- 12 Monitoring failed.
- 16 One of the following parameter errors occurred:
 - The *jobname* parameter was not specified.
 - The *jobname* parameter is not a valid job name.

ISQMTSYS

Purpose

The ISQMTSYS routine monitors processor operations target system resources. It is used to verify the availability of a target system according to a timer defined by the user.

Syntax

▶▶—ISQMTSYS—*jobname*————▶▶

Parameters

jobname

The job name that SA z/OS knows the processor operations target system by.

Restrictions and Limitations

None.

Return Codes

- 0 The target system is active.
- 4 The target system is starting.
- 8 The target system is inactive.
- 12 The resource could not be found.

Chapter 4. Generic Routines

Generic routines are routines that are complete in their own right. They can be called from the NetView automation table, from timers, or from other automation procedures.

This chapter explains how to use the generic routines that perform a single, specialized function.

The routines described here may be used while automating any SA z/OS application. In the context of SA z/OS, an *application* is defined as:

- An MVS subsystem
- An MVS job
- A non-MVS resource, that is, a resource that is not a z/OS address space, or that does not respond to the usual MVS startup and shutdown commands
- Your own applications

Occasionally, you may see the term *subsystem* used to refer to applications in general.

Using SA z/OS Generic Routines for Programming

Using common and generic routines in automation procedures provides you with the following advantages:

- Reduced development time, because less code has to be written.
- Portable code, because automation policy information unique to an enterprise can be kept in the automation control file rather than distributed among many automation procedures. The automation procedures implement a number of different rules for handling a situation and the automation control file is used to select which rules are applicable to the current situation.
- A consistent, documented interface.
- Normally, these routines are invoked directly from the NetView automation table but they can also be called from automation procedures.

Refer to Part 2, “SA z/OS System Operations Routines,” on page 5 for further information on how to use common routines in automation procedures.

ACTIVMSG

Purpose

You can use the ACTIVMSG generic routine to respond to ACTIVE and UP messages from an application by changing the SA z/OS status of the application. ACTIVMSG calls the ISSUEACT generic routine to also issue commands and replies that are defined in the automation policy for both the ID of the ACTIVE or UP message and for the new status of the application. Typically, ACTIVMSG is called from the NetView automation table.

Syntax

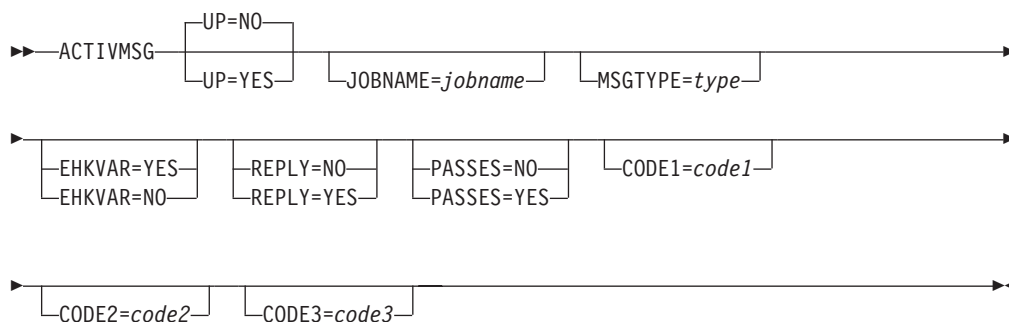

Parameters

UP

This parameter is used to distinguish between ACTIVE messages and UP messages. ACTIVE messages indicate that the job associated with an application is working but is not yet available for use. UP messages indicate that the job associated with an application is available for use.

NO

NO should be used if you are responding to an application ACTIVE message. The application is placed in ACTIVE status if it is not there already. UP=NO is the default.

YES

YES should be used if you are responding to an application UP message. The application is placed in UP status if it is not there already. If the application is a transient job then it is placed in RUNNING status.

JOBNAME

The name of the job that the message is for. If not specified, the job name is taken from the message's job name field. You must supply a value for the job name if you are calling ACTIVMSG from a CLIST.

MSGTYPE

This parameter is used to search for command and reply entries to *subsystem/msgtype*-pairs in the automation control file, where *subsystem* is the subsystem name derived from the job name.

When a match occurs, the commands that are associated with the entries are issued. This is in addition to the entries that are associated with the ENTRY-TYPE pair *subsystem/ACTIVE* if UP=NO and *subsystem/UP* if UP=YES.

If parameter MSGTYPE is not specified, the message identifier of the message that ACTIVMSG is called for is taken as the default.

EHKVAR

This parameter determines whether the tokens of the parsed message text are to be stored in task global variables EHKVAR0 through EHKVAR9 and EHKVART.

YES

The tokens of the triggering message are to be assigned to the task global variables EHKVAR*n*.

NO

No values are to be assigned to the task global variables EHKVAR n .

REPLY

This parameter determines whether a defined reply is issued for a message that ACTIVMSG has been called for.

YES

A defined reply in the automation policy for the message that is being handled by ACTIVMSG is issued. REPLY=YES is assumed as the default if the message is a WTOR, otherwise the default is REPLY=NO.

NO

A defined reply for a WTOR that is being handled by ACTIVMSG is not issued.

PASSES

Specifies whether passes are used to issue commands or replies (or both) that have been defined in the automation policy.

YES

PASSES=YES is passed to the ISSUEACT generic routine.

NO

PASSES=NO is passed to the ISSUEACT generic routine.

CODE1=code1 CODE2=code2 CODE3=code3

These parameters are passed to the ISSUEACT generic routine, where they are used to select defined commands and replies via code entries.

Restrictions and Limitations

- If ACTIVMSG is driven by a delete operator message, no action is taken in response to this message.
- Defined commands and replies are only issued in response to a message or a status change if the start flag of the related minor resources of the application allows automation.

Usage

It is recommended that you use ACTIVMSG for all IEF403I (job started) messages.

If ACTIVMSG is called for a WTOR and it is not replied to, OUTREP is called to track the WTOR.

If you are invoking ACTIVMSG for a generic message you should use the ING\$QRY NetView automation table function to screen the message before invoking ACTIVMSG. See Chapter 6, "ING\$QRY NetView Automation Table Function," on page 167 for more information.

ACTIVMSG should run on the working operator of the subsystem that issued the message. Otherwise, the ACTIVMSG routine will run asynchronously to the calling procedure. This means that when the calling procedure regains control, the status of the affected subsystem may not yet have changed.

All commands and replies that are triggered through ACTIVMSG have access to the SAFE, called AOFMSAFE, that stores the message that caused the ACTIVMSG call.

Task Global Variables

EHKVAR0 through EHKVAR9 and EHKVART

When defining the commands in the automation control file to be issued by generic routine ACTIVMSG, the variables &EHKVAR0 through &EHKVAR9 and &EHKVART can be used to be substituted by the tokens of the parsed message that has driven ACTIVMSG. &EHKVAR0 will be substituted by the message ID, &EHKVAR1 by the first token of the message text after the message ID, &EHKVAR2 with the second token and so forth. &EHKVART will be substituted by the trailing message text after the 9th token.

Examples

The following example shows how ACTIVMSG is called from the NetView automation table:

```
IF MSGID = 'IEF403I' & TOKEN(2) = SVJOB & DOMAINID = %AOFDOM%
  & ATF('ING$QRY APPL,,JOB='VALUE(SVJOB)) ^= ''
THEN
EXEC(CMD('ACTIVMSG JOBNAME=' SVJOB)
ROUTE(ONE %AOFOPGSSOPER%));
```

AOCFILT

Purpose

This generic routine is used to screen messages which invoke other generic routines. While it adds to the overhead of a useful invocation of a generic routine, it greatly reduces CPU used to detect an unnecessary invocation.

Note: For performance reasons consider using ING\$QRY instead, see Chapter 6, “ING\$QRY NetView Automation Table Function,” on page 167.

Syntax

```
▶▶ AOCFILT jobname command ▶▶
```

└───┬───┘
*

Parameters

jobname

This is the name of the job that the message refers to. If an * is specified then the default job name for the message, retrieved with the NetView Jobname() function, is checked.

command

This command is issued (in a PIPE) if the *jobname* parameter is the name of a job known to SA z/OS. If the job name is not the name of a job of a SA z/OS-controlled application, the command is not issued.

Restrictions and Limitations

- The command should be invoked only when there is a message in the default safe. Normally this will be from the automation table.
- You must obtain the job name before you invoke AOCFILT.

Return Codes

AOCFILT returns a return code of 0.

Usage

The command should be coded in the automation table where you are using a generic message (such as IEF403I) to invoke one of the SA z/OS generic routines (such as ACTIVMSG).

AOCFILT routes the passed command to the autooperator responsible for that particular subsystem.

AOCFILT is not as efficient as explicitly screening for the message in the automation table, but may be more efficient than negative screening. AOCFILT also makes the automation statement more portable, in that you will not have to update it if you define a new application to SA z/OS.

Examples

In the example below, the automation table is used to block out all IEF403I messages concerning jobs starting with the letters BAT, and AOCFILT is used to screen the other IEF403I messages.

```
IF MSGID = 'IEF' . & DOMAINID = %AOFDOM% THEN BEGIN;
...
  IF MSGID = 'IEF403I' THEN BEGIN;

      IF TOKEN(2) = 'BAT' . THEN DISPLAY(N) NETLOG(Y);

      IF TOKEN(2) = SVJOB THEN
        EXEC(CMD('AOCFILT ' SVJOB ' ACTIVMSG JOBNAME=' SVJOB)
          ROUTE(ONE %AOFOPGSSOPER%));
      END;
  ...
  ALWAYS;
END;
```

Related Commands

- “ACTIVMSG” on page 101
- “HALTMSG” on page 110
- “ISSUEACT (ISSUECMD, ISSUEREP)” on page 118
- “TERMMMSG” on page 127

AOFCPMSG

Purpose

The AOFCPMSG generic routine lets you:

- Capture messages and save them in common global variables for subsequent display by DISPINFO
- Add the message to SDF for display in the Messages panels
- Add the message to NMC as a minor resource of the major resource that issued the message

To use the AOFCPMSG routine, add it to your NetView automation table.

Syntax

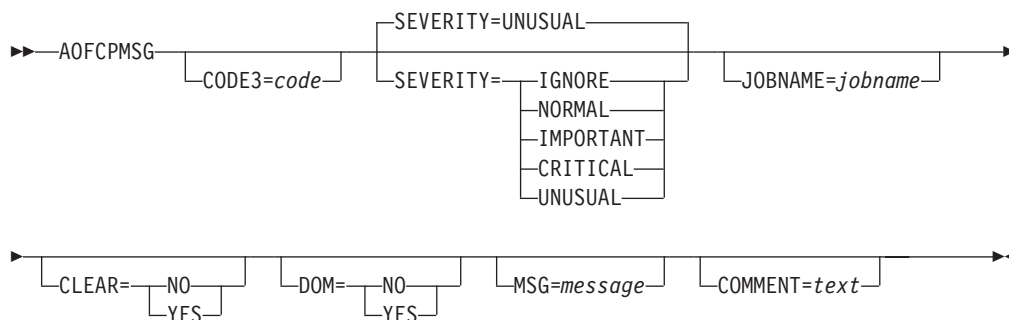

Parameters

CODE3

code

This is the optional CODE3 value used by CDEMATCH to specify the severity of the message.

SEVERITY

This parameter allows you to directly specify a severity and bypass the code matching process. To change the severity classification of a message you need to change the automation table.

The severity is always overwritten by a policy entry. In other words, if a policy entry exists, the severity is taken from there.

The severity of a message can also be specified in a CDEMATCH against the subsystem. If no match is found against the subsystem, a match is attempted against the system issuing the message. The message ID for the code match is CAPMSGS.

CODE1 is set to the message ID of the message being captured. CODE2 is set to the subsystem name of the subsystem that issued the message. CODE3 is set to the value specified in the *code* parameter.

The severity code that is defined as the value to be returned to the command list can be one of the following:

IMPORTANT

The message is captured and its color is set to PINK.

IGNORE

The message is not captured.

NORMAL

The message is captured and its color is set to GREEN.

UNUSUAL

The message is captured and its color is set to YELLOW.

CRITICAL

The message is captured and its color is set to RED.

JOBNAME

The JOBNAME is optional and specifies the job name of the subsystem that issued or is assigned to the message. This parameter overrides the value as determined from the jobname() function against the message.

CLEAR**YES|NO**

Specifies whether the existing messages that are recorded for the subsystem should be erased and SDF and NMC resources should be removed for the subsystem. This may be specified without a message being issued. The default is NO.

DOM**YES|NO**

Specify YES to cause AOFCPMSG to delete a previously captured message instance that matches the current message ID (that is, the message ID passed to AOFCPMSG from the AT, unless overridden by the MSG parameter).

If a match is found then the first instance of this message ID is removed from SDF and NMC and the severity of the deleted message is downgraded to normal in the globals. If the current message has a severity higher than normal, a DOM record is also recorded in the globals.

See the MSG parameter below for details about how to override the message ID that is passed from the AT.

The default is NO unless the message is detected as a DOM, in which case the default is YES.

MSG*message*

Specify a message to override the message that is passed from the AT. This may be an entire message including a message ID followed by message text or just a message ID. This parameter can also be used in conjunction with the DOM parameter to DOM any previously captured message. When used in conjunction with the DOM parameter only a message ID is needed.

The *message* must be delimited with single quotes, double quotes, or parentheses if it contains blanks or special characters.

COMMENT*text*

If specified, this text will be appended to the message for SDF and placed in the DATA3 field for NMC.

The comment text must be delimited with single quotes, double quotes, or parentheses if it contains blanks or special characters.

Restrictions and Limitations

To use the AOFCPMSG command system operations must be initialized. AOFCPMSG should only be executed as an automation table command. Excessive use of AOFCPMSG will reduce NetView storage because messages are stored in common global variables. It is recommended to restrict the use of AOFCPMSG to exception condition messages.

Usage

Add the AOFCPMSG routine to your NetView automation table.

AOFCPMSG can also be called outside of the AT when specifying the MSG parameter.

AOFCPMSG

Examples

The following example shows how AOFCPMSG is called from the NetView automation table to change the severity of message HSAM1050E to CRITICAL:

```
IF MSGID = 'HSAM1050E'  
THEN  
EXEC(CMD('AOFCPMSG SEVERITY=CRITICAL')ROUTE(ONE * %AOFOPGSSOPER%));
```

AOFRCMTR

Purpose

This routine can be used to update the health status of monitor resources by issuing the defined monitor commands for these monitor resources.

Syntax

►► AOFRCMTR *object* jobname

Parameters

object Specifies the object that the monitor resource is associated with.

jobname Specifies the job name that the monitor resource is associated with. If AOFRCMTR is called from the NetView automation table, the issuing job of the automated message is taken as the default value.

FWDMMSG

Purpose

FWDMMSG can be invoked from the NetView automation table to forward messages from a remote system to a focal point system. By defining entries in the remote NetView automation table that invoke FWDMMSG you can:

- Trap messages that you are interested in
- Assign specific message classes to those messages
- Forward the messages to the focal point system

Messages are received by focal point notification operators who are defined to receive messages of the assigned classes.

Syntax

►► FWDMMSG (1)
class SELF MSG=*text*

Notes:

- 1 Up to 10 classes may be specified. Classes should be separated by blanks.

Parameters

class

The message notification classes to be assigned to the message. You should specify at least one message class. If no class is specified, the message is sent to GATOPER's authorized receiver. You can specify up to ten blank-delimited message classes. There are no default message classes defined.

SA z/OS notification classes are described in *IBM Tivoli System Automation for z/OS Messages and Codes*. You can define your own message classes using the Environment Definition panels of the customization dialogs.

Note: The classes you assign here must match those defined using the Operator Notification panels of the customization dialogs.

SELF

If FWDMSG is invoked on a system that does not have a defined focal point, send the message to the appropriate notification operators on the issuing system. If FWDMSG is invoked on a system that does have a defined focal point, SELF is ignored.

MSG

The message text used for this message. If not coded, the messages in the message buffer are used. This parameter is valid for single-line messages only.

Restrictions and Limitations

- A triggering delete operator message will not be forwarded to the focal point.
- Do not use the MSG parameter for multiline messages.
- When FWDMSG is called from the NetView automation table, the message to be processed is in the message buffer. When FWDMSG is called from a command processor or other automation routine, the message text from the MSG= parameter is treated as the entire message to be forwarded, including the message ID.
- If invoked with a pipe, all messages in the pipe will be forwarded to the focal point as separate messages.

Return Codes

- 0 Automation procedure processed correctly.
- 1 Processing error was encountered.

When the MSG parameter is used for a multiline message, the following message is issued:

```
AOF013I SPECIFIED OPERAND MSG= INVALID FOR msgid MLWTO
```

Examples

Example 1

The following example sends individual messages for each line in the multiline response:

```
IF MSGID='IST075I' & DOMAINID = %AOFDOM%
THEN EXEC(CMD('FWDMSG A1')ROUTE(ONE *));
```

Example 2

FWDMSG

The following example sends all RACF® messages to ensure notification of security violations:

```
IF MSGID='ICH' . & DOMAINID = %AOFDOM%  
THEN EXEC(CMD('FWDMSG A2')ROUTE(ONE *));
```

HALTMSG

Purpose

The HALTMSG generic routine can be used to respond to a message by changing the status of an application to HALTED. HALTMSG calls the ISSUEACT generic routine to also issue commands and replies that are defined in the automation policy for the ID of the processed message and for the HALTED status. Typically, HALTMSG is called from the NetView automation table.

Syntax

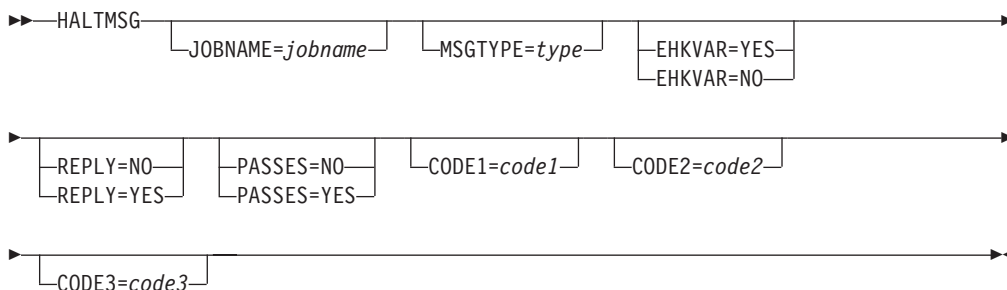

Parameters

JOBNAME

The name of the job that the message is for. If not specified, the job name is taken from the message's job name field. You must supply a value for the job name if you are calling HALTMSG from a CLIST.

MSGTYPE

This parameter is used to search for command and reply entries to *subsystem/msgtype*-pairs in the automation control file, where *subsystem* is the subsystem name derived from the job name.

When a match occurs, the commands that are associated with the entries are issued. This is in addition to the command entries that are associated with the ENTRY-TYPE pair *subsystem/HALTED*.

If parameter MSGTYPE is not specified, the message identifier of the message that HALTMSG is called for is taken as the default.

EHKVAR

This parameter determines whether the tokens of the parsed message text are to be stored in task global variables EHKVAR0 through EHKVAR9 and EHKVART.

YES

The tokens of the triggering message are to be assigned to the task global variables EHKVAR*n*.

NO

No values are to be assigned to the task global variables EHKVAR*n*.

REPLY

This parameter determines whether a defined reply is issued for a message that HALTMSG has been called for.

YES

A defined reply in the automation policy for the message that is being handled by HALTMSG is issued. REPLY=YES is assumed as the default if the message is a WTOR, otherwise the default is REPLY=NO.

NO

A defined reply for a WTOR being handled by HALTMSG is not issued.

PASSES

Specifies whether passes are used to issue commands or replies (or both) that have been defined in the automation policy.

YES

PASSES=YES is passed to the ISSUEACT generic routine.

NO

PASSES=NO is passed to the ISSUEACT generic routine.

CODE1=code1 CODE2=code2 CODE3=code3

These parameters are passed to the ISSUEACT generic routine, where they are used to select defined commands and replies via code entries.

Restrictions and Limitations

- If HALTMSG is driven by a delete operator message, no action is taken in response to this message.
- HALTMSG will not affect an application that is being shut down.
- HALTMSG will not affect an application that is not in UP status.
- The application status is updated and the relevant commands are issued each time HALTMSG is run.
- Defined commands and replies are only issued in response to a message or a status change, if the recovery flag of the related minor resources of the application allows automation.
- If this command is called on a task other than the AOFWRKxx auto operator that is responsible for the subsystem, HALTMSG will schedule itself to that AOFWRKxx auto operator. The HALTMSG routine will run asynchronously to the calling procedure. This means that when the calling procedure regains control, the status of the subsystem may not yet have changed.
- Only messages for applications with known address space IDs are processed by HALTMSG.

The address space ID is not checked if HALTMSG is called from an automation procedure (CLIST), or if HALTMSG has been triggered by message BPXF024I.

Usage

Applications can be put into HALTED status when something occurs that leaves them running with reduced function. Use HALTMSG to put an application into HALTED status, and ACTIVMSG (or the SETSTATE command dialog) to change the status.

If HALTMSG is called for a WTOR and it is not replied to, OUTREP is called to process the WTOR.

HALTMSG

| HALTMSG should run on the working operator of the subsystem that issued the
| message. Otherwise, the HALTMSG routine will run asynchronously to the calling
| procedure. This means that when the calling procedure regains control, the status
| of the affected subsystem may not yet have changed.

| All commands and replies that are triggered through HALTMSG have access to the
| SAFE called AOFMSAFE, which stores the message that caused the HALTMSG
| call.

Task Global Variables

EHKVAR0 through EHKVAR9 and EHKVART

When defining the commands in the automation control file to be issued by generic routine HALTMSG, the variables &EHKVAR0 through &EHKVAR9 and &EHKVART can be used to be substituted by the tokens of the parsed message that has driven HALTMSG. &EHKVAR0 will be substituted by the message ID, &EHKVAR1 by the first token of the message text after the message ID, &EHKVAR2 with the second token and so forth. &EHKVART will be substituted by the trailing message text after the 9th token.

Examples

The following example shows how HALTMSG is called from the NetView automation table:

```
* IKT008I TCAS NOT ACCEPTING LOGONS  
IF MSGID = 'IKT008I' & DOMAINID = %AOFDOM% THEN  
EXEC( CMD('HALTMSG')  
ROUTE(ONE %AOFOPGSSOPER%));
```

INGMON

Purpose

INGMON is a generic routine that can be called from the NetView automation table. It is used to tell SA z/OS the status for a monitoring resource and to issue commands in response to a message or an OMEGAMON[®] exception.

Syntax

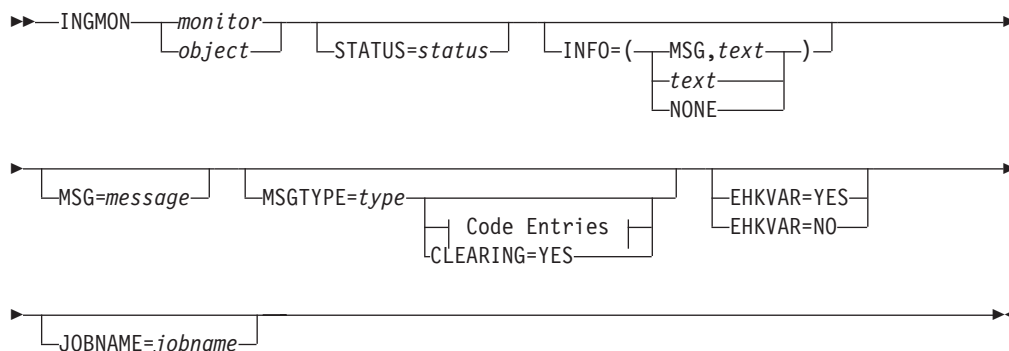

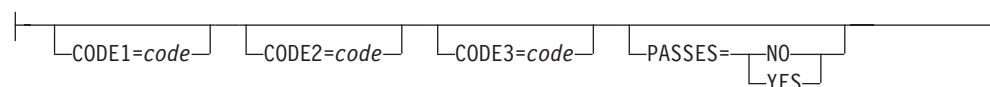
Code Entries:**Parameters***monitor*

This is the name of a monitor resource. It can be specified in automation manager notation (for example, SAPMON/MTR/AOC8) or in agent notation.

object

This is the name of a monitored object as defined in the MTR policy in the customization dialog. INGMON automatically finds the corresponding monitor resources and operates on them.

Note that a monitor resource with that name is searched first. Then, if it is not found, a search for a monitored object is performed.

Note: Be careful not to specify objects that have the same name as an existing monitor resource, otherwise INGMON will only find the entry for the monitor resource and not for the object. For example, if you have a monitor resource, ABC, and you define a second monitor resource, XYZ, with a monitored object called ABC, the call INGMON ABC will always find the monitor resource ABC and never the object ABC that has been defined for XYZ.

STATUS

This is the new state that the monitor has determined. The state represents either the health status of the objects that the monitor is watching, or the state that the monitor is in. The latter can be one of the following:

INACTIVE

The monitor is not running.

FAILED

The monitor has failed. Recovery may be in progress. No acceptable health status was provided.

BROKEN

Both the monitor and recovery failed. This is a permanent condition. The monitor will not be re-invoked.

The health status of the object, or objects, that the monitor is watching are as follows, from the least to the most serious:

UNKNOWN

The health status is not yet available.

NORMAL

The monitor has obtained good results from the object, or objects, that it is watching.

WARNING

The monitor detected a certain degree of degradation in the operation of the monitored object.

MINOR

The same as WARNING, but more severe.

CRITICAL

The same as MINOR, but more severe.

FATAL

The same as CRITICAL, but more severe.

INFO

This defines the message that is associated with the new health status. The parameter value must be enclosed in parentheses, or single or double quotation marks. If not present, the value of the MSG parameter will be used instead. If neither parameter is present, text will be constructed from whatever is in the default safe.

MSG,*text*

The specified text is associated with the new health status.

In SDF, when displaying the new health status via message AOF550I, the text is shortened to "MESSAGE *message_ID* RECEIVED", where *message_ID* is the first token of the given text.

text

The specified text is associated with the new health status.

NONE

No message is associated with the status.

MSG

This defines the text of the message that commands or replies are defined for in the MESSAGES/USER DATA policy item of the policy database.

message

The message must be enclosed in parentheses, or single or double quotation marks. If not present, the content of the default safe will be taken instead.

MSGTYPE

This is the value entered in the **Message ID** field in the customization dialog for the MESSAGES/USER DATA policy item (the entry type field in the automation control file entry for the command). MSGTYPE is typically coded with the message ID or the OMEGAMON exception identifier, such as XCHN or SWPC.

If not present, the first token of the value of MSG parameter will be used instead. If neither parameter is present, the message ID will be extracted from the message in the default safe.

The task global variables EHKVAR n contain the parsed message from either the MSG parameter or, if not present, the message in the default safe.

CODE n

When specified, the passed codes are used to search the code entries for a particular Message ID or exception that is specified in the policy item MESSAGES/USER DATA. The first token of the value returned is used as an option to select the commands to be issued from the automation control file (the value gives a set of commands). If no match occurs for the specified codes, or if no codes are specified, the value ALWAYS is used to select the commands to be issued.

As a selection you must specify one of the following:

- # Perform pass processing and execute all commands with a selection matching the current pass or blank.

Note that this overrides the PASSES keyword with YES.

#type Interpret type as a message type. Do pass processing for this message and execute all commands with a selection matching the current pass or blank.

Note that this overrides the PASSES keyword with YES.

This is like calling INGMON with MSGTYPE=*id*.

Others

Execute all commands with the given selection, or blank.

The second token of the value returned is used to determine the health status to be set. If specified it must denote one of the values listed under the STATUS keyword. If no match occurs, or the second token is omitted, the value given on the STATUS keyword is used.

The CODE parameters are mutually exclusive to the PASSES=YES parameter.

PASSES

Specifies whether passes are used to issue the commands. The INGMON routine interrogates the automation control file to see if passes are specified in the command entries. If so, PASSES=YES is defaulted unless PASSES=NO was specified when calling INGMON.

NO

Passes are not used to issue the commands.

YES

Passes are used to issue the commands. The pass count is incremented every time INGMON is called. The pass count is keyed by monitor name and by message type or exception (that is, the OM exception). The count is automatically reset when the monitor resource is deactivated, or when INGMON is invoked with the CLEARING option.

CLEARING

Indicates that this is a clearing event. The situation that caused the message or exception is no longer present. It resets the pass count and removes the mask (DISABLETIME) for this message or exception.

EHKVAR

This parameter determines whether the tokens of the parsed message text are to be stored in task global variables EHKVAR0 through EHKVAR9 and EHKVART.

YES

The tokens of the triggering message are to be assigned to the task global variables EHKVAR*n*.

NO

No values are to be assigned to the task global variables EHKVAR*n*.

JOBNAME

Indicates that the job name that is given is to be used rather than the one obtained by the jobname() function to match a monitored object to the corresponding monitor resources.

If the monitor resource contains a value in the monitored job name field it is only considered a match when both the monitored object and the given job name match.

INGMON

If JOBNAME is omitted the jobname() function is used to determine the name of the job that issued the triggering message. If a job name cannot be determined the value N/A is used.

JOBNAME is required when INGMON is not message driven.

Return Codes

- 0 Okay.
- 1 An error occurred.
- 2 A monitor resource or monitored object with the specified name does not exist.

Restrictions and Limitations

Only the following STATUS changes are possible:

- From BROKEN to INACTIVE (via line command a in DISPMTR, for example)
- From any active status (FAILED, UNKNOWN, NORMAL, WARNING, MINOR, CRITICAL, or FATAL) to any other status

Usage

The message that caused the INGMON call is stored in the SAFE named AOFMSAFE. All commands and replies that are triggered through INGMON have access to this SAFE.

Task Global Variables

EHKVAR0 through EHKVAR9 and EHKVART

When defining the commands in the automation control file to be issued by the INGMON routine, the variables &EHKVAR0 through &EHKVAR9 and &EHKVART can be used to be substituted by the tokens of the parsed message that has driven INGMON. &EHKVAR0 will be substituted by the message ID, &EHKVAR1 by the first token of the message text after the message ID, &EHKVAR2 with the second token, and so forth. &EHKVART will be substituted by the trailing message text after the 9th token.

When INGMON is driven by an ING080I message (generated by SA z/OS), for an OMEGAMON exception, &EHKVAR0 contains the exception identifier, &EHKVAR1 contains the first token of the text following the exception identifier, and so on, and &EHKVART contains the message or exception text.

Additionally, the following task global variables are set:

SUBSAPPL

The monitor name.

SUBDESC

The monitor resource description from the automation control file.

SUBSTYPE

The resource type. Contains MONITOR.

Note: If there is no triggering message (for example, when INGMON is called from the ACF within INGMON processing) EHKVAR0 through EHKVAR9 and EHKVART are not available.

Examples

Example 1

Call pager routine when channel path 26 is not operational. The MESSAGE/USER DATA policy definition contains an entry for "+ XCHN" as follows:

CMD entry

```
PAGER &SUBSAPPL,&EHKVAR0,&EHKVAR4
```

where:

- PAGER is the name of the clist that handles the paging
- &SUBSAPPL contains the monitor name
- &EHKVAR0 contains the exception ID
- &EHKVAR4 contains the CHPID

Note that the "+ " prefix, written as a '+' followed by a blank in front of the exception identifier, is used to distinguish a normal message from an OMEGAMON exception.

CODE entry

CODE1	CODE2	CODE3	Value Returned
26	*	*	ALWAYS
*	*	*	IGNORE

OVR entry

The standard AT entry pattern is generated by SA z/OS. You can change the condition statement to assign TOKEN(10), which contains the missing channel number to a variable, for example, MISSCHAN.

The pattern of the action statement would be changed to pass that variable to INGMON, that is:

```
EXEC (CMD('INGMON monitor CODE1='MISSCHAN))
```

It is assumed that token 10 in message ING080I contains the channel path. The command fragment up to the monitor name is automatically generated by the customization dialog. The message type (that is, exception ID) is available to INGMON indirectly through the default SAFE.

You can append additional parameters through such an OVR entry.

Example 2

The installation fixed the problem with the missing channel path as shown in the previous example. To indicate that the situation that caused the exception no longer exists and that the recovery action has been successfully processed, use:

```
INGMON monitor MSGTYPE=XCHN CLEARING=YES
```

Example 3

Send Alert when CICS Link LNKA2B is not operational. The MONITOR INFO policy definition contains the following:

```

Monitored Object . . . . . CICSPLX1.LINK.LNKA2B _____
Monitored Jobname. . . . . _____
Activate command . . . . . _____
_____
_____

Deactivate command . . . . . _____
_____
_____

Monitor command. . . . . _____
_____
_____

Monitoring Interval. . . . . _____ (hh:mm or blank)
Captured Messages Limit. . . . . _____ (0 to 999, or blank)
Desired Available. . . . . _____ (ALWAYS ONDEMAND or blank)
Inform List. . . . . IOM _____ (SDF NMC IOM SMF NONE)
Owner. . . . . _____
Info Link. . . . . _____
    
```

The MESSAGE/USER DATA policy definition contains an entry for ING150I as follows:

CODE entry

CODE1	CODE2	CODE3	Value Returned
L*	*	*	NOP WARNING
HW	*	*	NOP MINOR
*HS	*	*	#MSGCRIT CRITICAL
*	*	*	NOP NORMAL

Because we want no command to be issued for health status WARNING, MINOR and NORMAL we use an arbitrary selection (NOP). A selection is required, because the health status must be the second token.

For the CRITICAL case we have INGMON jump to message type MSGCRIT and execute the commands listed there. In our example this would probably be an INGALERT command.

We want the pass counts to be reset as soon as the health status returns to NORMAL, so we specify in the HEALTHSTATE policy definition:

```
INGMON monitor MSGTYPE=MSGCRIT CLEARING=YES
```

ISSUEACT (ISSUECMD, ISSUEREP)

Purpose

ISSUEACT, ISSUECMD and ISSUEREP are defined as synonyms for the same generic routine, which can be used to trigger your own commands, replies, or both, from messages that are defined in the automation policy item MESSAGES/USER DATA under consideration of the automation flags.

If the generic routine is called as ISSUECMD, only commands are issued, whereas if it is called as ISSUEREP, only replies are issued. When called as ISSUEACT, the generic routine issues commands and replies according to the given selection criteria that are passed as parameters.

In addition, this generic routine includes special message processing for some critical DB2 messages and for JES2 message \$HASP099. For further details see the sections "Critical Event Monitoring" and "JES2 Shutdown Processing" in *IBM Tivoli System Automation for z/OS Customizing and Programming*.

Syntax

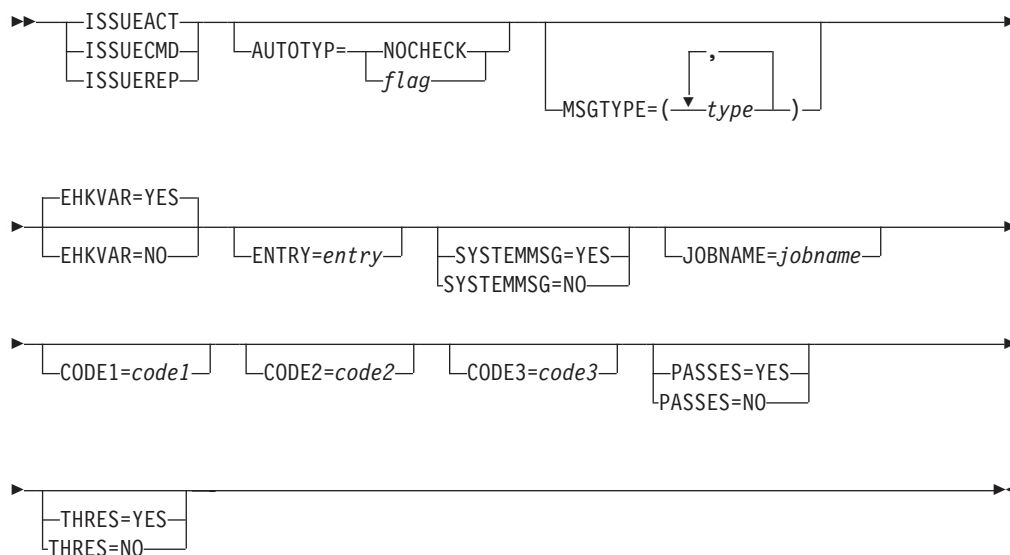

Parameters

AUTOTYP

The automation flag that is to be checked. If the flag is turned off no commands or replies are issued.

NOCHECK

If NOCHECK is specified, the RECOVERY flag is checked, but the commands or replies (or both) are issued regardless of its setting.

flag

flag must be one of the following:

- AUTOMATION
- INITSTART
- RECOVERY
- RESTART
- START
- TERMINATE

If SYSTEMMSG=YES is specified, NOCHECK, AUTOMATION and RECOVERY are the only valid values.

If no AUTOTYP value is coded and SYSTEMMSG=YES, AUTOTYP defaults to RECOVERY.

If no AUTOTYP value is coded and SYSTEMMSG=NO, the default value is determined according to the following steps:

1. If startup of the application is in progress, AUTOTYP=START

ISSUEACT

2. If shutdown of the application is in progress, AUTOTYP=TERMINATE
3. If neither a startup nor a shutdown is in progress, a value for AUTOTYP is taken that corresponds to the actual status of the application:

AUTOTYP	Actual Status
START	ACTIVE, ENDING, EXTSTART, RESTART, RUNNING, STARTED, STARTED2
TERMINATE	ABENDING, AUTOTERM, BREAKING, HALFDOWN, STOPPING, STUCK, ZOMBIE
RECOVERY	AUTODOWN, BROKEN, CTLDOWN, DOWN, ENDED, FALLBACK, HALTED, INACTIVE, MOVED, STOPPED, UP

4. If no actual status information is available, RECOVERY is taken as the default value for AUTOTYP

MSGTYPE

This value is a list of the message IDs in the MESSAGES/USER DATA policy item where the commands or replies (or both) to be issued are defined. It defaults to the ID of the message that initiated ISSUEACT, ISSUECMD or ISSUEREP, if the generic routine is called from the NetView automation table. If the generic routine is not driven by a message, you must supply this parameter.

The embedding brackets are not needed if only one message ID is specified.

EHKVAR

This parameter determines whether the tokens of the parsed message text are to be stored in task global variables EHKVAR0 through EHKVAR9 and EHKVART.

YES

The tokens of the triggering message are to be assigned to the task global variables EHKVAR n .

NO

No values are to be assigned to the task global variables EHKVAR n .

ENTRY

This value is the entry name of the definition in the automation policy where the commands or replies (or both) to be issued are defined.

- If ISSUEACT, ISSUECMD or ISSUEREP is called from the NetView automation table, *entry* defaults to:
 - The application name, as determined from the job name, for application messages
 - The system type (MVSESA) for system messages
- Otherwise you must supply this parameter.

JOBNAME

This parameter is used to pass the job name when ISSUEACT, ISSUECMD or ISSUEREP is not called from the NetView automation table.

REPLYID

This parameter is used to pass the reply ID when the generic routine has to reply to a WTOR, but has not been called from the NetView automation table.

Note: This parameter is not valid if the generic routine is called as ISSUECMD.

SYSTEMMSG

Indicates whether the message is a system message or an application message.

YES

The message was issued by a system rather than an application. SYSTEMMSG defaults to YES if no job name can be obtained from the message details, and neither the JOBNAME nor the ENTRY parameter is specified. Furthermore it defaults to YES, if the job name that is obtained is not defined to SA z/OS and if, in addition, no ENTRY parameter is specified or its value is the system type (MVSESA).

NO

The message was issued by an application that must be defined to SA z/OS.

CODE1=code1 CODE2=code2 CODE3=code3

When specified, the codes that are passed are used to search for code entries for a particular message ID that is specified in the automation policy MESSAGES/USER DATA.

If the generic routine is called as ISSUEACT or ISSUEREP, and if there are no command or reply entries besides the code definition to the given message ID, the response to the matching entry is used as the reply to a WTOR.

Otherwise the response to the matching entry is used as the option to select the commands or replies (or both) to be issued from the automation control file. If no code match occurs for the specified codes, the value ALWAYS is used to select the commands or replies (or both) to be issued.

The CODE-parameters are mutually exclusive to the PASSES=YES parameter.

MSG

This parameter is used to pass an alternate message text when ISSUEREP or ISSUEACT is triggered by a WTOR. The value of this parameter is used as the message text instead of the message text of the triggering message to be forwarded to SDF and NMC.

This parameter is rejected if the generic routine is called as ISSUECMD.

PASSES

Specifies whether passes are used to issue the commands or replies.

YES

Passes are used to issue the commands or replies. The pass count is incremented only if the automation flag is turned on. The pass count is keyed by message ID, and for normal messages the count is reset when the application is shut down. For system messages, the pass count is reset when NetView is recycled.

This value is mutually exclusive to the CODE parameters.

NO

Passes are not used to issue the commands or replies.

If PASSES is not coded, it defaults to YES if the AUTOTYP parameter has a value other than START or TERMINATE, and the command or reply entries of the specified ENTRY and MSGTYPE in the automation control file use pass selection options. When START or TERMINATE is the value for the AUTOTYP parameter, YES is only assumed as the default value for the PASSES parameter if there are no command or reply entries defined with a selection name other than PASS nm . In all other cases, the default value to PASSES is set to NO.

ISSUEACT

THRES

Specifies whether defined thresholds for the minor resource *entry.type* are checked before issuing commands or replies.

YES Thresholds are checked before issuing commands or replies.

An error record for minor resource *entry.type* is written to the automation status file and the frequency of the written error records is compared with the defined threshold levels for this resource.

As long as no option has been derived from other criteria (such as the start or stop type, the PASSES parameter or CODE parameters), the name of the exceeded threshold level (ALWAYS, INFR, FREQ, or CRIT) is used to select defined commands or replies with these selection options. If no commands or replies with these selection options are defined, all commands or replies defined for the given entry and type are issued if the critical threshold has not been exceeded.

If a selection option has already been provided by other criteria to select commands and replies, these commands or replies are only issued if the critical threshold has not been exceeded.

NO Thresholds are not checked before issuing commands or replies.

If THRES is not coded, its value defaults to YES if there are thresholds defined for the minor resource *entry.type*. Otherwise the value of THRES is assumed to be NO.

Restrictions and Limitations

- ISSUEACT, ISSUECMD and ISSUEREP will only work when SA z/OS is fully initialized.
- SYSTEMMSG=YES is only accepted if no job name is provided by the JOBNAME parameter and no ENTRY parameter is specified or the value of the common global variable AOFSYSTEM is passed as the value for it.
- SYSTEMMSG=YES is only valid in combination with the AUTOTYP values NOCHECK, RECOVERY, or AUTOMATION.
- If ISSUEACT, ISSUECMD or ISSUEREP is driven by a delete operator message, no commands or replies are issued that are driven by such a message.
- The generic routine has to run on the working operator task of the application.

Usage

The triggering message of this routine is stored in the named SAFE AOFMSAFE. All commands that are triggered through this routine and that are executed on the task that is currently executing this routine have access to this SAFE.

Do not call OUTREP in addition to this generic routine for a triggering WTOR. If the triggering WTOR is not replied to in ISSUEACT, ISSUECMD or ISSUEREP, OUTREP is automatically called to record the WTOR.

If AUTOTYP=START is flagged and PASSES=NO and no CODE parameters are specified, the current start type will be taken as the selection for the commands or replies to be issued. If no start type is provided, NORM is assumed as the default start type.

If AUTOTYP=TERMINATE is flagged and PASSES=NO, and no CODE parameters are specified, the current stop type will be taken as the selection for the commands or replies to be issued. If no stop type is provided, NORM is assumed as the default stop type.

If no selection option has been derived from criteria such as start or stop type, PASSES parameter, CODE parameters or the result of threshold checking, ALWAYS is assumed as the default option for selecting defined commands or replies to be issued.

If the value of the advanced automation option AOFSTATUSCMDSEL is set to zero, all defined commands or replies for a specified status as message ID are issued, regardless of any defined selection option. This means that no option from criteria such as start or stop type, PASSES parameter, CODE parameters or the results of threshold checking is used to select defined commands or replies. No minor resource threshold checking is done in this case.

Task Global Variables

EHKVAR0 through EHKVAR9 and EHKVART

When defining the commands or replies in the automation policy that are to be issued by this generic routine, the variables &EHKVAR0 through &EHKVAR9 and &EHKVART can be used to be substituted by the tokens of the parsed message that has driven this routine. &EHKVAR0 will be substituted by the message ID, &EHKVAR1 by the first token of the message text after the message ID, &EHKVAR2 with the second token and so forth. &EHKVART will be substituted by the trailing message text after the 9th token.

Examples

Example 1

This example shows an automation procedure that calls the generic routine ISSUEACT to handle the HSM subsystem message, ARC0027I.

The automation policy is as follows:

```

AOFK3D0X          SA z/OS - Command Response          Line 1   of 4
Domain ID   = IPSNO   ----- DISPACF -----         Date = 07/19/00
Operator ID = SAUSER                                     Time = 18:20:45

Command = ACF ENTRY=HSM,TYPE=ARC0027I,REQ=DISP
SYSTEM = KEY3      AUTOMATION CONFIGURATION DISPLAY - ENTRY= HSM
-----
AUTOMATION CONFIGURATION DISPLAY - ENTRY= HSM
TYPE IS ARC0027I
CMD          = (,,'MVS S HSMPL0GB')
END OF MULTI-LINE MESSAGE GROUP

```

Figure 5. DISPACF Sample Panel

The NetView automation table entry to call ISSUEACT is:

```

IF MSGID = 'ARC0027I' THEN
EXEC(CMD('ISSUEACT') ROUTE(ONE %AOFOPGSSOPER%));

```

The automation flag to check depends on the phase in the life cycle of the HSM subsystem. If no start up or shutdown is in progress for the application, ISSUEACT checks the recovery flag to validate that automation is allowed before issuing the

ISSUEACT

command. If automation is allowed and message ARC0027I is received for job DFHSM, relating to the HSM subsystem, a command is issued that saves the HSM data set. If message ARC0027I is received for any job other than DFHSM, the message is not automated.

If you specify a clist named MYCLIST instead of an MVS command for the message ARC0027I in the message policy of the customization dialog, this clist can access the original message that triggered ISSUEACT via the named safe AOFMSAFE. Thus you are able to access the message attributes and all lines of a multiline message. The code to access this safe should look similar to the following:

```
/* MYCLIST */  
  
...  
  
/* Get the message from the SAFE called AOFMSAFE */  
"PIPE (STAGESEP | NAME GETMSG)" ,  
  "SAFE AOFMSAFE" ,  
  "| STEM orig_msg."  
  
...  
  
Exit
```

Example 2

This example shows how ISSUEACT can be used to automatically respond to WTOR AHL125A, which is issued by GTF during initialization and which allows SA z/OS to accept or reject the trace options that GTF will use.

To enable SA z/OS to automatically accept the trace options, define value U as the reply to message AHL125A. To do this, select the MESSAGES/USER DATA policy item from the Policy Selection panel for the GTF subsystem in the customization dialog. In the Message Processing panel, specify AHL125A as the message ID and call action REP to get the related Reply Processing panel. Specify U in the **Reply Text** field.

Return to the Message Processing panel.

When you call action OVR, you can see that the automation table entry that will be created during the build process for the automation policy:

```
IF MSGID = 'AHL125A' THEN  
EXEC(CMD('ISSUEACT') ROUTE(ONE %AOFOPGSSOPER%));
```

ISSUEACT is called without parameters. Therefore the automation flag to be checked depends on the phase in the lifecycle of the GTF subsystem. Because message AHL125A is issued during the initialization of GTF, ISSUEACT checks the start flag to validate that automation is allowed before issuing the reply.

If automation is allowed and message AHL125A is received for job GTFPROD that is related to the GTF subsystem, ISSUEACT replies with value U to accept the trace options and to continue its initialization. If message AHL125A is received for any job other than GTFPROD, the message is not automated.

OUTREP

Purpose

The OUTREP routine captures and saves MVS reply identifiers for applications that issue outstanding replies. Some applications issue an outstanding reply when they start, and that reply is used for critical operator communication or shutdown commands. This routine captures these reply IDs and their message text and saves them in case the automation code needs them for recovery or shutdown.

Typically, OUTREP is called from the NetView automation table.

Syntax

```

▶▶—OUTREP—┐
               └──message──┘
  
```

Parameters

message

The message text for the outstanding reply. If not specified it will be picked up from the default safe.

Restrictions and Limitations

If another generic routine such as ISSUEACT/ISSUEREP/ISSUECMD, ACTIVMSG, HALTMSG, TERMMSG or INGMON is called for the WTOR, you should not code an additional call to OUTREP for the same WTOR. If the generic routine cannot find a value to reply to the WTOR with, it automatically calls OUTREP to record the WTOR. This also happens if the generic routine is called and finds that the automation for the message is turned off.

Usage

This routine attempts to determine the application name from the job name that is associated with the message. It then calls CDEMATCH with:

```

CODE1=msgid
CODE2=jobname
  
```

to determine what is to be done with the outstanding WTOR.

If an application is found, CDEMATCH searches the Automation Control File for CODE entries that are associated with ENTRY-TYPE pairs of *application*-WTORS where *application* is the application name as determined from the job name.

If an application cannot be found, or there is no match from the first search, CDEMATCH searches CODE entries that are associated with ENTRY-TYPE keys of MVSESA-WTORS.

If a successful match occurs, CDEMATCH returns a value consisting of two words that instruct OUTREP what to do with the WTOR:

- **First word:** Assigns the severity that determines the color of the WTOR in SDF and NMC.

- **Second word:** Assigns the priority. WTORS with a priority of PRIMARY are used by SA z/OS as outstanding WTORS but those with a priority of SECONDARY are not.

The following table shows the valid values for the severity with the resulting status in SDF and the colors of the WTORS in SDF and NMC.

Severity	Status in SDF	Default Color in SDF	Color in NMC
NORMAL	NWTOR	Green	Green
UNUSUAL	UWTOR	Yellow	White
IMPORTANT	IWTOR	Red	Red
IGNORE	-	-	-

Any definite abbreviation can be used to specify the severity.

By default an incoming WTOR is considered to be of priority PRIMARY with a severity of UNUSUAL. This also means that any code definitions where you have entered incorrect data in the **Value Returned** field default to UNUSUAL PRI.

The codes that CDEMATCH is to search on are entered against a message ID of WTORS in the Code Processing panels of the customization dialogs. Figure 6 shows an example of code definitions to the message ID WTORS that are specified at the entry of the NetView application with job name NETVAPPL.

Figure 7 shows an example of code entries for the MVSESA resource.

Code 1	Code 2	Code 3	Value Returned
DSI802A	*		NORMAL PRI
DSI803A	*		NORMAL PRI
TEST001	*		NORMAL SEC

Figure 6. Code Processing Panel for an Application Resource

Code 1	Code 2	Code 3	Value Returned
IEA793A	*		IMPORTANT SEC
IEC507D	*		NORMAL SEC
IEF235D	*		NORMAL SEC
IEF238D	*		IMPORTANT SEC
IEF455D	*		NORMAL SEC
IEF458D	*		NORMAL SEC

Figure 7. Code Processing Panel for the MVSESA Resource

These code entries result in the following behavior:

- If the job NETVAPPL issues one of the messages DSI802A or DSI803A, it is assigned a severity of NORMAL and is displayed in the related color in SDF and NMC. SA z/OS can use this outstanding reply, for example, to shut down job NETVAPPL.
- If any Clist running in NetView with job name NETVAPPL issues a WTOR with message ID TEST001, it is also assigned a severity of NORMAL and is displayed in the relating color in SDF and NMC, but it cannot be used to shut down this NetView.
- If one of the messages defined in the code entries to the MVSESA resource in Figure 7 is issued by any application or MVS component, and no replies are

defined in SA z/OS to be issued in response to them, these messages are stored as secondary WTORS and are displayed in SDF and NMC with the specified severity.

Task Global Variables

None.

Examples

The following is an example of calling the OUTREP routine directly from the NetView automation table:

```
IF MSGID='DSI802A' & DOMAINID = %AOFDOM%
THEN
EXEC(CMD('OUTREP') ROUTE(ONE %AOFOPSYSOPER%));
```

In this example, OUTREP is called for the NetView outstanding reply message, DSI802A. %AOFDOM% is a synonym defined to be the current domain. %AOFOPSYSOPER% is a cascade for processing WTORS. Both are defined in AOFMSGSY.

TERMMMSG

Purpose

You can use the TERMMMSG generic routine to respond to the termination message of an application by changing the SA z/OS status of the application. TERMMMSG calls the ISSUEACT generic routine to also issue commands and replies that are defined in the automation policy for the ID of the termination message and for the new status. Typically, TERMMMSG is called from the NetView automation table.

The status that the application is placed in by TERMMMSG depends on a number of conditions, including the values of the FINAL, ABEND, and BREAK parameters. The values of the FINAL, ABEND and BREAK parameters may in turn depend on the values of the CODE parameters. The following table shows the statuses that TERMMMSG may place an application in.

Table 7. TERMMMSG Status Transitions

Status	Description	Final	Abend	Break
STOPPING	Application terminated externally	N	N	N
ENDING	For transient applications	N	N	N
ABENDING	Application abend	N	Y	N
BREAKING	Non-recoverable abend	N	N	Y
STOPPED	Application shutdown externally	Y	N	N
ENDED	Transient application shutdown	Y	N	N
BROKEN	Non-recoverable abend	Y	N	Y
RESTART	Restart after abend	Y	Y	N
AUTOTERM	No change during shutdown	N	N	N
AUTODOWN or RESTART	System is being shut down. The status will depend on the shutdown parameters.	Y	?	?
ZOMBIE	Occurs if there are problems with the address space cleanup.	Y	?	?

TERMMSG

For information about how the CODE parameters can affect the values of FINAL, ABEND, and BREAK see the description of "The CODE Parameter" on page 129.

Syntax

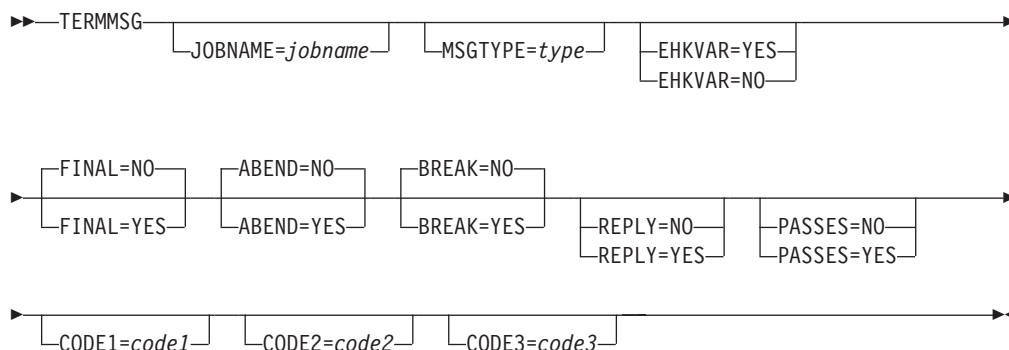

Parameters

JOBNAME

The name of the job that the message is for. If not specified, the job name is taken from the message's job name field. You must supply a value for the job name if you are calling TERMMSG from a CLIST.

MSGTYPE

This parameter is used to search for command and reply entries to *subsystem/msgtype*-pairs in the automation control file, where *subsystem* is the subsystem name derived from the job name.

When a match occurs, the commands associated with the entries are issued.

If the MSGTYPE parameter is not specified, the message identifier of the message that TERMMSG is called for is taken as the default.

EHKVAR

This parameter determines whether the tokens of the parsed message text are to be stored in task global variables EHKVAR0 through EHKVAR9 and EHKVART.

YES

The tokens of the triggering message are to be assigned to the task global variables EHKVAR n .

NO

No values are to be assigned to the task global variables EHKVAR n .

FINAL

Indicates whether this is the final termination message. If no FINAL value is coded, TERMMSG defaults to FINAL=NO.

YES

The message is the final termination message for the application. The application will be placed into the appropriate status, depending on the values of the ABEND and BREAK parameters. See Table 7 on page 127 for details. If it is monitorable, the application is not placed into a down status until an application monitor check confirms that it has left the machine. If it is not monitorable, the application is placed into a down status after its termination delay time.

NO

This is not the final termination message.

ABEND

Indicates whether the application is suffering a recoverable abend. If no ABEND value is coded, TERMMMSG defaults to ABEND=NO.

YES

The application is suffering a recoverable abend. The application will be placed into the appropriate status, depending on the value of the FINAL parameter. See Table 7 on page 127 for details.

When the final termination message for an abending application (FINAL=YES) is received, the error threshold is checked and the application is restarted if it has not exceeded its critical error threshold.

NO

The application is not suffering a recoverable abend.

BREAK

Indicates whether the application is suffering a non-recoverable abend. The application will be placed into the appropriate status, depending on the value of the FINAL parameter. If no BREAK value is coded, TERMMMSG defaults to BREAK=NO.

YES

The application is suffering a non-recoverable abend and should be placed into BREAKING status. When its final termination message is received (FINAL=YES) it is placed into BROKEN status. SA z/OS will not restart it from this status without human intervention through the SETSTATE command dialog.

NO

The application is not suffering a non-recoverable abend.

REPLY

This parameter determines whether a defined reply is issued for a message that TERMMMSG has been called for.

YES

A defined reply in the automation policy for the message that is being handled by TERMMMSG is issued. REPLY=YES is assumed as the default if the message is a WTOR, otherwise the default is REPLY=NO.

NO

A defined reply for a WTOR that is being handled by TERMMMSG is not issued.

PASSES

Specifies whether passes are used to issue commands or replies (or both) that have been defined in the automation policy.

YES

PASSES=YES is passed to the ISSUEACT generic routine.

NO

PASSES=NO is passed to the ISSUEACT generic routine.

CODE1=code1 CODE2=code2 CODE3=code3

When specified, the codes that are passed are used to search for code definitions for the termination message in the automation policy MESSAGES/USER DATA. First the automation policy is searched for code definitions against the message ID of the subsystem that issued the termination

TERMMSG

message. If these cannot be found, the automation policy is searched for code definitions against the message ID MVSESA.

The meaning of the codes depends on the NetView automation table entry that invoked TERMMSG.

The value returned for the matching code definition can consist of two tokens. The first token is used as the action to modify the FINAL, ABEND and BREAK parameters of TERMMSG in the following way:

Action	Final	Abend	Break
STOPPING	-	-	-
STOPPED	Yes	-	-
ABENDING	-	Yes	-
ABENDED	Yes	Yes	-
BREAKING	-	-	Yes
BROKEN	Yes	-	Yes

If specified, the second token of the returned value is used as the start type for the subsystem's next startup. The next start type is set with the INGSET command.

TERMMSG does not apply the code values for selecting defined commands or replies to be issued.

Restrictions and Limitations

- If TERMMSG is driven by a delete operator message, no action is taken in response to this message.
- If a normal termination message (ABEND=NO,BREAK=NO) is received for an application that is not being shut down by SA z/OS (and is already in the AUTOTERM status), it is placed into STOPPING status. When its final termination message has been processed, its Restart option is checked. If this is ALWAYS it is placed into RESTART status, if not it will be placed into STOPPED status.

This behavior can be changed using the AOFRESTARTALWAYS advanced automation option.

- Once an application has entered a serious error condition (a status of AUTOTERM, STOPPING, ABENDING, or BREAKING), termination messages indicating less important error conditions are ignored.
- Commands for a status are only issued the first time the status is entered.
- If this command is called on a task other than the AOFWRKxx auto operator that is responsible for the subsystem, TERMMSG will schedule itself to that AOFWRKxx auto operator. This means that when the calling procedure regains control, the status of the subsystem may not yet have changed.
- Only termination messages for applications with known address space IDs are processed by TERMMSG.

The address space ID is not checked if TERMMSG is called from an automation procedure (CLIST), or if TERMMSG has been triggered by message BPXF024I.

The address space ID is also ignored if the job name parameter that was specified differs from the job name associated with the triggering message.

Usage

The definition of termination messages ensures early detection of any problems with subsystems. A number of termination messages is already known to SA z/OS. To define an additional termination message, specify it in the MESSAGES/USER DATA automation policy item of the application concerned and mark it as a terminating or terminated status message with action AUTO. During the automation policy build an appropriate NetView automation table statement is created that calls TERMMMSG. See the section about the MESSAGES/USER DATA policy item in *IBM Tivoli System Automation for z/OS Defining Automation Policy* for more details about defining termination messages.

Message IEF404I is used by SA z/OS as the final termination message for all applications. The following example shows how TERMMMSG is called by IEF404I in the automation table:

```
IF MSGID='IEF404I' & TOKEN(2) = SVJOB & DOMAINID=%AOFDOM%
  & ATF('ING$QRY APPL,,JOB='VALUE(SVJOB)) ^= ''
THEN
EXEC(CMD('TERMMMSG FINAL=YES,JOBNAME=' SVJOB) ROUTE(ONE %AOFOPGSSOPER%));
```

The ING\$QRY NetView automation table function is used to screen the message before invoking TERMMMSG. See Chapter 6, “ING\$QRY NetView Automation Table Function,” on page 167 for more information.

Using code definitions to a message obviates the need to code multiple automation table statements or to issue multiple commands to call TERMMMSG.

The following example shows how TERMMMSG is called by generic message IEF450I:

```
IF MSGID='IEF450I' & TOKEN(2) = SVJOB & DOMAINID=%AOFDOM%
  & ATF('ING$QRY APPL,,JOB='VALUE(SVJOB)) ^= ''
  & TEXT = . 'ABEND=' SCODE UCODE .
THEN
EXEC(CMD('TERMMMSG JOBNAME='SVJOB ',CODE1=' SVJOB ',CODE2='
        SCODE ',CODE3=' UCODE) ROUTE(ONE %AOFOPGSSOPER%));
```

Use the command DISPACF MVSESA IEF450I to display the related code definitions for the automation policy, as shown in Figure 8.

```
AOFK3D0X          SA z/OS - Command Response      Line 1   of 11
Domain ID   = IPZFM   ----- DISPACF -----      Date = 07/12/05
Operator ID = SAUSER                                     Time = 15:53:55

Command = ACF ENTRY=MVSESA,TYPE=IEF450I,REQ=DISP
SYSTEM = TSA2          AUTOMATION CONFIGURATION DISPLAY - ENTRY= MVSESA
-----
AUTOMATION CONFIGURATION DISPLAY - ENTRY= MVSESA
TYPE IS IEF450I
CODE          = (*,$913,*, "BROKEN")
CODE          = (*,$306,*, "BROKEN")
CODE          = (*,$122,*, "STOPPED")
CODE          = (*,$222,*, "STOPPED")
CODE          = (*,$422,*, "STOPPED")
CODE          = (*,$522,*, "STOPPED")
CODE          = (*,$047,*, "BROKEN")
CODE          = (*,*,*, "ABENDED")
END OF MULTI-LINE MESSAGE GROUP
```

Figure 8. DISPACF Command Dialog Panel

If you are calling TERMMMSG from an automation procedure, and this calling procedure is not running on the AOFWRKxx automation operator that is

TERMMSG

responsible for the affected subsystem, the TERMMSG routine will be routed to that operator. The TERMMSG routine will run asynchronously to the calling procedure. This means that when the calling procedure regains control, the status of the affected subsystem may not yet have changed.

| All commands and replies that are triggered through TERMMSG have access to the
| SAFE, called AOFMSAFE, that stores the message that caused the TERMMSG call.

Task Global Variables

EHKVAR0 through EHKVAR9 and EHKVART

When defining the commands in the automation control file to be issued by generic routine TERMMSG, the variables &EHKVAR0 through &EHKVAR9 and &EHKVART can be used to be substituted by the tokens of the parsed message that has driven TERMMSG. &EHKVAR0 will be substituted by the message ID, &EHKVAR1 will be substituted by the first token of the message text after the message ID, &EHKVAR2 with the second token and so on. &EHKVART will be substituted by the trailing message text after the 9th token.

Chapter 5. Utilities

SA z/OS provides commands that you can use as system utilities. These commands are:

- "AOFRACON"
- "INGALERT" on page 134
- "INGCPSM" on page 136
- "INGDATA" on page 137
- "INGLINK" on page 139
- "INGMTRAP" on page 142
- "INGOMX" on page 143
- "INGSIT" on page 150
- "INGSTOBS" on page 153
- "INGSTX" on page 155
- "INGTIMER" on page 159
- "INGVARS" on page 162
- "INGVTAM" on page 164

AOFRACON

Purpose

Use the AOFRACON utility to assign an autotask to each MCS console that is not already served by a NetView operator.

If the console *ANY* is assigned to a NetView operator, AOFRACON does not perform console assignments and terminates with RC=1.

If the console *MASTER* is assigned to a NetView operator, the master console gets an autotask assigned anyway, because a switch of the master console would result in this console not having access to NetView.

Syntax

▶▶—AOFRACON—————▶▶

Parameters

None.

Return Codes

- 0 Processing successful.
- 1 Processing not required (*ANY* assignment).
- 4 Processing failed.

Restrictions and Limitations

SA z/OS must be fully initialized prior to running AOFRACON. A suitable exit to run AOFRACON from would be AOFEXINT.

INGALERT

Purpose

The INGALERT command allows you to send alerts to System Automation for Integrated Operations Management (SA IOM).

Syntax

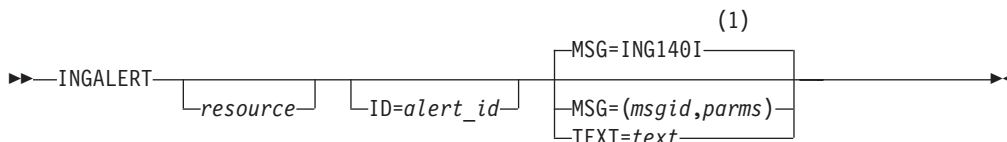

Notes:

- 1 This is the default if INGALERT is not called from the NetView automation table.

Parameters

resource

This can be:

- A fully-qualified resource name, in the form *name/type/sys* (where *type* is APL, APG or MTR)
- The text MVSESA (that is, the content of the AOFSYSTEM variable)
- A job or subsystem name

If INGALERT is called from the AT, *resource* can be omitted, in which case the job name is used. If no job name can be determined, the text MVSESA is used.

ID= This is the alert identifier for the resource. It is user-defined but the following are predefined in SA z/OS:

Alert ID	Description	Resource Type
AS_PROBLEM	Shutdown check for feature failed	APL
CMD_FAILED	Return code checking is on and command ended with RC≠0	APL, MTR
CS_PROBLEM	Compound status PROBLEM has been set	APG
IMPORTANT_WTOR	Important WTOR triggered OUTREP	APL
OS_DEGRADED	The observed status of the resource has become degraded	APL
OS_PROBLEM	The automation status is ZOMBIE, BROKEN or a shutdown outside SA z/OS and restart is not allowed	APL
START_FAILED	Start command failed	APL

Alert ID	Description	Resource Type
START_PENDING	Up message not received within timeout interval	APL
STOP_PENDING	Ran out of stop commands	APL

If INGALERT is called from the AT, *alert_id* can be omitted, in which case the message ID of the triggering message is used.

MSG= This is the ID of a message defined in the NetView message catalog.

Note that if you enter an invalid message ID, the message AOF000I is sent to System Automation for Integrated Operations Management (SA IOM).

The message can have variables &1 through &9 that are filled with parameters that are specified after *msgid*. If a message parameter is omitted the following defaults are used:

- &1** INGALERT
- &2** The date and time stamp when the message was generated
- &3** The alert ID that was specified or the default that was used
- &4** The resource that was specified or the default that was used
- &5** The system that INGALERT was called on

MSG= cannot be used together with TEXT=.

TEXT=*text*

This is a text string that is to be used for the alert.

TEXT= cannot be used together with MSG=.

If neither MSG= nor TEXT = is specified and INGALERT is called from the AT, the text of the triggering message is used. Otherwise MSG=ING140I is used.

Note that the text or message text may be truncated by SA IOM.

Return Codes

- 0** Successful operation.
- 1** Alert is ignored.
- 4** Invalid parameter or parameters.
- 6** Environment check failed.
- 8** Sending of alert failed.

Restrictions and Limitations

SA z/OS must be fully initialized.

The INGALERT command is only available on SA z/OS 3.2 systems within a sysplex. If a resource is specified that is running under an older release an error message is issued.

Usage

Alert transmission can be controlled as follows:

- Alerting can be enabled and disabled systemwide with the INGCNTL command.

INGALERT

- If IOM is specified in the **Inform List** field of the resource's policy, alerting is enabled; otherwise it is disabled.
- Alerting is disabled for a resource if code processing for it is unsuccessful or returns a value of IGNORE.

SA z/OS does not keep track of alerts that have been sent. Once the data has been successfully delivered to SA IOM, responsibility for delivering the alert is passed on to SA IOM. If an alert cannot be sent to SA IOM a message is written to the netlog. No further attempts are made to deliver the alert.

Examples

Example 1:

The following can be used from the NetView automation table to send an alert whenever message ABC123I is issued:

```
IF MSGID='ABC123I'  
THEN  
EXEC(CMD('INGALERT'));
```

This will use alert ID ABC123I and the complete message text of ABC123I as the alert text.

Example 2:

The following can be used from the command line or a CLIST:

```
INGALERT MYGRP/APG/SYS1 ID=MYALERT TEXT=(MYGRP HAS A PROBLEM)
```

This will use alert ID MYALERT and the specified alert text.

INGCPSM

Purpose

The INGCPSM command returns status information for a CICSplex[®] System Manager (CICSplex SM) object. This data is returned in ING150I messages. INGCPSM should be run in a virtual operator station task (VOST).

Syntax

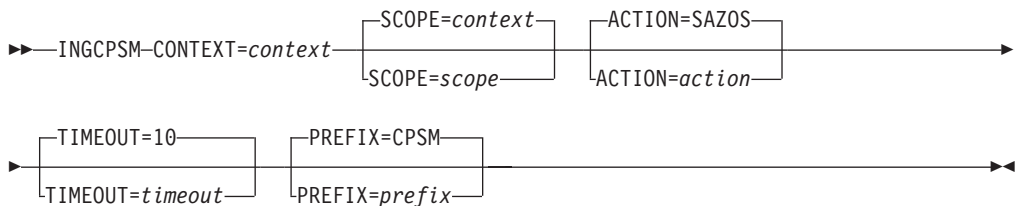

Parameters

CONTEXT

This identifies the context for the command. *context* must be the name of a CICSplex and can be 1–8 characters long. This parameter is required.

Note that a CICSplex SM address space (CMAS) name is not allowed.

SCOPE

This qualifies the CONTEXT option. *scope* can be:

- The 1- to 8-character name of the CICSplex itself
- A CICS system or CICS system group within the CICSplex
- A logical scope, as defined in a CICSplex SM resource description (RESDESC)

If *scope* is not specified the same value that is defined for the context is used.

ACTION

This limits the events that INGCPSM handles to those that are defined with a certain ACTION DEFINITION name.

If *action* is not specified SAZOS is used as the default.

TIMEOUT

This is the number of seconds to wait and collect events before ING150I messages are produced. This is also the interval during which monitor resources that require initial monitoring are determined. The valid range is 1–30 seconds.

If *timeout* is not specified 10 seconds is used as the default.

PREFIX

This is the 1-4 character string that prefixes a monitored CPSM object in the monitor resource. This is used to identify CPSM-related MTRs for initial monitoring.

If *prefix* is not specified CPSM is used as the default.

Return Codes

None.

Restrictions and Limitations

SA z/OS must be fully initialized.

INGCPSM requires CICSplex SM to be installed and ready to use. Appropriate definitions must have been made within CPSM.

Usage

Use INGVSTRT to run INGCPSM in a VOST.

Examples

To start INGCPSM and monitor CICSplex CICPLX1, enter the following as a start command in the VOST management APL:

```
INGVSTRT SYNC,INGCPSM CONTEXT=CICSPLEX1
```

To override the defaults for ACTION and TIMEOUT specify:

```
INGVSTRT SYNC,INGCPSM CONTEXT=CICSPLEX1,ACTION=MYACT,TIMEOUT=30
```

INGDATA

Purpose

The INGDATA command returns detailed information that the automation manager maintains for the specified resources. The data is returned as a multiline message, one line for each resource.

INGDATA

The format is as follows:

Byte	Length	Description
1	11	Name of resource
14	3	Resource type, for example, APG or APL
19	8	Name of system hosting resource
29	11	Observed status
41	12	Desired status
54	10	Automation status
65	4	Automation flag
70	4	Hold flag
75	48	Description
125	10	Start type
137	8	Stop type
147	8	Service period name
157	8	Trigger name
167	12	Compound status
181	10	Startability status
193	8	Resource nature (group type)
203	8	Category
213	10	Subcategory
224	10	Health status

Syntax



Parameters

resource

Specifies the name of the resource (or resources) to be displayed. The format is name/type[</system>]>. It can be a list of names.

The resource names must be separated by a blank. Asterisks (*) can be used as wildcard characters.

WAIT

Specifies the number of seconds to wait before reporting that a timeout occurred if the automation manager does not provide the requested data. The maximum time interval is 999 seconds.

If omitted, the time interval is 30 seconds.

TARGET

For information on the TARGET parameter, refer to *IBM Tivoli System Automation for z/OS Operator's Commands*.

Return Codes

- 0 Okay.
- 1 An error occurred.
- 2 SA z/OS has not fully initialized.

Restrictions and Limitations

SA z/OS must be fully initialized.

Usage

The command is to be used within a NetView PIPE statement.

INGLINK

Purpose

The INGLINK command lets you:

- Activate and deactivate a link between a consumer and a provider application that is defined as a dynamic link in the automation policy
- Query the status of a link between a consumer and a provider application as defined in the automation policy

A *consumer* is an application that has messages defined for it with a prefix of UP_ or DN_ and with a suffix of a valid subsystem name.

A *provider* is an application whose subsystem name is used as the suffix for an UP_ or DN_ message that is defined for any application.

Syntax

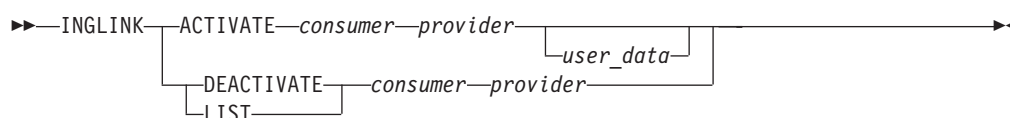

Parameters

A(CTIVATE)

Activates a link between a consumer and a provider application that is defined as a dynamic link in the automation policy. The link state changes to ACTIVE.

This function requires a fully-qualified consumer and provider name, that is, the name cannot contain any wildcards. You do not need to specify the full resource name.

Subsystem or job names are accepted. Subsystem names have preference.

D(EACTIVATE)

Deactivates a link between a consumer and a provider application that is defined as a dynamic link in the automation policy. The link state changes to INACTIVE.

This function requires a fully-qualified consumer name. The provider name can be either fully-qualified (that is, the name cannot contain any wildcards) or an asterisk '*' to refer to all providers.

INGLINK

Subsystem or job names are accepted. Subsystem names have preference.

L(IST)

Displays links between consumer and provider applications and their current state.

This function supports wildcard names for consumers and providers. The consumer and provider names must be subsystem names.

consumer

The subsystem name of an application that uses services provided by another application.

provider

The subsystem name of an application that provides services used by another application.

user_data

User data can be set when you use the ACTIVATE function. The data is stored as additional information that is related to the activated link.

The data is stored in variables &EHKVAR1 through &EHKVAR9 and &EHKVART when the ACTIVMSG and TERMMSG generic routines are called when there is a provider status change.

The maximum length of the user data is 243 characters.

Return Codes

- 0 Normal completion.
- 4 Incorrect parameter.
- 5 Other error.
- 6 Initialization of the automation environment is not complete.
- 8 The link is not defined in the policy.

Restrictions and Limitations

Static and dynamic links can be defined in the policy between consumer and provider applications that are running on the same system.

The ACTIVATE function requires fully-qualified consumer and provider names, that is, the names cannot contain any wildcards.

The DEACTIVATE function requires a fully-qualified consumer name (that is, the name cannot contain any wildcards) and a fully-qualified provider name or an asterisk to refer to all providers.

Instead of using subsystem names, job names can also be used for the ACTIVATE and DEACTIVATE actions. INGLINK looks for a matching subsystem name first. If no matching subsystem name is found, it looks for a job name.

The LIST function allows wildcard names as consumer or provider names. Job names cannot be used.

INGLINK maintains the status of links based on common global variables. Access to these variables is made through the consumer's work operator in order to guarantee serialized exclusive access.

Usage

There are static and dynamic links that can be defined in the SA z/OS Customization Dialog. There you can define pseudo-messages in the MESSAGES/USER DATA policy of the consumer application with the prefix UP_ or DN_, followed by the provider subsystem name (for example, UP_TCPIP). You can define a command action for these messages that is executed when the provider enters an UP or DOWN state. No additional definitions are required for the provider application.

For static links, no further definitions are required for the consumer application. Using INGLINK LIST you can list any static links. Static links are always active links. Thus INGLINK ACTIVATE or INGLINK DEACTIVATE cannot be used for static links.

For dynamic links, a USER action must be applied to the pseudo-messages in the MESSAGES/USER DATA policy by setting the keyword to DYNAMIC and the value to YES. Dynamic links are initially inactive. These links can be activated with INGLINK ACTIVATE and deactivated with INGLINK DEACTIVATE. Dynamic links have the advantage that they can be activated and deactivated at run time. This may be necessary if a consumer requires services that can only be determined at run time.

Typically a user routine is required to identify the current provider. After the provider has been determined, INGLINK ACTIVATE can be called from the user routine to activate the link to that provider. A configured action can be taken by the consumer if a provider starts or terminates only when a link is active.

The user routine is typically started along with the consumer application.

Examples

Example 1:

Activating a dynamic link that is in an 'inactive' state:

```
INGLINK ACT MQ TCPIP1 optional user data
```

Console Output: ING004I REQUEST >INGLINK ACTIVATE< SUBMITTED

Log Output: A0F367I LINK ACTIVATED BETWEEN MQ AND TCPIP1

Example 2:

Deactivating a dynamic link that is in an 'active' state:

```
INGLINK DEACT MQ TCPIP1
```

Console Output: ING004I REQUEST >INGLINK DEACTIVATE< SUBMITTED

Log Output: A0F368I LINK DEACTIVATED BETWEEN MQ AND TCPIP1

You can list all links with the following command:

```
INGLINK LIST * *
```

The output lists all dynamic and static links that are defined in the automation policy.

INGLINK

CONSUMER	PROVIDER	UP LINK	DOWN LINK	PARAMETERS
APL1	VTAM	STATIC	STATIC	
APL2	VTAM	STATIC	STATIC	
MQ	TCPIP1	ACTIVE	ACTIVE	PARM1 PARM2
MQ	TCPIP2	INACTIVE	ACTIVE	

INGMTRAP

Purpose

The INGMTRAP command facilitates the use of INGOMX for OMEGAMON exception monitoring using Monitor Resources. It traps one or more OMEGAMON exceptions of interest and generates ING080I messages exposed to automation for each exception that is found, in order to set the Monitor Resource's health state and to issue commands to react to such exceptional conditions.

Syntax

```
➤—INGMTRAP—NAME=session_name—XTYPE=(exception)—➤
```

Parameters

NAME=*session_name*

This is the name of the OMEGAMON session as defined in the automation policy that exceptions should be monitored from.

XTYPE=*exception_list* | *exception*

A list of one or more OMEGAMON exceptions. If the list consists of more than one exception, it must be put in quotes or parentheses, and either commas or blanks must be used to separate the exceptions.

Return Codes

1 BROKEN

INGMTRAP failed to communicate with the OMEGAMON monitor denoted by the *session_name*. Either SA z/OS was unable to create the session, or the session was prematurely terminated for other reasons and could not be re-established. In general, whenever the state of a session is neither INACTIVE nor ACTIVE, the health status BROKEN indicates that operator intervention is required.

2 FAILED

INGOMX detected that the session denoted by *session_name* exists but no output was received by OMEGAMON, for example due to a timeout. This situation may go before the monitor runs the next time. In general, whenever the state of a session is ACTIVE, the health status FAILED indicates a temporary problem that is likely solved the next time the monitor runs.

3 NORMAL

No exceptions have tripped. The health state of this Monitor Resource is therefore normal. Message ING081I was built and added to the Monitor Resource's history to indicate that no exception was found. ING081I will not be exposed to automation.

8 DEFER

Exceptions have tripped and message ING080I was built for each. The health state of the Monitor Resource will be set on behalf of message automation for ING080I when the message is processed by the automation table. An existing health state remains in effect until a new health state is set during message automation.

Usage

To monitor OMEGAMON exceptions with a Monitor Resource, specify INGMTRAP as the monitor command in the customization dialog when defining the Monitor Resource. INGMTRAP will generate an ING080I message for each exception that tripped and that was specified with XTYPE and exposes the message to automation.

In order to react to such exceptions, use the MESSAGES/USER DATA policy item for that Monitor Resource to specify the health status and optionally the recovery activities for each exception. As indicated by the return code DEFER, the health status of the Monitor Resource will only be updated if an ING080I message was correctly processed.

Example

To monitor the existence of a LOGN exception that is issued by OMEGAMON for DB2 whenever the number of primary active logs falls below the installation-specified threshold, enter the following as a monitor command in the MTR policy:

```
INGMTRAP NAME=OMSY4DB XTYPE=LOGN
```

INGOMX

Purpose

INGOMX is a programming interface that provides interaction capabilities with OMEGAMON. It allows a program or command list to invoke OMEGAMON exception analysis in order to trap one or more exceptions of interest or to issue one or more OMEGAMON commands. The response generated by OMEGAMON on behalf of a request is written to the console but not exposed to automation.

Additionally, it provides an interface to communicate with an IBM Tivoli Monitoring SOAP server to issue SOAP messages and to process the response from the SOAP server. While INGOMX handles the communication and the envelope of the SOAP message, it is the responsibility of the caller to provide an appropriate body either dynamically or in a data set of choice. The body consists of specific elements in XML notation that denote the particular request, the target application for this request, user ID and password, and other request-specific information.

Syntax

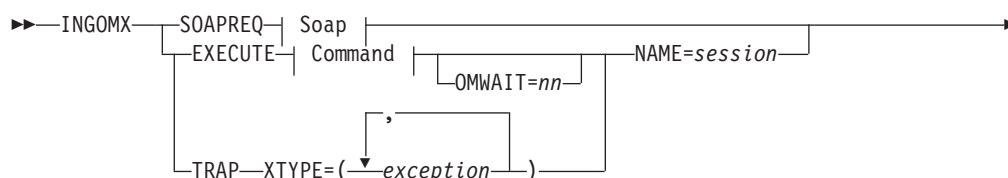



Soap:

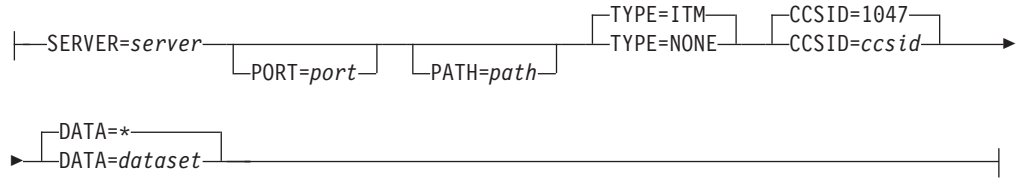

Command:

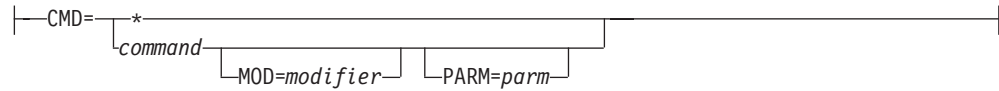

Parameters

SOAPREQ

The function code to send a SOAP message to the SOAP server designated by *server*. The SOAP message to be sent can be built dynamically and passed to INGOMX through the default safe or it can be in a user-defined dataset.

SERVER=server

server refers to the SOAP server defined in the SOAP SERVER policy of the NETWORK (NTW) entry in the automation policy.

Alternatively, *server* can be the IP-address (if it starts with a digit or contains ':') or the symbolic host name. If a SOAP SERVER policy is found for *server*, it will be used preferably.

PORT=port

port refers to the port number that the SOAP server is listening to. This is optional and only required if *server* does not denote a definition in the SOAP SERVER policy.

PATH=path

path refers to the absolute path that, together with the host address and the port number, forms the address of the SOAP service. An absolute path must start with a slash ('/'). This is optional and only required if *server* does not denote a definition in the SOAP SERVER policy.

TYPE={ITM | NONE}

The type refers to the kind of SOAP request that is being issued. For ITM type SOAP requests, the response document is transformed into messages that can be processed further using NetView PIPES. For other SOAP requests, the response is returned in XML format instead.

CCSID=ccsid

ccsid refers to the character set identifier used to encode the XML source and target documents. The SOAP request is translated from *ccsid* to UTF-8 before it is sent to the SOAP server and it is translated back to *ccsid* upon receipt.

DATA={* | dataset}

If * is specified, the SOAP message is located in the default SAFE. This

assumes that the caller has either created the SOAP message dynamically or obtained it from some other source and passed it to INGOMX via a PIPE input stream. See also “Example 3: Send SOAP Message Using the Default Safe” on page 149.

dataset refers to the name of either a sequential data set or a partitioned data set, including the member name where INGOMX finds the SOAP message.

EXECUTE

The function code to issue a command to the OMEGAMON session that is specified by *session_name*. The command and its parameters are specified by the CMD, MOD, and PARM keywords. The output of this command corresponds to the output produced by the OMEGAMON monitor on a 3270 screen.

CMD={*command* | *}

This is the pure 1 to 4 character OMEGAMON command that is issued on the OMEGAMON session without parameters.

If an asterisk (*) is passed instead of a command, INGOMX expects a list of up to 22 OMEGAMON commands in the default SAFE. This allows a programmer to issue multiple commands at once, in particular, minor commands that require the presence of an appropriate major command.

When commands are passed within the default SAFE, the same syntax rules apply as denoted in the syntax diagram above, that is, each command is specified with the CMD keyword followed by an optional modifier and optional parameter string.

The command that is specified or the first command in the default SAFE will be logged in the NetView log with message ING083I.

MOD=*modifier*

modifier is an optional additional character that will be inserted by SA z/OS in front of a command to modify the behavior of that command. For example, a '<' modifies the command ALLJ such that instead of one line of address spaces, all address spaces are returned at once. Refer to the OMEGAMON command manual for a reference of modifiers allowed for each particular command. The default modifier is a blank character.

PARM=*parm*

parm is an optional parameter string of up to 74 characters. The parameter string will be appended by SA z/OS to the command, if specified. The default parameter is a NULL-string.

OMWAIT=*nn*

Several OMEGAMON commands begin a process that accumulates data over a small period of time. For example, the OMEGAMON for MVS command MCPU accumulates data about CPU status, and then displays this data. To mimic this functionality, OMWAIT can be used, where *nn* is the optional time during which data is accumulated before the command is issued again, and can be between 0 and 59 seconds. The default wait time is 0.

TRAP

This is the function code to filter exceptions that are reported by the OMEGAMON session specified by *session*. The exceptions that should be filtered are specified by the XTYPE keyword. The output of this command

corresponds to filtered output produced by the OMEGAMON monitor exception analysis on a 3270 screen, where only the selected exceptions are included.

XTYPE={*exception_list* | *exception*}

A list of one or more OMEGAMON exceptions. If the list consists of more than one exception, it must be put in quotes or parentheses, and either commas or blanks used to separate the exceptions.

NAME=*session*

This is the name of the OMEGAMON session as defined in the automation policy.

WAIT={**YES** | *nnn*}

This parameter determines the interval after which a request is terminated with a timeout condition.

If WAIT=YES is specified (default), either the default wait time is used as a timeout value (WAITTIME) or, for OMEGAMON sessions, the timeout that is specified in the OMEGAMON SESSION policy. The parameter default variable INGOMX_WAIT can be used to override the default value in WAITTIME.

If WAIT=*nnn* is specified, *nnn* denotes a positive number in units of seconds.

Return Codes

- 0 Normal completion. The filtered output of the exception analysis or the response of the OMEGAMON command or the SOAP request, respectively, is written to the console.
- 3 The operator invoking INGOMX is not authorized to issue this request for any of the following reasons::
 - The caller is not allowed to access the session indicated by *session_name*
 - The caller is not allowed to issue the OMEGAMON command (or commands) specified by CMD
 - The caller is not allowed to send the SOAP message to the SOAP server indicated by *server_name*

Update the NetView command authorization table or the RACF definitions, or both, for the named session, the named SOAP server, and command (or commands).

NetView issues BNH236E and BNH237E with detailed error information.
- 1 INGOMX failed to communicate with the session whose *session_name* was passed as input. The *session_name* is unknown or does not refer to a valid OMEGAMON session. In case of an invalid OMEGAMON session, message ING084I is written to the netlog.

If the target was a SOAP server, the *server_name* is unknown or does not refer to a host that can be reached through the IP network. Refer to message ING164I for further diagnostic details in the netlog.
- 3 An internal error occurred. Message ING084I is written to the netlog and provides more detailed error information.
- 4 Syntax error. Invalid parameters were passed to INGOMX. Refer to the netlog for additional error information.
- 5 Timeout occurred. The requested operation was interrupted due to a timeout as specified for this session in the customization dialog. The timeout value might be too low or more session operators might be required.

- 6 The command environment for INGOMX was not appropriately initialized at the time this command was issued. Possible reasons are that the agent is currently being initialized or a cold start of the automation control file is being done.
- 7 Creation of the NetView Terminal Access Facility (TAF) session failed or VTAM is not available. Message ING084I is written to the netlog and provides more detailed error information.
- 8 The user ID that is specified in the session definition for *session_name* cannot log on to OMEGAMON. Session creation failed.
- 9 The requested function is not allowed within the current session state. Refer to the INGSESS command (in *IBM Tivoli System Automation for z/OS Operator's Commands*) for the current state and available options.
- 10 A SOAP request could be delivered, but the SOAP server failed to interpret the request correctly. Messages ING162I and ING163I are returned to the caller for further information about this failure.
- 11 A SOAP request could not be delivered to the SOAP server because the service has been moved to a new location. Message ING167I is returned to the caller indicating the new location that must be used instead.
- 12 The specified data set containing the SOAP request could not be allocated or read. Message ING164I is written to the netlog indicating the code returned from PIPE QSAM.
- 13 The specified CCSID does not exist. Specify a valid CCSID.

Usage

Invoke INGOMX in a PIPE to capture and further analyze the output produced by OMEGAMON. Alternatively, INGOMX can also be called directly from the operator console, but note that INGOMX does not issue any confirmation messages and that output is only written to the console when INGOMX returned with code 0.

Refer to "Controlling Access to IBM Tivoli Monitoring Products" in *IBM Tivoli System Automation for z/OS Planning and Installation* for Command Authorization Table identifiers supported by INGOMX.

Examples

Example 1: Use of INGOMX in a User-Written Monitor Command Routine

The following command list is specified as the monitor command that is periodically invoked to find out the usage of CSA and SQA below 16MB monitored by OMEGAMON for MVS. The session was defined under the session name OMSY4MVS. The OMEGAMON command for this purpose is "CSAA." The monitor command will return the following health states:

- NORMAL (3) when the utilization of both CSA and SQA is below 50%
- WARNING (4) when the utilization is below 70%
- MINOR (5) if below 80%
- CRITICAL (6) if below 90%
- FATAL (7) otherwise

```
/*-----*/
/* Constants and variables */
/*-----*/
```

INGOMX

```
Rc_Unknown = 0
Rc_Failed  = 2
Rc_Normal  = 3
Rc_Warning = 4
Rc_Minor   = 5
Rc_Critical = 6
Rc_Fatal   = 7

health_state = Rc_Unknown
lrc = 0

ss='ff'x
ec='fe'x
dc='fd'x
/*-----*/
/* Use PIPE to call INGOMX */
/*-----*/
"PIPE (STAGESEP "||ss||" END "||ec||" NAME API)",
  " NETV (MOE) INGOMX EX,NAME=OMSY4MVS,CMD=CSAA",
  ss|"A: LOCATE 1.8 /DW0369I /",
  ss|" VAR dwo369",
  ec|"A: ",
  ss|" STEM output."

/*-----*/
/* Monitor failed if INGOMX return code was not zero */
/*-----*/
if symbol('dwo369') = 'VAR' then
  do
    parse var dwo369 . 'RETURN CODE' lrc '.'
    monmsg = 'INGOMX return code was RC='lrc+0
    health_state = Rc_Failed
  end
else
/*-----*/
/* Filter CSA and SQA percentages to derive health state */
/*-----*/
  do
    csa = 0; sqa = 0
    do i=1 to output.0
      if pos('+ CSA',output.i) > 0 then
        parse var output.i . 'CSA' . . . . csa '%' .
      if pos('+ SQA',output.i) > 0 then
        parse var output.i . 'SQA' . . . . sqa '%' .
      end i
    select
      when csa < 50 & sqa < 50 then health_state = Rc_Normal
      when csa < 70 & sqa < 70 then health_state = Rc_Warning
      when csa < 80 & sqa < 80 then health_state = Rc_Minor
      when csa < 90 & sqa < 90 then health_state = Rc_Critical
      otherwise
        health_state = Rc_Fatal
    end
    monmsg = 'CSA usage is 'csa+0'%, SQA usage is 'sqa+0'%.'
  end

'PIPE VAR monmsg | CONSOLE ONLY'

Return health_state
```

Example 2: Use of INGOMX to Display Jobs of Interest

The following command list can be entered from the console to show a list of jobs that have fixed storage occupancy greater than 1 MB. The command list traps the FXFR exception that is reported by OMEGAMON for MVS with the session name OMSY4MVS. From the list of exception lines that is returned by OMEGAMON, the command list selects those jobs that obtain more than 1 MB of fixed storage.

```

/*-----*/
/* Constants and variables */
/*-----*/
OneMB = 1024 * 1024
fframes = 0 /* Number of fixed frames */
fstor = 0 /* Fixed storage [Bytes] */
out. = 0 /* Jobs with >1MB fixed frames */
j = 0 /* Miscellaneous counter */
lrc = 0 /* Local return code */
ss = 'ff'x
ec = 'fe'x

/*-----*/
/* Use PIPE to call INGOMX */
/*-----*/
"PIPE (STAGESEP "||ss||" END "||ec||" NAME API)",
" NETV (MOE) INGOMX TRAP,NAME=OMSY4MVS,XTYPE=FXFR",
ss | "A: LOCATE 1.8 /DWO369I /",
ss | " VAR dwo369",
ec | "A: ",
ss | " STEM output."
/*-----*/
/* Command failed if INGOMX return code was not zero */
/*-----*/
if symbol('dwo369') = 'VAR' then
do
parse var dwo369 . 'RETURN CODE' lrc '.'
'MESSAGE DSI072 FXSHOW INGOMX 'lrc+0
end
else
/*-----*/
/* Produce list of address spaces with >1MB fixed frames */
/* + FXFR STC NETVBDO | Fixed Frames in use = 414 */
/*-----*/
do
out.1 = 'FXMON: Jobs with fixed storage > 1MB'
out.0 = 1
do i=2 to output.0
parse var output.i '+ FXFR' . job . 'Frames in use = 'fframes .
fstor = fframes * 4096
if fstor > OneMB then
do
j = out.0 + 1
out.j = left(job,8) format(fstor/OneMB,4,2)||'MB'
out.0 = j
end
end i

'PIPE STEM out. | CONSOLE ONLY'
end

Exit 0

```

Example 3: Send SOAP Message Using the Default Safe

This example assumes that the SOAP server SOAPHUB was defined in the SA z/OS customization dialog SOAP SERVER policy. To request a list of address spaces starting with TEST and analyze their CPU utilization, you can construct and send a SOAP message like the one below to SOAPHUB in the following way:

```

| msg.1 = '<CT_Get>'
| msg.2 = ' <object>Address_Space_CPU_Utilization</object>'
| msg.3 = ' <attribute>job_name</attribute>'
| msg.4 = ' <attribute>asid</attribute>'
| msg.5 = ' <attribute>tcb_percent</attribute>'
| msg.6 = ' <afilter>Job_Name;LIKE;TEST*</afilter>'
| msg.7 = '</CT_Get>'
| msg.0 = 7

```

```
'PIPE (NAME SOAPREQ)',
'| STEM smgs.',
'| SAFE *',
'| NETV INGOMX SOAPREQ SERVER=SOAPHUB DATA=*
```

Example 4: Send SOAP Message Using a Data Set

As an alternative, the XML source in “Example 3: Send SOAP Message Using the Default Safe” on page 149 can also be stored in a data set. The invocation of INGOMX would then be:

```
'PIPE (END % NAME SOAPREQ)',
'| NETV (MOE) INGOMX SOAPREQ SERVER=SOAPHUB DATA=USER.SOAP.DATA(GET)',
'| L: LOC 1.8 'del' 'DW0369I ' 'del',
'| EDIT SKIPTO 'del' 'RETURN CODE' 'del',
'| UPTO 'del' '.' 'del',
'| WORD 3 1',
'| VAR my_retcode',
'| % L:',
'| CON ONLY'
```

The variable *del* is a delimiter character that does not appear in the data stream that is returned, for example, X'0D'.

Example 5: Explicit Specification of SOAP Server

Here an example is shown where the SOAP server is not defined in a SOAP server policy but directly in the invocation of INGOMX:

```
Server = 'boekeya.boeblingen.de.ibm.com'
Path = '///cms/soap'

Address Netvasis 'PIPE (END % NAME SOAPREQ)',
'| NETVASIS NETV (MOE) INGOMX SOAPREQ SERVER='Server,
'| PORT=1920 PATH="'Path'" DATA=USER.SOAP.DATA(GET)',
'| L: LOC 1.8 'del' 'DW0369I ' 'del',
'| EDIT SKIPTO 'del' 'RETURN CODE' 'del',
'| UPTO 'del' '.' 'del',
'| WORD 3 1',
'| VAR my_retcode',
'| % L:',
'| CON ONLY'
```

Note that the path is passed in double-quotes to preserve its case.

INGSIT

Purpose

The INGSIT command allows you to report an event to SA z/OS. To allow SA z/OS to react to that event, it must be associated with one or more Monitor Resources through the monitored object name and optionally a job name. Refer to *IBM Tivoli System Automation for z/OS Customizing and Programming* for a description of Monitor Resources and the concept of a monitored object.

The event information consists of the monitored object name, an optional event severity, an optional job name, and optional related data. INGSIT transforms the event into a well-formed ING150I message that can subsequently be automated on behalf of the monitored object according to the definitions in the automation policy.

Syntax

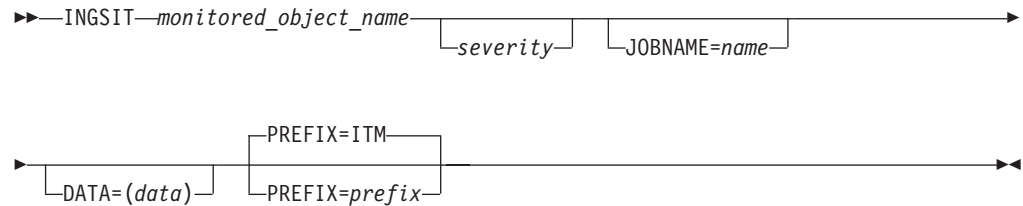

Parameters

monitored_object_name

This is the name of the monitored object without the prefix associated with one or more Monitor Resources. To report IBM Tivoli Monitoring situations to SA z/OS (for example, from OMEGAMON XE for z/OS) use the situation as the monitored object and specify its name *in uppercase* with a prefix of ITM in the MONITOR INFO policy when defining the Monitor Resource.

The monitored object name, including the prefix, can be up to 50 characters long and consist of any character except any of the following characters: ' " , () = ? * and blanks. The monitored object name is case-sensitive.

severity

This is the severity associated with the event. If it is omitted, the text string WARNING is used as the default severity. To report IBM Tivoli Monitoring situations to SA z/OS (for example, from OMEGAMON XE for z/OS) you can use the alert severity that was optionally assigned to the situation or any other severity string if the default does not meet your requirements.

When processing message ING150I via the NetView Automation Table, the severity string is passed as the CODE1 parameter to the INGMON generic monitoring routine. If you want to map this severity to a health status, you have to ensure that there is a matching CODE entry in the MESSAGES/USER DATA policy for message ING150I. The health status, if any, is specified as the second word in the value returned for that CODE.

If there are several different severities for the same monitored object and you want to react in different ways to such an event, you also have to ensure that there is a matching CODE entry in the MESSAGES/USER DATA policy for message ING150I. The first word in the value returned is then treated as the command selection. Alternatively, return a # to perform PASS processing for ING150I, or #*usermsg* to perform independent PASS processing for the message entry, *usermsg*.

Refer to *IBM Tivoli System Automation for z/OS Customizing and Programming* for examples of how to set up your automation policy to react to message ING150I as described.

JOBNAME=name

This is an optional job name. If it is specified, it is compared with the job name specified for a monitored object to match this situation to a particular monitor resource. If a job name is not passed, the event reported through this invocation of INGSIT may only match monitor resources that are defined without a job name.

DATA=(data)

This is an optional string of additional information that is related to the event. The parentheses are required if you want to pass a string that contains blanks

INGSIT

or commas. For a single word, the parentheses can be omitted. *data* is appended to message ING150I without further analysis to be used for any optional user-specified purposes by the automation.

PREFIX=prefix

This is the prefix followed by a period that precedes the specified *monitored_object_name*. The default prefix is ITM. The monitored object name appear in message ING150I as: *prefix.monitored_object_name*

Return Codes

- 0 Normal completion.
- 1 Syntax error. Invalid parameters were passed to INGSIT. Refer to the netlog for additional error information.
- 2 The command environment for INGSIT was not appropriately initialized at the time that this command was issued. Possible reasons are that the agent is currently being initialized or a cold start of the automation control file is being performed.

Restrictions and Limitations

For situations, monitored object names *cannot* be distinguished by case. The situation *must* be specified as monitored object in uppercase in the MONITOR INFO policy.

Usage

The ING150I message that is generated as a result of the event transformation may or may not cause an automated response. If a monitored object was specified but a Monitor Resource was not found for it, no automation is triggered.

The health status of a Monitor Resource that matches the monitored object name is not changed unless you map the severity (either your own input or the default of WARNING) explicitly to a health status using a CODE entry in the MESSAGES/USER DATA policy for message ING150I.

Examples

Example 1: Using the Default Severity

The following example reports the situation OS390_Local_PageDS_PctFull_Warn to SA z/OS. A default severity of WARNING is used and the related data passed to SA z/OS is substituted from the page data set utilization attribute, which here is 25%.

```
INGSIT OS390_LOCAL_PAGEDS_PCTFULL_WARN DATA=(25)
```

This yields:

```
ING150I 09:34:37 08/01/2007 : ITM.OS390_LOCAL_PAGEDS_PCTFULL_WARN  
WARNING N/A DATA= 25
```

Example 2: Using an Explicit Severity

The following example reports the situation OS390_PageDSNotOperational_Warn to SA z/OS. The severity, although it indicates a warning-level situation, is reported as minor and the count of non-operational data sets is passed as the related data, which here is 1.

```
INGSIT OS390_PAGEDSNOPERATIONAL_WARN Minor Data=1
```

This yields:

```
ING150I 09:35:42 08/01/2007 : ITM.OS390_PAGEDSNOPERATIONAL_WARN
MINOR N/A DATA= 1
```

INGSTOBS

Purpose

The INGSTOBS routine lets you subscribe as a status observer for one or more resources. Whenever a status change occurs, the automation manager sends you a notification. The following statuses are applicable:

Observed

Is the current status of the resource monitored by the automation manager.

Desired

Is the status the resource should be in. The automation manager attempts to put the resource into this state. This is also called the 'goal' of the resource.

Automation

Is the current status of the resource within the automation process of SA z/OS.

Compound

Is the summary of all statuses and a few other indicators.

Startability

Indicates whether the resource is ready to be started when a start command is issued.

Health

Application-specific performance and health monitoring provides a separate status to inform you about the application's health.

To register as a status observer, specify the name of a REXX exit. SA z/OS invokes this exit for each status change. The following parameters are passed to the exit:

- The name of the resource, for example, TSO/APL/SYS1
- The observed status
- The automation status
- The desired status
- The compound status
- The startability status
- The health status

The parameters are separated by a comma.

Syntax

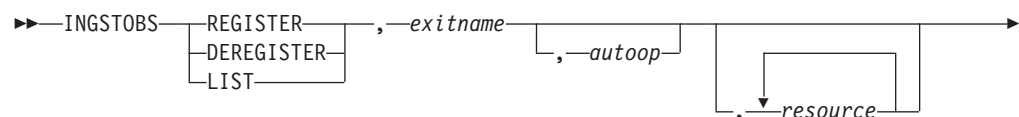



Parameters

REGISTER

Performs the subscription by linking the specified exit to each resource specified.

Each subsequent status change of the resource triggers the exit to be invoked.

DEREGISTER

Breaks the link between the exit and the resource. The exit is no longer invoked if a status change of the resource occurs.

LIST

Displays the resources that are subscribed and linked to the specified exit.

exitname

Specifies the name of the REXX exit to be invoked when a status change of the resource occurred.

autoop

The automated function that the autotask name is defined from. The exit is scheduled to run on the autotask associated with the automated function. If omitted, the exit runs on the SA z/OS task responsible for communicating with the automation manager. It is recommended to use a different task.

resource

Specifies the name of the resource or family of resources, via wildcard, for example, TSO/APL/*. The resource names must be separated by a blank. Alternatively, the list of resources can be passed to the common routine with a NetView default Pipe Safe.

The parameters must be separated by a comma.

INITNTFY

Specifies whether the automation manager sends the status change immediately:

YES

The automation manager sends the status change immediately. This causes a call to the user exit immediately.

NO

This causes the automation manager to send the status change with the next subsequent status change.

WAIT

Specifies whether to wait until the automation manager has processed the request.

YES

Wait for completion. This is the default.

NO

This causes the subscription request to be sent to the automation manager *without* waiting for its completion.

nnn

This is the number of seconds to wait before giving up and reporting that a timeout has occurred. The maximum time interval is 999 seconds. If omitted, the time interval is 30 seconds.

Restrictions and Limitations

The INGSTOBS command can only be issued for a local system.

Examples

To register TEST2 as a status observer exit for all resources starting with CICS, specify:

```
INGSTOBS REGISTER,TEST2,MSG2OPER,CICS*/APL/AOC8
```

When the exit is invoked it runs on the autotask associated with the MSG2OPER automated function:

To display the resources that are associated with the status observer exit TEST2, specify:

```
INGSTOBS LIST,TEST2
```

Figure 9 shows exits and associated resources:

Figure 9. Exits and Associated Resources

Resource	Exits...
AM SINGLE/APG/AOC1	INGRYSOS/MSGOPER
FEATEMUL/APG/AOC1	INGRYSOS/MSGOPER
MOVSYSTEM/APG/AOC1	INGRYSOS/MSGOPER
PARCHILD/APG/AOC1	INGRYSOS/MSGOPER
PBBB1/APG/AOC1	INGRYSOS/MSGOPER
PBBC1/APG/AOC1	INGRYSOS/MSGOPER
PBMA1/APG/AOC1	INGRYSOS/MSGOPER
SYSSRV1/APG/AOC1	INGRYSOS/MSGOPER
SYSSRV2/APG/AOC1	INGRYSOS/MSGOPER
*** End of Display ***	

INGSTX

Purpose

INGSTX controls user-defined status items. Status items can be defined, updated, queried, and deleted. They are stored in the status item repository within the SA z/OS automation manager.

Each status item has the following attributes that are either set or modified through INGSTX:

- STIORIGN — Status item originator. This field contains the name of the system that the status item is collected from. This field cannot be updated.
- STISTGRP — Status item group. If the status item was defined in the form of two subfields separated by a period, this is the first subfield. Otherwise, the field is empty (null string). This field cannot be updated.

INGSTX

- STISTNAM — Status item name. If the status item was defined in the form of two subfields separated by a period, this is the second subfield. Otherwise, this is the complete name that was specified when the status item was created. This field cannot be updated.
- STIVALUE — Status item's current value. An arbitrary positive or 0 integer value expressing the status item's current condition. This field can be updated.
- STIDESCR — Status item description. A textual description of the status. This field can be updated.
- STITRTXT — Status item transient user text. This field can be used to store transient user data. This field can be updated.
- STITCHNG — Status item change time. The format of this field is: CYYMMDDHHMMSSmmm. This field is updated by SA z/OS when a status time was set the last time. Format = GMT.
- STIPERST — Status item persistency. This field is set upon first mention of this status item. A value of 1 means it is persistent; 0 means it is non-persistent.

Syntax

To define or update a status item, use the following syntax:

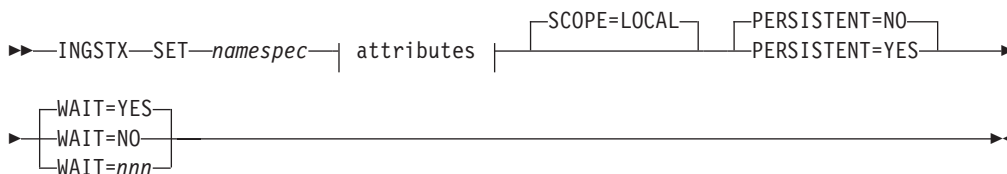

attributes:

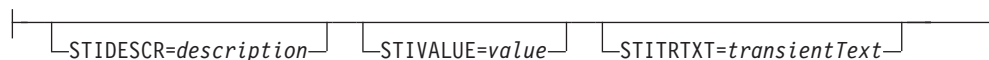

To query a status item, use the following syntax:



To delete a status item, use the following syntax:

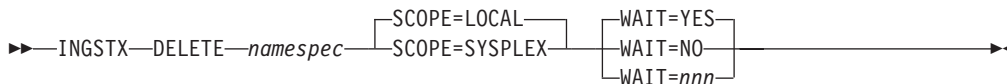

Parameters

SET

This is the function code to define or update a status item. A status item is defined implicitly upon the first mention of the item name. At definition time, you can determine whether the status item should be persistent across SA z/OS sessions or even across IPLs. The `PERSISTENT` keyword is ignored on subsequent updates of the same status item.

QUERY

This is the function code to query one or more status items that match the pattern denoted by *namespec*. The status item attribute values are positional and are returned in the following format (all on one line):

```
STIORIGN<del>STISTGRP<del>STISTNAM<del>STIVALUE<del>STIDESCR
<del>STITRTEXT<del>STITCHNG<del>STEPPERST<del>
```

where is a non-ambiguous delimiter character. For an attribute that has not been specified, a null string is returned, that is, . STISTGRP is the first substring, if any, of the status item name, and STISTNAM is the remainder, if any, excluding the period.

 is the character □, which represents 0xFF.

DELETE

This is the function code to delete one or more status items that match the pattern denoted by *namespec*.

namespec

This is either the complete specification of a status item or a specification pattern using the asterisk (*) wildcard character.

Each status item has a system scope. To enable grouping of status items, the name can be divided into two substrings separated by a period (.). For each substring, only alphanumeric characters and the national characters \$, &, and # are allowed. The second substring can contain additional periods for readability purposes. The first character must not be a period or a numeric character. Its maximum length cannot exceed 32 characters.

When a wildcard is used, it can be specified at the beginning or at the end of each substring. The following are examples of valid *namespecs*:

- CICSREGA.MAXTASKS
- CICS*.MAX*
- *.MAX*
- JOB*

Status item names are case-sensitive.

attributes

Each status item has a set of optional attributes. They are specified in *attribute=value* pairs. If the value is a string that contains blanks, or you want to preserve the case of the characters, enclose value in single or double quotes.

Valid attributes are:

STIDESCR=*description*

A textual description of the status item. The maximum length is 32 characters. Basically, all readable characters are allowed.

STITRTEXT=*transientText*

User-specific text that provides further details about the status item's value. The maximum length is 128 characters. Basically, all readable characters are allowed.

STIVALUE=*value*

An arbitrary 4-byte positive or 0 (zero) integer value of the status item, up to 2,147,483,647. If not specified, the default is set to 0.

SCOPE

This keyword indicates whether the request that is specified addresses status

items from the local system only or from all systems in the sysplex (more specifically, all systems connected to the automation manager's XCF group).

SCOPE=LOCAL

Only status items bound to the local system are addressed. This is the default.

SCOPE=SYSPLEX

Status items from all systems in the same sysplex are addressed. This scope is not allowed for SET requests.

WAIT

This keyword indicates whether the request is executed synchronously or asynchronously and, if synchronously, how long the caller is willing to wait for an answer. A request will be discarded if the default or user-specified wait time expires.

Note: This parameter is always either YES or a time period for QUERY requests.

WAIT=YES

The request is executed synchronously, that is, the caller regains control only when the request has been processed by the automation manager, either completely or after waiting for more than 30 seconds. If the request could not be processed within this time, it is discarded. This is the default option.

WAIT=NO

The request is executed asynchronously, that is, the caller regains control immediately after the request was accepted by the automation manager. The automation manager executes the request in the background.

WAIT=nnn

This option is similar to WAIT=YES with the difference that the maximum time the caller waits for the request to complete is specified as *nnn* seconds. Specify any value between 1 and 999 seconds.

PERSISTENT

A status item can be defined as persistent to live across SA z/OS sessions or IPLs. Non-persistent status items are implicitly removed from the status item repository in the SA z/OS automation manager upon disconnecting a system from the sysplex XCF group.

PERSISTENT=NO

Status item is non-persistent. This is the default.

PERSISTENT=YES

Status item is persistent.

Return Codes

The following return codes are passed back upon completion of INGSTX:

- 0 Normal completion.
- 3 The operator that invoked INGSTX is not authorized to set, query, or delete a status item.
- 1 Keyword PERSISTENT was specified for an update request of an existing status item. It is ignored.
- 2 Function QUERY or DELETE was specified but no status item was found in the status item repository that matches the given *namespec*.

- 3 The request could not be processed successfully by the automation manager. Refer to the NETLOG for additional error information.
- 4 Syntax error. Invalid parameters were passed to INGSTX. Refer to the NETLOG for additional error information.
- 6 The command environment for INGSTX was not appropriately initialized at the time this command was issued. Possible reasons are that the SA z/OS agent is currently being initialized or a cold start of the automation control file is being done.
- 7 INGSTX failed to create a system resource list for requests with SCOPE=SYSPLEX. Refer to the NETLOG for additional error information.

Examples

Example 1

To define two new non-persistent status items called CSA and ECSA, specify:

```
INGSTX SET CSA stidescr="CSA Below" stivalue=0
           stitrxt="Utilization 10%"
```

```
INGSTX SET ECSA stidescr="CSA Above" stivalue=0
           stitrxt="Utilization 12%"
```

Example 2

To update the status item CSA that was defined in the previous example, specify:

```
INGSTX SET CSA stivalue=10 stitrxt="Utilization 31%"
```

Example 3

To query all status items on the local system that end with the three letters CSA, specify:

```
INGSTX QUERY *CSA
```

For the status items defined in examples 1 and 2, output similar to that shown below is returned:

```
SYS1  CSA  10  CSA Below  Utilization 31%  1060203100659000  0
SYS1  ECSA  0  CSA Above  Utilization 12%  1060203100105000  0
```

Example 4

To delete all status items that originated on the local system, specify:

```
INGSTX DELETE *
```

INGTIMER

Purpose

The INGTIMER command links NetView timer commands to subsystems. This means that the timer is only active when the subsystem is active. When the subsystem terminates, the timer commands are automatically purged. To deactivate the timers at SHUTINIT time, the INGTIMER subsystem PURGE command can be specified as a SHUTINIT command.

Syntax

INGTIMER

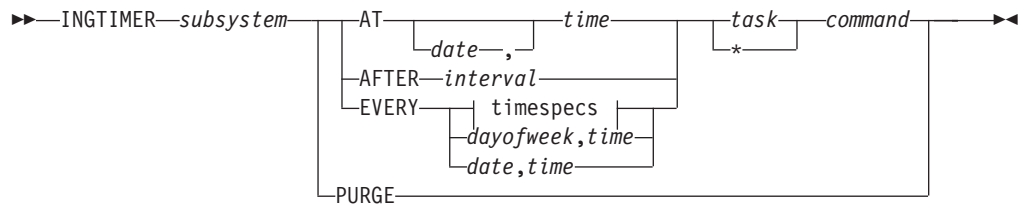

timespecs:

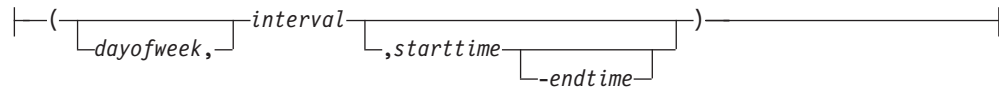

Parameters

subsystem

Specifies the name of the subsystem.

AT

Specifies the start time of the command.

AFTER

Specifies the time interval that must elapse after the subsystem became active. When this time interval has elapsed, the command is run. For example, if the subsystem becomes active at 12:00 am and you specify 2 hours, the command runs at 2:00 pm.

EVERY

Specifies the times when the command is to be repeated between the start time and end time.

PURGE

Specifies that all timers associated with the subsystem are purged.

date

Specifies the date, in mm/dd/yy format, that the command should run on. You can specify one or more Xs for the year or both the year and month. The command will then run at the next month or year increment. For example:

```
mm/dd/XX07
mm/dd/XXX8
Xm/dd/XXXX
XX/dd/XXXX
```

time

Specifies the time that the command is to run at. The format is hh[:mm[:ss]]. Instead of entering digits, one or more Xs can be specified at the beginning. If the time begins with an X or multiple Xs instead of a number, the command is set to begin at the next increment of time.

interval

Specifies the time interval that is to elapse before the command is run. The format is hh[:mm[:ss]]. Minutes and seconds are optional values.

starttime

Specifies the start time of the command, which is when it is to be run for the first time. The format is hh[:mm[:ss]]. Minutes and seconds are optional values. The specified time can be earlier than the current time. The command is then run at the next regular interval after the current time, with intervals calculated

based on the start time. If the time begins with an X or multiple Xs instead of a number, the command is set to begin at the next time increment.

endtime

Specifies the time when the interval is to end. The format is hh[:mm[:ss]]. Minutes and seconds are optional values. Applies only when the interval is shorter than 24 hours.

dayofweek

Specifies the day of the week when the timer command should run. Specify MON through SUN, WEEKDAY, WEEKEND, or ALL.

task

Specifies the operator from whose user ID the command is to be executed. It can also be an automated function. The default is the work operator associated with the subsystem. The timer itself runs on the PPT task.

- * Is a placeholder that indicates that the default is used. The default is the work operator associated with the subsystem.

command

Specifies which command is to be issued when the timer expires.

All timers are converted to the NetView CHRON command format. Thus, daylight-saving-time switching is supported. The timer runs on the PPT task.

Note: Storing the timer in the NetView save/restore database is pointless because the timer is only active while the subsystem is in an UP state.

Restrictions and Limitations

None.

Usage

To link a timer to a subsystem, you have to register the NetView timer command as follows:

- At subsystem post-start time. This associates the timer command with the subsystem and activates the timer.
- Whenever NetView is restarted (use ACORESTART). This activates the timer command again.

The timers are only in effect when the subsystem that they are defined for is active. This is useful for applications that can be moved within the sysplex.

Examples

To issue a command that should run every 30 minutes between 10:00 am and 2:00 pm, specify the following:

```
INGTIMER TSO EVERY (00:30,10:00-14:00) * F MVS &SUBSJOB,GETLSEQ
```

To issue a command that should run 10 minutes after a certain subsystem became available, specify the following:

```
INGTIMER &SUBSAPPL AFTER 00:10 * MSG,ALL Subsystem is now active
```

To issue a command that should run each Friday at 5:00 pm, specify the following:

```
INGTIMER &SUBSSYS EVERY FRI,17:00 PPT MVS D T
```

INGVARS

Purpose

The INGVARS command is the interface for you to either get or set a shared variable. The shared variable can be associated with an application resource, a system or the sysplex itself.

Syntax

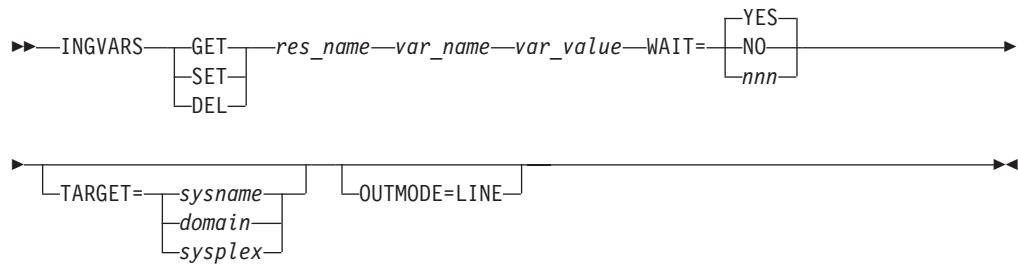

Parameters

GET

Obtains the shared variables.

SET

Sets the shared variable. Passing a null string resets the variable.

DEL

Deletes the variable.

res_name

The name of the resource in automation manager format, for example, TSO/APL/AOC8. A wildcard can be specified.

var_name

The name of the variable. Maximum length is 32 bytes. Can be a wildcard, for example, abc*, *abc or *abc*. The variable name cannot contain a comma.

var_value

The value of the variable. Only applicable for the SET function. The value can contain embedded blanks or a keyword/value pair. The value is stored in character format.

WAIT

Specifies whether to wait until the automation manager has processed the request.

YES

Wait for completion. This is the default.

NO

This causes the subscription request to be sent to the automation manager *without* waiting for its completion.

nnn

This is the number of seconds to wait before giving up and reporting that a timeout has occurred. The maximum time interval is 999 seconds. If omitted, the time interval is 30 seconds.

TARGET

For information on the TARGET parameter, refer to *IBM Tivoli System Automation for z/OS Operator's Commands*.

OUTMODE

For information on the OUTMODE parameter, refer to *IBM Tivoli System Automation for z/OS Operator's Commands*.

Assigning shared variables to resources provides an automatic cleanup of the shared variables. If the resource that the shared variable is associated with is removed (for example, due to an INGAMS refresh), the shared variables are automatically removed as well.

The automation manager provides the following "anchor points" for a shared variable:

Application resource

TSO/APL/sysname - this can also be a group resource, for example, CICS/APG

System

Resource sysname/SYS/sysname

Sysplex

Resource SYSPLEX/GRP

Restrictions and Limitations

None.

Usage

Since the automation manager has knowledge of all resources in the sysplex and the automation manager object structures are maintained in a persistent manner, it provides an excellent base for shared variable support.

The automation manager is thus used to manage shared variables. These variables are persistent across automation manager sessions and takeovers. The shared variables are stored in the takeover file (VSAM) or, when exploiting MQ, in the MQ State queue. Only when doing a warm or cold start are the shared variables wiped out.

Examples**Line-mode Output**

Figure 10 shows the result of the GET function. The first column is the resource name, the second column is the variable name and the third column is the value of the shared variable.

```
>> ingvars get child* don* outmode=line
CHILD11/APL/AOC8      DONALD      BOEBLINGEN
CHILD31/APL/AOC8      DONALD      SMITH
CHILD31/APL/AOC8      DON         STUTTGARTERSTR
*** End of Display ***
```

Figure 10. INGVARS Command Line-Mode Output

INGVTAM

Purpose

The INGVTAM command lets you:

- Register an application with VTAM® application node recovery.
- Issue recovery commands for all applications registered with VTAM application node recovery when VTAM has restarted.
- List applications that are registered for application node recovery.
- List major nodes that are in use by applications.

Syntax

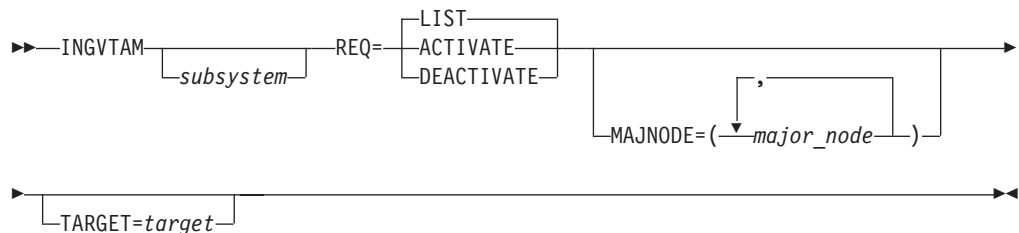

Parameters

subsystem

The subsystem parameter specifies the name of the subsystem that is registering with SA z/OS VTAM application recovery. This parameter is required with REQ=ACTIVATE to register a subsystem. If it is omitted with REQ=ACTIVATE, all subsystems currently registered will have the VTAMUP message command policy driven to allow them to take actions when VTAM is restored to active service. This parameter is required with REQ=DEACTIVATE.

REQ

Specifies the request. It can be one of the following:

LIST

If no subsystem is specified, it lists all subsystems registered for VTAM application node recovery. If a subsystem is specified, it lists all the major nodes registered for that subsystem.

ACTIVATE

If the subsystem parameter is specified, it registers the list of major nodes as specified in the MAJNODE= parameter and issues VTAM ACTIVATE commands for them. If the subsystem parameter is not specified, REQ=ACTIVATE issues the commands in the messages policy VTAMUP for every subsystem that is registered for application node recovery.

DEACTIVATE

A subsystem must be specified for this request. This request issues VTAM INACT commands for the major nodes that were previously registered. INACT commands are not issued for any major node that contains model resources or is in use by another registered application.

MAJNODE

This defines a list of VTAM application major nodes that will be acted on.

TARGET

For information on the TARGET parameter, refer to *IBM Tivoli System Automation for z/OS Operator's Commands*.

Return Codes

- 0 Normal End.
- 4 Warning (Vary command failed).
- 8 Error.

Restrictions and Limitations

To use the INGVTAM command system operations must be initialized.

Usage

It is recommended that you issue the REQ=ACTIVATE and REQ=DEACTIVATE commands on the same system as the subsystems concerned. It is recommended that you place REQ=ACTIVATE in the application's PRE-START and ACORESTART policies. However, REQ=DEACTIVATE should be placed in the application's SHUTFINAL policy. For the VTAM subsystem, the INGVTAM REQ=ACTIVATE command should be defined to the UP message policy as a command.

Examples

If you enter `INGVTAM subsystem REQ=LIST` the output looks similar to Figure 11.

Figure 11. INGVTAM REQ=LIST Output

```
List of subsystems registered with VTAM
Subsystem      Subsystem      Subsystem
EYUCMS1A
*** End of Display ***
```

To register a subsystem for application node recovery, specify, for example:
`INGVTAM &SUBSAPPL REQ=ACTIVATE MAJNODE=(IPSMBC)`

To deregister a subsystem for application node recovery, specify, for example:
`INGVTAM &SUBSAPPL REQ=DEACTIVATE`

|
| **OPER**

| The work operator that is associated with the resource.

|
| **OWNER**

| The owner information of the resource.

|
| **PARENT**

| The parent information for the resource. Parent information is derived
| from the HasParent relationship that has a sequence number assigned to it.

|
| **PATH**

| Information about the UNIX process that the resource represents.

|
| **PID**

| The USS Process ID (PID) that is associated with the resource.

|
| **PORT**

| The TCPIP port that is associated with the resource.

|
| **PROCESS**

| Contains START or STOP if the resource is within the startup or shutdown
| phase, respectively.

|
| **STAT**

| The agent status of the resource.

|
| **SUBCAT**

| The subsystem subcategory (for example, IRLM, TRACKER, TOR, AOR,
| etc.).

|
| **SUBID**

| The MVS subsystem identifier of the resource.

|
| **USER**

| The USS user ID that is associated with the resource.

|
| **WLMNAME**

| The WLM resource name that is associated with the resource.

|
| **WTOR**

| This attribute returns all outstanding reply IDs.

|
| *comp_item*

| Defines the string that the attribute value should be compared against. More
| than one compare item can be specified, separated by a blank character. The
| compare item can be a wildcard, for example, abc*

| If the attribute value matches one of the items in the compare string, the ATF
| value is set to string 'TRUE', otherwise it is set to string 'FALSE'.

| If no compare item is specified, the ING\$QRY ATF function returns the
| attribute value.

|
| *jobname*

| The name of the job that the attribute value should be returned for or
| compared against. The default is the job that issued the message.

|
| *subsys*

| The name of the subsystem that the attribute value should be returned for or
| compared against.

|
| **Restrictions**

| None.

Usage

This routine is used as a NetView Automation Table Function (ATF) within an AT condition statement to query and compare attributes of SA z/OS-controlled subsystems.

Examples

1. The following example checks whether the status of the resource that issued message WAS001I is UP and if so triggers exit AOFRIMSG:

```
IF MSGID = 'WAS001I' & ATF('ING$QRY STAT') = 'UP' THEN  
EXEC(CMD('AOFRIMSG') ROUTE(ONE *));
```

2. The following example returns the status of the resource that issued message WAS002I in variable MYVAR:

```
IF MSGID = 'WAS002I' & ATF('ING$QRY STAT') = MYVAR THEN  
EXEC(CMD('AOFRIMSG 'MYVAR) ROUTE(ONE *));
```

3. The following example checks whether the status of the resource that issued message WAS003I is either DOWN or UP. If so, it triggers exec AOFRIMSG:

```
IF MSGID = 'WAS003I' & ATF('ING$QRY STAT,DOWN UP') = 'TRUE' THEN  
EXEC(CMD('AOFRIMSG') ROUTE(ONE *));
```

4. The following example checks whether the status of job AMY0 is UP when message WAS004I is issued and if so, issues command INGLIST:

```
IF MSGID = 'WAS004I' & ATF('ING$QRY STAT,UP,JOB=AMY0') = 'TRUE' THEN  
EXEC(CMD('INGLIST AM* OUTMODE=NETLOG') ROUTE(ONE *));
```

5. The following example uses a wildcard in the compare items list. In this case it would return a list of AUTO... matches:

```
IF MSGID = 'WAS005I' & ATF('ING$QRY STAT,AU* DOWN') = 'TRUE' THEN  
EXEC(CMD('RES') ROUTE(ONE *));
```

6. The following example checks whether the subsystem is controlled by SA z/OS, assuming that the 2nd token of the message contains the job name:

```
IF MSGID = 'WAS006I' & TOKEN(2) = SVJOB & ATF('ING$QRY JOB') = VALUE(SVJOB) THEN  
EXEC(CMD('AOFRIMSG') ROUTE(ONE *));
```

Part 3. SA z/OS I/O Operations Commands

Chapter 7. I/O Operations Commands (API) . . . 173	QUERY RELATION CNTLUNIT 220
Using I/O Operations Commands for	QUERY RELATION DEV 220
Programming 173	QUERY RELATION HOST 221
Calling the I/O Operations API 173	QUERY RELATION SWITCH 222
Safe Switching 175	QUERY SWITCH 223
FICON Switches 175	REMOVE and RESTORE CHP. 226
FICON Cascaded Switches 175	REMOVE DEV and RESTORE DEV 229
Common Elements 176	WRITEFILE 235
Common Syntax Elements 176	WRITEPORT 236
Common Parameters 177	WRITESWCH 241
Common Query Commands Syntax 181	
Common Output Header 183	Chapter 8. Invoking I/O Operations with a REXX
Common Output Format 184	EXEC. 249
DELETE FILE 189	Rules for Calls by a REXX EXEC 249
QUERY ENTITY CHP 189	Literal Values 249
QUERY ENTITY CNTLUNIT 195	Optional Variables. 249
QUERY ENTITY DEV 198	Two Examples of REXX EXEC Calls 250
QUERY ENTITY HOST 200	Generalized Example of a REXX EXEC Call . . . 250
QUERY ENTITY SWITCH 203	Calling a Program that Uses the CALL Macro . . . 251
QUERY FILE 206	Calling a Program that Uses IHVAPI2 252
QUERY INTERFACE CNTLUNIT. 207	Calling a Program that Uses IHVAPI 254
QUERY INTERFACE SWITCH 212	
QUERY RELATION CHP 219	

This part describes SA z/OS I/O operations commands that are available through the API only.

For general information about the SA z/OS commands, refer to *IBM Tivoli System Automation for z/OS User's Guide*.

All commands described in *IBM Tivoli System Automation for z/OS Defining Automation Policy* are also available through the API.

Chapter 7. I/O Operations Commands (API)

Using I/O Operations Commands for Programming

In addition to the I/O operations commands described in *IBM Tivoli System Automation for z/OS Operator's Commands*, the following commands are available to programmed API calls:

- DELEte File
- Query Entity Chp
- Query Entity CntlUnit
- Query Entity Dev
- Query Entity Host
- Query Entity Switch
- Query File
- Query Interface CntlUnit
- Query Interface Switch
- Query Relation Chp
- Query Relation CntlUnit
- Query Relation Dev
- Query Relation Host
- Query Relation Switch
- Query Switch
- Remove and Restore Chp
- Remove and Restore Dev
- WRITEFILE
- WRITEPORT
- WRITESWCH

Calling the I/O Operations API

I/O operations application program interfaces support:

- Invocations from an EXEC written in the REXX programming language.
- Invocations from a user program written in a language that adheres to the Assembler Language CALL macro interface conventions used by MVS/ESA. This type of caller is referred to as a program that uses the CALL macro. For information on the CALL macro, refer to *MVS/ESA Application Development Macro Reference*. These callers can invoke IHVAPI; however IHVAPI2 is recommended.
- All variables, except arrays, data blocks, tables and tokens, must be in uppercase.
- Programs that use the CALL macro to invoke IHVAPI2 (preferred for the following reasons):
 - IHVAPI2 lets the caller choose between managing the command response area or letting I/O operations do so. IHVAPI requires the user to manage the response area.
 - IHVAPI2 can return data in a response area that exceeds 64KB; IHVAPI cannot.

Using I/O Operations Commands for Programming

– IHVAPI2 accepts all the variables needed by the I/O operations commands, including multisystem commands. IHVAPI accepts only 24-character variables as input parameters except those that specify an array, data block, or table. For those operands, it accepts a variable long enough to contain the array or table.

- Tokens
- The MVS REXX Call invocation in addition to the Address Link invocation.
- TSO/E (optional). For further information about how to invoke I/O operations by a REXX EXEC call, refer to Chapter 8, “Invoking I/O Operations with a REXX EXEC,” on page 249.

General Information About the Response Area

For most commands, I/O operations returns data to the caller in a response area.

The Data In the Response Area: When data is returned in the response area, it is either a single record or a concatenation of records in character or hexadecimal format, or both, which overlays any previous data.

For most commands, I/O operations returns at least one message in the response area. However, there are exceptions. For example, the multisystem commands can return no data, one or more messages, or a data block. Also, failed commands do not always return data in the response area.

When I/O operations returns a message, the first 3 characters are IHV, which identify I/O operations. Although the messages resulting from most commands are concatenated, up to four blank 80-character records can intervene between two successive I/O operations messages.

The Length of the Response Area: The amount of data that can be returned by a multisystem command can be very large, so the following approximate maximum lengths are provided.

For DISPLAY DEVICE, DISPLAY RESULTS, and DISPLAY VARY commands, assume that 65,528 bytes (64KB) suffice.

For REMOVE DEV, RESTORE DEV, and the QUERY commands, calculate $100 + (1 + x) * y * z$, where:

- x One of the following:
 - The number of objects in a QUERY ENTITY, REMOVE DEV, or RESTORE DEV command
 - The number of interfaces in a QUERY INTERFACE command
 - The number of paths in a QUERY RELATION command (in this context, number is the number from one host's perspective).
- y Number of hosts scoped in the command
- z Size of the output row (the following sizes are approximations):
 - z 250 for a REMOVE DEV or RESTORE DEV command
 - z 300 for a QUERY ENTITY or QUERY INTERFACE command
 - z 500 for a QUERY RELATION command

For all other commands, assume that 25,600 bytes (24KB) suffice.

For invocations by a REXX EXEC, the final size should be doubled because I/O operations uses the IRXEXCOM facility to access ihvrc, ihvreas, and ihvresp, and it uses the STORE function of IRXEXCOM to set them.

Safe Switching

I/O operations varies paths online or offline when, because of port manipulation, the path from a channel to a device either becomes valid or is no longer valid.

The term *safe-switching* means that *all* vary path offline requests due to an I/O operations connectivity command are backed out if *one* of these requests fails and BACKOUT was specified at command invocation. All requests means those requests on all systems that have access to the switch (or switches) that are affected by the command.

For FICON® switches, safe-switching also includes the entire vary process for connectivity commands that affect Inter-Switch-Link ports (E-ports). Because I/O operations does not know the topology between the entry switch and the destination switch of a path, paths that go through an ISL link will not be varied when an E-port is the target of a connectivity command.

The following conditions result in the failure of a request:

- A vary path offline request fails when the request would disable the last path to a device that is currently in use.
- If no VTAM connection could be established between two systems that have access to a switch and run I/O operations, I/O operations on the local system (that is, where the command is entered) assumes that the command fails on the remote system.

To avoid this, exclude this system from consensus processing using the command RESET HOST *vtamname* PURGE.

- For other reasons refer to the section "Making Connectivity Changes" in Appendix A, "Definitions for I/O Operations Commands" in *IBM Tivoli System Automation for z/OS Operator's Commands*.

FICON Switches

FICON switches allow imbedded space characters on port names. Consequently, I/O operations will not issue message IHVD106I when detecting imbedded blanks in port names of FICON switches.

However, I/O operations does not support imbedded blanks on port names, either in the ISPF dialogs or in the console command interface. The reason is that generic names and port names must not contain imbedded blanks when used in I/O operations console commands.

FICON Cascaded Switches

I/O operations supports cascaded switches with some restrictions:

1. For CTC connections on cascaded switches, I/O operations can neither display CTC control unit data nor manage CTC devices. The reason for this is that when I/O operations attempts to determine the attached NDs of such a device, it can get stuck behind a never-ending channel program on the device.
2. The Block command is not supported on Inter-Switch-Link ports (E_Ports). When an E_Port is affected by the command, it is rejected with return code 8

Using I/O Operations Commands for Programming

and reason code X'49'. In addition, the message IHVC913I is issued, showing the first or only port that is affected by the command.

3. All other I/O operations commands affecting E_Ports (Allow, Prohibit, Unblock, WRITEPORT and WRITESWCH) must specify the command option IGNore when an E_Port is involved. Otherwise the command is rejected with return code 8 and reason code X'49'. In addition, the message IHVC913I is issued, showing the first or only port that is affected by the command.
The IGNore option makes the issuer of the command aware that *safe-switching* can no longer be guaranteed.
4. If an attached Node Descriptor of a device cannot be determined because the path or channel is offline, the Display Device command does not show any control unit data for the particular channel path id.
5. A dynamic configuration change that results in the allocation or deallocation of a cascaded switch is currently *not* supported.

Note: It is recommended that all switches are defined to the Hardware Configuration Definition (HCD) including their device numbers. This allows I/O operations to also show the LSN for cascaded switches.

Common Elements

Many of the commands described in this chapter share several elements (such as syntax, parameters, output headers, etc.) that are described in this section. To help make the command descriptions that follow a little clearer, the descriptions of these common parameters will not be repeated. Instead, you will be referred to the relevant part of this section.

The common elements are:

- Various syntax elements, see “Common Syntax Elements”
- Various parameters, see “Common Parameters” on page 177
- The syntax for Query Entity/Interface/Relation commands, see “Common Query Commands Syntax” on page 181
- Output header for all Query Entity/Interface output structures, see “Common Output Header” on page 183
- Output for all Query Relation commands, see “Common Output Format” on page 184

Common Syntax Elements

The following syntax elements are common to several commands:

- Object Format
- Single_object_identifier
- Range_object_identifier
- Scope
- Host_object_identifier

In the syntax diagrams for the commands in this chapter these syntax elements are shown only as syntax fragments.

Object Format:

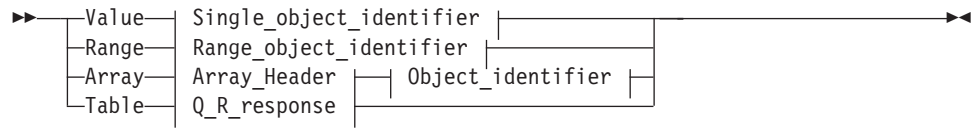

Single_object_identifier:

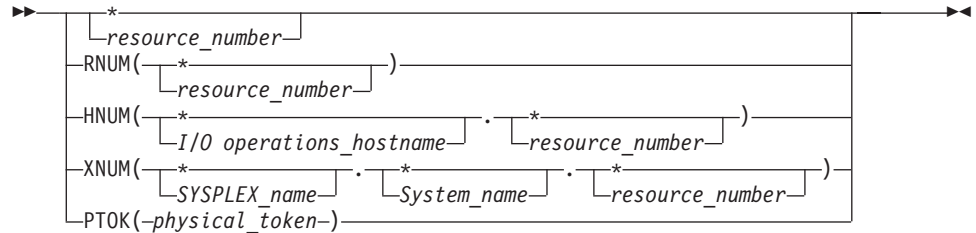

Range_object_identifier:

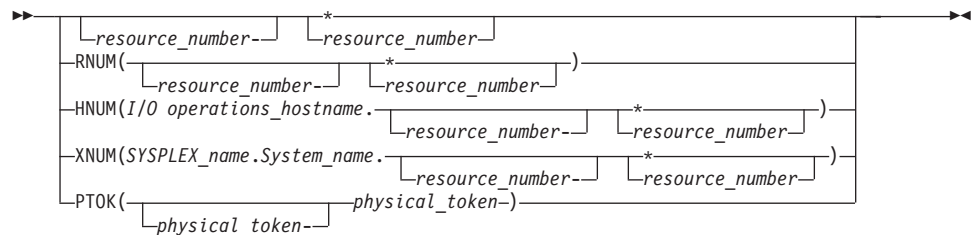

Scope:

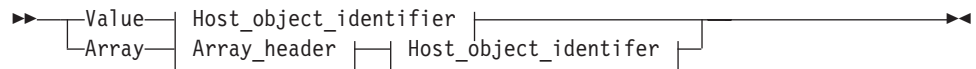

Host_object_identifier:

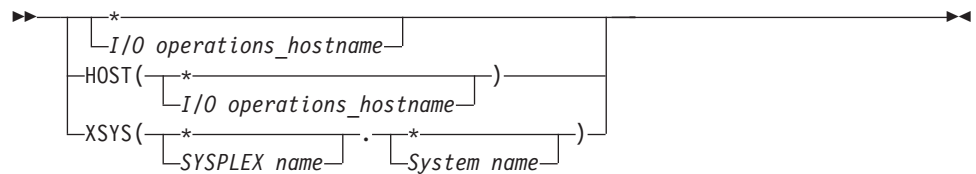

Common Parameters

These common parameters are:

- Object Identifier (see “Object Identifiers” on page 178):
 - Value
 - Range
 - Array
 - Table
- I/O resource identifiers (see “I/O Resource Identifiers” on page 178):
 - RNUM
 - HNUM
 - XNUM

Common Elements

- PTOK
- LTOK
- Host identifiers (see “Host Identifiers” on page 180):
 - HOST
 - XSYS
 - SCOPE

Object Identifiers

Value *value* | *

Specify V or VALUE. Then, specify either a single *element* or * for all *elements* known to the issuing I/O operations. (If * is specified, output array elements are sorted by searched element.)

Note: An element can either be a CHIPID, CONTROL UNIT or a DEVICE NUMBER.

Range *lower-upper* | *lower*-*

Specify R or RANGE. Specify the lower limit, followed by a hyphen, followed either by the upper limit of the range or an asterisk '*' to specify the highest number. Output array elements are sorted by number.

Array

Specify A or ARRAY. The output of array elements is returned in the input order. Specify the input array in the following format:

Table 8. Standard SA z/OS Array Format

Offset					
Dec	Hex	Type	Len	Name(Dim)	Description
0	(0)	UNSIGNED	4	NUM_ROWS	Number of elements
		1... ..		FMT	Array format
				1	SA z/OS formatted array
4	(4)	UNSIGNED	1	FMT_ID	Format identifier. Only 0 is valid for SA z/OS arrays
5	(5)	CHARACTER	3	*	Reserved
Array elements					
8	(8)	CHARACTER	38	OBJ_ID(*)	Object identifier

Notes:

1. Up to 32767 (decimal) CHPIDs can be entered for CHP, but for CNTLUNIT and DEV the overall size is restricted to 32000 control unit numbers or device numbers respectively.
2. SA z/OS continues to support the ESCON® Manager Release 2 format for input arrays. For information about this format, see *Using the Enterprise Systems Connection Manager*.

Table

Specify T or TABLE. Requires CODE=1 and the RESPONDER host application name must match the scope host name to be operated on. The table format is identical to the output format of a QUERY RELATION command.

I/O Resource Identifiers: An I/O resource identifier type can be one of the following:

RNUM

RNUM is an identifier value that is a resource number. All I/O resource object types have a resource number. Each object type specifies it differently, such as:

CHP

Channel path identifier

CU

Control unit number

DEV

Device number

SWITCH

Switch device number

The value for RNUM must be from 1 to 4 hexadecimal characters or an asterisk (*).

Examples:

```
*
40
40-*
40-4F
RNUM(*)
RNUM(100)
RNUM(100-*)
RNUM(100-10F)
```

HNUM

HNUM is an identifier value that is qualified by an I/O operations host name. It is a specific host's resource number. HNUM must be 1 to 8 alphanumeric characters for the host name (or be an asterisk), followed by a period (.), followed by 1 or 2 hexadecimal characters for the resource number (or be an asterisk).

Examples:

```
HNUM(*.*)
HNUM(*.40)
HNUM(H1.*)
HNUM(H1.40)
HNUM(H1.40-*)
HNUM(H1.40-4F)
```

XNUM

XNUM is an identifier value that is qualified by a sysplex name and a system name. It is a specific sysplex system's resource number. XNUM must be 1 to 8 alphanumeric characters for the sysplex name (or be an asterisk), followed by a period (.), followed by 1 to 8 alphanumeric characters for the system name (or be an asterisk), followed by a period (.), followed by 1 or 2 hexadecimal characters for the resource number (or be an asterisk).

Examples:

```
XNUM(*.*.*)
XNUM(*.S1.40)
XNUM(X1.*.40)
XNUM(X1.S1.*)
XNUM(X1.S1.40)
XNUM(X1.S1.40-*)
XNUM(X1.S1.40-4F)
```

PTOK

PTOK is an identifier value that is a physical token. PTOK is a 32-character field. Refer to *IBM Tivoli System Automation for z/OS Operator's Commands* for further information about physical tokens.

Examples:

Common Elements

```
PTOK(... 009032002IBM020000000000100)
PTOK(... 009032002IBM020000000000100-...009032002IBM0200000999999900)
```

L TOK

L TOK is an identifier value that is a logical token. L TOK is a 32-character field. Refer to *IBM Tivoli System Automation for z/OS Operator's Commands* for further information about logical tokens.

Examples:

```
L TOK(0123456789ABCDEF0123456789ABCDEF)
L TOK(0123456789ABCDEF0123456789ABCDEF-0123456789ABCDEF0123456789ABCDEF)
```

Host Identifiers: A host identifier type can be one of the following:

HOST

HOST is an identifier value that is an I/O operations' VTAM application name or an I/O operations' TCP/IP host name. HOST must be from 1 to 8 alphanumeric characters for the host name (or be an asterisk).

Examples:

```
HOST(*)
HOST(H1)
HOST(H1-*)
HOST(H1-H9)
```

XSYS

XSYS is an identifier value that is a sysplex name, or a system name, or both. The rules are:

- If both a sysplex name and system name are specified, only that system in the sysplex is considered for the command
- If a specific sysplex name is specified, only the systems in that sysplex are considered for the command
- If a specific system name is specified, only the systems with that name are considered for the command

XSYS must be from 1 to 8 alphanumeric characters for the sysplex name (or be an asterisk), followed by a period (.), followed by 1 to 8 alphanumeric characters for the system name (or be an asterisk).

Examples:

```
XSYS(*.*)
XSYS(*.S1)
XSYS(X1.*)
XSYS(X1.S1)
XSYS(*.S1-*)
XSYS(*.S1-S9)
XSYS(X1.S1-*)
XSYS(X1.S1-S9)
```

SCOPE

SCOPE specifies the set of I/O operations hosts that respond to a multisystem command.

NOPATHTEST

No checking is done on the command to verify that the path from the CHPID to the device exists.

Note: For QUERY RELATION HOST, the NOPATHTEST option is only valid on the QUERY RELATION HOST to Device command.

PATHTEST

If you specify Pathtest on the command, checking is done to verify that the device is physically there with relation to each CHPID.

Note: For QUERY RELATION HOST, the PATHTEST option is only valid on the QUERY RELATION HOST to Device command.

Notes:

1. When ARRAY is the *Object_format_type*, the *Object_Identifier_Types* can be mixed and every *Object_Identifier_Type* must match the class of the specified *Object_Type* (all must be I/O_resources or all must be Hosts). For example, Q E HOST can accept only HOST and XSYS entries in the array.
2. The Array_header contains the number of elements in the array.
3. PTOK is valid with RANGE but you should be fully aware of PTOK structure. For example, RANGE PTOK could be used to specify all of the serial numbers of a certain type of device. However, certain PTOK values may cause unpredictable results with RANGE.
4. When ARRAY is the *SCOPE_format_type*, the *Host_Object_Identifier_Types* can be mixed (HOST and XSYS).
5. Output from a QUERY ENTITY command consists of a header, which is identical for each entity with the exception of the "Eye-Catcher" (offset 0), followed by the substructures, which are unique to each type of entity.
6. If not otherwise stated at the particular command descriptions no input port information is returned by a QUERY RELATION command when the command specifies a switch that is the destination switch of a cascaded switch pair.

Common Query Commands Syntax

The following syntax is common for all Query Entity/Interface/Relation commands.

(Host_)Entity_Object:

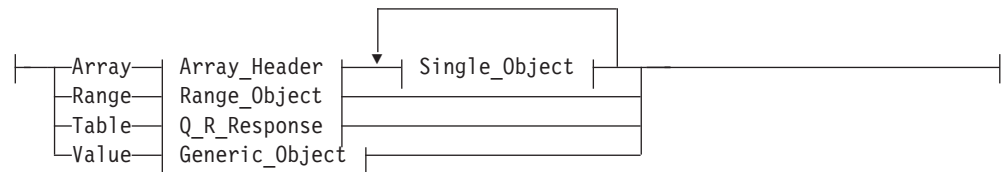

Interface_Object:

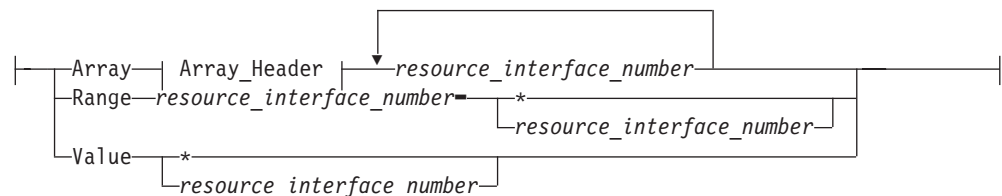

(Host_)Relation_Object:

Common Elements

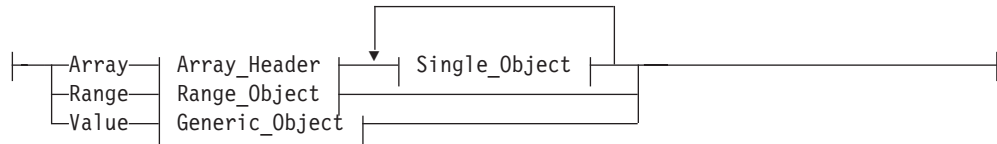

Single_Object (when object type is I/O resource):

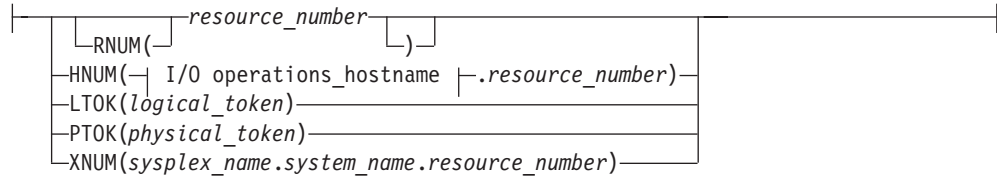

Single_Object (when object type is HOST):

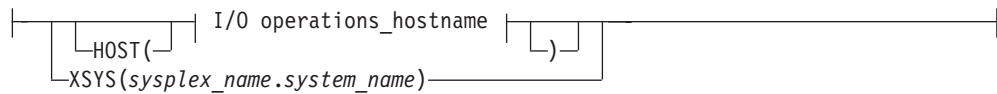

Generic_Object (when object type is I/O resource):

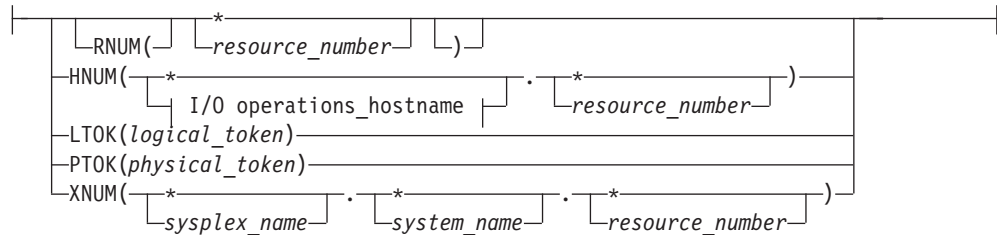

Generic_Object (when object type is HOST):

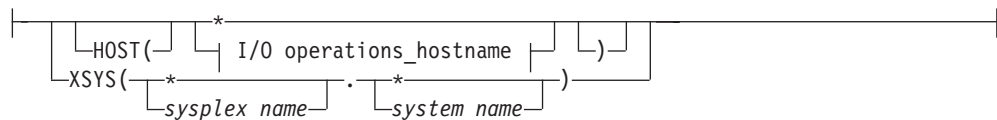

Range_Object (when object type is I/O resource):

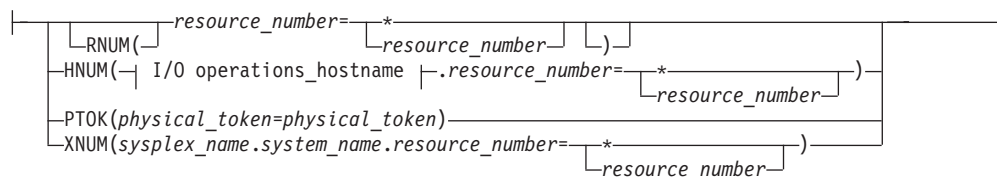

Range_Object (when object type is HOST):

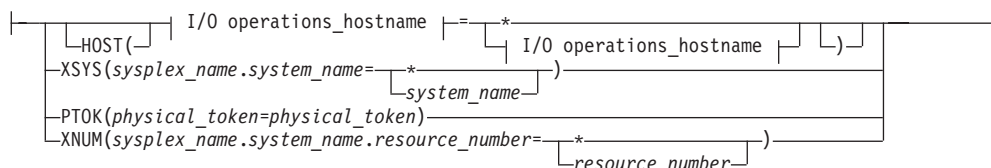

I/O operations_hostname:

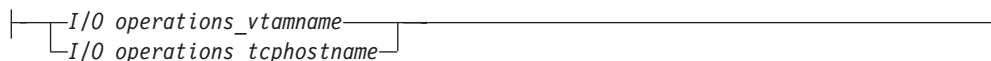

Scope:

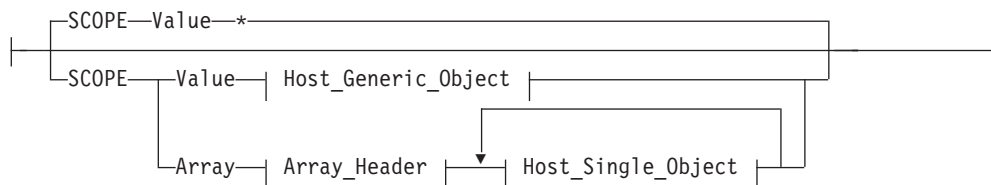

Options:



Common Output Header

Table 9 shows the common output header that is produced for all QUERY ENTITY/INTERFACE output structures.

Table 9. Header for all Query Entity/Interface Output Formats

Offset					
Dec	Hex	Type	Len	Name(Dim)	Description
0	(0)	STRUCTURE	80	HDR	
0	(0)	CHARACTER	4	EYE_CATCHER	Identifies the control block QEC Query Entity Chp QED Query Entity Device QEH Query Entity Host QES Query Entity Switch QEU Query Entity Cntlunit QIS Query Interface Switch QIU Query Interface Cntlunit
4	(4)	UNSIGNED	2	HDR_SIZE	Size of this header
6	(6)	UNSIGNED	2	ROW_SIZE	Size of array element
8	(8)	CHARACTER	8	ESCM_HOST	Responding host VTAM application name or TCP/IP host name
16	(10)	CHARACTER	4	ESCM_REL	SA z/OS version and release
20	(14)	CHARACTER	32	HOST_PID	Host physical identifier
20	(14)	BITSTRING	1	*	
		111.		VALIDITY	0 = Valid 1 = Not current 2 = Not valid
		...1 1111		*	Reserved
21	(15)	CHARACTER	3	*	Reserved

Common Elements

Table 9. Header for all Query Entity/Interface Output Formats (continued)

Offset					
Dec	Hex	Type	Len	Name(Dim)	Description
24	(18)	CHARACTER	6	TYPE_NUM	Processor type, e.g. 002064
30	(1E)	CHARACTER	3	MODEL_NUM	Processor model, e.g. 108
33	(21)	CHARACTER	3	MFR	Manufacturer, e.g. IBM
36	(24)	CHARACTER	2	PLANT	Where manufactured
38	(26)	CHARACTER	12	SEQUENCE_NUM	Serial number
50	(32)	BITSTRING	2	STATUS	Status of PID
		1... ..		AMBIGUOUS	Ambiguous state detected on PID
		.1... ..		REFLECTED	PID is derived from attached ND
		..11 1111 >>		*	Reserved
52	(34)	UNSIGNED	4	NUM_ROWS	Dimension of array following this header
56	(38)	UNSIGNED	1	FORMAT_ID	Identifies format of data
57	(39)	BITSTRING	1	*	
		1... ..		MORE_DATA	0 = All data that satisfies query is returned here. 1 = More data satisfies query (but won't fit now). Ask again with RANGE parameter type.
		.1... ..		TCP_HOST	1 = ESCM_HOST contains the TCP/IP host name
		.111 1111		*	Reserved
58	(3A)	CHARACTER	8	PLEX_NAME	Sysplex name (blank if none)
66	(42)	CHARACTER	8	SYST_NAME	System name
74	(4A)	CHARACTER	2	*	Reserved
76	(4C)	UNSIGNED	4	NUM_HOSTS	Number of hosts responding

Common Output Format

Table 10 shows the output that is common to all Query Relation commands.

Table 10. Output Format of all Query Relation Commands

Offset					
Dec	Hex	Type	Len	Name(Dim)	Description
0	(0)	STRUCTURE	*	QRO	
0	(0)	CHARACTER	48	HDR	Header data
0	(0)	CHARACTER	4	EYE_CATCHER	Identifies control block ('QRO')
4	(4)	UNSIGNED	2	HDR_SIZE	Length of (this) QRO.HDR
6	(6)	UNSIGNED	2	ROW_SIZE	Length of 1 ROW
8	(8)	CHARACTER	8	ESCM_HOST	Responding host VTAM application name or TCP/IP host name
16	(10)	CHARACTER	4	ESCM_REL	SA z/OS version and release
20	(14)	UNSIGNED	4	NUM_ROWS	ROW dimension
24	(18)	UNSIGNED	1	FORMAT_ID	Identifies format of table
25	(19)	BITSTRING	1	*	
		1... ..		MORE_DATA	0 = Entire Query response in QRO 1 = Query response too large to fit in QRO (ask again, use RANGE)
		.1... ..		PATHTEST	1 = PATHTEST requested
		.1... ..		TCP_HOST	1 = ESCM_HOST contains the TCP/IP host name
		..11 1111		*	Reserved

Table 10. Output Format of all Query Relation Commands (continued)

Offset					
Dec	Hex	Type	Len	Name(Dim)	Description
26	(1A)	CHARACTER	8	PLEX_NAME	Sysplex name (blank if none)
34	(22)	CHARACTER	8	SYST_NAME	System name
42	(2A)	CHARACTER	2	*	Reserved
44	(2C)	UNSIGNED	4	NUM_HOSTS	Number of hosts responding
Path descriptions					
48	(30)	CHARACTER	372	ROW(*)	Indexed by HDR.NUM_ROWS
48	(30)	CHARACTER	8	HOST_APPL	Host VTAM application name
56	(38)	UNSIGNED	1	CHPID	Channel path identifier (00-FFx)
57	(39)	UNSIGNED	1	PORTIN	When data is flowing from the host, the input port on the switch (if a switch is in the path)
58	(3A)	UNSIGNED	2	SW_DEVN	Switch device number (if a switch is in the path).
60	(3C)	UNSIGNED	1	LSN	Logical switch number (that goes with SW_DEVN) when a switch is in the path.
61	(3D)	UNSIGNED	1	PORTOUT	When data is flowing from the host, the output port on the switch (if a switch is in the path)
62	(3E)	UNSIGNED	2	CU_NUMBER	Control unit number
64	(40)	UNSIGNED	2	DEV_NUMBER	Device number
The following bits describe the validity of the data in the corresponding row					
66	(42)	BITSTRING	2	STATBITS	Indicate row data validity
		1... ..		VALID_DATA	1 = This row contains a valid path 0 = This row does not contain a valid path—either the entity2 is not found in the database at all or there is no relation between the entity1 and entity2 specified
		.1... ..		INCOMPLETE	0 = Queried data is in database (i.e. not a proxy request) 1 = Queried data not known (i.e. secondary host databases are not known)
The following bits describe switch data validity					
		..1.		VALID_SW	1 = SW_DEVN is valid (switch either is or was operational)
		...1		VALID_LSN	1 = LSN is valid (path is switched)
	 1...		VALID_PORTIN	1 = PORTIN value is verified
	1..		VALID_PORTOUT	1 = PORTOUT value is verified
The following bits indicate which path elements are detected to be involved in an ambiguous state.					
	1.		AMBIG_PORTIN	1 = CHCH, CHCU detected on PORTIN
	1		AMBIG_PORTOUT	1 = CHCU detected on PORTOUT
The following bits indicate whether ports (paths) are involved with chained or cascaded switches.					
67	(43)	1... ..		CHAIN_PORTIN	1 = PORTIN is part of CHAIN
		.1... ..		CHAIN_PORTOUT	1 = PORTOUT is part of CHAIN
		..1.		VALID_DEVNUM	1 = DEV_NUMBER contains data and the DEV_NUMBER is defined in the configuration

Common Elements

Table 10. Output Format of all Query Relation Commands (continued)

Offset							
Dec	Hex	Type	Len	Name(Dim)	Description		
		...1		PATHTEST	1 = PATHTEST data is available		
	 1...		VALID_CUNUM	1 = CU_NUMBER contains data and the CU_NUMBER is defined in the configuration		
	1..		CU_ISA_CF	1 = CU in this row is a coupling facility so PTOK mapping is for ND (when 0, PTOK mapping is for NED)		
	1.		VALID_CHP	1 = CHPID contains a value that is defined in the configuration		
	1		CASCADED_SW	1 = If PORTOUT is valid it represents the output port on the destination switch		
The following indicates whether the current row is to be processed when this table is used as input (to a Query Entity command).							
68	(44)	UNSIGNED	1	CODE	For Query Entity command. This space is used to tell IHV whether to operate on the given row.		
					0 = Ignore this row		
					1 = Operate on is row		
					2-255 = Reserved (row ignored if specified)		
69	(45)	CHARACTER	1	*	Workarea for internals		
The following bits describe data validity of the destination (cascaded) switch							
70	(46)	BITSTRING	1	STATBITS2	Indicate data validity		
		1...		VALID_DEST_LSN	1 = LSN of destination switch is valid		
		.1...		VALID_DEST_SW	1 = Device number of destination switch is valid		
		..11 1111		*	Reserved		
71	(47)	BITSTRING	1	*			
		1...		TCPNAMER	1 = APPLNAMER contains the TCP/IP host name		
		.111 1111		*	Reserved		
72	(48)	CHARACTER	8	SYSPLEX	Sysplex name (blank if none)		
80	(50)	CHARACTER	8	SYSTEM	System name		
88	(58)	CHARACTER	24	RESPONDER	Responder ID		
88	(58)	CHARACTER	8	APPLNAMER	Responder host VTAM application ID or TCP/IP host name		
96	(60)	CHARACTER	8	SYSPLXR	Responder host sysplex name		
104	(68)	CHARACTER	8	SYSTEMR	Responder host system name		
112	(70)	UNSIGNED	4	RCODE	Return/reason code for row		
A PATH_AVAIL is returned ONLY when chp/switdevn, chp/cunum or chp/devnum are in the row. In other words, the following commands will return PATH_AVAIL data (when the row contains valid and complete data): Query Relation Host or Chp to Switch (where SWDEVN is set) Query Relation Host or Chp to CntlUnit or Dev and Query Relation Dev or CU or Switch to Host or Chp							
116	(74)	BITSTRING	4	PATH_AVAIL	Last known state of this path from CHSC "Store Sch Path Info" instruction		
116	(74)	BITSTRING	1	CHSC_LEVEL	Level (i.e. scope) of info:		

Table 10. Output Format of all Query Relation Commands (continued)

Offset				
Dec	Hex	Type	Len	Name(Dim) Description
		'10'x =		Error affects entire chp
		'20'x =		Error affects destination link
		'30'x =		Error affects logical path
		'40'x =		Error affects I/O on logical path
117	(75)	BITSTRING	2	CHSC_CODE Status code and modifier:
117	(75)	BITSTRING	1	STATCODE Status code
118	(76)	BITSTRING	1	MODCODE Modifier code
		'0000'x =		No data available (ESCM value)
		'00FF'x =		Available, operational last time used
		'1010'x =		Chpid type does not match hardware type
		'1020'x =		Serial CTC feature not installed
		'1030'x =		ESCON chp connected to ESCON chp (defn err)
		'1040'x =		SCTC connected to ESCON CU
		'1050'x =		Non-CVC connected to converter
		'1060'x =		CVC channel without converter
		'1070'x =		CNC/multiple CU connection with no ESCD
		'1080'x =		No CU link address defined
		'1090'x =		Duplicate link address with port and CU
		'10A0'x =		Msg facility channel connected to another msg facility channel
		'10C0'x =		Buffer sizes incompatible between msg facility channel and msg-processor intersystem channel
		'10xx'x =		Path in definition error, no further info
		'2010'x =		Chpid not configured online
		'2020'x =		Chpid is in check stop state
		'2030'x =		Chpid is in permanent error
		'20xx'x =		Chpid is unavailable
		'30FF'x =		Wrap block is installed
		'40FF'x =		Chpid is in terminal state
		'5010'x =		Loss of signal or sync
		'5020'x =		Not-op sequence recognized
		'5030'x =		Sequence timeout
		'5040'x =		Illegal sequence received
		'50xx'x =		Link failure detected
		'60FF'x =		In offline reception state
		'7010'x =		Port reject—address invalid
		'7011'x =		Undefined destination error
		'7012'x =		Destination port malfunction
		'7013'x =		Port intervention required
		'70xx'x =		Port reject (when no other applies)
		'8001'x =		Link reject—transmit error
		'8005'x =		Link reject—dest. address invalid or error
		'8007'x =		Reserved field error
		'8008'x =		Unrecognized link control function
		'8009'x =		Protocol error
		'800A'x =		ALA error
		'800B'x =		Unrecognized device level
		'80xx'x =		Link level reject encountered
		'9010'x =		Connection error
		'9020'x =		Channel detected transmission error
		'9030'x =		Protocol error
		'9040'x =		Destination address invalid
		'9050'x =		Device level error
		'90xx'x =		Channel link level error

Common Elements

Table 10. Output Format of all Query Relation Commands (continued)

Offset					
Dec	Hex	Type	Len	Name(Dim)	Description
		'A001'x =			Pacing parameters error
		'A002'x =			Logical path resource unavailable
		'A004'x =			CU image does not exist
		'A005'x =			Logical path precluded at CU
		'A0xx'x =			Logical path unavailable
		'B010'x =			CU-device initialization in progress
		'B020'x =			Link busy last encountered
		'B030'x =			Port busy last encountered
		'B040'x =			Chpid busy last encountered
		'B0xx'x =			Path initialization in progress
		'C010'x =			Select-in or address exception
		'C0xx'x =			SCH path ok but device not operational
		'FFFF'x =			Unknown state or no further info available
SCPSTATE is returned ONLY when a complete path from chpid to device (or switch device) is in the row.					
120	(78)	BITSTRING	1	SCPSTATE	State of path from SCP
		1...		ONLINE	1 = Path is online to SCP
		.1..		OFFLINE	1 = Path is offline to SCP
		..11 1111		*	Reserved
Destination switch information					
121	(79)	UNSIGNED	1	DEST_SWCH_LSN	LSN of destination switch
122	(7A)	UNSIGNED	2	DEST_SWCH_DEVN	Device number of destination switch
A LPE_STATUS.ESCON is returned whenever there is a chpid in the row. LPE_STATUS.LPE is ONLY returned when the row contains a valid chpid along with valid switch devnum, cunum or device number.					
124	(7C)	BITSTRING	1	LPE_STATUS	Logical path established indicators
		1...		LPE_VALID	1 = This path supports LPEs AND LPE info is valid
		.1..		LPE	0 = No path established. 1 = A logical path is established (CHSC info). LPE_VALIDbit validates this field.
		..11 1111		*	Reserved
A PTMSG is returned ONLY when PATHTEST is specified in the command. If PATHTEST is not specified, binary zeros are returned in this field.					
125	(7D)	CHARACTER	71	PTMSG	MVS or ESCM message due to issuing I/O down this path. Valid only when PATHTEST specfd.
TOKS are returned for every command where the associated (RNUM) item is set. Additionally, CU & DEV physical tokens are refreshed for each row when PATHTEST is specified.					
Note: Logical tokens consisting of 32 bytes of binary zeros denotes that the LTOK is not valid/available.					
196	(C4)	CHARACTER	224	TOKS	Logical/Physical tokens
Chpid tokens:					
196	(C4)	CHARACTER	32	CHP_PTOK	Actually determined ND Chpids do not have logical tokens
Switch tokens:					
For Query Relation Switch-Switch commands, the tokens returned here are for the entity2 (chained) switch.					
228	(E4)	CHARACTER	32	SWIT_PTOK	Switch NED if switch is OPEN, or PID if switch is not open (or defined?).

Table 10. Output Format of all Query Relation Commands (continued)

Offset					
Dec	Hex	Type	Len	Name(Dim)	Description
260	(104)	CHARACTER	32	SWIT_LTOK	Only valid if this switch is defined as a device to this host—then inherited from CU for this switch.
Control Unit tokens:					
292	(124)	CHARACTER	32	CU_PTOK	NED (or ND if CU_ISA_CF)
324	(144)	CHARACTER	32	CU_LTOK	From HCD
Device tokens:					
356	(164)	CHARACTER	32	DEV_PTOK	NED
388	(184)	CHARACTER	32	DEV_LTOK	From HCD
420	(1A4)	CHARACTER	0	*	Reserved (to round)

DELETE FILE

Purpose

Use the DELETE FILE command at the I/O operations API to delete a saved switch configuration that is stored at the switch specified in the command. The switch must be allocated to the issuing I/O operations.

Syntax

►►—DELEte File—*filename*—*swchdevn*—◄◄

Parameters

filename

Specify the file name in 1 through 8 valid EBCDIC codes. Valid codes are uppercase alphabetical characters (A-Z), digital characters (0-9), and 2 special character: the underscore (_) and the hyphen (-). However, do not specify the following file names: AUX, COM n (where $n=1-4$), CON, IPL, LPT n (where $n=1-3$), NUL, or PRN.

swchdevn

Specify the switch device number in up to 4 hexadecimal digits. The switch must be allocated, or attached, to the issuing I/O operations. You can issue the DISPLAY SWITCH command to obtain a list of these switches.

Usage

You cannot delete the switch IPL file, which is supplied with each IBM Director and is activated automatically when the unit is powered on.

QUERY ENTITY CHP

Purpose

Use the QUERY ENTITY CHP command at the API to obtain data about the channel path (Chp) that you specify.

QUERY ENTITY CHP

Query Parameters

►►—Query Entity Chp—| Entity_Object |—| Scope |—————►►

Output

The format of the output from QUERY ENTITY CHP is as follows:

Table 11. QUERY ENTITY CHP Output

Offset					
Dec	Hex	Type	Len	Name(Dim)	Description
0	(0)	STRUCTURE	*	QEC	
The header for all Query Entity/Interface output structures is not listed here. Its size is 80 bytes. For details see "Common Output Header" on page 183.					
80	(50)	CHARACTER	184	CHPS(*)	Individual chp data
80	(50)	UNSIGNED	1	CHPID	Channel path ID
81	(51)	BITSTRING	1	STATBITS	
		1... ..		VALID_DATA	1 = This chpid is defined on host
		.111 111.		*	Reserved
	1		TCPNAMER	1 = APPLNAMER contains the TCP/IP host name
82	(52)	CHARACTER	32	CHP_PTOK	Physical Token
82	(52)	CHARACTER	32	ND_DET	Determined ND: "who am I"
114	(72)	CHARACTER	32	ND_ATT	Attached ND: "who are you"
146	(92)	UNSIGNED	1	TYPE	
		'00'x = UNDEF		Unknown	
		'01'x = BLOCK		Parallel block multiplex	
		'02'x = BYTE		Parallel byte multiplex	
		'03'x = CNC_P		ESCON point to point	
		'04'x = CNC_?		ESCON switched or point to point	
		'05'x = CNC_S		ESCON switched point to point	
		'06'x = CVC		ESCON path to a block converter	
		'07'x = NTV		Native interface	
		'08'x = CTC_P		CTC point to point	
		'09'x = CTC_S		CTC switched point to point	
		'0A'x = CTC_?		CTC switched or point to point	
		'0B'x = CFS		Coupling facility sender	
		'0C'x = CFR		Coupling facility receiver	
		'0F'x = CBY		ESCON path to a byte converter	
		'10'x = OSE		OSA express	
		'11'x = OSD		OSA direct express	
		'12'x = OSA		Open systems adapter	

Table 11. QUERY ENTITY CHP Output (continued)

Offset					
Dec	Hex	Type	Len	Name(Dim)	Description
		'13'x = ISD			
		Internal system device			
		'16'x = CBS			
		Cluster bus sender			
		'17'x = CBR			
		Cluster bus receiver			
		'18'x = ICS			
		Internal coupling sender			
		'19'x = ICR			
		Internal coupling receiver			
		'1A'x = FC			
		FICON point to point			
		'1B'x = FC_S			
		FICON switched			
		'1C'x = FCV			
		FICON to escon bridge			
		'1D'x = FC_?			
		FICON incomplete			
		'1E'x = DSD			
		Direct system device			
		'1F'x = EIO			
		Emulated I/O			
		'21'x = CBP			
		Integrated cluster bus peer			
		'22'x = CFP			
		Coupling facility peer			
		'23'x = ICP			
		Internal coupling peer			
		'24'x = IQD			
		Internal queued direct comm			
		'25'x = FCP			
		FCP channel			
		Other values are reserved			
147	(93)	CHARACTER	1	TRAITS	Chp characteristics
		1... ..		ONLINE	1 = Chpid is operational on this host
		.1.. ..		DCM_MANAGED	1 = Chpid is DCM managed on this host
		..11 ..		*	Reserved
	 1111		PROTOCOL	Interface protocol used: 0 = Unspecified 1 = LED 2 = Laser 3 = Laser-1 (shortwave) 4 = Laser-2 (shortwave) 5 = Laser-3 (longwave) Other values are reserved
Entity Attribute Mask					
148	(94)	BITSTRING	4	EAM	

QUERY ENTITY CHP

Table 11. QUERY ENTITY CHP Output (continued)

Offset							
Dec	Hex	Type		Len	Name(Dim)	Description	
		1111		LOG_CLASS	Logical entity classification: 0 = Unspecified 1 = Host 2 = Chpid 3 = Switch 4 = Control unit 5 = Device 7 = Ambiguous (CHCU, etc) other values are reserved	
		1111		PHYS_CLASS	Physical entity classification: 0 = Unspecified 1 = Host 2 = Chpid 3 = Switch 4 = Control unit 5 = Device 6 = ESCON mod2 converter 7 = Ambiguous (link is static (no ND_ATT) and IODEF is ambiguous) 8 = CF internal path (only set for CUs) other values are reserved	
149	(95)	BITSTRING		2	STATE	State of the entity	
		1...		LOGICAL	1 = Entity is logical	
		.1..		P_CURR	1 = Entity is physically current	
		..1.		P_HIST	1 = Entity is physical history	
		...1		LOG_OTHER	1 = Logical by another interface	
		1...		P_OTHER_CURR	1 = Physical by another interface	
	1..		P_OTHER_HIST	1 = Physical history by other interface	
	1.		P_INDIRECT	1 = The EAM validity was derived from the attached (ND) interfaces from the control unit 0 = The EAM validity was obtained from the CU itself (can only be true for opened switches)	
	1		P_AMB	1 = Physical ambiguous configured on some interface	
150	(96)	1...		LOG_AMB	1 = Logical ambiguous configured on some interface	
		.1..		CLASS_AMB	1 = Logical and physical classes are not compatible	
		..11	1111 >>		*	Reserved	
End of Entity Attribute Mask							
Attached Entity Attribute Mask							
152	(98)	BITSTRING		4	AEAM		

Table 11. QUERY ENTITY CHP Output (continued)

Offset							
Dec	Hex	Type	Len	Name(Dim)	Description		
		1111		LOG_CLASS	Logical entity classification:		
					0 = Unspecified		
					1 = Host		
					2 = Chpid		
					3 = Switch		
					4 = Control unit		
					5 = Device		
					7 = Ambiguous (CHCU, etc)		
					other values are reserved		
	 1111		PHYS_CLASS	Physical entity classification:		
					0 = Unspecified		
					1 = Host		
					2 = Chpid		
					3 = Switch		
					4 = Control unit		
					5 = Device		
					6 = ESCON mod2 converter		
					7 = Ambiguous (link is static (no ND_ATT) and IODEF is ambiguous)		
					8 = CF internal path (only set for CUs)		
					other values are reserved		
153	(99)	BITSTRING	2	STATE	State of the entity		
		1...		LOGICAL	1 = Entity is logical		
		.1..		P_CURR	1 = Entity is physically current		
		..1.		P_HIST	1 = Entity is physical history		
		...1		LOG_OTHER	1 = Logical by another interface		
	 1...		P_OTHER_CURR	1 = Physical by another interface		
	1..		P_OTHER_HIST	1 = Physical history by other interface		
	1.		P_INDIRECT	1 = The attached ND for the entity being queried is history but we got the chpid's validity from the chpid's det ND (which is always valid) so the AEAM is marked P_CURR for the (attached) chpid		
					0 = The attached ND and AEAM have the same validity		
	1		P_AMB	1 = Physical ambiguous configured on some interface		
154	(9A)	1...		LOG_AMB	1 = Logical ambiguous configured on some interface		
		.1..		CLASS_AMB	1 = Logical and physical classes are not compatible		
		..11 1111 >>		*	Reserved		
End of extrapolated entity descriptions							
156	(9C)	CHARACTER	36	OTHERS			

QUERY ENTITY CHP

Table 11. QUERY ENTITY CHP Output (continued)

Offset					
Dec	Hex	Type	Len	Name(Dim)	Description
156	(9C)	CHARACTER	32	ND	Extrapolation ND. This field is only valid when AEAM.P_OTHER or AEAM.P_OTHER_HIST are set (on). This ND can be expected to contain a value when either: <ul style="list-style-type: none"> The PID and ND validities differ (and the validity of this thing better be the same as the PID if there is a PID) There is more than 1 physical (only) path to an attached entity and the path that is being queried is not the most valid path. This ND should contain the identity of the more (most) valid (physical) path.
156	(9C)	BITSTRING	1	*	Indicates validity of this ND
		111.		NDVALID	
		...1 1111	*		Reserved
157	(9D)	CHARACTER	31	*	Rest of ND
188	(BC)	UNSIGNED	2	LOG	Extrapolated logical ID This is the lowest logically defined config number assigned to the entity. This field is only valid when AEAM.LOG_OTHER is set (on).
190	(BE)	CHARACTER	2	*	Reserved
192	(C0)	CHARACTER	24	RESPONDER	Responding host ID
192	(C0)	CHARACTER	8	APPLNAMER	VTAM application name or TCP/IP host name
200	(C8)	CHARACTER	8	SYSPLXR	Sysplex name
208	(D0)	CHARACTER	8	SYSTEMR	System name
216	(D8)	UNSIGNED	4	RCODE	Row return/reason code
220	(DC)	CHARACTER	5	CHPIDTYP	Channel type as string
225	(E1)	UNSIGNED	1	CSSID	Channel subsystem ID
226	(E2)	CHARACTER	38	CHPIDINFO	Resource Information
226	(E2)	CHARACTER	32	IODF_DESC	HCD User description
258	(102)	BITSTRING	1	*	Configure state of channel 0 = Reserved 1 = Online 2 = Offline/standby 6 = Offline/reserved Reserved (round to byte)
		111.		CONFIG_STATE	
		...1 1111	*		Reserved (round to even)
259	(103)	CHARACTER	1	*	Availability information
260	(104)	BITSTRING	4	ERROR_STATE	Last known state of this path from CHSC Store SCH Path Information (ERROR_STATE=0 -> no data avail)
260	(104)	BITSTRING	1	CHSC_LEVEL	Level (i.e. scope) of information
		'00'x =		No information available (I/O operations')	
		'10'x =		Error affects entire chp	
		'20'x =		Error affects destination link	
		'30'x =		Error affects logical path	
		'40'x =		Error affects I/O on the logical path	

Table 11. QUERY ENTITY CHP Output (continued)

Offset					
Dec	Hex	Type	Len	Name(Dim)	Description
261	(105)	BITSTRING	2	CHSC_CODE	Status code with modifier
261	(105)	BITSTRING	1	STATCODE	Status code
262	(106)	BITSTRING	1	MODCODE	Status modifier value
		'0000'x =			No data available (I/O operations value)
		'00FF'x =			Available, operational last time used
		'1010'x =			Chpid type does not match hardware type
		'1020'x =			Serial CTC feature not installed
		'1030'x =			ESCON chp connected to ESCON chp (definition err)
		'1040'x =			SCTC connected to ESCON CU
		'1050'x =			Non-CVC connected to converter
		'1060'x =			CVC channel without converter
		'1070'x =			CNC/multiple CU connection with no ESCD
		'1080'x =			No CU link address defined
		'1090'x =			Duplicate link address with port and CU
		'10xx'x =			Path in definition error, no further information

QUERY ENTITY CNTLUNIT

Purpose

Use the QUERY ENTITY CNTLUNIT command at the API to obtain data about the specified control unit (CU).

Query Parameters

→ Query Entity CntlUnit | Entity_Object | Scope | →

Output

The format of the output from QUERY ENTITY CNTLUNIT is as follows:

Table 12. QUERY ENTITY CNTLUNIT Output

Offset					
Dec	Hex	Type	Len	Name(Dim)	Description
0	(0)	STRUCTURE	*	QEU	
The header for all Query Entity/Interface output structures is not listed here. Its size is 80 bytes. For details see "Common Output Header" on page 183.					
80	(50)	CHARACTER	200	CUS(*)	Control unit descriptions
80	(50)	UNSIGNED	2	CU_NUMBER	Control unit number
82	(52)	CHARACTER	1	STATBITS	
		1... ..		VALID_DATA	1 = This control unit is defined in the IOCDS
		.1.. ..		CU_IS_SWITCH	1 = This control unit is a switch
		..1.		CU_IS_CF	1 = CU is a coupling facility
		...1 111.		*	Reserved
	1		TCPNAMER	1 = APPLNAMER contains the TCP/IP host name
83	(53)	UNSIGNED	1	CUADD	(IOCP) logical address
Physical (neighbor "who am I") Data					
84	(54)	CHARACTER	32	PID	CU's DERIVED physical identity (same format as in HDR)

QUERY ENTITY CNTLUNIT

Table 12. QUERY ENTITY CNTLUNIT Output (continued)

Offset					
Dec	Hex	Type	Len	Name(Dim)	Description
116	(74)	CHARACTER	32	CU_PTOK	Physical Token...remaps the NED (when the CU_IS_CF bit is off) or is an ND (when the CU_IS_CF bit is on (= '1'b)). See macro IXLMG for definition of the ND when the CU is a coupling facility.
116	(74)	CHARACTER	32	NED	Node Element Descriptor—CU's physical ID read from the control unit when this CU is not a coupling facility
		11..		NED_VALID	Validity bits for PTOK=NED 0 = Unused (not valid) 1 = Reserved 2 = Reserved 3 = Valid NED
116	(74)	CHARACTER	32	ND	Node Descriptor = CF PTOK
		111.		ND_VALID	Validity bits for PTOK=ND 0 = Valid, current 1 = Valid, not current 2 = Not valid
148	(94)	CHARACTER	4	*	Reserved
Entity Attribute Mask					
152	(98)	BITSTRING	4	EAM	
		1111		LOG_CLASS	Logical entity classification: 0 = Unspecified 1 = Host 2 = Chpid 3 = Switch 4 = Control unit 5 = Device 7 = Ambiguous (CHCU, etc) other values are reserved
	 1111		PHYS_CLASS	Physical entity classification: 0 = Unspecified 1 = Host 2 = Chpid 3 = Switch 4 = Control unit 5 = Device 6 = ESCON mod2 converter 7 = Ambiguous (link is static (no ND_ATT) and IODEF is ambiguous) 8 = CF internal path (only set for CUs) other values are reserved
153	(99)	BITSTRING	2	STATE	State of the entity
		1...		LOGICAL	1 = Entity is logical
		.1..		P_CURR	1 = Entity is physically current
		..1.		P_HIST	1 = Entity is physical history
		...1		LOG_OTHER	1 = Logical by another interface
	 1...		P_OTHER_CURR	1 = Physical by another interface
	1..		P_OTHER_HIST	1 = Physical history by other interface

Table 12. QUERY ENTITY CNTLUNIT Output (continued)

Offset							
Dec	Hex	Type	Len	Name(Dim)	Description		
	1.		P_INDIRECT	1 = The EAM validity was derived from the attached (ND) interfaces from the control unit		
	1		P_AMB	0 = The EAM validity was obtained from the CU itself (can only be true for opened switches)		
154	(9A)	1...		LOG_AMB	1 = Physical ambiguous configured on some interface		
		.1..		CLASS_AMB	1 = Logical ambiguous configured on some interface		
		..11 1111 >>		*	1 = Logical and physical classes are not compatible		
Reserved							
End of Entity Attribute Mask							
156	(9C)	CHARACTER	48	IODFDATA	Information from HCD		
156	(9C)	UNSIGNED	4	GROUP	Group class (encoded field)		
					1 = DASD		
					2 = Tape		
					3 = Cluster controller		
					4 = Communications controller		
					5 = MICR/OCR		
					6 = Graphics		
					7 = Unit record device		
					8 = Card reader/punch		
					9 = Display		
					10 = Term printer		
					255 = Other		
160	(A0)	CHARACTER	8	UNIT	Control Unit Type		
168	(A8)	CHARACTER	4	MODEL	Control Unit Model		
172	(AC)	CHARACTER	32	DESCRIPTION	HCD user description of this object		
204	(CC)	BITSTRING	1	SCPSTATE	For Coupling Facility only		
		1...		CONNECTED	1 = MVS allows operations		
		.1..		MANAGED	1 = MVS policy exists		
		..1.		AVAILABLE	1 = Physical path exists		
		...1		UNAVAILABLE	1 = No physical path		
	 1111		*	Reserved		
205	(CD)	CHARACTER	3	*	Reserved		
208	(D0)	CHARACTER	8	CFNAME	Coupling Facility name		
216	(D8)	CHARACTER	32	CU_LTOK	Logical Token (is binary zeros when not available)		
248	(F8)	CHARACTER	24	RESPONDER	Responding host ID		
248	(F8)	CHARACTER	8	APPLNAMER	VTAM application name or TCP/IP host name		
256	(100)	CHARACTER	8	SYSPLXR	Sysplex name		
264	(108)	CHARACTER	8	SYSTEMR	System name		
272	(110)	UNSIGNED	4	RCODE	Row return/reason code		
276	(114)	CHARACTER	8	*	Reserved		

QUERY ENTITY DEV

Purpose

Use the QUERY ENTITY DEV command at the API to obtain data about the specified device.

Query Parameters

►►—Query Entity Dev—| Entity_Object |—| Scope |—————►►

Output

The format of the output from QUERY ENTITY DEV is as follows:

Table 13. QUERY ENTITY DEV Output

Offset		Dec	Hex	Type	Len	Name(Dim)	Description
		0	(0)	STRUCTURE	*	QED	
The header for all Query Entity/Interface output structures is not listed here. Its size is 80 bytes. For details see "Common Output Header" on page 183.							
		80	(50)	CHARACTER	184	DEVS(*)	Individual device data
		80	(50)	UNSIGNED	2	DEV_NUMBER	Device number
		82	(52)	CHARACTER	1	STATBITS	
				1... ..		VALID_DATA	1 = This device is defined
				.1.. ..		DEV_IS_SWITCH	1 = This device is a switch
				..1.		DEV_IS_CF	1 = This device is a coupling facility
				...1		SELF_DESCR	1 = This device supports self-description
			 111.		*	Reserved
			1		TCPNAMER	1 = APPLNAMER contains the TCP/IP host name
Entity Attribute Mask							
		83	(53)	BITSTRING	4	EAM	
				1111		LOG_CLASS	Logical entity classification: 0 = Unspecified 1 = Host 2 = Chpid 3 = Switch 4 = Control unit 5 = Device 7 = Ambiguous (CHCU, etc) other values are reserved

Table 13. QUERY ENTITY DEV Output (continued)

Offset							
Dec	Hex	Type	Len	Name(Dim)	Description		
	 1111		PHYS_CLASS	Physical entity classification:		
					0 = Unspecified		
					1 = Host		
					2 = Chpid		
					3 = Switch		
					4 = Control unit		
					5 = Device		
					6 = ESCON mod2 converter		
					7 = Ambiguous (link is static (no ND_ATT) and IODEF is ambiguous)		
					8 = CF internal path (only set for CUs)		
					other values are reserved		
84	(54)	BITSTRING	2	STATE	State of the entity		
		1...		LOGICAL	1 = Entity is logical		
		.1..		P_CURR	1 = Entity is physically current		
		..1.		P_HIST	1 = Entity is physical history		
		...1		LOG_OTHER	1 = Logical by another interface		
	 1...		P_OTHER_CURR	1 = Physical by another interface		
	1..		P_OTHER_HIST	1 = Physical history by other interface		
	1.		P_INDIRECT	1 = The EAM validity was derived from the attached (ND) interfaces from the control unit		
					0 = The EAM validity was obtained from the CU itself (can only be true for opened switches)		
	1		P_AMB	1 = Physical ambiguous configured on some interface		
85	(55)	1...		LOG_AMB	1 = Logical ambiguous configured on some interface		
		.1..		CLASS_AMB	1 = Logical and physical classes are not compatible		
		..11 1111 >>		*	Reserved		
End of Entity Attribute Mask							
87	(57)	CHARACTER	20	*	Reserved		
107	(6B)	CHARACTER	24	RESPONDER	Responding host ID		
107	(6B)	CHARACTER	8	APPLNAMER	VTAM application name or TCP/IP host name		
115	(73)	CHARACTER	8	SYSPLXR	Sysplex name		
123	(7B)	CHARACTER	8	SYSTEMR	System name		
131	(83)	CHARACTER	1	*	Reserved		
132	(84)	UNSIGNED	4	RCODE	Row return/reason code		
136	(88)	CHARACTER	32	DEV_PTOK	Physical Token		
136	(88)	CHARACTER	32	NED	Node Element Descriptor		
168	(A8)	CHARACTER	6	VOLSER	Volume serial ID (DASD only, device NED indicates device type)		
174	(AE)	CHARACTER	2	*	Reserved		
176	(B0)	BITSTRING	4	SCPSTATE	Operating system state		
		1...		BOXED	1 = Boxed		
		.1..		NOTREADY	1 = Not ready		

QUERY ENTITY DEV

Table 13. QUERY ENTITY DEV Output (continued)

Offset							
Dec	Hex	Type	Len	Name(Dim)	Description		
		..1.		BUSY	1 = Busy		
		...1		RESERVED	1 = Reserved		
	 1...		ALLOCATED	1 = Allocated		
	1..		ONLINE	1 = Online		
	1.		UNLOAD	1 = Unload pending		
	1		MOUNT	1 = Mount pending		
177	(B1)	1...		RESPENDING	1 = Reserve pending		
		.1..		PENDING	1 = Pending offline		
		..1.		OFFALLOC	1 = Offline—allocated to SCP		
		...1		OFFESCM	1 = Offline due to I/O operations		
	 1...		OFFCUIR	1 = Offline due to CUIR		
	1..		OFFTAPE	1 = Offline due to tape		
	1.		OFFHIERCH	1 = Offline due to hierarchy reason		
	1		OFFOPER	1 = Offline due to operator		
178	(B2)	1...		OFFLINE	1 = Offline		
		.1..		INUSE	1 = Device is in use (message device only)		
		..1.		OPERATIONAL	1 = Device is operational (message device only)		
		...1		NOTOP	1 = Device is not operational (message device only)		
	 1...		AUTOSW	1 = Device is set autoswitch		
	111 >>		*	Reserved		
180	(B4)	CHARACTER	48	IODFDATA	HCD information		
180	(B4)	UNSIGNED	4	GROUP	Generic type encode:		
					1 = DASD		
					2 = Tape		
					3 = Cluster controller		
					4 = Communications controller		
					5 = MICR/OCR		
					6 = Graphics		
					7 = Unit record device		
					8 = Card reader/punch		
					9 = Display		
					10 = Term printer		
					255 = Other		
184	(B8)	CHARACTER	8	UNIT	Unit		
192	(C0)	CHARACTER	4	MODEL	Model		
196	(C4)	CHARACTER	32	DESCRIPTION	HCD user description data		
228	(E4)	CHARACTER	32	DEV_LTOK	Logical Token (is binary zeros when not available)		
260	(104)	CHARACTER	4	*	Reserved		

QUERY ENTITY HOST

Purpose

Use the QUERY ENTITY HOST command at the API to obtain data about one or more SA z/OS base programs (hosts) that are known to the issuing SA z/OS (primary host).

Query Parameters



Output

Output from a QUERY ENTITY command consists of a header, which is identical for each entity with the exception of the "Eye-Catcher" (offset 0), followed by the substructures, which are unique to each type of entity.

The format of the output from QUERY ENTITY HOST is as follows:

Table 14. QUERY ENTITY HOST Output

Offset					
Dec	Hex	Type	Len	Name(Dim)	Description
0	(0)	STRUCTURE	*	QEH	
The header for all Query Entity/Interface output structures is not listed here. Its size is 80 bytes. For details see "Common Output Header" on page 183.					
80	(50)	CHARACTER	208	HOSTS(*)	Individual host data
80	(50)	CHARACTER	8	APPL_NAME	VTAM application name
82	(52)	CHARACTER	1	STATBITS	
		1... ..		VALID_DATA	1 = This host is known
		.1.. ..		HOST_OFF	1 = This host is reset off
		..1.		IN_SESSION	For PRIMARY HOST only 1 = I/O operations/VTAM communication ok 0 = No I/O operations/VTAM communication
		...1		BACKING_OUT	For SECONDARY HOST only 1 = Appl-to-appl session ok 0 = No session setup
	 1...		IN_SESSION2	1 = Backout in progress 0 = No backout processing
	 1..		*	For PRIMARY HOST only: 1 = I/O operations/TCP communication ok 0 = No I/O operations/TCP communication
	1		TCPNAMER	Reserved 1 = APPLNAMER contains the TCP/IP host name
89	(59)	CHARACTER	4	VER_REL	SA z/OS version and release on this host
93	(5D)	CHARACTER	32	PID	This host PID (same format as in HDR)
Entity Attribute Mask					
125	(7D)	BITSTRING	4	EAM	
		1111		LOG_CLASS	Logical entity classification: 0 = Unspecified 1 = Host 2 = Chpid 3 = Switch 4 = Control unit 5 = Device 7 = Ambiguous (CHCU, etc) other values are reserved

QUERY ENTITY HOST

Table 14. QUERY ENTITY HOST Output (continued)

Offset							
Dec	Hex	Type	Len	Name(Dim)	Description		
	 1111		PHYS_CLASS	Physical entity classification:		
					0 = Unspecified		
					1 = Host		
					2 = Chpid		
					3 = Switch		
					4 = Control unit		
					5 = Device		
					6 = ESCON mod2 converter		
					7 = Ambiguous (link is static (no ND_ATT) and IODEF is ambiguous)		
					8 = CF internal path (only set for CUs)		
					other values are reserved		
126	(7E)	BITSTRING	2	STATE	State of the entity		
		1...		LOGICAL	1 = Entity is logical		
		.1..		P_CURR	1 = Entity is physically current		
		..1.		P_HIST	1 = Entity is physical history		
		...1		LOG_OTHER	1 = Logical by another interface		
	 1..		P_OTHER_CURR	1 = Physical by another interface		
	1..		P_OTHER_HIST	1 = Physical history by other interface		
	1.		P_INDIRECT	1 = The EAM validity was derived from the attached (ND) interfaces from the control unit		
					0 = The EAM validity was obtained from the CU itself (can only be true for opened switches)		
	1		P_AMB	1 = Physical ambiguous configured on some interface		
127	(7F)	1...		LOG_AMB	1 = Logical ambiguous configured on some interface		
		.1..		CLASS_AMB	1 = Logical and physical classes are not compatible		
		..11 1111 >>		*	Reserved		
End of Entity Attribute Mask							
129	(81)	CHARACTER	8	SYSPLEX	Sysplex name (blank if none)		
137	(89)	CHARACTER	8	SYSTEM	System name		
145	(91)	CHARACTER	24	RESPONDER	Responding host ID		
145	(91)	CHARACTER	8	APPLNAMER	VTAM application name or TCP/IP host name		
153	(99)	CHARACTER	8	SYSPLEXR	Sysplex name		
161	(A1)	CHARACTER	8	SYSTEMR	System name		
169	(A9)	CHARACTER	3	*	Reserved		
172	(AC)	UNSIGNED	4	RCODE	Row return/reason code		
176	(B0)	CHARACTER	64	HCD_DATA	HCD data		
176	(B0)	CHARACTER	44	IODF_DSN	HCD IODF dataset name		

Table 14. QUERY ENTITY HOST Output (continued)

Offset					
Dec	Hex	Type	Len	Name(Dim)	Description
220	(DC)	UNSIGNED	4	IODFACT	Hardware and software (CSS/IODF) synch status. Possible values: 1 = HW and SW of the active IODF are in sync 2 = HW and SW are out of sync 3 = No valid HW token exists
224	(E0)	CHARACTER	16	IODFNAME	World-wide unique name of the active configuration
240	(F0)	CHARACTER	16	LOCKOWNER	Process lock owner This field is only valid when this host is the same as the responding host. For other hosts, this field will be blank.
240	(F0)	CHARACTER	8	SYSTEML	Application name of user holding process lock
248	(F8)	CHARACTER	8	USER	Userid of lock owner
256	(100)	BITSTRING	1	R3_FNS	Additional functions installed beyond Release 3 1 = Byte Pacer. OSA, Downlevel MVS, no switch dependency are supported.
		1... ..		SPE1	
		.111 1111		*	Reserved
257	(101)	CHARACTER	3	OSLEVEL	Operating system
257	(101)	CHARACTER	1	NAME	M = MVS V = VM
258	(102)	CHARACTER	1	VERSION	Decimal 0-9
259	(103)	CHARACTER	1	RELEASE	Decimal 0-9
260	(104)	CHARACTER	8	CPUID	Processor ID (results of STIDP, will be blank when not set)
268	(10C)	UNSIGNED	2	CPUADD	Processor address (results of STADP, will be blank when not set)
270	(10E)		1	*	Reserved
271	(10F)	BITSTRING	1	COMMFLAGS	Communication flags
		1... ..		VTAMINSTALLED	1 = VTAM is installed on this host
		.1..		TCPINSTALLED	1 = TCP/IP is installed on this host
		..1.		IPV6ONLY	1 = TCP/IP supports only IPv6 on this host
272	(110)	CHARACTER	8	TCPHOSTNAME	TCP/IP host name
273	(118)	CHARACTER	8	*	Reserved

QUERY ENTITY SWITCH

Purpose

Use the QUERY ENTITY SWITCH command at the API to obtain data about the specified switch.

QUERY ENTITY SWITCH

Query Parameters

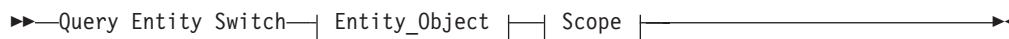

Output

The format of the output from QUERY ENTITY SWITCH is as follows:

Table 15. QUERY ENTITY SWITCH Output

Offset					
Dec	Hex	Type	Len	Name(Dim)	Description
0	(0)	STRUCTURE	*	QES	
The header for all Query Entity/Interface output structures is not listed here. Its size is 80 bytes. For details see "Common Output Header" on page 183.					
80	(50)	CHARACTER	192	SWITCHES(*)	Individual switch data
80	(50)	UNSIGNED	2	SW_DEVN	Switch device number
82	(52)	CHARACTER	1	STATBITS	
		1... ..		VALID_DATA	1 = This switch is in database
		.1.. ..		VALID_SWDEVN	1 = Switch device number valid
		..1.		*	Reserved
		...1		OPEN	1 = Switch is opened (by I/O operations)
	 1...		INVALID_LSN	1 = LSN is invalid
	11.		*	Reserved
	1		TCPNAMER	1 = APPLNAMER contains the TCP/IP host name
83	(53)	UNSIGNED	1	LSN	Logical switch number
84	(54)	CHARACTER	32	SW_PTOK	Physical Token
84	(54)	CHARACTER	32	NED	Node Element Descriptor
116	(74)	CHARACTER	32	PID	Unique (physical) ID (same format as in HDR)
148	(94)	UNSIGNED	1	NPINST	Number of installed ports
149	(95)	UNSIGNED	1	NPIM	Number of implemented ports (ports ABLE to be installed)
150	(96)	UNSIGNED	1	OP_STATUS	Operational status 0 = Unspecified 1 = Not open 2 = In contention 3 = H/W error 4 = System error 5 = I/O error 6 = Operational 7 = Reserved 8 = Read only (HCP set) Other values are reserved
151	(97)	UNSIGNED	1	A_CUP	CUP port address
152	(98)	UNSIGNED	4	STATUS_CODE	Error code (if any)
Entity Attribute Mask					
156	(9C)	BITSTRING	4	EAM	

Table 15. QUERY ENTITY SWITCH Output (continued)

Offset							
Dec	Hex	Type	Len	Name(Dim)	Description		
		1111		LOG_CLASS	Logical entity classification:		
					0 = Unspecified		
					1 = Host		
					2 = Chpid		
					3 = Switch		
					4 = Control unit		
					5 = Device		
					7 = Ambiguous (CHCU, etc)		
					other values are reserved		
	 1111		PHYS_CLASS	Physical entity classification:		
					0 = Unspecified		
					1 = Host		
					2 = Chpid		
					3 = Switch		
					4 = Control unit		
					5 = Device		
					6 = ESCON mod2 converter		
					7 = Ambiguous (link is static (no ND_ATT) and IODEF is ambiguous)		
					8 = CF internal path (only set for CUs)		
					other values are reserved		
157	(9D)	BITSTRING	2	STATE	State of the entity		
		1...		LOGICAL	1 = Entity is logical		
		.1..		P_CURR	1 = Entity is physically current		
		..1.		P_HIST	1 = Entity is physical history		
		...1		LOG_OTHER	1 = Logical by another interface		
	 1...		P_OTHER_CURR	1 = Physical by another interface		
	1..		P_OTHER_HIST	1 = Physical history by other interface		
	1.		P_INDIRECT	1 = The EAM validity was derived from the attached (ND) interfaces from the control unit		
					0 = The EAM validity was obtained from the CU itself (can only be true for opened switches)		
	1		P_AMB	1 = Physical ambiguous configured on some interface		
158	(9E)	1...		LOG_AMB	1 = Logical ambiguous configured on some interface		
		.1..		CLASS_AMB	1 = Logical and physical classes are not compatible		
		..11 1111 >>		*	Reserved		
End of Entity Attribute Mask							
160	(A0)	CHARACTER	32	IODFDESC	HCD's user description of this object		
192	(C0)	CHARACTER	7	ECLEVEL	Hardware EC level		
199	(C7)	UNSIGNED	1	LOWPORT	Lowest port address on this switch		
200	(C8)	BITSTRING	4	SCPSTATE	Operating system state		
		1...		BOXED	1 = Boxed		
		.1..		NOTREADY	1 = Not ready		
		..1.		BUSY	1 = Busy		

QUERY ENTITY SWITCH

Table 15. QUERY ENTITY SWITCH Output (continued)

Offset							
Dec	Hex	Type	Len	Name(Dim)	Description		
		...1		RESERVED	1 = Reserved		
	 1...		ALLOCATED	1 = Allocated		
	1..		ONLINE	1 = Online		
	1.		UNLOAD	1 = Unload pending		
	1		MOUNT	1 = Mount pending		
201	(C9)	1...		RESPENDING	1 = Reserve pending		
		.1..		PENDING	1 = Pending offline		
		..1.		OFFALLOC	1 = Offline—allocated to SCP		
		...1		OFFESCM	1 = Offline due to I/O operations		
	 1...		OFFCUIR	1 = Offline due to CUIR		
	1..		OFFTAPE	1 = Offline due to tape		
	1.		OFFHIERCH	1 = Offline due to hierarchy reason		
	1		OFFOPER	1 = Offline due to operator		
202	(CA)	1...		OFFLINE	1 = Offline		
		.1..		INUSE	1 = Device is in use (message device only)		
		..1.		OPERATIONAL	1 = Device is operational (message device only)		
		...1		NOTOP	1 = Device is not operational (message device only)		
	 1...		AUTOSW	1 = Device is set autoswitch		
	111 >>		*	Reserved		
204	(CC)	CHARACTER	32	SW_LTOK	Logical Token (inherited from CU for this switch—is binary zeros when not available)		
236	(EC)	CHARACTER	24	RESPONDER	Responding host ID		
236	(EC)	CHARACTER	8	APPLNAMER	VTAM application name or TCP/IP host name		
244	(F4)	CHARACTER	8	SYSPLEXR	Sysplex name		
252	(FC)	CHARACTER	8	SYSTEMR	System name		
260	(104)	UNSIGNED	4	RCODE	Row return/reason code		
264	(108)	CHARACTER	8	*	Reserved		

QUERY FILE

Purpose

Use the QUERY FILE command at the API to retrieve either a single saved switch configuration or a list of all the configurations saved at a switch returned to the caller in the IHVRESP or other user-designated response area. The switch must be allocated, or attached, to the issuing I/O operations.

Syntax

```

▶▶ Query File * [filename] swchdevn ▶▶

```

Parameters

- * Specify * to get a list of the saved switch configurations that are stored at the specified switch.

filename

Specify a file name in 1 through 8 valid EBCDIC codes to obtain a single saved configuration. Valid codes are uppercase alphabetical characters (A-Z), digital characters (0-9), and 2 special characters: the underscore (_) and the hyphen (-). However, the following file names are not valid: AUX, COM n (where $n=1-4$), CON, LPT n (where $n=1-3$), NUL, or PRN.

swchdevn

Specify the switch device number in up to 4 hexadecimal digits. The switch must be allocated, or attached, to the issuing I/O operations. You can use the Display Switch command to obtain a list of these switches.

Usage

- A maximum number of saved configurations can be stored at a switch. At an IBM Director, you can store 15 saved switch configurations. In addition, the IPL file can be loaded from, and restored at, the IBM Director. The IPL file is supplied with the unit and activated automatically when the Director is powered on.
- You can query the IPL file only if the Active=Save mode is disabled, which means when any changes being made to the active file are not being saved. (For the status of this mode, see the QFILAS field in the format of the output returned from Q F *)

Output

The format of the output from QUERY FILE *filename* is an array of 257 80-byte records. The data is returned in IHVRESP if the caller is a REXX EXEC and in a return area designated by the user if the caller is an assembler program.

- One 80-byte record is returned for each of the 256 ports that can be addressed. The format for these records is the same as given in "Output" on page 223.
- One 80-byte record is returned to identify the file in the following format:

Table 16. QUERY FILE Output of a Particular Configuration

Offset					
Dec	Hex	Type	Len	Name(Dim)	Description
0	(0)	CHARACTER	8	*	Reserved
8	(8)	CHARACTER	48	QFILBODY	Configuration file description (same format as below)
56	(38)	CHARACTER	24	*	Reserved

QUERY INTERFACE CNTLUNIT

Purpose

Use the QUERY INTERFACE CNTLUNIT command at the API to obtain data from the specified control unit regarding its interfaces.

Query Parameters

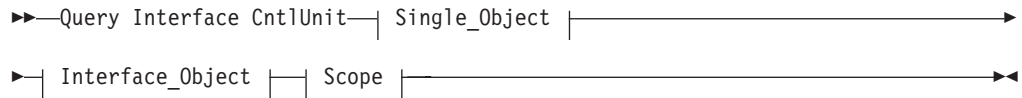

Parameters

The QUERY INTERFACE CONTROL UNIT command is designed to work only with ESCON control units because control unit interfaces are *physical* items and only ESCON control units support the architecture to return physical information. No IOCDS pathing information is used to obtain control unit interface responses unless a control specified is a coupling facility control unit. Only IOCDS pathing information is used to obtain the control unit interfaces.

The interface you specify in the command corresponds to the TAG (last 2 bytes, unsigned 2-byte value) field of the node descriptor (ND) associated with the control unit interface.

If the control unit you are querying is a dynamic switch, the interface you specify corresponds to the *port number* of the port that represents the interface.

- For *object_identifier*, specify the control unit number whose interfaces you want to query.
- For *interface_identifier*, specify a single physical interface for the specified control unit.
- Specify * if you want to receive data about all the physical interfaces for the specified control unit. Output array elements are sorted by the DTAG field.
For *Interface_identifier* with Range:
 - For *lower-upper*, specify an inclusive range of interfaces (or port numbers if the specified control unit is a switch control unit) on the specified control unit. Output array elements are sorted by the DTAG field.
 - Specify *lower-** if you want to receive data about the interfaces from the specified interface to (and including the highest interface. Output array elements are sorted by the DTAG field.

Output

The format of the output from the QUERY INTERFACE CONTROL UNIT command is as follows:

Table 17. QUERY INTERFACE CNTLUNIT Output

Offset					
Dec	Hex	Type	Len	Name(Dim)	Description
0	(0)	STRUCTURE	*	QIU	
The header for all Query Entity/Interface output structures is not listed here. Its size is 80 bytes. For details see "Common Output Header" on page 183.					
80	(50)	CHARACTER	312	INTERFACES(*)	CU interface descriptions
80	(50)	BITSTRING	1	VALID_DATA	1 = This element contains valid data
		1...			
		.111 111.		*	Reserved
	1		TCPNAMER	1 = APPLNAMER contains the TCP/IP host name
81	(51)	CHARACTER	7	*	Reserved

Table 17. QUERY INTERFACE CNTLUNIT Output (continued)

Offset					
Dec	Hex	Type	Len	Name(Dim)	Description
88	(58)	CHARACTER	32	ND_DET	Interface physical identity
120	(78)	CHARACTER	32	ND_ATT	Interface neighbor physical identity
Attached Entity Attribute Mask					
152	(98)	BITSTRING	4	AEAM	
		1111		LOG_CLASS	Logical entity classification: 0 = Unspecified 1 = Host 2 = Chpid 3 = Switch 4 = Control unit 5 = Device 7 = Ambiguous (CHCU, etc) other values are reserved
	 1111		PHYS_CLASS	Physical entity classification: 0 = Unspecified 1 = Host 2 = Chpid 3 = Switch 4 = Control unit 5 = Device 6 = ESCON mod2 converter 7 = Ambiguous (link is static (no ND_ATT) and IODEF is ambiguous) 8 = CF internal path (only set for CUs) other values are reserved
153	(99)	BITSTRING	2	STATE	State of the entity
		1...		LOGICAL	1 = Entity is logical
		.1..		P_CURR	1 = Entity is physically current
		..1.		P_HIST	1 = Entity is physical history
		...1		LOG_OTHER	1 = Logical by another interface
	 1...		P_OTHER_CURR	1 = Physical by another interface
	1..		P_OTHER_HIST	1 = Physical history by other interface
	1.		P_INDIRECT	1 = The attached ND for the entity being queried is history but we got the chpid's validity from the chpid's det ND (which is always valid) so the AEAM is marked P_CURR for the (attached) chpid 0 = The attached ND and AEAM have the same validity
	1		P_AMB	1 = Physical ambiguous configured on some interface
154	(9A)	1...		LOG_AMB	1 = Logical ambiguous configured on some interface
		.1..		CLASS_AMB	1 = Logical and physical classes are not compatible
		..11 1111 >>		*	Reserved
End of Attached Entity Attribute Mask					
Extrapolated entity descriptions					
156	(9C)	CHARACTER	36	OTHERS	

QUERY INTERFACE CNTLUNIT

Table 17. QUERY INTERFACE CNTLUNIT Output (continued)

Offset					
Dec	Hex	Type	Len	Name(Dim)	Description
156	(9C)	CHARACTER	32	ND	Extrapolation ND. This field is only valid when AEAM.P_OTHER or AEAM.P_OTHER_HIST are set (on). This ND can be expected to contain a value when either: <ul style="list-style-type: none"> • The PID and ND validities differ (and the validity of this thing better be the same as the PID if there is a PID) • There is more than 1 physical (only) path to an attached entity and the path that is being queried is not the most valid path—this ND should contain the identity of the more (most) valid (physical) path.
		111.		NDVALID	Indicates validity of this ND
		...1 1111		*	Not explicitly referenced
157	(9D)	CHARACTER	31	*	Rest of ND
188	(BC)	UNSIGNED	2	LOG	Extrapolated logical ID
					This is the lowest logically defined config number assigned to the entity. This field is only valid when AEAM.LOG_OTHER is set (on).
190	(BE)	CHARACTER	2	*	Reserved
End of extrapolated entity descriptions					
192	(C0)	CHARACTER	24	RESPONDER	Responding host ID
192	(C0)	CHARACTER	8	APPLNAMER	VTAM application name or TCP/IP host name
200	(C8)	CHARACTER	8	SYSPLXR	Sysplex name
208	(D0)	CHARACTER	8	SYSTEMR	System name
216	(D8)	UNSIGNED	4	RCODE	Row return/reason code
Control unit description					
220	(DC)	CHARACTER	168	CU	
220	(DC)	UNSIGNED	2	CU_NUMBER	Control unit number
222	(DE)	CHARACTER	1	STATBITS	
		1...		*	1 = CU is defined in the IOCDS
		.1..		CU_IS_SWITCH	1 = CU is a switch control unit
		..1.		CU_IS_CF	1 = CU is a coupling facility
		...1 1111		*	Reserved
223	(DF)	UNSIGNED	1	CUADD	IOCP logical address
224	(E0)	CHARACTER	32	PID	CU's derived physical identity
256	(100)	CHARACTER	32	CU_PTOK	Physical Token remaps the NED (when the CU_IS_CF bit is off) or is an ND (when the CU_IS_CF bit is on (=1)). See macro IXLMG for definition of the ND when the CU is a coupling facility.
256	(100)	CHARACTER	32	NED	Node Element Descriptor CU's physical ID read from the control unit when this CU is not a coupling facility

Table 17. QUERY INTERFACE CNTLUNIT Output (continued)

Offset							
Dec	Hex	Type		Len	Name(Dim)	Description	
		11..		NED_VALID	Validity bits for PTOK=NED 0 = Unused (not valid) 1 = Reserved 2 = Reserved 3 = Valid NED	
256	(100)	CHARACTER		32	ND	Node Descriptor = CF PTOK	
		111.		ND_VALID	Validity bits for PTOK=ND 0 = Valid, current 1 = Valid, not current 2 = Not valid	
288	(120)	CHARACTER		4	*	Reserved	
End of control unit description							
Entity Attribute Mask							
292	(124)	BITSTRING		4	EAM	Logical entity classification:	
		1111		LOG_CLASS	0 = Unspecified 1 = Host 2 = Chpid 3 = Switch 4 = Control unit 5 = Device 7 = Ambiguous (CHCU, etc) other values are reserved	
		1111		PHYS_CLASS	Physical entity classification: 0 = Unspecified 1 = Host 2 = Chpid 3 = Switch 4 = Control unit 5 = Device 6 = ESCON mod2 converter 7 = Ambiguous (link is static (no ND_ATT) and IODEF is ambiguous) 8 = CF internal path (only set for CUs) other values are reserved	
293	(125)	BITSTRING		2	STATE	State of the entity	
		1...		LOGICAL	1 = Entity is logical	
		.1..		P_CURR	1 = Entity is physically current	
		..1.		P_HIST	1 = Entity is physical history	
		...1		LOG_OTHER	1 = Logical by another interface	
		1...		P_OTHER_CURR	1 = Physical by another interface	
	1..		P_OTHER_HIST	1 = Physical history by other interface	
	1.		P_INDIRECT	1 = The EAM validity was derived from the attached (ND) interfaces from the control unit 0 = The EAM validity was obtained from the CU itself (can only be true for opened switches)	
	1		P_AMB	1 = Physical ambiguous configured on some interface	

QUERY INTERFACE CNTLUNIT

Table 17. QUERY INTERFACE CNTLUNIT Output (continued)

Offset					
Dec	Hex	Type	Len	Name(Dim)	Description
294	(126)	1... ..		LOG_AMB	1 = Logical ambiguous configured on some interface
		.1.. ..		CLASS_AMB	1 = Logical and physical classes are not compatible
		..11 1111 >>		*	Reserved
End of Entity Attribute Mask					
296	(128)	CHARACTER	48	IODFDATA	Information from HCD
296	(128)	UNSIGNED	4	GROUP	Group class (encoded field)
					1 = DASD
					2 = Tape
					3 = Cluster controller
					4 = Communications controller
					5 = MICR/OCR
					6 = Graphics
					7 = Unit record device
					8 = Card reader/punch
					9 = Display
					10 = Term printer
					255 = Other
300	(12C)	CHARACTER	8	UNIT	Control Unit Type
308	(134)	CHARACTER	4	MODEL	Control Unit Model
312	(138)	CHARACTER	32	DESCRIPTION	HCD user description of this object
344	(158)	BITSTRING	1	SCPSTATE	For Coupling Facility only
		1... ..		CONNECTED	1 = MVS allows operations
		.1.. ..		MANAGED	1 = MVS policy exists
		..1.		AVAILABLE	1 = Physical path exists
		...1		UNAVAILABLE	1 = No physical path
	 1111		*	Reserved
345	(159)	CHARACTER	3	*	Reserved
348	(15C)	CHARACTER	8	CFNAME	Coupling Facility name
356	(164)	CHARACTER	32	CU_LTOK	Logical token (is binary zeros when not available)
388	(184)	CHARACTER	4	*	Reserved

QUERY INTERFACE SWITCH

Purpose

Use the QUERY INTERFACE SWITCH command at the API to obtain data about the specified switch regarding its ports.

Query Parameters

►►—Query Interface Switch—| Single_Object |—| Interface_Object |—| Scope |—►►

Parameters

- For *object_identifier*, specify the switch device number that you want to receive data about.

- For *interface_identifier* or *, a single addressable port on the switch or * for all the addressable ports on the specified switch. Output array elements are sorted by port address. **Do not enclose the port address in parentheses for this command.**

For *Interface_identifier* with Range:

- For *lower-upper*, specify an inclusive range of port addresses on the specified switch. Output array elements are sorted by port address.
- Specify *lower-**, if you want to receive data on port addresses, starting with the specified address * to the highest implemented port address on the specified switch.
- When the CODE value in a row is set to 1, the PORTIN and PORTOUT columns of the table are queried.

Output

The format of the output from the QUERY INTERFACE SWITCH command is as follows:

Table 18. QUERY INTERFACE SWITCH Output

Offset					
Dec	Hex	Type	Len	Name(Dim)	Description
0	(0)	STRUCTURE	*	QIS	
The header for all Query Entity/Interface output structures is not listed here. Its size is 80 bytes. For details see "Common Output Header" on page 183.					
80	(50)	CHARACTER	360	PORTS(*)	Individual port data
80	(50)	UNSIGNED	1	PORT_NUMBER	Port Number
81	(51)	UNSIGNED	1	PORT_ADDRESS	Port Address (interface value)
82	(52)	BITSTRING	1		
		1...		VALID_DATA	1 = This PORTS element contains valid data
		.1..		MID_PORT	1 = This port is midport in chain
		..1.		CHAINED	1 = This port is chained
		...1 1...		DCM_STATE	0x = This port is not DCM eligible 10 = Port is DCM eligible but not allowed for DCM activities 11 = Port is eligible and allowed for DCM activities
	11.		*	Reserved
	1		TCPNAMER	1 = APPLNAMER contains the TCP/IP host name
83	(53)	CHARACTER	37	PIB	Port Information Block
83	(53)	BITSTRING	4	PDB	Port descriptors
		1...		UNIMPLEMENTED	1 = Unimplemented port
		.1..		BLOCKED	1 = Port is blocked
		..1.		SOME_PDCM_BIT_SET	1 = At least 1 prohibit
		...1		STATIC	1 = This port has static connection
	 1...		*	Reserved

QUERY INTERFACE SWITCH

Table 18. QUERY INTERFACE SWITCH Output (continued)

Offset							
Dec	Hex	Type	Len	Name(Dim)	Description		
	111		PORT_TECH	Indicates technology of port H/W		
					0 = Either port not installed or technology is unknown		
					1 = This is an internal port		
					3 = This port uses LED fiber		
					4 = This port uses LASER fiber technology		
					Other values are reserved		
84	(54)	1...		UNINSTALLED	1 = Port is not installed		
		.1..		LINK_FAIL	1 = Link failure (hardware fence)		
		..1.		SPARE	1 = This is a spare port		
		...1		OFFLINE	1 = Offline (hardware fence)		
	 1...		MAINT_MODE	1 = In diagnostic (maint) mode		
	1..		CUP	1 = This port is a CUP		
	1.		SERVICE	1 = Service required		
	1		CFG_ERR	1 = Invalid (ND) attachment		
85	(55)	1...		B_PORT	1 = This is a bridge port		
		.1..		PRT_NOTUSABLE	1 = Port number not usable		
		..1.		B_PRT_DEGRADED	1 = Bridge port degraded		
		...1 1...		*	Reserved		
	111		B_PRT_OFFL	>0 = Bridge port held offline		
86	(56)	1...		ERR_THRESHOLD	1 = Error threshold exceed		
		.111		PORT_TT	Transceiver technology valid if PORT_TECH=4:		
					0 = Unspecified		
					1 = GSM		
					2 = GLS		
					3 = GLX		
	 1...		*	Reserved		
	111		PORT_PT	Protocol type:		
					0 = ESCON		
					1 = Reserved		
					2 = FICON Bridge		
					3 = FICON Fabric		
					4 = FICON E-Port		
					5 = FICON L-Port		
					6 = FICON G-Port		
87	(57)	UNSIGNED	1	OTHER_STATIC_PORT	Port that this port is connected to (on same switch)		
88	(58)	BITSTRING	32	PDCM	Prohibit Dynamic Connectivity Mask		
					0 = Communication is allowed		
					1 = Communication is not allowed		
120	(78)	CHARACTER	24	LNAME	Port logical name		

Table 18. QUERY INTERFACE SWITCH Output (continued)

Offset					
Dec	Hex	Type	Len	Name(Dim)	Description
144	(90)	UNSIGNED	1	IODEF	Port "type" 0 = Unspecified 1 = CH (channel) 2 = CU 3 = CHCU 4 = CHCH 5 = PC 6 = PCCU other values are reserved
145	(91)	CHARACTER	3	*	Reserved
148	(94)	CHARACTER	32	ND_DET	Determined ND—"who am I"
180	(B4)	CHARACTER	32	ND_ATT	Attached ND—"who are you"
End of switch description					
Attached Entity Attribute Mask					
212	(D4)	BITSTRING	4	AEAM	
		1111		LOG_CLASS	Logical entity classification: 0 = Unspecified 1 = Host 2 = Chpid 3 = Switch 4 = Control unit 5 = Device 7 = Ambiguous (CHCU, etc) other values are reserved
	 1111		PHYS_CLASS	Physical entity classification: 0 = Unspecified 1 = Host 2 = Chpid 3 = Switch 4 = Control unit 5 = Device 6 = ESCON mod2 converter 7 = Ambiguous (link is static (no ND_ATT) and IODEF is ambiguous) 8 = CF internal path (only set for CUs) other values are reserved
213	(D5)	BITSTRING	2	STATE	State of the entity
		1...		LOGICAL	1 = Entity is logical
		.1..		P_CURR	1 = Entity is physically current
		..1.		P_HIST	1 = Entity is physical history
		...1		LOG_OTHER	1 = Logical by another interface
	 1...		P_OTHER_CURR	1 = Physical by another interface
	1..		P_OTHER_HIST	1 = Physical history by other interface

QUERY INTERFACE SWITCH

Table 18. QUERY INTERFACE SWITCH Output (continued)

Offset							
Dec	Hex	Type	Len	Name(Dim)	Description		
	1.		P_INDIRECT	1 = The attached ND for the entity being queried is history but we got the chpid's validity from the chpid's det ND (which is always valid) so the AEAM is marked P_CURR for the (attached) chpid		
	1		P_AMB	0 = The attached ND and AEAM have the same validity		
214	(D6)	1...		LOG_AMB	1 = Physical ambiguous configured on some interface		
		.1..		CLASS_AMB	1 = Logical ambiguous configured on some interface		
		..11 1111 >>		*	1 = Logical and physical classes are not compatible		
Reserved							
End of Attached Entity Attribute Mask							
Extrapolated entity descriptions							
216	(D8)	CHARACTER	36	OTHERS			
216	(D8)	CHARACTER	32	ND	Extrapolation ND. This field is only valid when AEAM.P_OTHER or AEAM.P_OTHER_HIST are set (on). This ND can be expected to contain a value when either:		
					<ul style="list-style-type: none"> The PID and ND validities differ (and the validity of this thing better be the same as the PID if there is a PID) There is more than 1 physical (only) path to an attached entity and the path that is being queried is not the most valid path—this ND should contain the identity of the more (most) valid (physical) path. 		
		111.		NDVALID	Indicates validity of this ND		
		...1 1111		*	Not explicitly referenced		
217	(D9)	CHARACTER	31	*	Rest of ND		
248	(F8)	UNSIGNED	2	LOG	Extrapolated logical ID		
					This is the lowest logically defined config number assigned to the entity. This field is only valid when AEAM.LOG_OTHER is set (on).		
250	(FA)	CHARACTER	2	*	Reserved		
End of extrapolated entity descriptions							
252	(FC)	CHARACTER	24	RESPONDER	Responding host ID		
252	(FC)	CHARACTER	8	APPLNAMER	VTAM application name or TCP/IP host name		
260	(104)	CHARACTER	8	SYSPLEXR	Sysplex name		
268	(10C)	CHARACTER	8	SYSTEMR	System name		
276	(114)	UNSIGNED	4	RCODE	Row return/reason code		
Switch description							
280	(118)	CHARACTER	156	SWITCH	Switch description (entity1)		

Table 18. QUERY INTERFACE SWITCH Output (continued)

Offset					
Dec	Hex	Type	Len	Name(Dim)	Description
280	(118)	UNSIGNED	2	SW_DEVN	Switch device number
282	(11A)	CHARACTER	1	STATBITS	
		1... ..		VALID_DATA	1 = This switch is in database
		.1.. ..		VALID_SWDEVN	1 = Switch device number valid
		..1.		*	Reserved
		...1		OPEN	1 = Switch is opened (by I/O operations)
	 1...		INVALID_LSN	1 = LSN is invalid
	111		*	Reserved
283	(11B)	UNSIGNED	1	LSN	Logical switch number
284	(11C)	CHARACTER	32	SW_PTOK	Physical Token
284	(11C)	CHARACTER	32	NED	Node Element Descriptor
316	(13C)	CHARACTER	32	PID	Unique (physical) ID (same format as in HDR)
348	(15C)	UNSIGNED	1	NPINST	Number of installed ports
349	(15D)	UNSIGNED	1	NPIM	Number of implemented ports (ports ABLE to be installed)
350	(15E)	UNSIGNED	1	OP_STATUS	Operational status 0 = Unspecified 1 = Not open 2 = In contention 3 = H/W error 4 = System error 5 = I/O error 6 = Operational 7 = Reserved 8 = Read only (HCP set) Other values are reserved
351	(15F)	UNSIGNED	1	A_CUP	CUP port address
352	(160)	UNSIGNED	4	STATUS_CODE	Error code (if any)
End of switch description					
Entity Attribute Mask					
356	(164)	BITSTRING	4	EAM	
		1111		LOG_CLASS	Logical entity classification: 0 = Unspecified 1 = Host 2 = Chpid 3 = Switch 4 = Control unit 5 = Device 7 = Ambiguous (CHCU, etc) other values are reserved

QUERY INTERFACE SWITCH

Table 18. QUERY INTERFACE SWITCH Output (continued)

Offset							
Dec	Hex	Type	Len	Name(Dim)	Description		
	 1111		PHYS_CLASS	Physical entity classification:		
					0 = Unspecified		
					1 = Host		
					2 = Chpid		
					3 = Switch		
					4 = Control unit		
					5 = Device		
					6 = ESCON mod2 converter		
					7 = Ambiguous (link is static (no ND_ATT) and IODEF is ambiguous)		
					8 = CF internal path (only set for CUs)		
					other values are reserved		
357	(165)	BITSTRING	2	STATE	State of the entity		
		1...		LOGICAL	1 = Entity is logical		
		.1..		P_CURR	1 = Entity is physically current		
		..1.		P_HIST	1 = Entity is physical history		
		...1		LOG_OTHER	1 = Logical by another interface		
	 1...		P_OTHER_CURR	1 = Physical by another interface		
	1..		P_OTHER_HIST	1 = Physical history by other interface		
	1.		P_INDIRECT	1 = The EAM validity was derived from the attached (ND) interfaces from the control unit		
					0 = The EAM validity was obtained from the CU itself (can only be true for opened switches)		
	1		P_AMB	1 = Physical ambiguous configured on some interface		
358	(166)	1...		LOG_AMB	1 = Logical ambiguous configured on some interface		
		.1..		CLASS_AMB	1 = Logical and physical classes are not compatible		
		..11 1111 >>		*	Reserved		
End of Entity Attribute Mask							
360	(168)	CHARACTER	32	IODFDESC	HCD's user description of this object		
392	(188)	CHARACTER	7	ECLEVEL	Hardware EC level		
399	(18F)	UNSIGNED	1	LOWPORT	Lowest port address on this switch		
400	(190)	BITSTRING	4	SCPSTATE	Operating system state		
		1...		BOXED	1 = Boxed		
		.1..		NOTREADY	1 = Not ready		
		..1.		BUSY	1 = Busy		
		...1		RESERVED	1 = Reserved		
	 1...		ALLOCATED	1 = Allocated		
	1..		ONLINE	1 = Online		
	1.		UNLOAD	1 = Unload pending		
	1		MOUNT	1 = Mount pending		
401	(191)	1...		RESPENDING	1 = Reserve pending		
		.1..		PENDING	1 = Pending offline		
		..1.		OFFALLOC	1 = Offline—allocated to SCP		

Table 18. QUERY INTERFACE SWITCH Output (continued)

Offset							
Dec	Hex	Type	Len	Name(Dim)	Description		
		...1		OFFESCM	1 = Offline due to I/O operations		
	 1...		OFFCUIR	1 = Offline due to CUIR		
	1..		OFFTAPE	1 = Offline due to tape		
	1.		OFFHIERCH	1 = Offline due to hierarchy reason		
	1		OFFOPER	1 = Offline due to operator		
402	(192)	1...		OFFLINE	1 = Offline		
		.1..		INUSE	1 = Device is in use (message device only)		
		..1.		OPERATIONAL	1 = Device is operational (message device only)		
		...1		NOTOP	1 = Device is not operational (message device only)		
	 1...		AUTOSW	1 = Device is set autoswitch		
	111 >>		*	Reserved		
404	(194)	CHARACTER	32	SW_LTOK	Logical Token (inherited from CU for this switch—is binary zeros when not available)		
436	(1B4)	CHARACTER	4	*	Reserved		

QUERY RELATION CHP

Purpose

Use the QUERY RELATION CHP command at the API to obtain data regarding the IOCDS relationship between the two specified entities (objects). Output is based on IOCDS definitions, but it can be influenced by configuration mismatches that have been detected by I/O operations.

Query Parameters

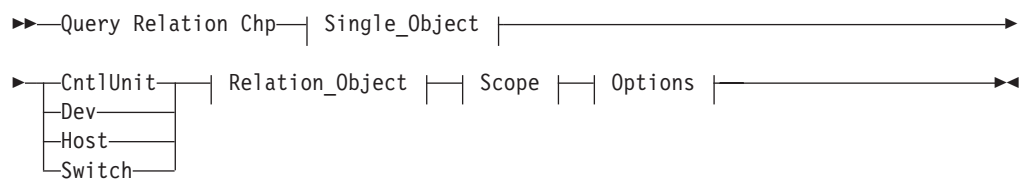

Parameters

- This command returns data about the logical relationships (in IOCDS) between the first entity, which is a single CHPID, and the second entity or entities.
- For a QUERY RELATION command, the first entity (host name) must be known to the issuing I/O operations (primary host). The command returns an indication whether the specified CHPID is defined in IOCDS to the issuing I/O operations.
- If you specify switches as the second entity, the command returns an indication whether the CHPID in the first entity has defined paths through the switches.

QUERY RELATION CNTLUNIT

Purpose

Use the QUERY RELATION CNTLUNIT command at the API to obtain data regarding the IOCDS relationship between the two specified entities (objects). Output is based on IOCDS definitions, but it can be influenced by configuration mismatches that have been detected by I/O operations.

Query Parameters

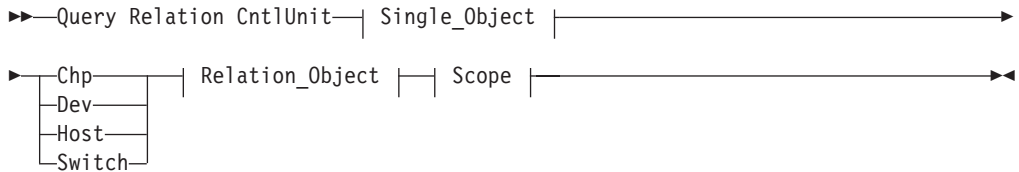

Parameters

- This command returns data about the relationships between the specified control unit and the second entity in the command.
- If the second entity is Host and the issuing I/O operations is included in the parameters, this command returns indications of what CHPIDs have (IOCDS) defined paths to the control unit specified in the first entity.
- If the second entity is Host and a voting I/O operations is included in the parameters, this command returns only an indication that the I/O operations (secondary host) known to the issuing I/O operations. No pathing data can be returned.
- If the second entity is Chp, the command returns indications of whether the specified CHPIDs have (IOCDS) defined paths to the specified control unit for the issuing I/O operations (primary host).
- If the second entity is Switch, the command returns indications of whether the control unit specified has (IOCDS) defined paths through the specified switch(es) for the issuing I/O operations.
- If the second entity is Dev, the command returns indications of whether the specified control unit has (IOCDS) defined paths through the specified devices for the issuing I/O operations.

QUERY RELATION DEV

Purpose

Use the QUERY RELATION DEV command at the API to obtain data regarding the IOCDS relationship between the two specified entities (objects). Output is based on IOCDS definitions, but it can be influenced by configuration mismatches that have been detected by I/O operations.

Query Parameters

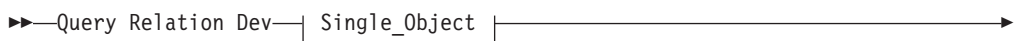

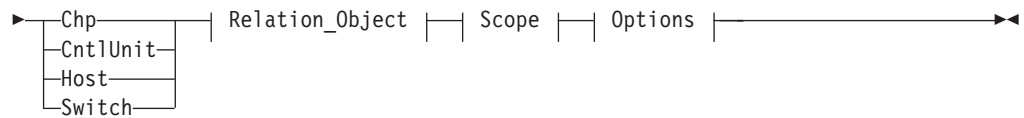

Parameters

- This command returns data about the relationships between the specified device and the second entity in the command.
- If the second entity is Host and the issuing I/O operations is specified, the command returns indications of whether the device has (IOCDS) defined paths to that host. If a voting I/O operations is specified, an indication is returned that the host is known, but pathing information is not available.
- If the second entity is Chp, the command returns indications of whether the specified device has (IOCDS) defined paths to the specified CHPID(s).
- If the second entity is Switch, the command returns indications of whether the control unit specified has (IOCDS) defined paths through the specified switch(es) for the issuing I/O operations.
- If the second entity is CntlUnit, the command returns indications of whether the specified control unit(s) have (IOCDS) defined paths through them to the specified device for the issuing I/O operations.

Notes:

1. When ARRAY is the *Object_format_type*, the *Object_Identifier_Types* can be mixed and every *Object_Identifier_Type* must match the class of the specified *Object_Type* (all must be I/O_resources or all must be Hosts). For example, Q E HOST can accept only HOST and XSYS entries in the array.
2. The Array_header contains the number of elements in the array.
3. PTOK is valid with RANGE but you should be fully aware of PTOK structure. For example, RANGE PTOK could be used to specify all of the serial numbers of a certain type of device. However, certain PTOK values may cause unpredictable results with RANGE.
4. When ARRAY is the *SCOPE_format_type*, the *Host_Object_Identifier_Types* can be mixed (HOST and XSYS).
5. If you need to translate a QUERY RELATION command to a new format due to an overflow condition reported by a return code and reason code, you may need to begin the new command with the *last* value that was returned or some pathing information could be lost.

QUERY RELATION HOST

Purpose

Use the QUERY RELATION HOST command at the API to obtain data regarding the IOCDS relationship between the two specified entities (objects). Output is based on IOCDS definitions, but it can be influenced by configuration mismatches that have been detected by I/O operations.

Query Parameters

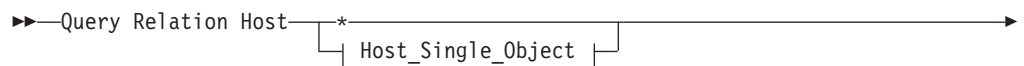

QUERY RELATION HOST

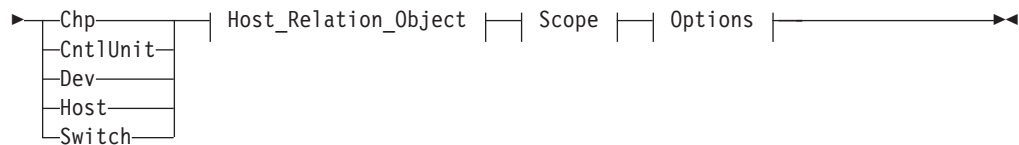

Parameters

- For a QUERY RELATION command, the first entity (host name) must be known to the issuing I/O operations (primary host).
- For Q R H S, you can specify any I/O operations that participates in vary path consensus processing initiated by the issuing I/O operations. However, data indicating CHPID attachments to the switches is returned only for the issuing I/O operations

Notes:

1. When ARRAY is the *Object_format_type*, the *Object_Identifier_Types* can be mixed and every *Object_Identifier_Type* must match the class of the specified *Object_Type* (all must be I/O_resources or all must be Hosts). For example, Q E HOST can accept only HOST and XSYS entries in the array.
2. The Array_header contains the number of elements in the array.
3. PTOK is valid with RANGE but you should be fully aware of PTOK structure. For example, RANGE PTOK could be used to specify all of the serial numbers of a certain type of device. However, certain PTOK values may cause unpredictable results with RANGE.
4. When ARRAY is the *SCOPE_format_type*, the *Host_Object_Identifier_Types* can be mixed (HOST and XSYS).

QUERY RELATION SWITCH

Purpose

Use the QUERY RELATION SWITCH command at the API to obtain data regarding the IOCDS relationship between the two specified entities (objects). Output is based on IOCDS definitions, but it can be influenced by configuration mismatches that have been detected by I/O operations.

Query Parameters

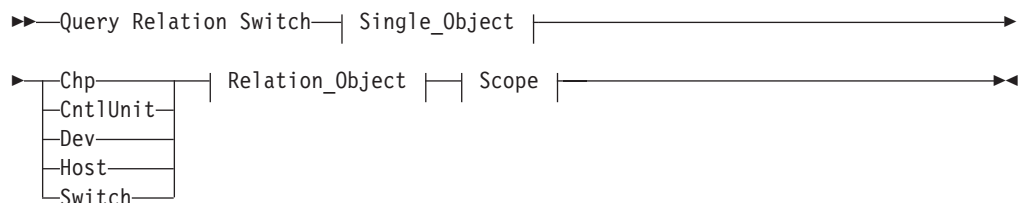

Parameters

- This command returns data about the relationships between the specified switch and the second entity in the command.
- If you specify the issuing I/O operations (host) as the second entity, 1 ROW is returned for each channel that I/O operations perceives as being connected to

the switch. (If the physical settings at the switch indicate differently from the IOCDS, I/O operations "perceives" the physical settings to be accurate.)

If the switch specifies the destination switch of a cascaded switch pair, the relationship will return one row for each CHP that defines a path to the CUP device of the switch with the following differing information:

- The output port information shows X'FE' indicating the CUP device of a cascaded switch
- If you specify a voting I/O operations (host) as the second entity, only 1 ROW is returned, indicating that the host is able to communicate with, and control, the switch. No CHPIDs are returned, and the incomplete bit is set for that host.
- If you specify CHP as the second entity, the command returns indications of what channel(s) are defined in IOCDS to be attached to the switch. To obtain data on what channels are defined to communicate with a switch, specify Q R CU C, specifying the control unit port, or the Q R D C, specifying the switch device number.
- If you specify Switch as the second entity, the command returns indications:
 - Of what chains have been established with the first entity (ESCON only)
 - Whether both switches build the entry and destination switch of any path defined (FICON only)
- If you specify CntlUnit or Dev as the second entity, the command returns indications whether the specified switch has IOCDS-defined paths through it to the specified control units or devices.

QUERY SWITCH

Purpose

Use the QUERY SWITCH command at the API to obtain an array of port information blocks (PIBs) and related data from the specified switch.

Syntax

►►—Query Switch—*swchdevn*—◄◄

Parameters

swchdevn

Specifies the switch to be queried. The switch must be allocated to, or attached to, the issuing I/O operations. Refer to *IBM Tivoli System Automation for z/OS Operator's Commands* for further information about switches.

Output

The data is presented as an array of 80-byte entries, as shown below. 256 entries are returned. (The first array is for port address 00.)

Table 19. QUERY SWITCH Output

Offset					
Dec	Hex	Type	Len	Name(Dim)	Description
0	(0)	STRUCTURE	80	QSWT	
0	(0)	BITSTRING	1	QSWTFLAG1	Flags byte 1

QUERY SWITCH

Table 19. QUERY SWITCH Output (continued)

Offset							
Dec	Hex	Type	Len	Name(Dim)	Description		
		1... ..		QSWTLAST	End of list indicator		
					0 = More records		
					1 = Last record in array		
		.1.. ..		QSWTMDPT	Midport		
					1 = This port is the midport of a defined chain		
		..11 ..		QSWTFORM	Format ID		
				*	0 = Format 0 (original format)		
	 1111		*	Reserved		
1	(1)	BITSTRING	1	QSWTFLAG2	Flags byte 2		
		1111 11..		*	Reserved		
	11		QSWT_DCM_STATE	0x = Port not DCM eligible		
					10 = Port DCM eligible but not allowed for DCM activities		
					11 = Port DCM eligible and allowed for DCM activities		
2	(2)	UNSIGNED	2	QSWTSWIT	Switch device number		
4	(4)	CHARACTER	48	QSWTLAIB	Port information block		
4	(4)	CHARACTER	1	*	Reserved		
5	(5)	UNSIGNED	1	LAIBNUMB	Port number		
6	(6)	UNSIGNED	1	LAIBADDR	Port address		
7	(7)	CHARACTER	1	*	Reserved		
8	(8)	BITSTRING	4	LAIBDESC	Port descriptors		
		1... ..		LAIBUNMP	Port implementation		
					0 = Port is implemented		
					1 = Port is not implemented		
		.1.. ..		LAIBFBIT	Port fence information		
					0 = Port is not blocked		
					1 = Port is blocked		
		..1.		LAIBIC	Prohibit port connection		
					0 = No prohibits for this port		
					1 = Prohibits defined		
		...1		LAIBSBIT	Port connection		
					0 = Port is not connected		
					1 = Port is connected		
	 1...		*	Reserved		
	111		LAIBLED	Port hardware		
					0 = Unspecified		
					1 = Internal		
					2 = Electrical		
					3 = LED fiber optic		
					4 = Laser fiber optic		
9	(9)	1... ..		LAIBNBIT	1 = Not installed		
		.1.. ..		LAIBLFBIT	1 = Link failure		
		..1.		LAIBSP	1 = Swapped port		
		...1		LAIBOLBIT	1 = Offline		
	 1...		LAIBDMBIT	1 = Port in maintenance mode		
	1..		LAIBCUPBIT	1 = This port is a CUP		
	1.		LAIBSERVICE	1 = Service required		
	1		LAIBINVATT	1 = Port has an invalid attachment		
10	(A)	1... ..		LAIBBRGPRT	1 = This is a bridge port		
		.1.. ..		LAIBPRTNUU	1 = Port number not usable		
		..1.		LAIBBPDEG	1 = Bridge port degraded		

Table 19. QUERY SWITCH Output (continued)

Offset							
Dec	Hex	Type	Len	Name(Dim)	Description		
		...1 1...		*	Reserved		
	111		LAIBBPOFF	>0 =		Bridge port held offline
11	(B)	1...		LAIBETE	1 =		Error threshold exceeded
		.111		LAIBTT			Transeiver technology
					0 =		Unspecified
					1 =		GSM
					2 =		GLS
					3 =		GLX
	 1...		*	Reserved		
	111		LAIBPT	Protocol type:		
					0 =		ESCON
					1 =		Reserved
					2 =		FICON Bridge
					3 =		FICON Fabric
					4 =		FICON E-Port
					5 =		FICON L-Port
					6 =		FICON G-Port
12	(C)	CHARACTER	1	*	Reserved		
13	(D)	UNSIGNED	1	LAIBESVR	Number of ESCON server ports		
14	(E)	UNSIGNED	1	LAIBSADR	Static connection address		
15	(F)	CHARACTER	5	*	Reserved		
20	(14)	BITSTRING	32	LAIBICM	Port prohibit dynamic connection mask (PDCM)		
52	(34)	CHARACTER	24	QSWTNAME	Port logical name		
76	(4C)	UNSIGNED	2	QSWTCSWIT	Switch device number for chained device		
78	(4E)	UNSIGNED	1	QSWTCPORT	Chained port address		
79	(4F)	CHARACTER	1	*	Reserved		

Examples

Note: If a port is not implemented, only the switch number, port address, and unimplemented bit contain valid data; all other fields are set to binary zeros.

The following sample output shows that port address *F3* has been assigned port name *0500X0600*. It is statically connected to port address *E1* on switch device number *0500*. As one would expect from the port name, port address *F3* is chained to port address *D0* on switch device number *0600*.

REMOVE and RESTORE CHP

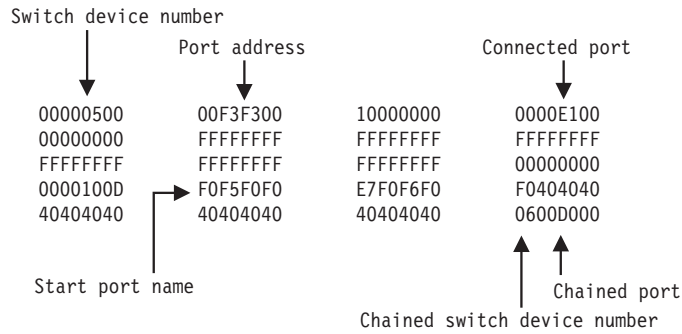

Figure 12. QUERY SWITCH Command - Sample Output.

REMOVE and RESTORE CHP

Purpose

Use the REMOVE CHP command at the I/O operations API to configure a chpid or chpids offline to one or more hosts.

Use the RESTORE CHP command at the I/O operations API to configure a chpid or chpids online to one or more hosts.

Syntax

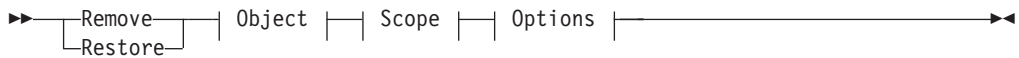

Object:



Object_format

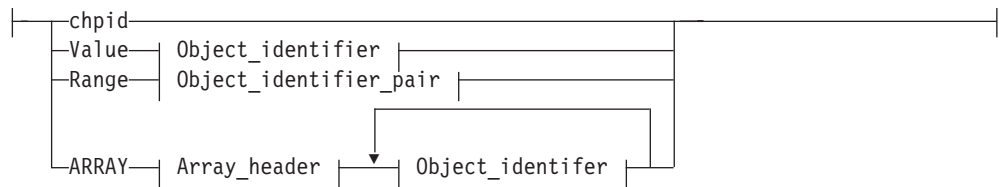

Object_identifier:

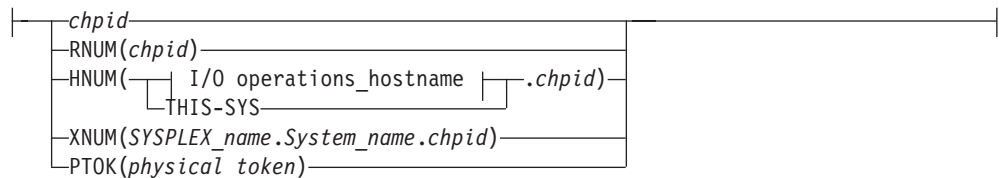

Object_identifier_pair:

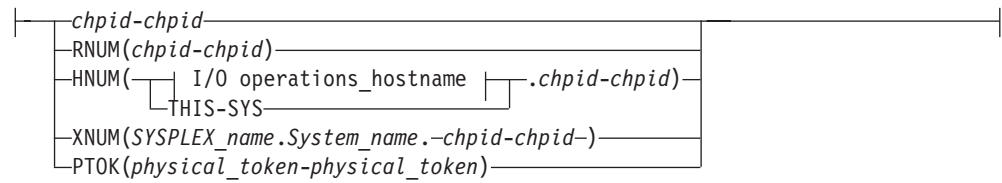

Scope:

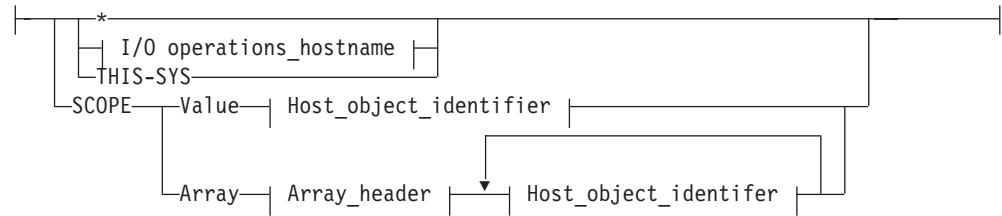

Host_object_identifier:

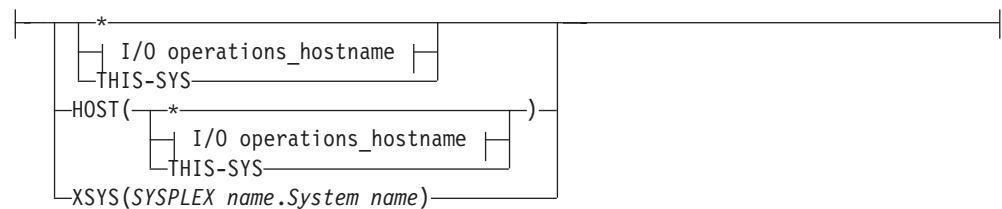

I/O operations_hostname:

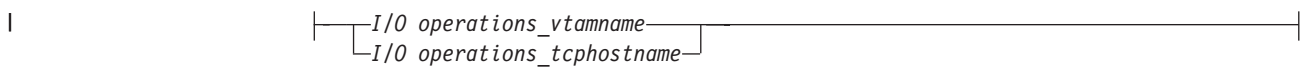

Options:

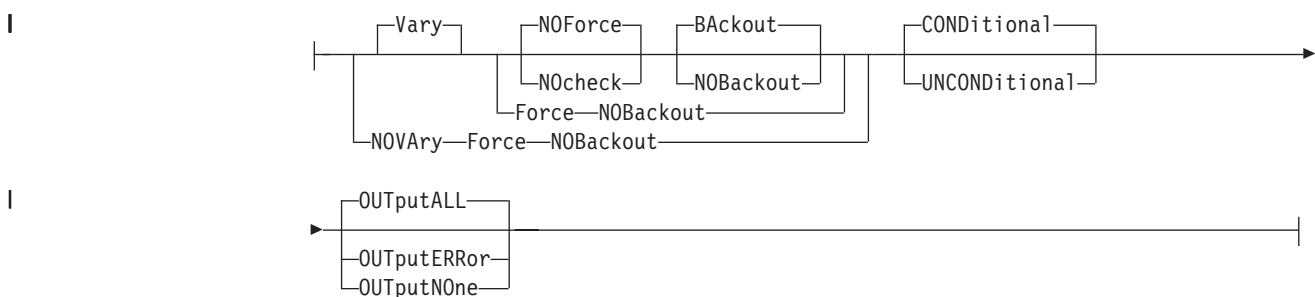

Parameters

A host identifier type can be one of the following keywords:

Vary

This is the default option and it indicates that appropriate processing must be done at the host to support the REMOVE and RESTORE CHP commands.

REMOVE and RESTORE CHP

NOVary

This option is not valid for the REMOVE and RESTORE CHP commands.

Force

This option says to execute the command in the best manner possible. For example, if one of the specified hosts does not respond, the command is still performed on all other hosts.

NOForce

This is the default option and indicates that if there is any failure, the command should not continue and a return and reason describing the failure will be returned.

NOCheck

The NOCheck option overrides the detection of two conditions that would cause the failure of the command under the default NOForce option:

1. Detection of systems in the scope of the command that I/O operations is not operating on
2. Detection of downlevel I/O operations's operating on systems in the scope of the command

If either of these conditions is detected, a return code of 4 is returned.

Backout

This is the default option and indicates that if any failure is reported by any of the participating systems, any successful REMOVE and RESTORE CHP actions for all the participating host systems will be backed out.

NOBackout

This option indicates that if any error condition is detected during the REMOVE and RESTORE CHP processing, I/O operations will not attempt to change any REMOVE and RESTORE CHP actions that have been performed.

CONDitional

This is the default option for both the REMOVE and RESTORE CHP commands. It indicates that no special configure offline or configure online action should be performed.

UNCONDitional

For the REMOVE CHP command, this option puts the specified chpids immediately into pending offline status, even if the chpids are currently active, allocated, or reserved.

For the RESTORE CHP command, this option brings the specified chpids online, even if there are no paths to the chpids, or if the chpids are pending offline and boxed.

OUTputALL

This is the default and it allows all results from REMOVE and RESTORE CHPs performed (regardless of return code) to be returned to the API invoker.

OUTputERRor

This option allows only error results (REMOVE and RESTORE CHPs that had a return code ≥ 4 , plus other errors that occurred during the processing of the command) to be returned to the API invoker.

OUTputNOne

This option allows only the return and reason code (no text information) to be returned to the API invoker. If the return code from the command is ≥ 4 , a detailed message (IHVC00I, IHVC001I, or IHVC002I) is also returned.

Notes:

1. This form, with no keyword, is supported for compatibility with the previously existing syntax of this command.
2. ARRAY has no short form for this command (in other multisystem commands A is used as a short form). That is to avoid the need to look ahead in parsing "Remove Chp A..." to distinguish between removing the CHP with ID 'A' and removing an array of CHPs.
3. In this command, THIS-SYS is a means to refer to the primary host (the one that the command is being input to). It is accepted by the primary regardless of whether VTAM is operational or not.
4. When ARRAY is the *Object_format_type*, the *Object_Identifier_Types* may be mixed (for example, HOST and XSYS), and every *Object_Identifier_Type* must be an I/O resource type. For example, an HNUM and an XNUM entry can be in the same array.
5. The Array_header contains the number of elements in the array.
6. PTOK is valid with RANGE but you should be fully aware of PTOK structure. Certain PTOK values may cause unpredictable results with RANGE
7. When ARRAY is the *SCOPE_format_type*, the *Host_Object_Identifier_Types* may be mixed (for example, HOST and XSYS).

REMOVE DEV and RESTORE DEV

Purpose

Use the REMOVE DEV command at the I/O operations API to configure a device or devices offline to one or more hosts.

Use the RESTORE DEV command at the I/O operations API to configure a device or devices online to one or more hosts.

Syntax

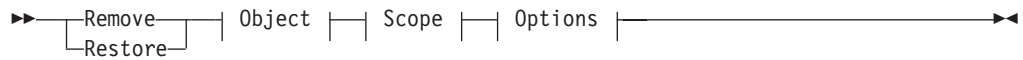

Object:

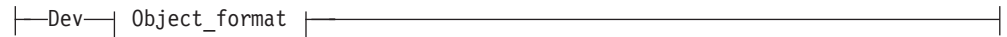

Object_format

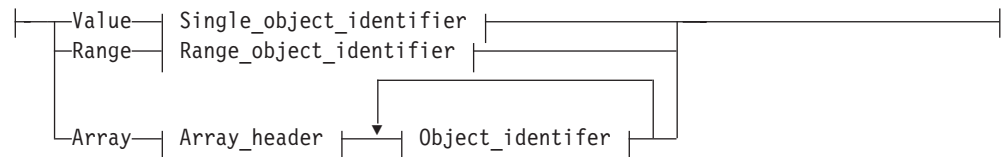

Single_object_identifier:

REMOVE DEV and RESTORE DEV

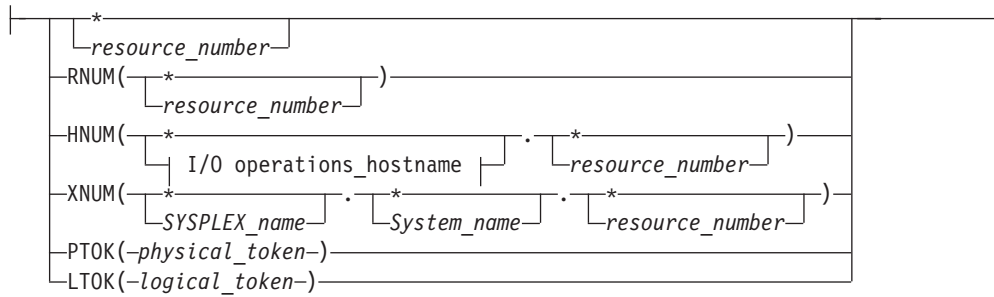

Range_object_identifier:

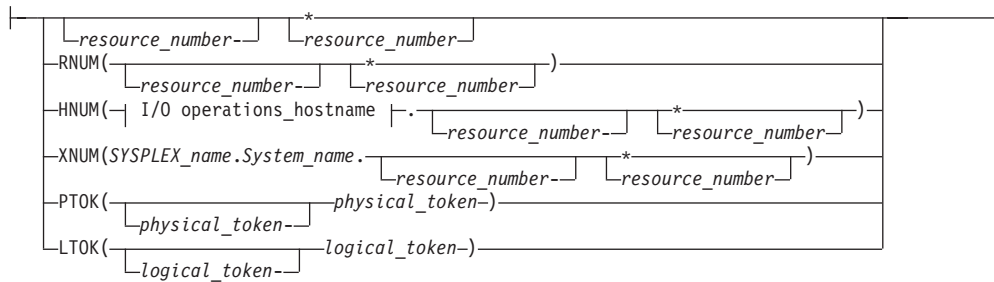

Scope:

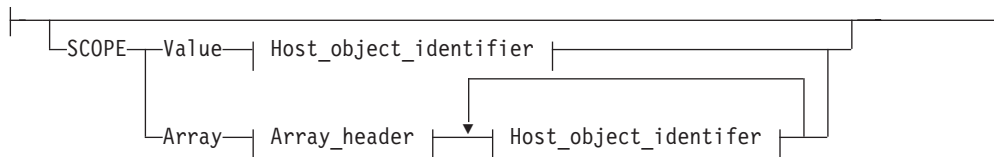

Host_object_identifier:

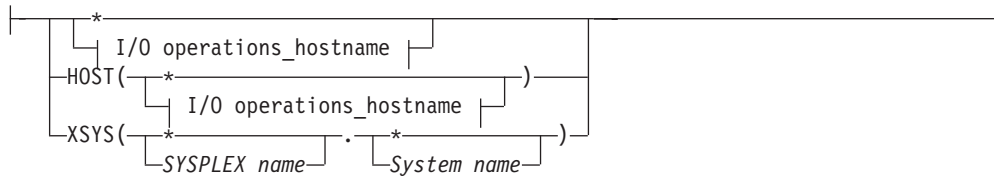

I/O operations_hostname:

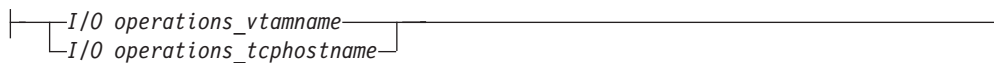

Options:

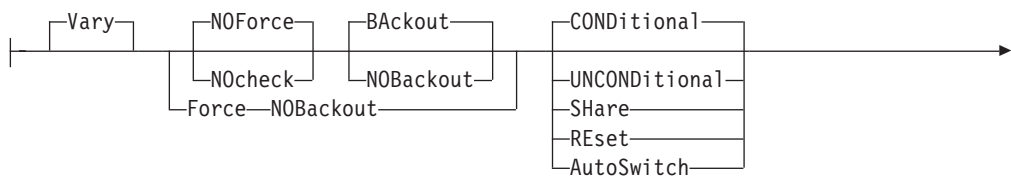



Parameters

A host identifier type can be one of the following keywords:

Vary

This is the default option and it indicates that appropriate processing must be done at the host to support the REMOVE and RESTORE DEVICE commands.

Note: This does not mean that the paths to this device are varied.

NOVary

This option is not valid for the REMOVE and RESTORE DEVICE commands.

Force

This option says to execute the command in the best manner possible. For example, if one of the specified hosts does not respond, the command is still performed on all other hosts.

NOForce

This is the default option and indicates that if there is any failure, the command should not continue and a return and reason describing the failure will be returned.

NOCheck

The NOCheck option overrides the detection of two conditions that would cause the failure of the command under the default NOForce option:

1. Detection of systems in the scope of the command that I/O operations is not operating on
2. Detection of downlevel ESCON Managers operating on systems in the scope of the command

If either of these conditions is detected, a return code of 4 is returned.

BACKout

This is the default option and indicates that if any failure is reported by any of the participating systems, any successful REMOVE and RESTORE DEVICE actions for all the participating host systems will be backed out.

NOBackout

This option indicates that if any error condition is detected during the REMOVE and RESTORE DEVICE processing, I/O operations will not attempt to change any REMOVE and RESTORE DEVICE actions that have been performed.

CONDitional

This is the default option for both the REMOVE and RESTORE DEVICE commands. It indicates that no special Vary offline or Vary online action should be performed.

UNCONDitional

For the REMOVE DEVICE command, this option puts the specified devices immediately into pending offline status, even if the devices are currently active, allocated, or reserved.

REMOVE DEV and RESTORE DEV

For the RESTORE DEVICE command, this option brings the specified devices online, even if there are no paths to the devices, or if the devices are pending offline and boxed. This option is ignored if it is specified for a tape or a direct access device.

SHaRe

For the REMOVE DEVICE command, this option provides no function.

For the RESTORE DEVICE command, this option permits any device that supports multisystem assign to be shared among other processors. If the device does not support multisystem assign, this option is ignored.

REset

For the REMOVE DEVICE command, this option provides no function.

For the RESTORE DEVICE command, this option allows the device to be varied online even if it is currently in use by control unit initiated reconfiguration.

AutoSwitch

The AutoSwitch option is valid only for a tape device such as an IBM 3480 or 3490 (or equivalent). You use Restore Dev AutoSwitch to set the option on and Remove Dev AutoSwitch to set the option off.

Setting AutoSwitch on allows a tape device to be switched serially from one system to another in a sysplex environment without the need for operator intervention.

Note: A coupling facility is required for sysplex tape sharing to be available.

OUTputALL

This is the default and it allows all results from REMOVE and RESTORE DEVICE actions that have been performed (regardless of return code) to be returned to the API invoker.

OUTputERRor

This option allows only error results (that is, REMOVE and RESTORE DEVICE actions with a return code ≥ 4 , plus other errors that occurred during the processing of the command) to be returned to the API invoker.

OUTputNOne

This option allows only the return and reason code (no text information) to be returned to the API invoker. If the return code from the command is ≥ 4 , a detailed message (IHVC00I, IHVC001I, or IHVC002I) is also returned.

Notes:

1. When ARRAY is the *Object_format_type*, the *Object_Identifier_Types* can be mixed and every *Object_Identifier_Type* must be an I/O resource type. For example, an HNUM and an XNUM entry can be in the same array.
2. The Array_header contains the number of elements in the array.
3. PTOK is valid with RANGE but you should be fully aware of PTOK structure. For example, RANGE PTOK could be used to specify all of the serial numbers of a certain type of device. However, certain PTOK values may cause unpredictable results with RANGE
4. When ARRAY is the *SCOPE_format_type*, the *Host_Object_Identifier_Types* can be mixed (HOST and XSYS).

Output

The format of the output from the REMOVE DEV and RESTORE DEV command is as follows:

Table 20. REMOVE DEV and RESTORE DEV Output

Offset					
Dec	Hex	Type	Len	Name(Dim)	Description
0	(0)	STRUCTURE	*	VDCB	
0	(0)	CHARACTER	80	VDCB_HDR	VDCB header
0	(0)	CHARACTER	4	VDCH_ID	Eyecatcher ('VDCB')
4	(4)	UNSIGNED	2	VDCH_HLEN	Header length
6	(6)	UNSIGNED	2	VDCH_RLEN	Row length
8	(8)	UNSIGNED	4	VDCH_NR	Number of rows
12	(C)	UNSIGNED	4	VDCH_NHR	Number of host summary rows
16	(10)	UNSIGNED	1	VDCH_FMTID	Format ID
17	(11)	CHARACTER	7	*	Reserved
Information on the command and options					
24	(18)	BITSTRING	2	VDCH_CMD	Vary device command flags
		1... ..		VDCH_VOFF	1 = Vary OFF device
		.1.. ..		VDCH_VON	1 = Vary ON device
		..1.		VDCH_VBKOUT	1 = Vary backout initiated
		...1 1111 >>		*	Reserved
26	(1A)	BITSTRING	2	VDCH_OPTIONS	Vary device options flags
		1... ..		VDCH_FORCE	1 = Force specified
		.1.. ..		VDCH_NOFORCE	1 = NOForce specified
		..1.		VDCH_BKOUT	1 = BAckout specified
		...1		VDCH_NOBKOUT	1 = NOBackout specified
	 1...		VDCH_NOCHECK	1 = Nocheck specified
	1..		VDCH_COND	1 = CONDitional specified
	1.		VDCH_UNCOND	1 = UNConditonal specified
	1		VDCH_SHARE	1 = SHare specified
27	(1B)	1... ..		VDCH_RESET	1 = REset specified
		.1..		VDCH_AUTOSW	1 = AutoSwitch specified
		..11 1111		*	Reserved
28	(1C)	CHARACTER	4	*	Reserved
Invoker's system and user ID					
32	(20)	CHARACTER	16	VDCH_USER	
32	(20)	CHARACTER	8	VDCH_SYSID	System ID
40	(28)	CHARACTER	8	VDCH_USRID	User ID
Information on primary responding host					
48	(30)	CHARACTER	8	VDCH_APPL	I/O operations VTAM application name
56	(38)	CHARACTER	16	VDCH_SYSPLEX	
56	(38)	CHARACTER	8	VDCH_SPLX	Sysplex name
64	(40)	CHARACTER	8	VDCH_SYST	System name
72	(48)	CHARACTER	4	VDCH_ESCMREL	SA z/OS release
76	(4C)	CHARACTER	4	*	Reserved
Vary device information					
80	(50)	STRUCTURE	296	VDCB_ROW(*)	
80	(50)	UNSIGNED	2	VDCR_FORMAT	Row format code
82	(52)	CHARACTER	6	*	Reserved
Responding host					
88	(58)	CHARACTER	8	VDCR_APPL	I/O operations VTAM application name
96	(60)	CHARACTER	16	VDCR_SYSPLEX	

REMOVE DEV and RESTORE DEV

Table 20. REMOVE DEV and RESTORE DEV Output (continued)

Offset					
Dec	Hex	Type	Len	Name(Dim)	Description
96	(60)	CHARACTER	8	VDCR_SPLX	Sysplex name
104	(68)	CHARACTER	8	VDCR_SYST	System name
Device identification					
112	(70)	BITSTRING	2	VDCR_FLAGS	Vary device flags
		1... ..		VDCR_RNUMV	1=RNUM is valid
		.111 1111		*	Reserved
113	(71)	1... ..		VDCR_COUPL	1 = Device is a coupling facility
		.1.. ..		VDCR_NOVARY	1 = Don't vary device for row
		..1.		VDCR_NOTFND	1 = Device not found for host
		...1		VDCR_BKOUT	1 = Backout attempted, msg present
	 1111		*	Reserved
114	(72)	UNSIGNED	2	VDCR_DEVNUM	Device number
116	(74)	BITSTRING	4	VDCR_SCPSTS	Operating system state
120	(78)	CHARACTER	32	VDCR_PTOKN	Physical token
152	(98)	CHARACTER	32	VDCR_LTOKN	Logical token
Vary results					
184	(B8)	CHARACTER	96	VDCR_VRESULTS	
184	(B8)	BITSTRING	2	VDCR_VFLAGS	Vary flags
		1... ..		VDCR_VMVS_MSG	1 = Vary message is MVS
		.1.. ..		VDCR_VDBCS	1 = Vary message is DBCS
		..11 1111 >>		*	Reserved
186	(BA)	CHARACTER	2	*	Reserved
188	(BC)	UNSIGNED	4	VDCR_VESCMRC	I/O operations Severity code (used for backout, msg screen)
The following information is valid only when VDCR_NOVARY is not set					
192	(C0)	UNSIGNED	4	VDCR_VMVSRC	Return code from VARYDEV macro
196	(C4)	UNSIGNED	4	VDCR_VMVSRN	Reason Code from VARYDEV macro
200	(C8)	CHARACTER	80	VDCR_VMVSMMSG	Msg from VARYDEV macro or I/O operations based on macro RC/RSN
Backout results					
280	(118)	CHARACTER	96	VDCR_BRESULTS	
280	(118)	BITSTRING	2	VDCR_BFLAGS	Backout flags
		1... ..		VDCR_BMVS_MSG	1 = Backout message is MVS
		.1.. ..		VDCR_BDBCS	1 = Backout message is DBCS
		..11 1111 >>		*	Reserved
282	(11A)	CHARACTER	2	*	Reserved
284	(11C)	UNSIGNED	4	VDCR_BESCMRC	I/O operations Severity code
The following information is valid only when I/O operations backout occurs (VDCH_BKOUT=1) and there are no communication errors reported					
288	(120)	UNSIGNED	4	VDCR_BMVSRC	Return code from VARYDEV macro
292	(124)	UNSIGNED	4	VDCR_BMVSRN	Reason code from VARYDEV macro
296	(128)	CHARACTER	80	VDCR_BMVSMMSG	Msg from VARYDEV macro or I/O operations based on macro RC/RSN

WRITEFILE

Purpose

Use the WRITEFILE command at the I/O operations API to store a saved switch configuration at the switch specified in the command.

To use the WRITEFILE command, the switch must be allocated, or attached, to the issuing I/O operations.

Syntax

►►—WRITEFILE—*filename—filedescriptor—datablock*—◄◄

Parameters

filename

Specify the file name in 1 through 8 valid EBCDIC codes. Valid codes are uppercase alphabetical characters (A-Z), digital characters (0-9), and 2 special characters: the underscore (_) and the hyphen (-). However, the following file names are not valid: AUX, COM*n* (where *n*=1-4), CON, LPT*n* (where *n*=1-3), NUL, or PRN.

filedescriptor

Specify the file descriptor in exactly 24 characters in the range X'40' through X'FE'.

datablock

Specify a 20480-byte data block in the format listed under the Query Switch command. The data block allows an 80-byte record for 256 ports. Specify the ports in ascending hexadecimal order.

Usage

- A maximum number of saved switch configurations can be stored at a switch. At an IBM Director, you can store up to 15 saved configurations. In addition, you can load and restore the IPL file, which is supplied with each Director and is activated automatically when the unit is powered on.
- You can only write the IPL file if the Active=Save Mode at the switch is disabled. If the mode is disabled, any changes being made to the active configuration at the switch are not saved. The mode setting is displayed on the screen of the switch console. The status is also returned in the QFILAS field in the output returned with the Q F * command.
- You must specify the switch device number in the data block., (Unlike the WRITESWCH command, the switch device number in the Writefile command must be the same in each record.)
- If you do not want to write an entire block, you can edit an existing one. For example, you can use the Query File command to get a file, edit it, and then use the WRITEFILE command to store it.

Input

Each 80-byte record of the WRITEFILE data block has the following format:

WRITEFILE

Table 21. WRITEFILE Input Format

Offset					
Dec	Hex	Type	Len	Name(Dim)	Description
0	(0)	STRUCTURE	80	WTFL	Writefile record
0	(0)	BITSTRING	1	WTFLFLAG1	End of list indicator 0 = More records in list 1 = Last record in list
		1... ..		WTFLLAST	
		.1.. ..	*		Reserved
		..11		WTFLFORM	Format ID 00 = Format 0 (original format)
	 1111	*		Reserved
1	(1)	CHARACTER	1	*	Reserved
2	(2)	UNSIGNED	2	WTFLSWIT	Switch device number
4	(4)	CHARACTER	48	WTFLLAIB	Switch port information block
4	(4)	CHARACTER	2	*	Reserved
6	(6)	UNSIGNED	1	LAIBADDR	Port address
7	(7)	CHARACTER	1	*	Reserved
8	(8)	BITSTRING	4	LAIBDESC	Port descriptors
		1... ..		LAIBUNMP	Port implementation 0 = Implemented port 1 = Unimplemented port
		.1.. ..		LAIBFBIT	Blocked port 0 = Port is not blocked 1 = Port is blocked
		..1.		LAIBIC	Prohibited port connection 0 = No prohibits for this port 1 = Prohibits defined
		...1		LAIBSBIT	Port connection 0 = Port is not connected 1 = Port is connected
	 1111 >>	*		Reserved
12	(C)	CHARACTER	2	*	Reserved
14	(E)	UNSIGNED	1	LAIBSADR	Static connection address
15	(F)	CHARACTER	5	*	Reserved
20	(14)	BITSTRING	32	LAIBICM	Link ICM
52	(34)	CHARACTER	24	WTFLNAME	Port logical name
76	(4C)	CHARACTER	4	*	Reserved

WRITEPORT

Purpose

Use the Writeport command at the I/O operations API to define or to change the connectivity attributes for a single port on a specified switch.

Syntax

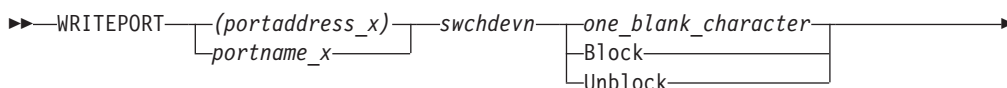

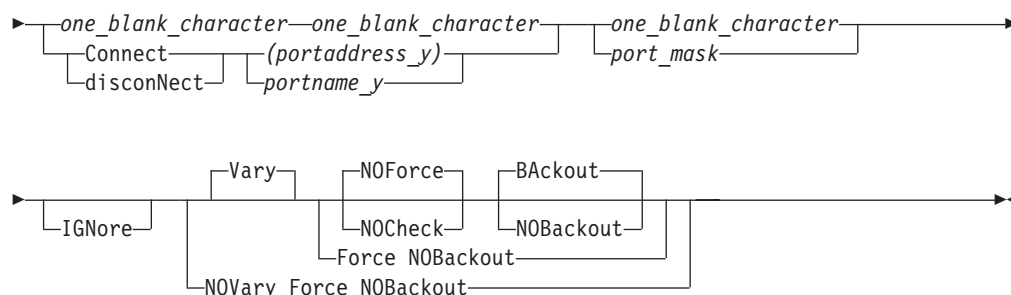

Parameters

(portaddress_x) | portname_x

Specifies the target port by its port address (enclosed in parentheses) or by its port name.

swchdevn | *

Specifies the target switch device number. The switch must be allocated to, or attached to, the issuing I/O operations.

one_blank_character | Block | Unblock

Specifies one of the following: the blocking attribute should be unchanged (X'40'); the port should be blocked; the port should be unblocked.

one_blank_character | Connect | disconNect

Specifies one of the following: the dynamic connection attribute should be unchanged (X'40'); the port should be statically connected to the port specified in the next operand; the port should be disconnected from that port.

(portaddress_y) | portname_y

Specifies the other port in the static connection by its port address or port name.

one_blank_character | port_mask

A blank character specifies that the allow and prohibit attributes of port_x should be unchanged. The 256-character (32-byte) mask specifies an A (Allow) or a P (Prohibit) as the attribute for each port in the range X'00–FF'. The character representing port_x must and all unimplemented ports must be P, while the character representing the control unit port (CUP) must be A

IGNore

You must specify this option when an Inter-Switch-Link port (E_Port) is involved. Otherwise the command is rejected with return code 8 and reason code X'49'. The reason is I/O operations can no longer guarantee "safe-switching" when an E_Port is involved.

"Safe-switching" sets the paths and devices online or offline when the path from a chpid to a device either becomes valid or is no longer valid because of a port manipulation.

Vary

This is the default option and it indicates that appropriate processing must be done at the host to support the REMOVE and RESTORE CHP commands.

NOVary

This option is not valid for the WRITEPORT command.

WRITEPORT

Force

This option says to do the command in the best manner possible. For example, if one of the specified hosts does not respond, the command is still performed on all other hosts.

NOForce

This is the default option and indicates that if there is any failure, the command should not continue and a return call and reason describing the failure will be returned.

NOCheck

The NOCheck option overrides the detection of two conditions that would cause the failure of the command under the default NOForce option:

1. Detection of systems in the scope of the command that I/O operations is not operating on
2. Detection of downlevel I/O operations's operating on systems in the scope of the command

If either of these conditions is detected, a return code of 4 is returned.

BAckout

This is the default option and indicates that if any failure is reported by any of the participating systems, any successful WRITEPORT actions for all the participating host systems will be backed out.

NOBackout

This option indicates that if any error condition is detected during the WRITEPORT processing, I/O operations will not attempt to change any WRITEPORT actions that have been performed.

Usage

Using the Writeport command is a tool that helps you simplify the installation, set up, and recovery of a switch's configuration. Note, however, that the WRITESWCH command lets you manipulate attributes of all the ports on a switch.

The number and placement of implemented ports depends on the model of the switch. You can display the addressable ports with the commands described under "QUERY SWITCH" on page 223.

Also, see *Planning for the 9032 Enterprise Systems Connection Director* or *Planning for the 9033 Enterprise Systems Connection Director* for CUP information pertinent to the ESCON Directors.

Examples

Here is a segment of an MVS REXX EXEC that contains the command WRITEPORT (C3) 0500 B C (C1)

```
IHVRC = 0                /* Return code; it must be          */
/* called IHVRC.          */
/*                        */
IHVREAS = 0              /* Reason code; it must be          */
/* called IHVREAS.        */
/*                        */
IHVRESP = ' '           /* Response area; it must be        */
/* called IHVRESP.        */
/*                        */
cmd = 'WRITEPORT'       /* Command name (required)          */
opr1 = '(C3)'           /* Port address/port name (required) */
opr2 = '0500'           /* Switch device number (required)   */
opr3 = 'BLOCK'         /* Block/Unblock/blank (required)    */
```

WRITEPORT

```
/* 0123456789ABCDEF0123456789ABCDEF0123456789ABCDEF0123456789ABCDEF */
/* | | | Vertical lines point to prohibited ports | | */
M='AAPAPAPAAAAAAAAAAAAAAAAAAAAAAAAAAAAAAAAAAAAAAAAAAAAAAAAAAAAAAAAAAPPAP'
/*
opr6 = COPIES('P',192) | | M /* Allow/prohibit attributes */
/*
ADDRESS LINK 'IHVAPI' cmd opr1 opr2 opr3 opr4 opr5 opr6
/*****/
```

In Example 1, switch 0500 has 60 available ports (*C0 through FB*). The variable *M* has been used to represent these ports. The first operand (*opr1*) is given the value of *C2*. Port *C2* is set to *P*, as well as ports *C4* and *C6*. This prohibits dynamic connections from port *C2* to port *C4* and from port *C2* to port *C6*. However, connectivity between ports *C4* and *C6* has not been interrupted.

Example 2 shows how to prohibit port *C6* from dynamically connecting with port *C8*, while maintaining the attributes set in Example 1. Port *C2* is set to *P*, as well as ports *C6* and *C8*. This is because each *WRITEPORT* command writes over the attributes of the previous settings. If port *C2* had not been set to *P*, dynamic connectivity between ports *C2* and *C6* would have been allowed. Remember, the original goal was to prohibit port *C2* from connecting with ports *C4* and *C6* and to prohibit port *C6* from connecting with ports *C2* and *C8*.

```
*****/
/* Example 2: Using WRITEPORT to Prohibit C6 from C8 */
*****/
cmd = 'WRITEPORT' /* Command (required) */
opr1 = '(C6)' /* Port/Port name (required) */
opr2 = '0500' /* Switch device number (required) */
opr3 = ' ' /* Block/Unblock/blank (required) */
opr4 = ' ' /* Connect/discoNnect/blank (required) */
opr5 = ' ' /* Port/Port name/blank (required) */
/* Allow/Prohibit string as follows: */

/* CCCCCCCCCCCCCDDDDDDDDDDDDDEEEEEEEEEEEEEEEEEEEEEEEEEEEEEEEEEEEEEEE */
/* 0123456789ABCDEF0123456789ABCDEF0123456789ABCDEF0123456789ABCDEF */
/* | | | Vertical lines point to prohibited ports | | */
M='AAPAAPAPAAAAAAAAAAAAAAAAAAAAAAAAAAAAAAAAAAAAAAAAAAAAAAAAAAAAAAAAAAPPAP'
/*
opr6 = COPIES('P',192) | | M /* Allow/prohibit attributes */
/*
ADDRESS LINK 'IHVAPI' cmd opr1 opr2 opr3 opr4 opr5 opr6
/*****/
```

In the previous examples, discussion was limited to ports *C2*, *C4*, *C6*, and *C8*. Remember, however, that each *WRITEPORT* command defines and possibly changes the connectivity attributes for every implemented port on the specified switch. Therefore, construct the allow or prohibit string with special care.

It is advisable to use the active attribute string as a starting point. Sending the Query Switch command is a convenient way for an application program to obtain the active attribute string.

WRITESWCH

Purpose

Use the WRITESWCH command at the API to make changes (update) up to 512 addressable ports on any number of switches that are allocated to, or attached to, the issuing I/O operations. This command is available only at the API because it requires input in hexadecimal format.

Syntax

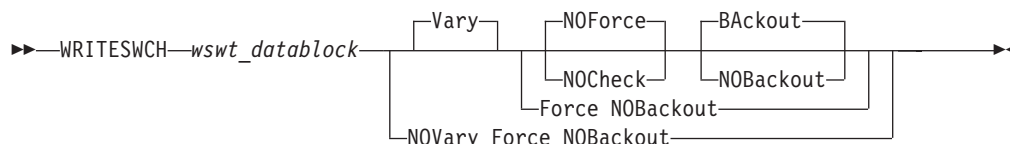

Parameters

Vary

This is the default option and it indicates that appropriate processing must be done at the host to support the WRITESWCH command.

NOVary

This option is not valid for the WRITESWCH command.

Force

This option says to do the command in the best manner possible. For example, if one of the specified hosts does not respond, the command is still performed on all other hosts.

NOForce

This is the default option and indicates that if there is any failure, the command should not continue and a return and reason describing the failure will be returned.

NOCheck

The NOCheck option overrides the detection of two conditions that would cause the failure of the command under the default NOForce option:

1. Detection of systems in the scope of the command that I/O operations is not operating on
2. Detection of downlevel I/O operations's operating on systems in the scope of the command

If either of these conditions is detected, a return code of 4 is returned.

BAckout

This is the default option and indicates that if any failure is reported by any of the participating systems, any successful WRITESWCH actions for all the participating host systems will be backed out.

NOBackout

This option indicates that if any error condition is detected during the WRITESWCH processing, I/O operations will not attempt to change any WRITESWCH actions that have been performed.

WRITESWCH

Input

The format of the *WSWT_datablock* is an array of 1 or more entries of the following structure:

Table 22. WRITESWCH Input

Offset					
Dec	Hex	Type	Len	Name(Dim)	Description
0	(0)	STRUCTURE	80	WSWT	
0	(0)	BITSTRING	1	WSWTFLAG1	Flags byte 1
		1... ..		WSWTLAST	End of list indicator 0 = More records 1 = Last record in array
		.1.. ..		WSWTMDPT	Midport 1 = This port is the midport of a defined chain
		..11 ..		WSWTFORM	Format ID 0 = Format 0 (original format)
	 1..		WSWTMBSR	Modify block state request 0 = No change to block state 1 = Change block state
	1..		WSWTMCSR	Modify connect state request 0 = No change to connect state 1 = Change connect state
	1.		WSWTLNVB	Logical name validity 0 = Ignore logical name information 1 = Write logical name to port address
	1		WSWTCIVB	Chain information validity 0 = Ignore chain information 1 = Set up chain
1	(1)	BITSTRING	1	WSWTFLAG2	Flags byte 2
		1... ..		WSWTMMR	Modify mask request 0 = No change to current PDCM 1 = Change current PDCM
		.1.. ..		WSWTAMR	AND mask request 0 = No change to current PDCM 1 = AND given mask with current PDCM
		..1.		WSWTOMR	OR mask request 0 = No change to current PDCM 1 = OR given mask with current PDCM
		...1 1111		*	Reserved
2	(2)	UNSIGNED	2	WSWTSWIT	Switch device number
4	(4)	CHARACTER	48	WSWTLAIB	Port information block
4	(4)	CHARACTER	1	*	Reserved
5	(5)	UNSIGNED	1	LAIBNUMB	Port number
6	(6)	UNSIGNED	1	LAIBADDR	Port address
7	(7)	CHARACTER	1	*	Reserved
8	(8)	BITSTRING	4	LAIBDESC	Port descriptors
		1... ..		LAIBUNMP	Port implementation 0 = Port is implemented 1 = Port is not implemented
		.1..		LAIBFBIT	Port fence information 0 = Port is not blocked 1 = Port is blocked

Table 22. WRITESWCH Input (continued)

Offset							
Dec	Hex	Type	Len	Name(Dim)	Description		
		..1.		*	Reserved		
		...1		LAIBSBIT	Port connection	0 = Port is not connected	1 = Port is connected
	 1111 >>		*	Reserved		
12	(C)	CHARACTER	2	*	Reserved		
14	(E)	UNSIGNED	1	LAIBSADR	Static connection port address		
15	(F)	CHARACTER	5	*	Reserved		
20	(14)	BITSTRING	32	LAIBICM	Port prohibit dynamic connection mask (PDCM)		
52	(34)	CHARACTER	24	WSWTNAME	Port logical name		
76	(4C)	UNSIGNED	2	WSWTCSWIT	Switch device number for chained switch		
78	(4E)	UNSIGNED	1	WSWTCPORT	Chained port address		
79	(4F)	CHARACTER	1	*	Reserved		

How to Set Up the Data Block

By using the described data block, an API user can change the connectivity attributes of a port. The changes that are requested are controlled by Request bits in the beginning of the block that must be used in order to say what type of action is requested. If no request bits are set then the given block is skipped and treated as a no-op.

Listed below are the commands that can be processed with 1 WSWT block. The bits that must be set are also listed as well as the data required to make the change.

As stated earlier, you can make more than one change on a port block by setting the appropriate combination of bits. For example, you can effectively enter a Block and a Connect command at the same time by making sure that all the bits that are relevant for both commands are set on the same block.

Block

WSWTMBSR

Must be set to 1 to indicate that the block state should be changed.

LAIBFBIT

Must be set to 1 to indicate that the port should be blocked.

LAIBADDR

Contains the port address.

WSWTSWIT

Contains the switch that the port address is on.

WSWTFORM

Must be set to 00.

Unblock

WSWTMBSR

Must be set to 1 to indicate that the block state should be changed.

WRITESWCH

LAIBFBIT

Must be set to 0 to indicate that the port should be unblocked.

LAIBADDR

Contains the port address.

WSWTSWIT

Contains the switch that the port address is on.

WSWTFORM

Must be set to 00.

Connect

WSWTMCSR

Must be set to 1 to indicate that the connection state should be changed.

LAIBSBIT

Must be set to 1 to indicate that the port should be connected.

LAIBADDR

Contains the port address.

LAIBSADR

Contains the port address that LAIBADDR should be connected to.

WSWTSWIT

Contains the switch that the port addresses are on.

WSWTFORM

Must be set to 00.

Disconnect

WSWTMCSR

Must be set to 1 to indicate that the connection state should be changed.

LAIBSBIT

Must be set to 0 to indicate that the port should be disconnected.

LAIBADDR

Contains the port address.

LAIBSADR

Contains the port address that LAIBADDR should be disconnected from.

WSWTSWIT

Contains the switch that the port addresses are on.

WSWTFORM

Must be set to 00.

Chain

WSWTCIVB

Must be set to 1 to indicate that the chain information is valid and you want to change it.

WSWTMDPT

Must be set to 1 to indicate that this port is the midport on the chain.

WSWTMCSR

Must be set to 1 to indicate that the connection state should be changed.

LAIBSBIT

Must be set to 1 to indicate that the port should be chained by setting a connection between LAIBADDR and LAIBSADR.

LAIBADDR

Contains the port address.

LAIBSADR

Contains the port address that LAIBADDR should be connected to.

WSWTSWIT

Contains the switch that the port addresses are on.

WSWTCPORT

Contains the chained port address that LAIBADDR should be chained to.

WSWTCSWIT

Contains the switch that the chained port address is on.

WSWTFORM

Must be set to 00.

Unchain**WSWTCIVB**

Must be set to 1 to indicate that the chain information is valid and you want to change it.

WSWTMDPT

Must be set to 1 to indicate that this port is the midport on the chain.

WSWTMCSR

Must be set to 1 to indicate that the connection state should be changed.

LAIBSBIT

Must be set to 0 to indicate that the port should be unchained by disconnecting LAIBADDR and LAIBSADR.

LAIBADDR

Contains the port address.

LAIBSADR

Contains the port address that LAIBADDR should be disconnected from.

WSWTSWIT

Contains the switch that the port addresses are on.

WSWTCPORT

Contains the chained port address that LAIBADDR should be unchained from.

WSWTCSWIT

Contains the switch that the chained port address is on.

WSWTFORM

Must be set to 00.

Write**WSWTLNVB**

Must be set to 1 to indicate that the logical name field is valid.

LAIBADDR

Contains the port address.

WSWTNAME

Contains the logical name that should be assigned to the port address given in LAIBADDR.

WRITESWCH

WSWTSWIT

Contains the switch that the port addresses are on.

WSWTFORM

Must be set to 00.

Modify PDCM

WSWTMMR

Must be set to 1 to indicate that the PDCM should be modified.

LAIBADDR

Contains the port address.

LAIBICM

Contains the new PDCM for the given port.

WSWTSWIT

Contains the switch that the port addresses are on.

WSWTFORM

Must be set to 00.

And PDCM

WSWTAMR

Must be set to 1 to indicate that the given PDCM should be AND'ed with the current PDCM.

LAIBADDR

Contains the port address.

LAIBICM

Contains the PDCM to be AND'ed for the given port.

WSWTSWIT

Contains the switch that the port addresses are on.

WSWTFORM

Must be set to 00.

Or PDCM**WSWTOMR**

Must be set to 1 to indicate that the given PDCM should be OR'ed with the current PDCM.

LAIBADDR

Contains the port address.

LAIBICM

Contains the PDCM to be OR'ed for the given port.

WSWTSWIT

Contains the switch that the port addresses are on.

WSWTFORM

Must be set to 00.

Usage

- The WSWT data block that you enter is a series of 80-byte WSWT structures that I/O operations processes sequentially. Be sure to take this into account. For example, assume ports *FB* and *EA* are statically connected, and you want ports *CO* and *EA* to be statically connected instead.

Note: If the WSWT structure contains an "AND PDCM" or an "OR PDCM" bit setting, there may only be one "AND PDCM"/ "OR PDCM" and no "MODIFY PDCM", in the structure.

1. In the data block, disconnect *FB* and *EA* first.
2. Then, connect *CO*, and *EA*.

If you reverse the order, the command will fail because *EA* is already statically connected.

- If you specify Vary, I/O operations varies the relevant paths in all the WSWT structures offline first. If these operations are all successful or if you specified Force, the program then sends all the WSWT structures to the affected switch(es). If these operations are successful, I/O operations then varies the appropriate paths online.
- The Writeswch command is used implicitly when you activate a switch configuration in matrix format by using either the I/O operations ISPF dialog or the workstation feature.

WRITESWCH

Chapter 8. Invoking I/O Operations with a REXX EXEC

Rules for Calls by a REXX EXEC

Separate the parameters as follows:

- If the REXX EXEC uses the address link invocation to call the API, the parameters must be separated by blanks as shown:
`address link 'IHVAPI' parm1 ... parmn`
- If the REXX EXEC uses the REXX call to call the API, the parameters must be separated by commas as shown:
`call 'IHVAPI' parm1,parm2,parm3,...`

Specify the following variables:

ihvrc

To receive the return code

ihvreas

To receive a reason code

ihvresp

As the response area to receive the command output if there is any

When specifying the variables listed above, note the following:

- The return code is in printable *decimal* format, while the reason code is in printable *hexadecimal* format. See *SA OS/390 Messages and Codes* for a list of reason codes.
- A return code and reason code are not provided if more parameters were specified in the input parameter list than are allowed for a REXX EXEC. A REXX error message is sent instead.
- If `ihvrc` and `ihvreas` are not specified, I/O operations can still process the command. However, the EXEC might not be able to check whether the command was processed successfully because no return code or reason code can be checked.
- If `ihvresp` is not specified, I/O operations can process the command but cannot return data to the REXX EXEC.

Literal Values

If the REXX EXEC calls I/O operations using literal values, the literal value for each parameter should be enclosed in single quotes (') to avoid ambiguity during processing.

Optional Variables

Optionally, a REXX EXEC caller can:

- Set a variable equal to the name of the command being specified
- Set a variable for each operand and option associated with the command being specified.

Two Examples of REXX EXEC Calls

Example of a Call to Connect Two Ports

In the following example, the caller enters the CONNECT command to connect port C0 statically, or *dedicate* it, to port E0 on switch 100.

```
/* Connect EXEC */
ihvrc = 0                                /* Return code must be called */
/*                                         */
ihvreas = 0                              /* Reason code must be called */
/* ihvreas. Name must be in EXEC. */
/*                                         */
ihvresp = ' '                            /* Response area must be called */
/* ihvresp. Name must be in EXEC. */
/*                                         */
parm1 = 'CONNECT'                        /* Command name */
parm2 = '(C0)'                           /* First port address (operand) */
parm3 = '(E0)'                           /* Second port address (operand) */
parm4 = '0100'                           /* Switch device number (operand) */
parm5 = 'NOFORCE'                        /* These are the default options */
parm5 = 'VARY'                            /* that do not have to be */
parm7 = 'BACKOUT'                        /* specified in the EXEC. */
```

If the Caller Uses the Address Link Invocation:

```
address link 'IHVAPI' parm1 parm2 parm3 parm4 parm5 parm6 parm7
say "RETURN CODE = " ihvrc
say "REASON CODE = " ihvreas
say "RESPONSE AREA = " ihvresp
/* Assume screen is 80 characters - */
/* Will appear to be printing 80-character records */

EXIT
```

If the Caller Uses the REXX Call:

```
call 'IHVAPI' parm1,parm2,parm3,parm4,parm5,parm6,parm7
say "RETURN CODE = " ihvrc
say "REASON CODE = " ihvreas
say "RESPONSE AREA = " ihvresp
/* Assume screen is 80 characters - */
/* Will appear to be printing 80-character records */

EXIT
```

Generalized Example of a REXX EXEC Call

When processed, the following REXX EXEC can be used to enter any I/O operations command. The 80-character output is assumed to be in message format, so QUERY output will not be readable.

```
/*                                         */
/* Initialization */
/*                                         */
linelength = 80                          /* length of 1 response line */
/*                                         */
/* Get the command as specified by the user */
/*                                         */
Parse Upper Arg IHVX1 IHVX2 IHVXPARMS
/*                                         */
/* Correct basic syntax errors for the user */
/*                                         */
/* - Capitalize command keywords (must be caps for IHV) */
/* - Strip out extraneous blanks (must have only 1 for IHV) */
/*                                         */
IHVXCMD = Space(IHVX1 IHVX2 IHVXPARMS,1)
Drop IHVX1 IHVX2 IHVXPARMS
/*                                         */
```

```

/* Tell the user what we are about to do          */
/*                                              */
Say 'Issuing the IHV command:' IHVXCMD          */
/*                                              */
/* Issue the command                            */
/*                                              */
Address LINK 'IHVAPI' IHVXCMD                  */
If IHVRC > 4                                     */
Then                                           /* Command failed */
Do;
    Say 'Return code:' IHVRC 'Reason code:' IHVREAS
End;
/*                                              */
/* Show the user the response from the command */
/*                                              */
Do lineindex = 1 to Length(IHVRESP) by lineLength;
    Say Substr(IHVRESP,lineindex,lineLength);
End;
/*                                              */
/* Return to the caller                          */
/*                                              */
Exit IHVRC;

```

Calling a Program that Uses the CALL Macro

General Information

I/O operations allows a program that uses the CALL macro to invoke either IHVAPI2 or IHVAPI.

The Parameter Lists

The caller must pass a variable-length parameter list, where:

- Each item in the list is an address of a parameter in the calling program. (The language that the program is written in must allow the program to alter the parameters for return code, reason code, and response area.)
- The high-order bit of the last parameter address must be set to 1 to indicate the end of the list.
- Register 0 must be set to 0 (zero) so that I/O operations knows the invocation is from an assembled user program, and not an interpreted REXX EXEC.
- Register 1 must contain the address of the parameter list.

The Caller Should Check Register 15 Upon Return From the Call

If not enough parameters were passed on the CALL, I/O operations returns a reason code of X'D0xx0001' in register 15. This code specifies that either an empty or an incorrect parameter list has been sent.

- If IHVAPI2 was invoked, at least 5 parameters are needed: the command name and the last four variables listed in 252.
- If IHVAPI was invoked, at least 4 parameters are needed: the command name and the variables listed in 252.

If more than 25 parameters were passed on the CALL, I/O operations returns a reason code of X'D0xx0007' in register 15. This code specifies that the list contained too many parameters.

For a comparison between IHVAPI2 and IHVAPI, refer to “Calling the I/O Operations API” on page 173.

Calling a Program that Uses IHVAPI2

Pass the Following Parameters in the Parameter List:

- One 38-character variable (padded on the right with blanks) equal to the name of the I/O operations command being specified.
- As many 38-character variables (each padded on the right with blanks) as needed for the operands in the command with the following exceptions:
 - For a range, specify a 71-character variable.
 - For an array, data block, or table, specify a variable long enough to contain it.
- As many 38-character variables (each padded on the right with blanks) as needed for the options associated with the command.
- As the fourth-from-last and the third-from-last variables, specify information related to the response area. Because these two parameters are interdependent, they are listed in the table following this list.
- As the second-from-last (or next-to-last) variable, specify a 4-byte field in hexadecimal format for the return code.
- As the last variable, specify a 4-byte field in hexadecimal format for the reason code.

4th-From-Last Parameter	3rd-From-Last Parameter	When the Response Area Is To Be Managed By:
0 (zero)	any value	I/O operations with a new output buffer
Response area address	0 (zero)	I/O operations with a re-used output buffer
Response area address	Response area length	Caller

Notes:

1. Initialize the response area.
2. If I/O operations manages the response area, the caller must not modify any of the fields in the prefix area, which is described in "A Prefix Area Can Precede the Response Area." If a field is modified, the results are unpredictable.
3. On return from the call, I/O operations puts the length of the response area that it used in the third-from-last parameter. It returns a length of 0 (zero) if no response data is returned. Therefore, the caller should save the input value of this parameter before invoking I/O operations.
4. If the caller manages the response area, the caller should update the third-from-last parameter for each invocation.

To Invoke IHVAPI2, Specify the Following:

CALL IHVAPI2,addrPARM1, ... addrPARMn

A Prefix Area Can Precede the Response Area

If I/O operations manages the response area, it returns a prefix area as well. Use the following information when you need to release these areas.

- x Is the address of the response area, which is contained in the fourth-from-last parameter.

x-4

Is the 4-byte address of the prefix area, which immediately precedes the response area.

x-12

Bytes is the 1-byte 'subpool number '0'.

x-16

Bytes is the 4-byte length of the prefix area plus the contiguous response area.

For further information, refer to "General Information About the Response Area" on page 174 and to the following example.

Example of a Caller Invoking IHVAPI2

```
ESCMSAMP CSECT
*****
* Issue multisystem QUERY INTERFACE Switch to get switch port
* information. R1 points to a 4 character switch device number.
*****
MVC SWITCH_DEVICE(4),0(R1) Get Switch device number
MVC HNUM+14(4),0(R1) Set number in query command
SR R0,R0 Required by I/O Operations
CALL IHVAPI2,(QUERY,INTERFACE,SWITCH,HNUM,VALUE, X
          ASTERISK,SCOPE,VALUE,ASTERISK, X
          QIS@,QISLENGTH,RC,REASON),VL
CLC RC,=F'0' 0 means all hosts responded ok
BNE FREE If not, then free storage
*****
* Map the QUERY INTERFACE Switch row data.
*****
QISOK L R10,QIS@ Point to I/O Operations output area
USING QISINFO,R10 Map query interface info
LH R9,HDRSIZE Get the QIS header size
AR R9,R10 Point to the first port row
USING PORTROW,R9 Map port interface row
:
*****
* A port that needs blocking is found, so block it.
*****
UNPK PORTNUMBER+1(3),PORTNUM(2) Convert 1 byte hex port
TR PORTNUMBER+1(2),TRANTAB-C'0' number to EBCDIC
MVI PORTNUMBER+3,C')' Restore trailing ")"
MVC BLKLENGTH,=F'0' Let manage the buffer
SR R0,R0 Required by I/O Operations
CALL IHVAPI2,(BLOCK,PORTNUMBER,SWITCH_DEVICE, X
          BLOCK@,BLKLENGTH,RC,REASON),VL
CLC RC,=F'4' Block worked?
BNE NOBLOCK No, then process error
:
*****
* Now done with ESCM obtained storage, so release it.
*****
DROP R10
FREE L R10,QIS@ Get Query output buffer
C R10,=F'0' I/O Operations Query buffer exists?
BE CONTINUE No, continue
S R10,=F'16' Address I/O Operations Query buffer
USING ESCMPREFIX,R10
L R2,BUFLLENGTH Get buffer length
L R3,BUFSUBPOOL Get buffer subpool
STORAGE RELEASE,LENGTH=(R2),ADDR=BUF@,SP=(R3)
L R10,BLOCK@ Get Block output buffer
C R10,=F'0' I/O Operations Block buffer exists?
BE CONTINUE No, continue
S R10,=F'16' Address I/O Operations Query buffer
L R2,BUFLLENGTH Get buffer length
L R3,BUFSUBPOOL Get buffer subpool
STORAGE RELEASE,LENGTH=(R2),ADDR=BUF@,SP=(R3)
:
```

```

*****
* I/O Operations API parameters
*****
QIS@      DC      A(0)
QISLENGTH DC      F'0'
BLOCK@    DC      A(0)
BLKLENGTH DC      F'0'
RC        DC      F'0'
REASON    DC      F'0'
QUERY     DC      CL38'QUERY'
INTERFACE DC      CL38'INTERFACE'
SWITCH    DC      CL38'SWITCH'
VALUE     DC      CL38'VALUE'
ASTERISK  DC      CL38'*'
SCOPE     DC      CL38'SCOPE'
BLOCK     DC      CL38'BLOCK'
HNUM      DC      CL38'HNUM(THIS-SYS.XXXX)'
PORTNUMBER DC     C'(',CL2' ',C')',CL34' '
SWITCH_DEVICE DC  CL38' '
*
TRANTAB   DC      CL16'0123456789ABCDEF'
*
QISINFO   DSECT                                QUERY INTERFACE Switch output
DS      CL4
HDRSIZE   DS      H                            Size of this header
ROWSIZE   DS      H                            Size of each row
DS      CL44
NUMROWS   DS      F                            Number of rows
*
PORTROW   DSECT
PORTNUM   DS      XL1                           Port number
DS      CL155
ROWCODE   DS      F                            Query row code (see below)
PORTROW   EQU     0                            Port row with no error
SUMMROW   EQU     X'5100FFFF'                  Summary row
*
ESCOMPREFIX DSECT                                I/O Operations supplied buffer info
BUFLNGTH   DS      F                            Buffer length
BUFSUBPOOL DS      FL1                          Subpool number
DS      F
BUF@       DS      A                            Buffer address
:

```

Calling a Program that Uses IHVAPI

Pass the Following Parameters in the Parameter List:

- A 24-character variable (padded on the right with blanks) equal to the name of the I/O operations command being specified.
- A 24-character variable (padded on the right with blanks) for each operand in the command—with the exception of an operand that contains an array, data block, or table. In these cases, specify a variable that is long enough to contain the item. (Note, however, that I/O operations only uses 64KB of the response area on an IHVAPI call.)
- A 24-character variable (padded on the right with blanks) for each option in the command.
- As the third-from-last variable, specify the address of the response area. (Initialize the response area.)

When a caller invokes IHVAPI, I/O operations can return up to 64KB of data in the response area. If the command output exceeds this amount, I/O Operations fills the response area and notifies the caller that an overflow condition has occurred. Assume, however, that an area of 24KB is sufficient for most

commands. Exceptions can be such commands as the DISPLAY DEVICE, DISPLAY RESULTS, DISPLAY VARY, QUERIES, REMOVE DEV, and RESTORE DEV commands.

- As the second-from-last variable, specify a 4-byte field in hexadecimal format for the return code.
- As the last variable, specify a 4-byte field in hexadecimal format for the reason code.

To Call IHVAPI, Specify the Following:

```
CALL IHVAPI,(CMD,PARM1,...PARMn,IHVRESP,IHVRC,IHVREAS),VL
```

Part 4. Status Display Facility Definitions

Chapter 9. SDF Initialization Parameters	259	AOFTREE	273
DCOLOR	259	PANEL	276
DPFKnn	260	STATUSFIELD	277
DPFKDESC1	261	STATUSTEXT	280
DPFKDESC2	262	TEXTFIELD	281
EMPTYCOLOR	263	TEXTTEXT	283
ERRCOLOR	263	PFKnn.	283
INITSCRN	264	ENDPANEL	285
MAXOPS	265	Example SDF Definition	285
PFKnn.	265	SDF Tree Structure Definitions.	285
PRIORITY	266	SDF Panel Definitions	287
PRITBSZ	269	SDF Initialization Parameters in AOFINIT	291
PROPDOWN	269	SDF Status Detail Definitions	292
PROPUP	270	Chapter 11. SDF Commands.	293
SCREENSZ	270	SDFTREE.	293
TEMPERR	270	SDFPANEL	294
Chapter 10. SDF Definition Statements	273	SCREEN	295

This part describes the definitions for the status display facility (SDF). Refer to *IBM Tivoli System Automation for z/OS User's Guide* for information on how to set up the display panels and how to use SDF.

Enter the *SDF initialization* parameters in the DSIPARM member of AOFINIT. It is recommended that you use the supplied display defaults.

Chapter 9. SDF Initialization Parameters

The SDF initialization parameters are:

DCOLOR

Default status descriptor color, see “DCOLOR”

DPFK_{nn}

PF key settings for detail status panel, see “DPFK_{nn}” on page 260

DPFKDESC1

PF key descriptions for detail status panel, see “DPFKDESC1” on page 261

DPFKDESC2

PF key descriptions for detail status panel, see “DPFKDESC2” on page 262

EMPTYCOLOR

Default color for status component without a status descriptor, see “EMPTYCOLOR” on page 263

ERRCOLOR

Default color for status component without a tree structure entry, see “ERRCOLOR” on page 263

INITSCRN

Initial screen, see “INITSCRN” on page 264

MAXOPS

Maximum operator logon limit, see “MAXOPS” on page 265

PFK_{nn}

Default PF key settings, see “PFK_{nn}” on page 265

PRIORITY

Priority and color definitions, see “PRIORITY” on page 266

PRITBLSZ

Priority and color table size, see “PRITBLSZ” on page 269

PROPDOWN

Propagate status downward in SDF tree structure, see “PROPDOWN” on page 269

PROPUP

Propagate status upward in SDF tree structure, see “PROPUP” on page 270

SCREENSZ

Screen size, see “SCREENSZ” on page 270

TEMPERR

Temporary error limit value, see “TEMPERR” on page 270

DCOLOR

Purpose

The DCOLOR parameter defines the color used for a status descriptor that is outside any of the defined priority and color ranges. This parameter is optional. If not coded, the program default color is White.

Syntax



Parameters

color

The color used for the status descriptor. This value can be one of the following:

R Red

P Pink

Y Yellow

T Turquoise

G Green

B Blue

W White

The default is White.

Restrictions and Limitations

In member AOFINIT, if the number of PRIORITY parameters (see page 266) exceeds the default PRITBLSZ parameter value of 7 (see page 269), the DCOLOR parameter must follow the PRITBLSZ parameter.

Usage

The recommended value for DCOLOR is White. This value is supplied in the SA z/OS SINGNPRM member AOFINIT. This value does not conflict with existing status and color definitions.

Examples

```
DCOLOR = WHITE
```

DPFKnn

Purpose

The DPFKnn parameter defines all PF keys unique to a detailed status panel.

Syntax



Parameters

nn PF key number. Values can range from 1 to 24. You can modify all PF key definitions.

command

The command executed when the defined PF key is pressed.

Restrictions and Limitations

This parameter must be specified on one line. Continuation lines are not allowed. The total length of the parameter and parameter value specification cannot exceed 72 characters.

PF keys defined by DPFKnn statements are only active when the detail panel is displayed and override the default settings defined with the PFKnn parameter.

Usage

Table 23 shows variables that you can use as part of the command specified on the DPFKnn parameter.

Note: Using these variables (that is, translating variables into values) is valid on a detail status or status panel when the cursor is on a status field.

Table 23. Variables for the DPFKnn Command

Variable	Translated To
&COMP or &RESOURCE	The component name
&ROOT or &SYSTEM	Root or system
&SYSDATE	System date
&SYSTIME	System time
&IN or &INFO	Detail entry information displayed on the status panel
&DATE	The date the detail entry was added
&TIME	The time the detail entry was added
&SENDERID	The reporter submitting the detail entry
&SNODE or &SENDERNODE	The node of the reporter submitting the detail entry
&DA or &DATA or &DSPDETL	The actual message text
&RV or &REFVALUE	The reference value of the detail entry
&PR or &PRIORITY	The priority of the detail entry
&CO or &COLOR	The color of the detail entry
&HI or &HIGHLITE	The highlight level of the detail entry
&RESAPPL or &COMPAPPL	The component name and the alternate component name if used to queue the status
&QCOMP	The component name that the status was queued to by SDF
&DCOMP	The displayed component name

Examples

DPFK9 = SCREEN VTAMSTAT

DPFKDESC1

Purpose

The DPFKDESC1 parameter defines the first part of the PF key description appearing at the bottom of the detail screen. This text is concatenated with the text defined with the DPFKDESC2 parameter.

Syntax

▶▶—DPFKDESC1=*text*—————▶▶

Parameters

text

The text of the detail PF key description. The length of text allowed for this parameter depends on the total parameter length limit (72 characters) and the total text length limit defined by DPFKDESC1 and DPFKDESC2 (80 characters). For example, when defining a detail PF key description that is 79 characters long, you can define the first 60 characters of text on DPFKDESC1 and the remainder of the text on DPFKDESC2.

Restrictions and Limitations

- This parameter must be specified on one line. Continuation lines are not allowed. The total length of the parameter and parameter value specification cannot exceed 72 characters.
- The total length of the PF key description defined by DPFKDESC1 and DPFKDESC2 cannot exceed 80 characters.

Examples

DPFKDESC1=PF3=RET 6=ROLL 7=UP 8=DN 9=AST 10=DEL

DPFKDESC2

Purpose

The DPFKDESC2 parameter defines the second part of the PF key description appearing at the bottom of the detail screen. This text is concatenated with the text defined with the DPFKDESC1 parameter.

Syntax

▶▶—DPFKDESC2=*text*—————▶▶

Parameters

text

The text of the continued PF key description, begun in a previous DPFKDESC1 statement. The length of the text depends on the length specified on the previous DPFKDESC1 statement, because the total description text defined by DPFKDESC1 and DPFKDESC2 cannot exceed 80 characters.

Restrictions and Limitations

- This parameter must be specified on one line. Continuation lines are not allowed. The total length of the parameter and parameter value specification cannot exceed 72 characters.
- The total length of the PF key description defined by DPFKDESC1 and DPFKDESC2 cannot exceed 80 characters.

Examples

DPFKDESC2=11=BOT 12=TOP

EMPTYCOLOR

Purpose

The EMPTYCOLOR parameter defines the color displayed for a status component that has no status descriptor associated with it. This parameter is optional. If not coded, the default color is Blue.

Syntax

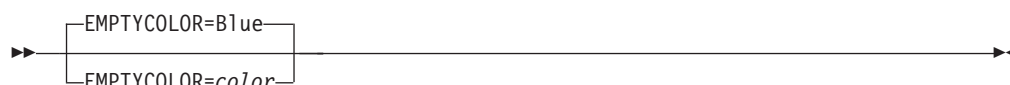

Parameters

color

The color used for the status descriptor. This value can be one of the following:

- R** Red
- P** Pink
- Y** Yellow
- T** Turquoise
- G** Green
- B** Blue
- W** White

The default is Blue.

Usage

The recommended value for EMPTYCOLOR is Blue. This value is supplied in SA z/OS SAOFNPRM member AOFINIT. This value does not conflict with existing status and color definitions. This parameter can be overridden in the AOFTREE member.

Examples

EMPTYCOLOR = BLUE

ERRCOLOR

Purpose

The ERRCOLOR parameter defines the color displayed for a status component that does not have a corresponding entry in the SDF tree structure.

This parameter is optional. If not coded, the default color is White.

ERRCOLOR

Syntax



Parameters

color

The color used for the status component. This value can be one of the following:

R Red

P Pink

Y Yellow

T Turquoise

G Green

B Blue

W White

The default is White.

Examples

```
ERRCOLOR = YELLOW
```

INITSCRN

Purpose

The INITSCRN parameter defines the initial panel displayed by SDF.

Syntax



Parameters

panel_name

Any valid alphanumeric name with maximum length of eight.

Usage

If you change the name of the initial panel defined in the AOFPNLS member of the NetView DSIPARM data set, you must also change the panel name in the INITSCRN parameter.

Examples

```
INITSCRN = SYSTEMA1
```

MAXOPS

Purpose

The MAXOPS parameter defines the maximum number of logged-on operators that can use the SDF. This parameter is optional. If not coded, a program default of 30 is used.

Syntax



Parameters

number

The number of maximum operators. Values can range from 1 to 9999999. The default is 30.

Usage

If the number of operators trying to use the SDF is more than the number defined in MAXOPS, additional operators are denied access to the SDF, because the dynamic update facility keeps an internal count of logged-on operators.

Examples

MAXOPS = 35

PFKnn

Purpose

The PFKnn parameter defines the default PF key settings for SDF panels.

Syntax

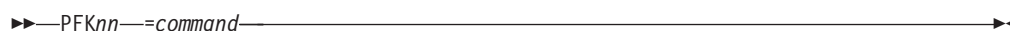

Parameters

nn Values can range from 1 to 24.

command

The command issued when the defined PF key is pressed.

Restrictions and Limitations

This parameter must be specified on one line. Continuation lines are not allowed. The total length of the parameter and parameter value specification cannot exceed 72 characters.

Usage

Table 24 shows the variables that can be used as part of the command specified on the PFKnn parameter.

Note: Use of these variables (that is, their appropriate translation from variables to values) is valid on a detail status panel or on a status panel when the cursor is on a status field.

Table 24. Variables for the PFKnn Command

Variable	Translated To
&COMP or &RESOURCE	The status component
&ROOT or &SYSTEM	Root or system
&SYSDATE	System date
&SYSTIME	System time
&IN or &INFO	Detail entry information displayed on the status panel
&DATE	The date the detail entry was added
&TIME	The time the detail entry was added
&SENDERID	The reporter submitting the detail entry
&SNODE or &SENDERNODE	The node of the reporter submitting the detail entry
&DA or &DATA or &DSPDETL	The actual message text
&RV or &REFVALUE	The reference value of the detail entry
&PR or &PRIORITY	The priority of the detail entry
&CO or &COLOR	The color of the detail entry
&HI or &HIGHLIGHT	The highlight level of the detail entry

Examples

MVS D A,TSO is issued when PF4 is pressed with the cursor placed on the TSO entry on the status screen: PFK4 =MVS D A,&INFO

PRIORITY

Purpose

The PRIORITY parameter defines the relationship between colors and priority ranges. This parameter is optional. If not coded, program defaults are used.

Syntax



Parameters

nnn

The lower limit of the priority range. This value can be any valid number between 001 and 99999999.

mmm

The upper limit of the priority range. This value can be any valid number between 001 and 99999999 and equal to or greater than the value specified in *nnn*.

color

The color used for a particular priority range. This value can be one of the following:

R Red
P Pink
Y Yellow
T Turquoise
G Green
B Blue
W White

program_defaults

These are:

Priority Range	Color
001 to 199	RED
200 to 299	PINK
300 to 399	YELLOW
400 to 499	TURQUOISE
500 to 599	GREEN
600 to 699	BLUE

Restrictions and Limitations

- This parameter must be specified on one line. Continuation lines are not allowed. The total length of the parameter and parameter value specification cannot exceed 72 characters.
- In the AOFINIT member, if the number of PRIORITY parameters defining priority and color ranges (see page 266) exceeds the default PRITBLSZ parameter value of 7 (see page 269), the DCOLOR parameter must follow the PRITBLSZ parameter.
- Default values for priorities and colors are used if and only if no PRIORITY parameters are defined. If you choose to customize any priority and color definitions, you must specify all priority and color definitions in AOFINIT, rather than customizing the one priority and color definition and using the defaults for the remaining definitions.

Usage

It is recommended that you use the priority and color values supplied with SA z/OS DSIPARM member AOFINIT.

PRIORITY

Examples

Priority = 001,199,RED
Priority = 200,299,PINK
Priority = 300,399,YELLOW
Priority = 400,499,TURQUOISE
Priority = 500,599,GREEN
Priority = 600,699,BLUE

PRITBLSZ

Purpose

The PRITBLSZ parameter defines the number of priority and color ranges defined by the PRIORITY entries. This parameter is optional. The default is 7.

Syntax



Parameters

nn The number of priority and color ranges. This value can be any number greater than or equal to 7. The default is 7.

Restrictions and Limitations

In the AOFINIT member, if the number of PRIORITY parameters defining priority and color ranges (see page 266) exceeds the default PRITBLSZ parameter value of 7 (see page 269), the DCOLOR parameter must follow the PRITBLSZ parameter.

Usage

The recommended value for PRITBLSZ is 7. This value is supplied with SA z/OS DSIPARM member AOFINIT.

Examples

PRITBLSZ = 7

PROPDOWN

Purpose

The PROPDOWN parameter defines whether status information should be sent down the status tree as a system default or not. This parameter is optional. The default is NO.

Syntax



Parameters

None.

Usage

The recommended value for PROPDOWN is NO. This parameter can be overridden with individual requests to add a status descriptor to a status component.

PROPUP

PROPUP

Purpose

The PROPUP parameter defines whether status information should be sent up the status tree as a system default. This parameter is optional. The default is YES.

Syntax



Parameters

None.

Usage

The recommended value for PROPUP is YES. This parameter can be overridden with individual requests to add a status descriptor to a status component.

SCREENSZ

Purpose

The SCREENSZ parameter defines the screen buffer size. This parameter is optional. The default is 3000.

Syntax



Parameters

number

Buffer size value. Values can range from 3000 to 9999. The default is 3000.

Examples

```
SCREENSZ = 4000
```

TEMPERR

Purpose

The TEMPERR parameter defines the maximum number of temporary input/output errors when trying to display a SDF panel. This parameter is optional. The default is 3.

Syntax



Parameters

number

Values can range from 3 to 99. The default is 3.

Usage

The recommended value for TEMPERR is 3. This value is supplied with SA z/OS DSIPARM member AOFINIT.

Examples

TEMPERR = 3

TEMPERR

Chapter 10. SDF Definition Statements

The status display facility (SDF) provides a display of automated systems and resources using assigned status colors. An operator monitors the status of automated systems and resources by viewing the SDF main panel.

Typically, an application shown in green on an SDF status panel indicates the application is up, while red indicates the application is stopped or in a problem state. Operators can use the SDF to monitor the system and decide what actions to take when problems occur.

Refer to *IBM Tivoli System Automation for z/OS Defining Automation Policy* for information on how to define the SDF in the customization dialogs. You only need to change these entries if you use values other than the SA z/OS-provided defaults.

AOFTREE

Purpose

AOFTREE is a NetView DSIPARM member containing tree structure definitions, or referencing other tree structure definition members by using %INCLUDE statements. The tree structure definitions specify the propagation hierarchy used for status color changes.

Syntax

Each tree structure definition entry must be in the following format:

►►—*level_number*—*status_component*—,empty_chain_color—►►

Parameters

level_number

The level number assigned to each component in the tree structure. This value can be any valid number between 1 and 9999. A tree structure must start with the root as level number 1.

If a level number is less than that of the preceding status component, the level number used must be defined in the tree structure as a superior node to that status component. For example, the following tree structure definition is *incorrect*:

```
1 SY1
3 APPLIX
2 GATEWAY
```

Multiple roots can be defined in the same member, using 1 as the level number.

status_component

The status component that is associated with the *level_number*. This value can be any application or subsystem that status information is to be displayed

| for. System symbols are supported for the status component name. This can
| help reduce both customization work and errors.

Uses the subsystem entry name as defined in the automation control file. The status component entry for the root must match the SDFROOT value specified on the SA z/OS Environment Setup panel in the customization dialogs that define the current automation policy.

empty_chain_color

The color that a status component is displayed in on the SDF status panel if no status descriptor is associated with a status component. This value can be one of the following:

- R** Red
- P** Pink
- Y** Yellow
- T** Turquoise
- G** Green
- B** Blue
- W** White

This entry is optional. If not coded, the value specified for the SDF initialization parameter EMPTYCOLOR in member AOFINIT is used for this value. Refer to “EMPTYCOLOR” on page 263 for more details.

Usage

When creating tree structure definitions, consider the following:

- Level numbers define the order of dependence. For an example, in Figure 13 on page 275, AOFAPPL is defined to depend on AOFSSI because AOFAPPL relies on AOFSSI for its message traffic. With propagation, any AOFSSI status change is reflected on both AOFAPPL and SY1 status components.
- Duplicate status components in the same tree structure should not be used.
- Not all status components defined in a tree structure require a corresponding panel entry. That is, you can define entries in a tree structure that do not have a corresponding panel display. However, every panel should have a corresponding entry in the tree structure.
- To avoid addressing conflicts, each root name must be unique. SDF addresses each status component defined in the tree structure as `root_component.status_component`

Examples

This example defines two separate tree structures, SY1 and SY2, representing two different MVS systems. SY1 is the focal point and SY2 is the target system.

Figure 13 on page 275 and Figure 14 on page 275 show the tree structures that must be defined in the tree structure definition member for SY1.

Note: /* denotes a comment field.

```
/* TREE STRUCTURE FOR SYSTEM SY1
1 SY1
2 APPLICATION
3 AOFAPPL
4 AOFSSI
```

```
3 JES2
4 SPOOL
3 VTAM
3 RMF
```

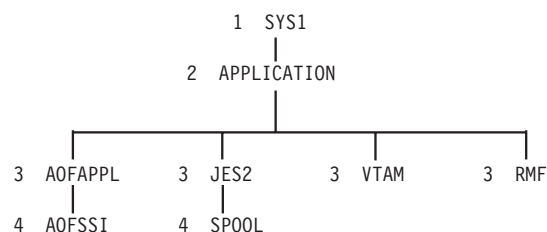

Figure 13. Example Tree Structure Definitions: System SY1. The diagram following the tree structure code for SY1 shows how the order of dependence relates to level number. The diagram is not actually in AOFTREE.

```
/* TREE STRUCTURE FOR SYSTEM SY2 ON SY1
1 SY2
2 APPLICATION
3 AOFAPPL
4 AOFSSI
3 JES2
4 SPOOL
3 VTAM
3 RMF
3 TSO
```

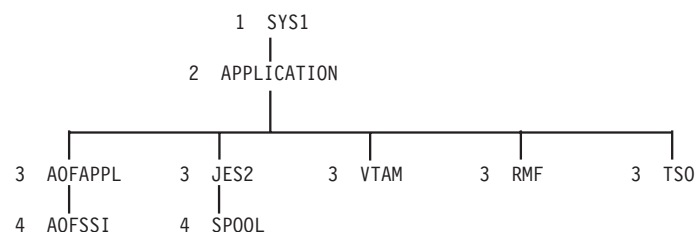

Figure 14. Example Tree Structure Definitions: System SY2. The diagram following the tree structure code for SY1 and SYS2 shows how the order of dependence relates to level number. The diagram is not actually in AOFTREE.

These tree structures are referenced in the AOFTREE member on SY1 by the following %INCLUDE statements:

```
%INCLUDE(SY1TREE)
%INCLUDE(SY2TREE)
```

The AOFTREE member in system SY2 contains only a %INCLUDE statement referencing the tree structure for SY2.

Both tree structures start with level number 1. While the tree structures have unique root names, they can have similar status component names, such as JES2, VTAM, and RMF™. The corresponding settings for the root component can be defined in the system policy and automation setup definitions.

PANEL

Purpose

The PANEL statement identifies the start of a new panel and its general attributes.

Syntax

Parameters are positional.

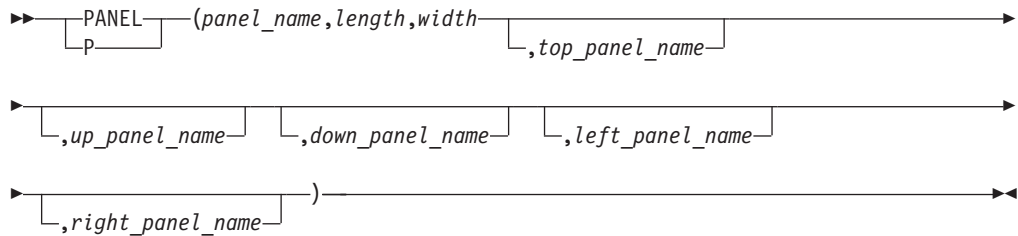

Parameters

panel_name

The name of the panel. This value can be any panel name up to 8 characters long.

length

The number of lines or rows in the panel. This value must be numeric. The only supported value is 24.

width

The number of columns in the panel. This value must be numeric. The only supported value is 80.

top_panel_name

The panel displayed when the TOP PF key is pressed or the TOP command is issued.

up_panel_name

The panel displayed when the UP PF key is pressed or the UP command is issued.

down_panel_name

The panel displayed when the DOWN PF key is pressed or the DOWN command is issued.

left_panel_name

The panel displayed when the left panel PF Key is pressed or the LEFT command is issued.

right_panel_name

The panel displayed when the right panel PF key is pressed or the RIGHT command is issued.

Usage

- The default initial panel name supplied with SA z/OS is SYSTEM. If you change this name, also change the INITSCRN parameter value in the AOFINIT member (see "INITSCRN" on page 264 for details).
- If there is more data than can be displayed on a single screen, you can define continuation panels using the following parameters:

- *left_panel_name*
- *right_panel_name*
- *down_panel_name*
- To continue a PANEL statement on another line after a delimiting comma, leave the remaining columns up to and including column 72 blank. The next positional parameter must begin in column 1 of the following line.

Examples

This example defines SY1SYS as the panel name. The length is 24 lines and the width is 80 characters. The panel named SYSTEM is displayed when the TOP and UP commands are used. No entries are defined for the DOWN, LEFT, or RIGHT commands.

```
PANEL(SY1SYS,24,80,SYSTEM,SYSTEM)
```

STATUSFIELD

Purpose

The STATUSFIELD statement defines the location of the status component on a panel and the panels that display when the UP and DOWN commands are used.

A STATUSFIELD statement is always accompanied by a STATUSTEXT statement (see "STATUSTEXT" on page 280) in a panel definition.

Syntax

Parameters are positional.

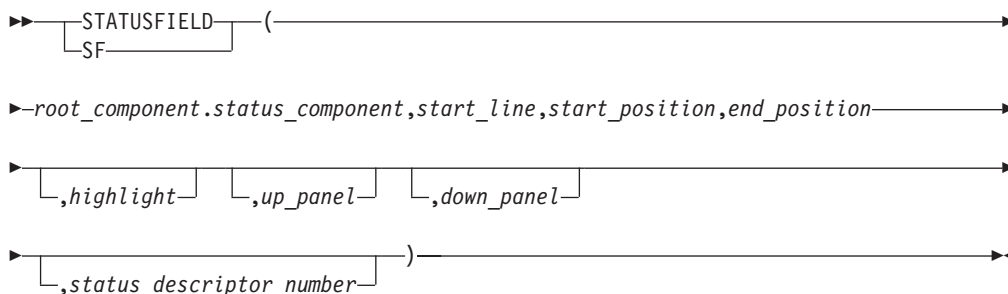

Parameters

root_component

The root component name as defined in the root node of the tree structure. The root component (as opposed to the status component alone) must always be coded, because different systems can have status components with the same name, such as VTAM or JES2, in their tree structures. Because the root component is always unique, each status component in a tree structure can be uniquely identified using the root component as a prefix.

status_component

The status component name as defined in the AOFTREE member. Maximum length is 8 characters.

start_line

The line number that the status component should be displayed on. This value

STATUSFIELD

should be numeric and in the range specified in the *length* parameter in the PANEL definition statement (see "PANEL" on page 276).

start_position

The actual column number within the specified *start_line* that the status component is to be placed on. There must be a minimum of two spaces between the ending position of one field and the beginning position of the next field to allow for attribute type. For example, if the end-position of a STATUSFIELD is in column 10, the start-position of the next STATUSFIELD must be column 13.

end_position

The column number that the status component definition ends in. This value is governed by the length of text defined in the STATUSTEXT definition. For example, if JES2 is to be defined, the length of the STATUSTEXT is four and the end position is the start position plus three. Refer to "STATUSTEXT" on page 280 for more details.

highlight

The type of highlighting used on the panel. This value can be one of the following:

- N Normal
- B Blink
- R Reverse
- U Underscore

The recommended value for highlighting is Normal. This value lets individual status descriptors added to the panel override any predefined highlighting with their own highlighting.

up_panel

The panel displayed when the UP PF key is pressed.

down_panel

The panel displayed when the DOWN PF key is pressed.

status_descriptor_number

The status descriptor number of the panel. This number specifies the status descriptor displayed in each field. This value must be numeric. The default is 0.

A status descriptor number of 0 causes the text as defined in the STATUSTEXT statement for this field (see STATUSTEXT *text* parameter on page 280) to be displayed with the color and highlighting associated with the first status descriptor chained to the status component. A status descriptor of 1 essentially does the same, except that the status text is replaced by information contained in the first status descriptor chained to the status component. A status descriptor of 2 or higher has the same effect as a value of 1, except that the numbered status descriptor is used rather than the first.

Status descriptors are chained with the status component in ascending order of priority.

The status descriptor number may be prefixed with a letter denoting the type of information to be displayed. If no prefix is supplied, the MVS job name is displayed if the resource is a subsystem or WTOR. Valid prefixes are as follows:

- C Displays the name of the status component

- D Displays the date the record was created
- M Displays the associated message text
- P Displays the priority of the record
- Q Displays the reference value for the record
- R Displays the name of the root component
- S Displays the reporting operator ID
- T Displays the time the record was created
- U Displays the number of duplicate records
- V Displays the job name or other information about the request
- X Displays the reporting domain ID

Restrictions and Limitations

A *start_line* and *start_position* parameter value combination of 1,1 is not allowed.

SDF panels containing STATUSFIELD entries referring to other than the first status descriptor may not be updated dynamically if the panel is not made resident either using the SDFPANEL ...,ADD command, or during SDF initialization. Automatic updates on dynamically loaded panels may be obtained by coding a dummy panel containing STATUSFIELD entries referring to the status component with a status descriptor number greater than 1.

At least one undefined (blank) position must be provided immediately preceding a STATUSFIELD. If *start_position* is specified as 1, the last position on the preceding line must not be defined.

Usage

- When designing a panel for any status component, make the end position greater than or equal to the start position. Otherwise, an error condition will occur during SDF initialization.
- To continue a STATUSFIELD statement on another line after a delimiting comma, leave the remaining columns up to and including column 72 blank. The next positional parameter must begin in column 1 of the following line. An example of a continued STATUSFIELD statement is:

```
STATUSFIELD(SY.VTAM,
04,10,13,NORMAL)
```
- For better performance, make sure that every status component referred to in the panel is defined in the corresponding AOFTREE member.

Examples

Example 1

In this example, the status component VTAM on SY1 starts on line 4 in column 10, ends in column 13, and has normal highlighting. No entries are defined for the UP or DOWN commands.

```
STATUSFIELD(SY1.VTAM,04,10,13,NORMAL)
:
:
```

Example 2

STATUSFIELD

In this example, the status component SYSTEM starts on line 2 in column 04, ends in column 06, and has normal highlighting. No entries are defined for the UP panel. Panel SY1SYS is displayed when the DOWN command is issued.

```
SF(SY1.SYSTEM,02,04,06,N,,SY1SYS)
:
:
```

Example 3

In this example, three STATUSFIELD entries are defined for the same status component, SY1.GATEWAY. The highest-priority status descriptor is displayed in the first entry, the next highest-priority status descriptor is displayed in the second entry, and so on.

```
SF(SY1.GATEWAY,02,04,06,NORMAL,,1)
SF(SY1.GATEWAY,03,04,06,NORMAL,,2)
SF(SY1.GATEWAY,04,04,06,NORMAL,,3)
:
:
```

STATUSTEXT

Purpose

The STATUSTEXT statement defines the text data displayed in the STATUSFIELD statement (see “STATUSFIELD” on page 277). This text data is typically the status component name.

Syntax

```
→ STATUSTEXT text →
  |
  | ST
```

Parameters

text

The default data displayed for the status component defined in the STATUSFIELD statement. This text can be replaced by text from a status descriptor chained to the status component if the *status_descriptor_number* parameter value on the corresponding STATUSFIELD statement is non-zero. The recommended value is the status component name. For example, for status component SY1.VTAM, specify VTAM for the *text* value. The length of text determines the end position coded in the STATUSFIELD statement.

Restrictions and Limitations

- Each STATUSFIELD statement must have a STATUSTEXT statement associated with it in a panel definition.
- The total length of the STATUSTEXT text cannot exceed the status field length defined by the combination of STATUSFIELD *start_position* and *end_position* parameter values.

Usage

To continue a STATUSTEXT statement, insert a delimiting comma and leave the remaining columns up to and including column 72 blank. Resume the text definition in column 1 of the following line.

Examples

Example 1

The following statement defines status text 1234567890 for a status field:

```
STATUSTEXT(12345,
67890)
```

Example 2

This example defines that IMS on SY2 displays as ACCOUNTS on the status display panel. Any status descriptors added for SY2.IMS are displayed using the ACCOUNTS entry.

Note: The end position in the STATUSFIELD statement reflects the length of ACCOUNTS.

```
STATUSFIELD(SY2.IMS,06,10,17,NORMAL)
STATUSTEXT(ACCOUNTS)
```

TEXTFIELD

Purpose

The TEXTFIELD statement defines the location and attributes of fields that remain constant on the panels, such as panel headings, field names, and PF key designations.

Each TEXTFIELD statement must have a TEXTTEXT statement associated with it (see "TEXTTEXT" on page 283) in a panel definition.

Syntax

Parameters are positional.

```

TEXTFIELD (start_line,start_position,end_position
           [,color]
           [,highlight])

```

Parameters

start_line

The line number that the text field is displayed on. This value should be numeric and in the range specified in the *length* parameter in the PANEL definition statement (see "PANEL" on page 276).

start_position

The column number that the text field is placed in.

end_position

The column number that the data specified in entry TEXTTEXT ends in. Refer to "TEXTTEXT" on page 283 for more details.

color

The color that text specified in the corresponding TEXTTEXT statement is displayed in. This value can be one of the following:

TEXTFIELD

- R Red
- P Pink
- Y Yellow
- T Turquoise
- G Green
- B Blue
- W White

highlight

Determines how the text specified in the corresponding TEXTTEXT statement is displayed. This value can be one of the following:

- N Normal
- B Blink
- R Reverse
- U Underscore

Restrictions and Limitations

- A *start_line* and *start_position* parameter value combination of 1,1 is not allowed.
- If your text definition for an area of a panel requires more than 72 characters, continue the definition in additional TEXTFIELD and TEXTTEXT statement pairs. See the examples in "TEXTTEXT" on page 283 for an example of continuing definitions in additional TEXTFIELD and TEXTTEXT pairs.
- At least two undefined (blank) positions must be provided immediately preceding a TEXTFIELD if it follows a STATUSFIELD. If *start_position* is specified as 1, the last two positions on the preceding line must not be defined.
- At least one undefined (blank) position must be provided immediately preceding a TEXTFIELD if it follows another TEXTFIELD. If *start_position* is specified as 1, the last position on the preceding line must not be defined.

Usage

- When designing a panel, for any TEXTFIELD, make the *end_position* of the TEXTFIELD greater than or equal to the *start_position*. Otherwise, an error condition will occur during SDF initialization.
- To continue a TEXTFIELD statement on another line after a delimiting comma, leave the remaining columns up to and including column 72 blank. The next positional parameter must begin in column 1 of the following line. An example continued TEXTTEXT statement is:

```
TEXTFIELD(01,  
25,57,WHITE,NORMAL)
```

Examples

This example defines the TEXTFIELD as being on line 1, starting in column 25, ending in column 57. The text is displayed in white, and uses normal highlighting.

```
TEXTFIELD(01,25,57,WHITE,NORMAL)
```

The definitions defined by PFKnn are only active when the status panel is displayed. They override the default settings defined with the initialization PFKnn statement in member AOFINIT (see “PFKnn” on page 265).

Syntax

» PFKnn (command [,—variable])

Parameters

nn The PF key number. This value can range from 1 through 24.

command

The command called when the defined PF key is pressed. If you need to use commas in the command, enclose the entire command string in apostrophes.

variable

Variables can be used as part of the command specified in the PFKnn statement. Table 25 shows variables that can be used.

Note: Use of these variables (that is, their appropriate translation from variables to values) is valid on a detail status panel or on a status panel when the cursor is on a status field.

Table 25. Variables for PF Keys

Variables for Text Fields	Translated To
&COMP or &RESOURCE	The component name
&ROOT or &SYSTEM	Root or system
&SYSDATE	System date
&SYSTIME	System time
&IN or &INFO	Detail entry information displayed on the status panel
&DATE	The date the detail entry was added
&TIME	The time the detail entry was added
&SENDERID	The reporter submitting the detail entry
&SNODE or &SENDERNODE	The node of the reporter submitting the detail entry
&DA or &DATA or &DSPDETL	The actual message text
&RV or &REFVALUE	The reference value of the detail entry
&PR or &PRIORITY	The priority of the detail entry
&CO or &COLOR	The color of the detail entry
&HI or &HIGHLITE	The highlight level of the detail entry
&RESAPPL or &COMPAPPL	The component name and the alternate component name if used to queue the status
&QCOMP	The component name that the status was queued to by SDF
&DCOMP	The displayed component name

Examples

This example results in issuing MVS D A, TSO when PF4 is pressed and the cursor is on the TSO entry: PFK4('MVS D A, &INFO')

SDF Definitions

```
1 SY1
2 SYSTEM
3 JES
3 RMF
3 VTAM
3 TSO
3 AOFAPPL
4 AOFSSI
3 APPLIC
4 SUBSYS
2 ACTION, GREEN
3 WTOR, GREEN
2 GATEWAY
```

Figure 15. SDF Example: Tree Structure Definition for SY1

Figure 16 shows the hierarchy of monitored resources defined by the SY1 tree structure.

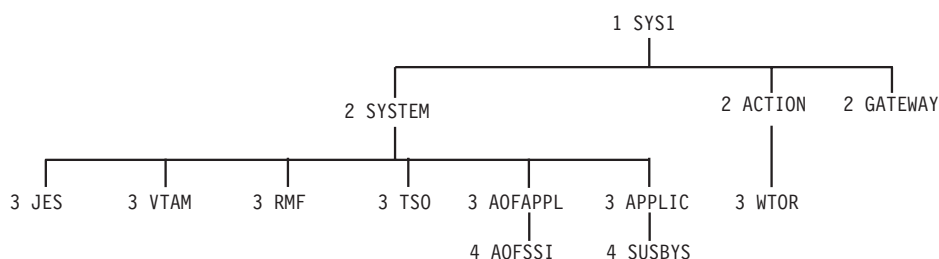

Figure 16. SDF Example: Hierarchy Defined by SY1 Tree Structure. The diagram shows how the order of dependence relates to level number. The diagram is not actually in AOFTREE.

This structure contains specific entries for the major system components, JES, RMF, VTAM, and TSO, as well as NetView (AOFAPPL) and the NetView SSI (AOFSSI). Note that the hierarchy differs from that defined in the SA z/OS automation control file. This is because the operator's view of these subsystems differs from the logical sequence that they are managed in by SA z/OS for startup and shutdown purposes.

The SYSTEM, APPLIC, and ACTION entries are logical, and may be used to view the status of all entries below them in priority order.

The SUBSYS, WTOR, and GATEWAY entries are also logical, and may be used to display the status of SUBSYSTEM, WTOR, and GATEWAY resource types. The status of any subsystem not appearing elsewhere in the tree will be queued under the SUBSYS entry. Similarly, WTORs and gateway status will be queued under WTOR and GATEWAY respectively.

A similar tree structure must be provided for SY2. As both systems are running the same set of base software, the tree structures are identical, except for the root (level 1) name, which will be SY2 rather than SY1. This tree structure is defined in the SY2TREE NetView DSIPARM member.

As SY1 is the focal point system in this example, both members must be defined in the NetView DSIPARM data set on that system. The tree structures are referenced by %INCLUDE statements in the base SDF tree definition member, AOFTREE, as follows:

```
%INCLUDE(SY1TREE)
%INCLUDE(SY2TREE)
```

As our example does not require SY2 to function as a backup focal point system, the AOFTREE member on SY2 requires only the %INCLUDE statement for SY2TREE.

SDF Panel Definitions

Following are panel definitions for:

- The root component or system panel, named SYSTEM
- The status component panel for system SY1, named SY1

Each panel definition is followed by the screen it defines.

SA z/OS provides samples similar to those described, as well as a sample GATEWAY panel definition for use on SY1.

On system SY1, these panel definitions are referenced by %INCLUDE statements in the main SDF panel definition member, AOFPNLS, as follows:

The GATEWAY, SY1, and SY2 panels must be resident as they contain generic field definitions.

```
%INCLUDE(SYSTEM)
%INCLUDE(GATEWAY)
%INCLUDE(SY1)
%INCLUDE(SY2)
```

Root Component Panel Definition

First, the root panel, named SYSTEM, is defined. Figure 17 shows the panel definition statements that define the SYSTEM panel. This panel is the default initial SDF panel as assigned in the SDF initialization parameter member, AOFINIT. Three panels are accessed by pressing the DOWN PF key (PF8), GATEWAY, SY1, and SY2. All status components are prefixed with the root component and are listed in the corresponding tree structure. Each STATUSFIELD (SF) statement is followed by the corresponding STATUSTEXT (ST) statement. Similarly, each TEXTFIELD (TF) statement is followed by the corresponding TEXTTEXT (TT) statement.

```
/* DEFINE SYSTEM STATUS PANEL
P(SYSTEM,24,80)
TF(01,02,10,WHITE,NORMAL)
TT(SYSTEM)
TF(01,25,57,WHITE,NORMAL)
TT(DATA CENTER SYSTEMS)
SF(SY1.SYSTEM,04,04,11,N,,SY1)
ST(SY1)
SF(SY2.SYSTEM,06,04,11,N,,SY2)
ST(SY2)
SF(SY1.GATEWAY,02,70,77,N,,GATEWAY)
ST GATEWAY
TF(24,01,48,T,NORMAL)
TT(1=HELP 2=DETAIL 3=RET          6=ROLL    8=DN)
TF(24,51,79,T,NORMAL)
TT(          10=LF 11=RT 12=TOP)
EP
```

Figure 17. SDF Example: System Panel Definition Statements

This panel shows the layout defined by the statements in Figure 17:

SDF Definitions

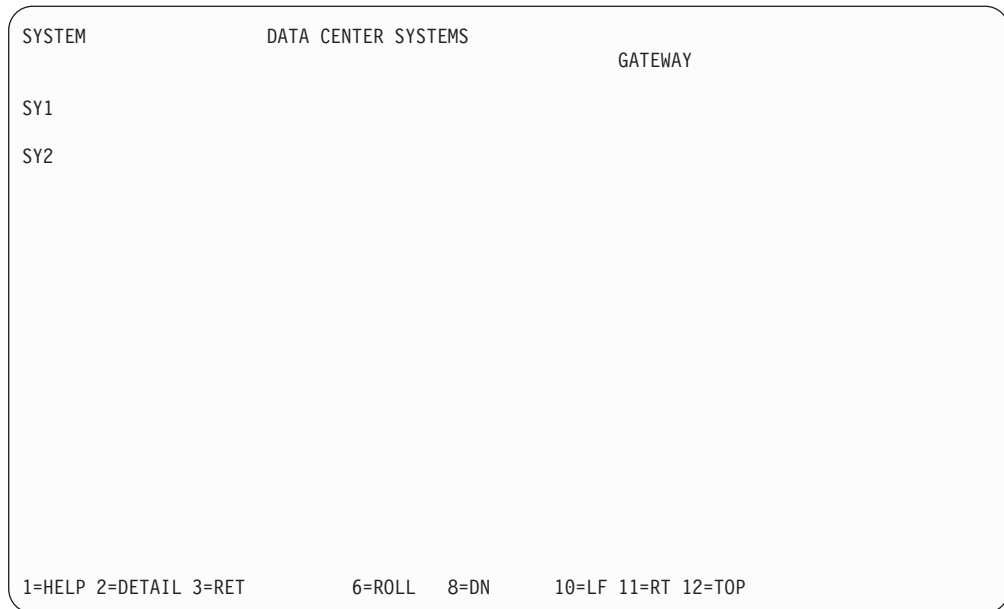

Status Component Panel Definition

Next, the panels for the status components, SY1 and SY2, are defined. These panels can be accessed by pressing the DOWN PF key (PF8) on the root component panel, after placing the cursor under the desired system name. They can also be accessed directly by entering SDF SY1 or SDF SY2 from the NetView NCCF command line, or entering SCREEN SY1 from within SDF.

Because these panels contain dynamic status elements, it is necessary for them to be made resident. This is done by referring to them in %INCLUDE statements in the main SDF panel definition member.

Figure 18 on page 289 shows a sample panel definition for panel SY1.

```

/* Panel definition statements for SY1 panel
P(SY1,24,80,SYSTEM,SYSTEM)
TF(01,02,10,WHITE,NORMAL)
TT(SY1)
TF(01,27,47,WHITE,NORMAL)
TT(SY1 SYSTEM STATUS)
SF(SY1.JES,04,16,24,N)
ST(JES)
SF(SY1.RMF,06,16,24,N)
ST(RMF)
SF(SY1.VTAM,08,16,24,N)
ST(VTAM)
SF(SY1.TSO,10,16,24,N)
ST(TSO)
SF(SY1.AOFAPPL,12,16,24,N)
ST(NetView)
SF(SY1.AOFSSI,14,18,28,N)
ST(NetView SSI)
SF(SY1.WTOR,4,45,50,N)
ST(WTORs:)
SF(SY1.WTOR,4,53,56,N,,c1)
SF(SY1.WTOR,4,59,67,N,,1)
SF(SY1.WTOR,5,53,56,N,,c2)
SF(SY1.WTOR,5,59,67,N,,2)
SF(SY1.WTOR,6,53,56,N,,c3)
SF(SY1.WTOR,6,59,67,N,,3)
SF(SY1.WTOR,7,53,56,N,,c4)
SF(SY1.WTOR,7,59,67,N,,4)
SF(SY1.APPLIC,9,45,57,N)
ST(Applications:)
SF(SYS1.APPLIC,9,59,67,N,,1)
SF(SYS1.APPLIC,10,59,67,N,,2)
SF(SYS1.APPLIC,11,59,67,N,,3)
SF(SYS1.APPLIC,12,59,67,N,,4)
SF(SYS1.APPLIC,13,59,67,N,,5)
SF(SYS1.APPLIC,14,59,67,N,,6)
PFK4('SDFDEL &ROOT.&RESAPPL,RV=&RV,DATE=&DATE,TIME=&TIME')
TF(24,01,79,T,NORMAL)
TT('1=HELP 2=DETAIL 3=RET          6=ROLL 7=UP      '
'          10=LF 11=RT 12=TOP')
EP(SY1)

```

Figure 18. SDF Example: Status Component Panel Definition Statements for SY1SYS

A similar panel reflecting the status of components on SY2 can be created by changing all occurrences of SY1 to SY2 in the above example.

Figure 19 on page 290 shows the layout defined by the statements in Figure 18.

Note: Three of the four available WTOR dynamic fields have been filled with the WTOR number and the name of the job that issued them. WTORs will appear whether or not their source is defined to SA z/OS.

SY1	SY1	SYSTEM	STATUS
JES		WTORs: 14	MSGPROC
18	NETVIEW		
RMF		22	MYJOB
VTAM			
Applications:	MSGPROC		
TSO			WTR00E
IMS			
NetView			CICS
ETC1			
NetView SSI			ETC2

1=HELP 2=DETAIL 3=RET 4=DELETE 6=ROLL 7=UP 10=LF 11=RT 12=TOP

Figure 19. Sample SY1 SDF Panel

The fields defined for JES, RMF, VTAM, TSO, NetView and the NetView SSI are static in that only the color of the predefined status text changes when the highest priority status descriptor that is queued for the underlying status component changes. The fields defining WTORs: and Applications: are also static, but do not refer to a specific subsystem. These fields will also assume the color of the highest priority status descriptor that is queued. The WTORs: field is green when no replies are outstanding due to the SDF tree definition for the underlying status component, SY1.WTOR. The remaining static fields will appear turquoise, or the EMPTYCOLOR that is defined in the AOFINIT NetView DSIPARM member.

The status fields following WTORs: and Applications: are dynamic in that both their content and color depend on the status descriptor that they represent. The ability to select both the type of data and the status descriptor number that the data is obtained from allows generic status fields to be defined (see “STATUSFIELD” on page 277). This takes advantage of an SDF feature that allows the status descriptor to be queued under an alternate component should the primary status component not be defined in the SDF tree structure. For subsystems, the status component name is the subsystem name, and the alternate component is SUBSYS. WTORs are queued using the reply ID as the status component name, and WTOR as the alternate component name.

The use of generic field definitions has several advantages, and may considerably reduce the amount of maintenance required, particularly in large, multisystem environments. Using this method, the status components are displayed in priority order, so the most critical status subsystem is presented first. Also, if more subsystems are defined to SA z/OS than are defined on the panel, you will be notified of only the most critical situations. It is also possible to continue the list of statuses presented on additional panels if required.

You should note that using this method, subsystems do not always appear in the same position on the panel, which may make it difficult to find a specific subsystem. Also, some transient conditions can cause a subsystem to appear twice on the display. This can be eliminated by changing the SDF Status Detail definition to CLEAR=Y for the transient status definitions.

SDF Initialization Parameters in AOFINIT

For this example, the default AOFINIT entries supplied with SA z/OS are used. For more information on setting SDF initialization parameters refer to Chapter 9, "SDF Initialization Parameters," on page 259.

```

SCREENSZ = 3000
INITSCRN=SYSTEM
MAXOPS=10
PROPUP=YES
PROPDOWN=NO
TEMPERR=3
/* STATUS PANEL PF KEYS AND DESCRIPTION */
PFK1=AOCHELP SDF
PFK2=DETAIL
PFK3=RETURN
PFK4=
PFK5=
PFK6=ROLL
PFK7=UP
PFK8=DOWN
PFK9=
PFK10=LEFT
PFK11=RIGHT
PFK12=TOP
PFK13=AOCHELP SDF
PFK14=DETAIL
PFK15=RETURN
PFK16=
PFK17=
PFK18=ROLL
PFK19=UP
PFK20=DOWN
PFK22=LEFT
PFK23=RIGHT
PFK24=TOP
/* DETAIL PANEL PF KEYS AND DESCRIPTION */
DPFK1=AOCHELP SDF
DPFK2=
DPFK3=RETURN
DPFK4=
DPFK5=
DPFK6=ROLL
DPFK7=UP
DPFK8=DOWN
DPFK10=SDFDEL &ROOT,&COMPAPPL,RV=&RV,DATE=&DATE,TIME=&TIME
DPFK11=BOT
DPFK12=TOP
DPFK13=AOCHELP SDF
DPFK14=
DPFK15=RETURN
DPFK16=
DPFK17=
DPFK18=ROLL
DPFK19=UP
DPFK20=DOWN
DPFK22=SDFDEL &ROOT.&COMPAPPL,RV=&RV,DATE=&DATE,TIME=&TIME
DPFK23=BOT
DPFK24=TOP
DPFKDESC1=1=HELP      3=RETURN      6=ROLL 7=UP 8=DOWN
DPFKDESC2=10=DELETE 11=BOTTOM 12=TOP
/* PRIORITY/COLOR RELATIONSHIPS (DEFAULT VALUES)
PRITBSZ=7
PRIORITY=1,199,RED
PRIORITY=200,299,PINK
PRIORITY=300,399,YELLOW
PRIORITY=400,499,TURQUOISE

```

SDF Definitions

```
PRIORITY=500,599,GREEN
PRIORITY=600,699,BLUE
DCOLOR=WHITE
EMPTYCOLOR=BLUE
```

Note: /* denotes a comment field, where /* must be followed by a blank.

SDF Status Detail Definitions

In Figure 20 the default SDF Status Details definitions supplied with SA z/OS are used. For further information on how to set SDF Status Detail fields, refer to *IBM Tivoli System Automation for z/OS User's Guide*. These entries are stored in NetView DSIPARM data set member AOFSDF, and are automatically included in the master automation control file.

Note: Do not rename the AOFSDF member %INCLUDE AOFSDF.

Status	Priority	Highlight	Color	Clear	Srv Req(noadd)
RWTOR				(Y,RV)	NOADD
SPLGONE				(Y,RV)	NOADD
COMMLOST	110	REVERSE	RED	Y	
BROKEN	120	REVERSE	RED	(Y,RV*)	
BREAKING	130	BLINK	RED	(Y,RV*)	
INACTIVE	140	UNDERSCORE	RED	(Y,RV*)	
IWTOR	150		RED	Y	
SPLFULL	150		RED	(Y,RV)	
STOPPED	150	NORMAL	RED	(Y,RV*)	
HALFDOWN	220	NORMAL	PINK	(Y,RV*)	
STARTED2	230	BLINK	PINK	(Y,RV*)	
STUCK	240	UNDERSCORE	PINK	(Y,RV*)	
ZOMBIE	250	REVERSE	PINK	(Y,RV*)	
ABENDING	320	REVERSE	WHITE	(Y,RV*)	
HALTED	330	UNDERSCORE	WHITE	(Y,RV*)	
SPLSHORT	350		YELLOW	(Y,RV)	UWTOR 350 YELLOW Y
STOPPING	420	REVERSE	YELLOW	(Y,RV*)	
AUTOTERM	430	NORMAL	YELLOW	(Y,RV*)	
ENDING	440	UNDERSCORE	YELLOW	(Y,RV*)	
RUNNING	520	BLINK	TURQUOISE	(Y,RV*)	
ACTIVE	530	REVERSE	TURQUOISE	(Y,RV*)	
STARTED	540	UNDERSCORE	TURQUOISE	(Y,RV*)	
EXTSTART	550	BLINK	TURQUOISE	(Y,RV*)	
NWTOR	550		GREEN	Y	
RESTART	550	NORMAL	TURQUOISE	(Y,RV*)	
SPLOK	550		GREEN	Y	
UP	640	NORMAL	GREEN	(Y,RV*)	
ENDED	650	UNDERSCORE	GREEN	(Y,RV*)	
DOWN	730	UNDERSCORE	BLUE	(Y,RV*)	
AUTODOWN	740	NORMAL	BLUE	(Y,RV*)	
CTLDOWN	750	BLINK	BLUE	(Y,RV*)	
MOVED	760	REVERSE	BLUE	(Y,RV*)	
FALLBACK	770	NORMAL	BLUE	(Y,RV*)	

Figure 20. Default Values for SDF Displays

Chapter 11. SDF Commands

SDFTREE

Purpose

SDFTREE dynamically loads an SDF tree structure definition member from the NetView DSIPARM data set or deletes a tree member from system memory.

SDFTREE can be issued from a console.

Syntax

To load or delete a tree structure definition member use the following syntax:

```
▶▶ SDFTREE [tree_member,ADD | root_component_name,DELETE] ▶▶
```

Parameters

tree_member

The name of the member containing the tree structure to load.

root_component_name

The name of the root component, which is the name used for level 1 in the tree structure you want to delete. While you add a tree structure definition members by specifying a tree member name, you delete tree structure definition members by specifying a root component name.

ADD

Specifies that you want to add the specified tree structure definition member.

DELETE

Specifies that you want to delete a tree structure definition member.

Restrictions and Limitations

Tree structure definition members dynamically loaded by the SDFTREE command are not reloaded when SDF is restarted. When SDF is restarted, only members AOFTREE and any members referenced by %INCLUDE statements in AOFTREE are reloaded. You must either add the tree definitions to AOFTREE (using %INCLUDE statements) before SDF is restarted, or manually reload them using the SDFTREE command after SDF is restarted.

Usage

- When a new tree structure is loaded to replace an existing tree structure, the status descriptors of any status component with identical names in both trees are copied to the new tree.
- When an error is detected while this command is processing, no action is taken to change the existing tree structure.

Examples

SDFTREE NEWTREE,ADD loads member NEWTREE into system memory. This loading allows operators to access the tree structure defined in NEWTREE.

SDFPANEL

Purpose

SDFPANEL dynamically loads a panel member from the NetView DSIPARM data set or deletes a panel member.

SDFPANEL can be issued from a console.

Syntax

To add or delete a panel member use the following syntax:

```

▶▶ SDFPANEL panel_member,ADD panel_name,DELETE

```

Parameters

panel_member

The name of the member containing the panel to load.

panel_name

The name of the panel to delete. While you add panels by specifying the panel member name, you delete panels by specifying the actual panel name.

ADD

Specifies that you want to add the specified panel member.

DELETE

Specifies that you want to delete the specified panel.

Restrictions and Limitations

Panel definition members dynamically loaded by the SDFPANEL command are not reloaded when SDF is restarted. Only member AOFPNLS and any members referenced by %INCLUDE statements in AOFPNLS are reloaded. You must either add the panel definitions to AOFPNLS (using %INCLUDE statements) before SDF is restarted, or manually reload them using the SDFPANEL command after SDF is restarted.

Usage

When an error is detected while this command is processing, no action is taken to change the existing panel definitions. For example, if one of several panels defined or referenced by %INCLUDE statements in a panel definition member contains an error, none of the panels are placed into active use.

Examples

SDFPANEL NEWPANEL,ADD loads member NEWPANEL into memory. This loading allows operators to access the panel defined in NEWPANEL.

SCREEN

Purpose

The SCREEN command displays a specific SDF panel.

SCREEN can be issued only within SDF.

Syntax

►—SCREEN—*panel_name*—◄

Parameters

panel_name

The name of the panel to be displayed. *panel_name* is the name of the panel as it appears in the upper left hand corner of the screen.

Restrictions and Limitations

None.

Usage

- If the specified panel is not in memory when the SCREEN command is issued, the NetView DSIPARM data set is searched for a member name matching the specified panel name. If one is found, that member is loaded for the operator that the request was made from, and the panel defined in the member is displayed.
- If an error is detected in a panel you attempt to load using the SCREEN command, the panel is not displayed.
- If you plan to use the SCREEN command frequently in your SDF implementation, you might want to define a PF key that issues the SCREEN command.

Examples

SCREEN SY1 displays the panel named SY1.

Dynamically Loading Panels and Tree Structures

You can dynamically load panels and tree structures without restarting SDF. With this dynamic loading, you can load a small number of panels during initialization, and add or delete panel subsets when required during SDF operation. This can significantly reduce the number of panels kept resident at any one time.

When you are dynamically loading panels or tree structures, there must be a member in the NetView DSIPARM data set with the same name as the panel name or the root component in the tree structure. If not, a “not found” error message is generated.

Note: Only panels loaded with the SDFPANEL command are available to all logged-on SA z/OS operators. All others are loaded only for the operator calling them.

Dynamically Loading Panels

SCREEN

You can load panels dynamically in the following ways:

- With the SDFPANEL command, as described in “SDFPANEL” on page 294.
- With the SCREEN command, as described in “SCREEN” on page 295.
- When any of the following PANEL statement parameters call a panel not defined in AOFPNLS, and a member with the same name as that panel is found in the NetView DSIPARM data set:

- *top_panel_name*
- *up_panel_name*
- *down_panel_name*
- *left_panel_name*
- *right_panel_name*

See “PANEL” on page 276 for the PANEL statement description.

Note: Performance hint: Dynamically loading panels reduces storage requirements. However, using the SCREEN command or PANEL statements that refer to the panels not defined in AOFPNLS can result in increased processor usage. For better performance, ensure the panels are included in the AOFPNLS member either directly or by an %INCLUDE.

Dynamically Loading Tree Structures

You can load SDF tree structures dynamically with the SDFTREE command, as described in “SDFTREE” on page 293.

When you load a new tree structure to replace an existing one, any status descriptors with identical names in both tree structures are copied to the new tree structure.

Dynamic Loading Example

Suppose you change the tree structure for root component SY1 and the panel named SY1SYS. The tree structure and panel definitions are maintained in separate members (instead of being directly coded in AOFTREE or AOFPNLS). Use the following commands to load the new definitions:

```
SDFTREE SY1,ADD  
SDFPANEL SY1SYS,ADD
```

For more information, see “SDFTREE” on page 293 and “SDFPANEL” on page 294.

Dynamic Loading Commands

Use the following commands to dynamically load SDF tree structures and panels, and to confirm that a panel was loaded:

SDFTREE

Load Tree Structure Definition Member

SDFPANEL

Load Panel Definition Member

SCREEN

Display a SDF Panel

When an error is detected while any of these dynamic loading commands is processing, no action is taken to change the existing tree structure or panel

definitions. For example, if one of several panels defined or referenced by %INCLUDE statements in a panel definition member contains an error, none of the panels are placed into active use. Similarly, if an error is detected in a panel you attempt to load using the SCREEN command, the panel is not displayed.

Verifying Dynamic Loading of Panels

Use the SCREEN command to verify that a panel was correctly loaded. See “SCREEN” on page 295 for the SCREEN command description.

You might want to create a test version of a panel you are modifying and display it using the SCREEN command to verify that your changes are correct. To do this:

1. Copy the existing panel definition member into another panel definition member.
2. Modify the panel definition statements in the new panel definition member. Use a different name for the panel on the PANEL statement.
3. Use the SCREEN command to verify that the changes to the panel are correct.
4. If you see anything in the displayed panel that should change, correct the panel definition statements.
5. Rename the panel to the name used for the production version of the panel. To do this, change the name specified on the PANEL statement.
6. Use the SDFPANEL command to load the new panel and put it into production. This SDFPANEL command causes the new panel to overwrite the old panel.

SCREEN

Glossary

This glossary includes terms and definitions from:

- The *IBM Dictionary of Computing* New York: McGraw-Hill, 1994.
- The *American National Standard Dictionary for Information Systems*, ANSI X3.172-1990, copyright 1990 by the American National Standards Institute (ANSI). Copies can be purchased from the American National Standards Institute, 1430 Broadway, New York, New York 10018. Definitions are identified by the symbol (A) after the definition.
- The *Information Technology Vocabulary* developed by Subcommittee 1, Joint Technical Committee 1, of the International Organization for Standardization and the International Electrotechnical Commission (ISO/IEC JTC1/SC1). Definitions of published parts of this vocabulary are identified by the symbol (I) after the definition; definitions taken from draft international standards, committee drafts, and working papers being developed by ISO/IEC JTC1/SC1 are identified by the symbol (T) after the definition, indicating that final agreement has not yet been reached among the participating National Bodies of SC1.

The following cross-references are used in this glossary:

Contrast with. This refers to a term that has an opposed or substantively different meaning.

Deprecated term for. This indicates that the term should not be used. It refers to a preferred term, which is defined in its proper place in the glossary.

See. This refers the reader to multiple-word terms in which this term appears.

See also. This refers the reader to terms that have a related, but not synonymous, meaning.

Synonym for. This indicates that the term has the same meaning as a preferred term, which is defined in the glossary.

Synonymous with. This is a backward reference from a defined term to all other terms that have the same meaning.

A

ACF. Automation control file.

ACF/NCP. Advanced Communications Function for the Network Control Program. See *Advanced Communications Function* and *Network Control Program*.

ACF/VTAM. Advanced Communications Function for the Virtual Telecommunications Access Method. Synonym for *VTAM*. See *Advanced Communications Function* and *Virtual Telecommunications Access Method*.

active monitoring. In SA z/OS, the acquiring of resource status information by soliciting such information at regular, user-defined intervals. See also *passive monitoring*.

adapter. Hardware card that enables a device, such as a workstation, to communicate with another device, such as a monitor, a printer, or some other I/O device.

Address Space Workflow. In RMF, a measure of how a job uses system resources and the speed at which the job moves through the system. A low workflow indicates that a job has few of the resources it needs and is contending with other jobs for system resources. A high workflow indicates that a job has all the resources it needs to execute.

adjacent hosts. Systems connected in a peer relationship using adjacent NetView sessions for purposes of monitoring and control.

adjacent NetView. In SA z/OS, the system defined as the communication path between two SA z/OS systems that do not have a direct link. An adjacent NetView is used for message forwarding and as a communication link between two SA z/OS systems. For example, the adjacent NetView is used when sending responses from a focal point to a remote system.

Advanced Communications Function (ACF). A group of IBM licensed programs (principally VTAM, TCAM, NCP, and SSP) that use the concepts of Systems Network Architecture (SNA), including distribution of function and resource sharing.

advanced program-to-program communication (APPC). A set of inter-program communication services that support cooperative transaction processing in a Systems Network Architecture (SNA) network. APPC is the implementation, on a given system, of SNA's logical unit type 6.2.

alert. (1) In SNA, a record sent to a system problem management focal point or to a collection point to communicate the existence of an alert condition. (2) In NetView, a high-priority event that warrants immediate

attention. A database record is generated for certain event types that are defined by user-constructed filters.

alert condition. A problem or impending problem for which some or all of the process of problem determination, diagnosis, and resolution is expected to require action at a control point.

alert focal-point system. See entry for NPDA focal-point system under *focal-point system*.

alert threshold. An application or volume service value that determines the level at which SA z/OS changes the associated icon in the graphical interface to the alert color. SA z/OS may also issue an alert. See *warning threshold*.

AMC. (1) Automation Manager Configuration (2) The Auto Msg Classes entry type

APF. Authorized program facility.

API. Application programming interface.

APPC. Advanced program-to-program communications.

application. An z/OS subsystem or job monitored by SA z/OS.

Application entry. A construct, created with the customization dialogs, used to represent and contain policy for an application.

application group. A named set of applications. An application group is part of an SA z/OS enterprise definition and is used for monitoring purposes.

ApplicationGroup entry. A construct, created with the customization dialogs, used to represent and contain policy for an application group.

application program. (1) A program written for or by a user that applies to the user's work, such as a program that does inventory or payroll. (2) A program used to connect and communicate with stations in a network, enabling users to perform application-oriented activities.

ARM. Automatic restart management.

ASCB. Address space control block.

ASCB status. An application status derived by SA z/OS running a routine (the ASCB checker) that searches the z/OS address space control blocks (ASCBs) for address spaces with a particular job name. The job name used by the ASCB checker is the job name defined in the customization dialog for the application.

ASCII (American National Standard Code for Information Interchange). The standard code, using a coded character set consisting of 7-bit coded characters

(8-bit including parity check), for information interchange among data processing systems, data communication systems, and associated equipment. The ASCII set consists of control characters and graphic characters. (A)

ASF. Automation status file.

authorized program facility (APF). A facility that permits identification of programs that are authorized to use restricted functions.

automated function. SA z/OS automated functions are automation operators, NetView autotasks that are assigned to perform specific automation functions. However, SA z/OS defines its own synonyms, or *automated function names*, for the NetView autotasks, and these function names are referred to in the sample policy databases provided by SA z/OS. For example, the automation operator AUTBASE corresponds to the SA z/OS automated function BASEOPER.

automated console operations (ACO). The concept (versus a product) of using computers to perform a large subset of tasks ordinarily performed by operators, or assisting operators in performing these tasks.

automatic restart management (ARM). A z/OS recovery function that improves the availability of specified subsystems and applications by automatically restarting them under certain circumstances. Automatic restart management is a function of the Cross-System Coupling Facility (XCF) component of z/OS.

automatic restart management element name. In MVS 5.2 or later, z/OS automatic restart management requires the specification of a unique sixteen character name for each address space that registers with it. All automatic restart management policy is defined in terms of the element name, including SA z/OS's interface with it.

automation. The automatic initiation of actions in response to detected conditions or events. SA z/OS provides automation for z/OS applications, z/OS components, and remote systems that run z/OS. SA z/OS also provides tools that can be used to develop additional automation.

automation agent. In SA z/OS, the automation function is split up between the automation manager and the automation agents. The observing, reacting and doing parts are located within the NetView address space, and are known as the *automation agents*. The automation agents are responsible for:

- recovery processing
- message processing
- active monitoring: they propagate status changes to the automation manager

automation configuration file. The data set that consists of:

- the automation control file (ACF)
- the automation manager configuration file (AMC)
- the NetView automation table (AT)
- the MPFLSTSA member

automation control file (ACF). In SA z/OS, a file that contains system-level automation policy information. There is one master automation control file for each NetView system on which SA z/OS is installed. Additional policy information and all resource status information is contained in the policy database (PDB). The SA z/OS customization dialogs must be used to build the automation control files. They must not be edited manually.

automation flags. In SA z/OS, the automation policy settings that determine the operator functions that are automated for a resource and the times during which automation is active. When SA z/OS is running, automation is controlled by automation flag policy settings and override settings (if any) entered by the operator. Automation flags are set using the customization dialogs.

automation manager. In SA z/OS, the automation function is split up between the automation manager and the automation agents. The coordination, decision making and controlling functions are processed by each sysplex's *automation manager*.

The automation manager contains a model of all of the automated resources within the sysplex. The automation agents feed the automation manager with status information and perform the actions that the automation manager tells them to.

The automation manager provides *sysplex-wide* automation.

Automation Manager Configuration. The Automation Manager Configuration file (AMC) contains an image of the automated systems in a sysplex or of a standalone system.

Automation NetView. In SA z/OS the NetView that performs routine operator tasks with command procedures or uses other ways of automating system and network management, issuing automatic responses to messages and management services units.

automation operator. NetView automation operators are NetView autotasks that are assigned to perform specific automation functions. See also *automated function*. NetView automation operators may receive messages and process automation procedures. There are no logged-on users associated with automation operators. Each automation operator is an operating system task and runs concurrently with other NetView tasks. An automation operator could be set up to handle JES2 messages that schedule automation procedures, and an automation statement could route such messages to the automation operator. Similar to

operator station task. SA z/OS message monitor tasks and target control tasks are automation operators.

automation policy. The policy information governing automation for individual systems. This includes automation for applications, z/OS subsystems, z/OS data sets, and z/OS components.

automation policy settings. The automation policy information contained in the automation control file. This information is entered using the customization dialogs. You can display or modify these settings using the customization dialogs.

automation procedure. A sequence of commands, packaged as a NetView command list or a command processor written in a high-level language. An automation procedure performs automation functions and runs under NetView.

automation status file. In SA z/OS, a file containing status information for each automated subsystem, component or data set. This information is used by SA z/OS automation when taking action or when determining what action to take. In Release 2 and above of AOC/MVS, status information is also maintained in the operational information base.

automation table (AT). See *NetView automation table*.

autotask. A NetView automation task that receives messages and processes automation procedures. There are no logged-on users associated with autotasks. Each autotask is an operating system task and runs concurrently with other NetView tasks. An autotask could be set up to handle JES2 messages that schedule automation procedures, and an automation statement could route such messages to the autotasks. Similar to *operator station task*. SA z/OS message monitor tasks and target control tasks are autotasks. Also called *automation operator*.

available. In VTAM programs, pertaining to a logical unit that is active, connected, enabled, and not at its session limit.

B

basic mode. A central processor mode that does not use logical partitioning. Contrast with *logically partitioned (LPAR) mode*.

BCP Internal Interface. Processor function of CMOS-390, zSeries processor families. It allows the communication between basic control programs such as z/OS and the processor support element in order to exchange information or to perform processor control functions. Programs using this function can perform hardware operations such as ACTIVATE or SYSTEM RESET.

beaconing. The repeated transmission of a frame or messages (beacon) by a console or workstation upon detection of a line break or outage.

BookManager. An IBM product that lets users view softcopy documents on their workstations.

C

central processor (CP). The part of the computer that contains the sequencing and processing facilities for instruction execution, initial program load (IPL), and other machine operations.

central processor complex (CPC). A physical collection of hardware that consists of central storage, one or more central processors, timers, and channels.

central site. In a distributed data processing network, the central site is usually defined as the focal point for alerts, application design, and remote system management tasks such as problem management.

CFR/CFS and ISC/ISR. I/O operations can display and return data about integrated system channels (ISC) connected to a coupling facility and coupling facility receiver (CFR) channels and coupling facility sender (CFS) channels.

channel. A path along which signals can be sent; for example, data channel, output channel. See also *link*.

channel path identifier. A system-unique value assigned to each channel path.

CHPID. In SA z/OS, channel path ID; the address of a channel.

CHPID port. A label that describes the system name, logical partitions, and channel paths.

channel-attached. (1) Attached directly by I/O channels to a host processor (for example, a channel-attached device). (2) Attached to a controlling unit by cables, rather than by telecommunication lines. Contrast with *link-attached*. Synonymous with *local*.

CI. Console integration.

CICS/VS. Customer Information Control System for Virtual Storage.

CLIST. Command list.

clone. A set of definitions for application instances that are derived from a basic application definition by substituting a number of different system-specific values into the basic definition.

clone ID. A generic means of handling system-specific values such as the MVS SYSC clone or the VTAM subarea number. Clone IDs can be substituted into

application definitions and commands to customize a basic application definition for the system that it is to be instantiated on.

CNC. A channel path that transfers data between a host system image and an ESCON control unit. It can be point-to-point or switchable.

command. A request for the performance of an operation or the execution of a particular program.

command facility. The component of NetView that is a base for command processors that can monitor, control, automate, and improve the operation of a network. The successor to NCCF.

command list (CLIST). (1) A list of commands and statements, written in the NetView command list language or the REXX language, designed to perform a specific function for the user. In its simplest form, a command list is a list of commands. More complex command lists incorporate variable substitution and conditional logic, making the command list more like a conventional program. Command lists are typically interpreted rather than being compiled. (2) In SA z/OS, REXX command lists that can be used for automation procedures.

command procedure. In NetView, either a command list or a command processor.

command processor. A module designed to perform a specific function. Command processors, which can be written in assembler or a high-level language (HLL), are issued as commands.

Command Tree/2. An OS/2-based program that helps you build commands on an OS/2 window, then routes the commands to the destination you specify (such as a 3270 session, a file, a command line, or an application program). It provides the capability for operators to build commands and route them to a specified destination.

common commands. The SA z/OS subset of the CPC operations management commands.

common routine. One of several SA z/OS programs that perform frequently used automation functions. Common routines can be used to create new automation procedures.

Common User Access (CUA) architecture. Guidelines for the dialog between a human and a workstation or terminal.

communication controller. A type of communication control unit whose operations are controlled by one or more programs stored and executed in the unit or by a program executed in a processor to which the controller is connected. It manages the details of line control and the routing of data through a network.

communication line. Deprecated term for *telecommunication line*.

connectivity view. In SA z/OS, a display that uses graphic images for I/O devices and lines to show how they are connected.

console automation. The process of having NetView facilities provide the console input usually handled by the operator.

console connection. In SA z/OS, the 3270 or ASCII (serial) connection between a PS/2 computer and a target system. Through this connection, the workstation appears (to the target system) to be a console.

console integration (CI). A hardware facility that if supported by an operating system, allows operating system messages to be transferred through an internal hardware interface for display on a system console. Conversely, it allows operating system commands entered at a system console to be transferred through an internal hardware interface to the operating system for processing.

consoles. Workstations and 3270-type devices that manage your enterprise.

Control units. Hardware units that control I/O operations for one or more devices. You can view information about control units through I/O operations, and can start or stop data going to them by blocking and unblocking ports.

controller. A unit that controls I/O operations for one or more devices.

couple data set. A data set that is created through the XCF couple data set format utility and, depending on its designated type, is shared by some or all of the z/OS systems in a sysplex. See also *sysplex couple data set* and *XCF couple data set*.

coupling facility. The hardware element that provides high-speed caching, list processing, and locking functions in a sysplex.

CP. Central processor.

CPC. Central processor complex.

CPC operations management commands. A set of commands and responses for controlling the operation of System/390 CPCs.

CPC subset. All or part of a CPC. It contains the minimum *resource* to support a single control program.

CPCB. Command processor control block; an I/O operations internal control block that contains information about the command being processed.

CPU. Central processing unit. Deprecated term for *processor*.

cross-system coupling facility (XCF). XCF is a component of z/OS that provides functions to support cooperation between authorized programs running within a sysplex.

CTC. The channel-to-channel (CTC) channel can communicate with a CTC on another host for intersystem communication.

Customer Information Control System (CICS). A general-purpose transactional program that controls online communication between terminal users and a database for a large number of end users on a real-time basis.

customization dialogs. The customization dialogs are an ISPF application. They are used to customize the enterprise policy, like, for example, the enterprise resources and the relationships between resources, or the automation policy for systems in the enterprise. How to use these dialogs is described in *IBM Tivoli System Automation for z/OS Customizing and Programming*.

CVC. A channel operating in converted (CVC) mode transfers data in blocks and a CBY channel path transfers data in bytes. Converted CVC or CBY channel paths can communicate with a parallel control unit. This resembles a point-to-point parallel path and dedicated connection, regardless whether it passes through a switch.

D

DASD. Direct access storage device.

data services task (DST). The NetView subtask that gathers, records, and manages data in a VSAM file or a network device that contains network management information.

data set. The major unit of data storage and retrieval, consisting of a collection of data in one of several prescribed arrangements and described by control information to which the system has access.

data set members. Members of partitioned data sets that are individually named elements of a larger file that can be retrieved by name.

DBCS. Double-byte character set.

DCCF. Disabled console communication facility.

DCF. Document composition facility.

DELAY Report. An RMF report that shows the activity of each job in the system and the hardware and software resources that are delaying each job.

Devices. You can see information about all devices (such as printers, tape or disk drives, displays, or

communications controllers) attached to a particular switch, and control paths and jobs to devices.

DEVR Report. An RMF report that presents information about the activity of I/O devices that are delaying jobs.

dialog. Interactive 3270 panels.

direct access storage device (DASD). A device in which the access time is effectively independent of the location of the data; for example, a disk.

disabled console communication facility (DCCF). A z/OS component that provides limited-function console communication during system recovery situations.

display. (1) To present information for viewing, usually on the screen of a workstation or on a hardcopy device. (2) Deprecated term for *panel*.

disk operating system (DOS). (1) An operating system for computer systems that use disks and diskettes for auxiliary storage of programs and data. (2) Software for a personal computer that controls the processing of programs. For the IBM Personal Computer, the full name is Personal Computer Disk Operating System (PCDOS).

distribution manager. The component of the NetView program that enables the host system to use, send, and delete files and programs in a network of computers.

domain. (1) An access method and its application programs, communication controllers, connecting lines, modems, and attached workstations. (2) In SNA, a system services control point (SSCP) and the physical units (PUs), logical units (LUs), links, link stations, and associated resources that the SSCP can control by means of activation requests and deactivation requests.

double-byte character set (DBCS). A character set, such as Kanji, in which each character is represented by a 2-byte code.

DP enterprise. Data processing enterprise.

DSIPARM. This file is a collection of members of NetView's customization.

DST. Data Services Task.

E

EBCDIC. Extended binary-coded decimal interchange code. A coded character set consisting of 8-bit coded characters.

ECB. Event control block. A control block used to represent the status of an event.

EMCS. Extended multiple console support.

enterprise. An organization, such as a business or a school, that uses data processing.

enterprise monitoring. Enterprise monitoring is used by SA z/OS to update the *NetView Management Console (NMC)* resource status information that is stored in the *Resource Object Data Manager (RODM)*. Resource status information is acquired by enterprise monitoring of the *Resource Measurement Facility (RMF) Monitor III* service information at user-defined intervals. SA z/OS stores this information in its operational information base, where it is used to update the information presented to the operator in graphic displays.

entries. Resources, such as processors, entered on panels.

entry type. Resources, such as processors or applications, used for automation and monitoring.

environment. Data processing enterprise.

error threshold. An automation policy setting that specifies when SA z/OS should stop trying to restart or recover an application, subsystem or component, or offload a data set.

ESA. Enterprise Systems Architecture.

eServer. Processor family group designator used by the SA z/OS customization dialogs to define a target hardware as member of the zSeries or 390-CMOS processor families.

event. (1) In NetView, a record indicating irregularities of operation in physical elements of a network. (2) An occurrence of significance to a task; for example, the completion of an asynchronous operation, such as an input/output operation. (3) Events are part of a trigger condition, in a way that if all events of a trigger condition have occurred, a *STARTUP* or *SHUTDOWN* of an application is performed.

exception condition. An occurrence on a system that is a deviation from normal operation. SA z/OS monitoring highlights exception conditions and allows an SA z/OS enterprise to be managed by exception.

extended recovery facility (XRF). A facility that minimizes the effect of failures in z/OS, VTAM, the host processor, or high availability applications during sessions between high availability applications and designated terminals. This facility provides an alternate subsystem to take over sessions from the failing subsystem.

F

fallback system. See *secondary system*.

field. A collection of bytes within a record that are logically related and are processed as a unit.

file manager commands. A set of SA z/OS commands that read data from or write data to the automation control file or the operational information base. These commands are useful in the development of automation that uses SA z/OS facilities.

focal point. In NetView, the focal-point domain is the central host domain. It is the central control point for any management services element containing control of the network management data.

focus host. A processor with the role in the context of a unified system image

focal point system. (1) A system that can administer, manage, or control one or more target systems. There are a number of different focal point system associated with IBM automation products. (2) **NMC focal point system.** The NMC focal point system is a NetView system with an attached workstation server and LAN that gathers information about the state of the network. This focal point system uses RODM to store the data it collects in the data model. The information stored in RODM can be accessed from any LAN-connected workstation with NetView Management Console installed. (3) **NPDA focal point system.** This is a NetView system that collects all the NPDA alerts that are generated within your enterprise. It is supported by NetView. If you have SA z/OS installed the NPDA focal point system must be the same as your NMC focal point system. The NPDA focal point system is also known as the *alert focal point system*. (4) **SA z/OS Processor Operations focal point system.** This is a NetView system that has SA z/OS host code installed. The SA z/OS Processor Operations focal point system receives messages from the systems and operator consoles of the machines that it controls. It provides full systems and operations console function for its target systems. It can be used to IPL these systems. Note that some restrictions apply to the Hardware Management Console for an S/390 microprocessor cluster. (5) **SA z/OS SDF focal point system.** The SA z/OS SDF focal point system is an SA z/OS NetView system that collects status information from other SA z/OS NetViews within your enterprise. (6) **Status focal point system.** In NetView, the system to which STATMON, VTAM and NLDM send status information on network resources. If you have a NMC focal point, it must be on the same system as the Status focal point. (7) **Hardware Management Console.** Although not listed as a focal point, the Hardware Management Console acts as a focal point for the console functions of an S/390 microprocessor cluster. Unlike all the other focal points in this definition, the Hardware Management Console runs on a LAN-connected workstation,

frame. For a System/390 microprocessor cluster, a frame contains one or two central processor complexes (CPCs), support elements, and AC power distribution.

full-screen mode. In NetView, a form of panel presentation that makes it possible to display the contents of an entire workstation screen at once. Full-screen mode can be used for fill-in-the-blanks prompting. Contrast with *line mode*.

G

gateway session. An NetView-NetView Task session with another system in which the SA z/OS outbound gateway operator logs onto the other NetView session without human operator intervention. Each end of a gateway session has both an inbound and outbound gateway operator.

generic alert. Encoded alert information that uses code points (defined by IBM and possibly customized by users or application programs) stored at an alert receiver, such as NetView.

generic routines. In SA z/OS, a set of self-contained automation routines that can be called from the NetView automation table, or from user-written automation procedures.

group. A collection of target systems defined through configuration dialogs. An installation might set up a group to refer to a physical site or an organizational or application entity.

group entry. A construct, created with the customization dialogs, used to represent and contain policy for a group.

group entry type. A collection of target systems defined through the customization dialog. An installation might set up a group to refer to a physical site or an organizational entity. Groups can, for example, be of type STANDARD or SYSPLEX.

H

Hardware Management Console. A console used by the operator to monitor and control a System/390 microprocessor cluster.

Hardware Management Console Application (HWMCA). A direct-manipulation object-oriented graphical user interface that provides single point of control and single system image for hardware elements. HWMCA provides customer grouping support, aggregated and real-time system status using colors, consolidated hardware messages support, consolidated operating system messages support, consolidated service support, and hardware commands targeted at a single system, multiple systems, or a customer group of systems.

heartbeat. In SA z/OS, a function that monitors the validity of the status forwarding path between remote systems and the NMC focal point, and monitors the

availability of remote z/OS systems, to ensure that status information displayed on the SA z/OS workstation is current.

help panel. An online panel that tells you how to use a command or another aspect of a product.

hierarchy. In the NetView program, the resource types, display types, and data types that make up the organization, or levels, in a network.

high-level language (HLL). A programming language that does not reflect the structure of any particular computer or operating system. For the NetView program, the high-level languages are PL/I and C.

HLL. High-level language.

host system. In a coupled system or distributed system environment, the system on which the facilities for centralized automation run. SA z/OS publications refer to target systems or focal-point systems instead of hosts.

host (primary processor). The processor at which you enter a command (also known as the *issuing processor*).

HWMCA. Hardware Management Console Application. Application for the graphic hardware management console that monitors and controls a central processor complex. It is attached to a target processor (a system 390 microprocessor cluster) as a dedicated system console. This microprocessor uses OCF to process commands.

I

images. A grouping of processors and I/O devices that you define. You can define a single-image mode that allows a multiprocessor system to function as one central processor image.

IMS/VS. Information Management System/Virtual Storage.

inbound. In SA z/OS, messages sent to the focal-point system from the PC or target system.

inbound gateway operator. The automation operator that receives incoming messages, commands, and responses from the outbound gateway operator at the sending system. The inbound gateway operator handles communications with other systems using a gateway session.

Information Management System/Virtual Storage (IMS/VS). A database/data communication (DB/DC) system that can manage complex databases and networks. Synonymous with IMS.

INGEIO PROC. The I/O operations default procedure name; part of the SYS1.PROCLIB.

initial program load (IPL). (1) The initialization procedure that causes an operating system to commence operation. (2) The process by which a configuration image is loaded into storage at the beginning of a workday or after a system malfunction. (3) The process of loading system programs and preparing a system to run jobs.

initialize automation. SA z/OS-provided automation that issues the correct z/OS start command for each subsystem when SA z/OS is initialized. The automation ensures that subsystems are started in the order specified in the automation control file and that prerequisite applications are functional.

input/output support processor (IOSP). The hardware unit that provides I/O support functions for the primary support processor and maintenance support functions for the processor controller.

Interactive System Productivity Facility (ISPF). An IBM licensed program that serves as a full-screen editor and dialog manager. Used for writing application programs, it provides a means of generating standard screen panels and interactive dialogs between the application programmer and the terminal user.

interested operator list. The list of operators who are to receive messages from a specific target system.

internal token. A *logical token* (LTOK); name by which the I/O resource or object is known; stored in IODF.

IOCDs. I/O configuration data set. The data set that describes the I/O configuration.

I/O Ops. I/O operations.

IOSP. Input/Output Support Processor.

I/O operations. The part of SA z/OS that provides you with a single point of logical control for managing connectivity in your active I/O configurations. I/O operations takes an active role in detecting unusual conditions and lets you view and change paths between a processor and an I/O device, using dynamic switching (the ESCON director). Also known as I/O Ops.

I/O resource number. Combination of channel path identifier (CHPID), device number, etc. See internal token.

IPL. Initial program load.

ISA. Industry Standard Architecture.

ISPF. Interactive System Productivity Facility.

ISPF console. From this 3270-type console you are logged onto ISPF to use the runtime panels for I/O operations and SA z/OS customization panels.

issuing host. See *primary host*; the base program at which you enter a command for processing.

J

JCL. Job control language.

JES. Job entry subsystem.

job. (1) A set of data that completely defines a unit of work for a computer. A job usually includes all necessary computer programs, linkages, files, and instructions to the operating system. (2) An address space.

job control language (JCL). A problem-oriented language designed to express statements in a job that are used to identify the job or describe its requirements to an operating system.

job entry subsystem (JES). A facility for spooling, job queuing, and managing I/O. In SA z/OS publications, JES refers to JES2 or JES3, unless distinguished as being either one or the other.

K

Kanji. An ideographic character set used in Japanese. See also *double-byte character set*.

L

LAN. Local area network.

line mode. A form of screen presentation in which the information is presented a line at a time in the message area of the terminal screen. Contrast with *full-screen mode*.

link. (1) In SNA, the combination of the link connection and the link stations joining network nodes; for example, a System/370 channel and its associated protocols, a serial-by-bit connection under the control of synchronous data link control (SDLC). (2) In SA z/OS, link connection is the physical medium of transmission.

link-attached. Describes devices that are physically connected by a telecommunication line. Contrast with *channel-attached*.

Linux for zSeries and S/390. UNIX-like open source operating system conceived by Linus Torvalds and developed across the internet.

local. Pertaining to a device accessed directly without use of a telecommunication line. Synonymous with *channel-attached*.

local area network (LAN). (1) A network in which a set of devices is connected for communication. They

can be connected to a larger network. See also *token ring*. (2) A network in which communications are limited to a moderately-sized geographic area such as a single office building, warehouse, or campus, and that do not generally extend across public rights-of-way.

logical partition (LP). A subset of the processor hardware that is defined to support an operating system. See also *logically partitioned (LPAR) mode*.

logical switch number (LSN). Assigned with the switch parameter of the CHPID macro of the IOCP.

logical token (LTOK). Resource number of an object in the IODF.

logical unit (LU). In SNA, a port through which an end user accesses the SNA network and the functions provided by system services control points (SSCPs). An LU can support at least two sessions — one with an SSCP and one with another LU — and may be capable of supporting many sessions with other LUs. See also *physical unit (PU)* and *system services control point (SSCP)*.

logical unit (LU) 6.2. A type of logical unit that supports general communications between programs in a distributed processing environment. LU 6.2 is characterized by (a) a peer relationship between session partners, (b) efficient use of a session for multiple transactions, (c) comprehensive end-to-end error processing, and (d) a generic application program interface (API) consisting of structured verbs that are mapped into a product implementation. Synonym for advanced program-to-program communications (APPC).

logically partitioned (LPAR) mode. A central processor mode that enables an operator to allocate system processor hardware resources among several logical partitions. Contrast with *basic mode*.

LOGR. The sysplex logger.

LP. Logical partition.

LPAR. Logically partitioned (mode).

LU. Logical unit.

LU-LU session. In SNA, a session between two logical units (LUs) in an SNA network. It provides communication between two end users, or between an end user and an LU services component.

LU 6.2. Logical unit 6.2.

LU 6.2 session. A session initiated by VTAM on behalf of an LU 6.2 application program, or a session initiated by a remote LU in which the application program specifies that VTAM is to control the session by using the APPCCMD macro.

M

MAT. Deprecated term for NetView Automation Table.

MCA. Micro Channel* architecture.

MCS. Multiple console support.

member. A specific function (one or more modules/routines) of a multisystem application that is defined to XCF and assigned to a group by the multisystem application. A member resides on one system in the sysplex and can use XCF services to communicate (send and receive data) with other members of the same group.

message automation table (MAT). Deprecated term for NetView Automation Table.

message class. A number that SA z/OS associates with a message to control routing of the message. During automated operations, the classes associated with each message issued by SA z/OS are compared to the classes assigned to each notification operator. Any operator with a class matching one of the message's classes receives the message.

message forwarding. The SA z/OS process of sending messages generated at an SA z/OS target system to the SA z/OS focal-point system.

message group. Several messages that are displayed together as a unit.

message monitor task. A task that starts and is associated with a number of communications tasks. Message monitor tasks receive inbound messages from a communications task, determine the originating target system, and route the messages to the appropriate target control tasks.

message processing facility (MPF). A z/OS table that screens all messages sent to the z/OS console. The MPF compares these messages with a customer-defined list of messages on which to automate, suppress from the z/OS console display, or both, and marks messages to automate or suppress. Messages are then broadcast on the subsystem interface (SSI).

message suppression. The ability to restrict the amount of message traffic displayed on the z/OS console.

Micro Channel architecture. The rules that define how subsystems and adapters use the Micro Channel bus in a computer. The architecture defines the services that each subsystem can or must provide.

microprocessor. A processor implemented on one or a small number of chips.

migration. Installation of a new version or release of a program to replace an earlier version or release.

MP. Multiprocessor.

MPF. Message processing facility.

MPFLSTSA. The MPFLST member that is built by SA z/OS.

Multiple Virtual Storage (MVS). An IBM licensed program. MVS, which is the predecessor of OS/390, is an operating system that controls the running of programs on a System/390 or System/370 processor. MVS includes an appropriate level of the Data Facility Product (DFP) and Multiple Virtual Storage/Enterprise Systems Architecture System Product Version 5 (MVS/ESA SP5).

multiprocessor (MP). A CPC that can be physically partitioned to form two operating processor complexes.

multisystem application. An application program that has various functions distributed across z/OS images in a multisystem environment.

multisystem environment. An environment in which two or more z/OS images reside in one or more processors, and programs on one image can communicate with programs on the other images.

MVS. Multiple Virtual Storage, predecessor of z/OS.

MVS image. A single occurrence of the MVS/ESA operating system that has the ability to process work.

MVS/JES2. Multiple Virtual Storage/Job Entry System 2. A z/OS subsystem that receives jobs into the system, converts them to internal format, selects them for execution, processes their output, and purges them from the system. In an installation with more than one processor, each JES2 processor independently controls its job input, scheduling, and output processing.

MVS/ESA. Multiple Virtual Storage/Enterprise Systems Architecture.

N

NAU. (1) Network accessible unit. (2) Network addressable unit.

NCCF. Network Communications Control Facility.

NCP. (1) Network Control Program (IBM licensed program). Its full name is Advanced Communications Function for the Network Control Program. Synonymous with *ACF/NCP*. (2) Network control program (general term).

NetView. An IBM licensed program used to monitor a network, manage it, and diagnose network problems. NetView consists of a command facility that includes a presentation service, command processors, automation based on command lists, and a transaction processing structure on which the session monitor, hardware

monitor, and terminal access facility (TAF) network management applications are built.

network accessible unit (NAU). A logical unit (LU), physical unit (PU), control point (CP), or system services control point (SSCP). It is the origin or the destination of information transmitted by the path control network. Synonymous with *network addressable unit*.

network addressable unit (NAU). Synonym for *network accessible unit*.

NetView automation procedures. A sequence of commands, packaged as a NetView command list or a command processor written in a high-level language. An automation procedure performs automation functions and runs under the NetView program.

NetView automation table (AT). A table against which the NetView program compares incoming messages. A match with an entry triggers the specified response. SA z/OS entries in the NetView automation table trigger an SA z/OS response to target system conditions. Formerly known as the message automation table (MAT).

NetView Command list language. An interpretive language unique to NetView that is used to write command lists.

NetView (NCCF) console. A 3270-type console for NetView commands and runtime panels for system operations and processor operations.

NetView Graphic Monitor Facility (NGMF). Deprecated term for NetView Management Console.

NetView hardware monitor. The component of NetView that helps identify network problems, such as hardware, software, and microcode, from a central control point using interactive display techniques. Formerly called *network problem determination application*.

NetView log. The log in which NetView records events pertaining to NetView and SA z/OS activities.

NetView message table. See *NetView automation table*.

NetView Management Console (NMC). A function of the NetView program that provides a graphic, topological presentation of a network that is controlled by the NetView program. It provides the operator different views of a network, multiple levels of graphical detail, and dynamic resource status of the network. This function consists of a series of graphic windows that allows you to manage the network interactively. Formerly known as the NetView Graphic Monitor Facility (NGMF).

NetView-NetView task (NNT). The task under which a cross-domain NetView operator session runs. Each

NetView program must have a NetView-NetView task to establish one NNT session. See also *operator station task*.

NetView-NetView Task session. A session between two NetView programs that runs under a NetView-NetView Task. In SA z/OS, NetView-NetView Task sessions are used for communication between focal point and remote systems.

NetView paths via logical unit (LU 6.2). A type of network-accessible port (VTAM connection) that enables end users to gain access to SNA network resources and communicate with each other. LU 6.2 permits communication between processor operations and the workstation.

network. (1) An interconnected group of nodes. (2) In data processing, a user application network. See *SNA network*.

Network Communications Control Facility (NCCF). The operations control facility for the network. NCCF consists of a presentation service, command processors, automation based on command lists, and a transaction processing structure on which the network management applications NLDM and NPDA are built. NCCF is a precursor to the NetView command facility.

Network Control Program (NCP). An IBM licensed program that provides communication controller support for single-domain, multiple-domain, and interconnected network capability. Its full name is Advanced Communications Function for the Network Control Program.

Networking NetView. In SA z/OS the NetView that performs network management functions, such as managing the configuration of a network. In SA z/OS it is common to also route alerts to the Networking NetView.

Network Problem Determination Application (NPDA). An NCCF application that helps you identify network problems, such as hardware, software, and microcode, from a central control point using interactive display methods. The alert manager for the network. The precursor of the NetView hardware monitor.

NGMF. Deprecated term for NetView Management Console.

NGMF focal-point system. Deprecated term for NMC focal point system.

NIP. Nucleus initialization program.

NMC focal point system. See *focal point system*

NMC workstation. The NMC workstation is the primary way to dynamically monitor SA z/OS systems. From the windows, you see messages, monitor

status, view trends, and react to changes before they cause problems for end users. You can use multiple windows to monitor multiple views of the system.

NNT. NetView-NetView task.

notification message. An SA z/OS message sent to a human notification operator to provide information about significant automation actions. Notification messages are defined using the customization dialogs.

notification operator. A NetView console operator who is authorized to receive SA z/OS notification messages. Authorization is made through the customization dialogs.

NPDA. Network Problem Determination Application.

NPDA focal-point system. See *focal-point system*.

NTRI. NCP/token-ring interconnection.

nucleus initialization program (NIP). The program that initializes the resident control program; it allows the operator to request last-minute changes to certain options specified during system generation.

O

objective value. An average Workflow or Using value that SA z/OS can calculate for applications from past service data. SA z/OS uses the objective value to calculate warning and alert thresholds when none are explicitly defined.

OCA. In SA z/OS, operator console A, the active operator console for a target system. Contrast with *OCB*.

OCB. In SA z/OS, operator console B, the backup operator console for a target system. Contrast with *OCA*.

OCF. Operations command facility.

OCF-based processor. A central processor complex that uses an operations command facility for interacting with human operators or external programs to perform operations management functions on the CPC.

OPC/A. Operations Planning and Control/Advanced.

OPC/ESA. Operations Planning and Control/Enterprise Systems Architecture.

operating system (OS). Software that controls the execution of programs and that may provide services such as resource allocation, scheduling, input/output control, and data management. Although operating systems are predominantly software, partial hardware implementations are possible. (T)

operations. The real-time control of a hardware device or software function.

operations command facility (OCF). A facility of the central processor complex that accepts and processes operations management commands.

Operations Planning and Control/Advanced (OPC/A). A set of IBM licensed programs that automate, plan, and control batch workload. OPC/A analyzes system and workload status and submits jobs accordingly.

Operations Planning and Control/ESA (OPC/ESA). A set of IBM licensed programs that automate, plan, and control batch workload. OPC/ESA analyzes system and workload status and submits jobs accordingly. The successor to OPC/A.

operator. (1) A person who keeps a system running. (2) A person or program responsible for managing activities controlled by a given piece of software such as z/OS, the NetView program, or IMS. (3) A person who operates a device. (4) In a language statement, the lexical entity that indicates the action to be performed on operands.

operator console. (1) A functional unit containing devices that are used for communications between a computer operator and a computer. (T) (2) A display console used for communication between the operator and the system, used primarily to specify information concerning application programs and I/O operations and to monitor system operation. (3) In SA z/OS, a console that displays output from and sends input to the operating system (z/OS, LINUX, VM, VSE). Also called *operating system console*. In the SA z/OS operator commands and configuration dialogs, OC is used to designate a target system operator console.

operator station task (OST). The NetView task that establishes and maintains the online session with the network operator. There is one operator station task for each network operator who logs on to the NetView program.

operator view. A set of group, system, and resource definitions that are associated together for monitoring purposes. An operator view appears as a graphic display in the graphical interface showing the status of the defined groups, systems, and resources.

OperatorView entry. A construct, created with the customization dialogs, used to represent and contain policy for an operator view.

OS. Operating system.

z/OS component. A part of z/OS that performs a specific z/OS function. In SA z/OS, component refers to entities that are managed by SA z/OS automation.

z/OS subsystem. Software products that augment the z/OS operating system. JES and TSO/E are examples of z/OS subsystems. SA z/OS includes automation for some z/OS subsystems.

z/OS system. A z/OS image together with its associated hardware, which collectively are often referred to simply as a system, or z/OS system.

OSA. I/O operations can display the open system adapter (OSA) channel logical definition, physical attachment, and status. You can configure an OSA channel on or off.

OST. Operator station task.

outbound. In SA z/OS, messages or commands from the focal-point system to the target system.

outbound gateway operator. The automation operator that establishes connections to other systems. The outbound gateway operator handles communications with other systems through a gateway session. The automation operator sends messages, commands, and responses to the inbound gateway operator at the receiving system.

P

page. (1) The portion of a panel that is shown on a display surface at one time. (2) To transfer instructions, data, or both between real storage and external page or auxiliary storage.

panel. (1) A formatted display of information that appears on a terminal screen. Panels are full-screen 3270-type displays with a monospaced font, limited color and graphics. (2) By using SA z/OS panels you can see status, type commands on a command line using a keyboard, configure your system, and passthru to other consoles. See also *help panel*. (3) In computer graphics, a display image that defines the locations and characteristics of display fields on a display surface. Contrast with *screen*.

parallel channels. Parallel channels operate in either byte (BY) or block (BL) mode. You can change connectivity to a parallel channel operating in block mode.

parameter. (1) A variable that is given a constant value for a specified application and that may denote the application. (2) An item in a menu for which the user specifies a value or for which the system provides a value when the menu is interpreted. (3) Data passed to a program or procedure by a user or another program, namely as an operand in a language statement, as an item in a menu, or as a shared data structure.

partition. (1) A fixed-size division of storage. (2) In VSE, a division of the virtual address area that is available for program processing. (3) On an IBM

Personal Computer fixed disk, one of four possible storage areas of variable size; one can be accessed by DOS, and each of the others may be assigned to another operating system.

partitionable CPC. A CPC that can be divided into 2 independent CPCs. See also *physical partition*, *single-image mode*, *MP*, *side*.

partitioned data set (PDS). A data set in direct access storage that is divided into partitions, called *members*, each of which can contain a program, part of a program, or data.

passive monitoring. In SA z/OS, the receiving of unsolicited messages from z/OS systems and their resources. These messages can prompt updates to resource status displays. See also *active monitoring*.

PCE. Processor controller. Also known as the “support processor” or “service processor” in some processor families.

PDB. Policy Database

PDS. Partitioned data set.

physical partition. Part of a CPC that operates as a CPC in its own right, with its own copy of the operating system.

physical unit (PU). In SNA, the component that manages and monitors the resources (such as attached links and adjacent link stations) of a node, as requested by a system services control point (SSCP) through an SSCP-PU session. An SSCP activates a session with the physical unit to indirectly manage, through the PU, resources of the node such as attached links.

physically partitioned (PP) configuration. A mode of operation that allows a multiprocessor (MP) system to function as two or more independent CPCs having separate power, water, and maintenance boundaries. Contrast with *single-image (SI) configuration*.

POI. Program operator interface.

policy. The automation and monitoring specifications for an SA z/OS enterprise. See *IBM Tivoli System Automation for z/OS Defining Automation Policy*.

policy database. The database where the automation policy is recorded. Also known as the PDB.

POR. Power-on reset.

port. (1) System hardware to which the I/O devices are attached. (2) On an ESCON switch, a port is an addressable connection. The switch routes data through the ports to the channel or control unit. Each port has a name that can be entered into a switch matrix, and you can use commands to change the switch configuration. (3) An access point (for example, a logical unit) for data entry or exit. (4) A functional unit of a node through

which data can enter or leave a data network. (5) In data communication, that part of a data processor that is dedicated to a single data channel for the purpose of receiving data from or transmitting data to one or more external, remote devices. (6) power-on reset (POR) (7) A function that re-initializes all the hardware in a CPC and loads the internal code that enables the CPC to load and run an operating system.

PP. Physically partitioned (configuration).

PPT. Primary POI task.

primary host. The base program at which you enter a command for processing.

primary POI task (PPT). The NetView subtask that processes all unsolicited messages received from the VTAM program operator interface (POI) and delivers them to the controlling operator or to the command processor. The PPT also processes the initial command specified to execute when NetView is initialized and timer request commands scheduled to execute under the PPT.

primary system. A system is a primary system for an application if the application is normally meant to be running there. SA z/OS starts the application on all the primary systems defined for it.

problem determination. The process of determining the source of a problem; for example, a program component, machine failure, telecommunication facilities, user or contractor-installed programs or equipment, environment failure such as a power loss, or user error.

processor controller. Hardware that provides support and diagnostic functions for the central processors.

processor operations. The part of SA z/OS that monitors and controls processor (hardware) operations. Processor operations provides a connection from a focal-point system to a target system. Through NetView on the focal-point system, processor operations automates operator and system consoles for monitoring and recovering target systems. Also known as ProcOps.

processor operations control file. Named by your system programmer, this file contains configuration and customization information. The programmer records the name of this control file in the processor operations file generation panel ISQDPG01.

Processor Resource/Systems Manager (PR/SM). The feature that allows the processor to use several operating system images simultaneously and provides logical partitioning capability. See also *LPAR*.

ProcOps. Processor operations.

ProcOps Service Machine (PSM). The PSM is a CMS user on a VM host system. It runs a CMS multitasking

application that serves as "virtual hardware" for ProcOps. ProcOps communicates via the PSM with the VM guest systems that are defined as target systems within ProcOps.

product automation. Automation integrated into the base of SA z/OS for the products DB2, CICS, IMS, OPC (formerly called *features*).

program to program interface (PPI). A NetView function that allows user programs to send or receive data buffers from other user programs and to send alerts to the NetView hardware monitor from system and application programs.

protocol. In SNA, the meanings of, and the sequencing rules for, requests and responses used for managing the network, transferring data, and synchronizing the states of network components.

proxy resource. A resource defined like an entry type APL representing a processor operations target system.

PR/SM. Processor Resource/Systems Manager.

PSM. ProcOps Service Machine.

PU. Physical unit.

R

remote system. A system that receives resource status information from an SA z/OS focal-point system. An SA z/OS remote system is defined as part of the same SA z/OS enterprise as the SA z/OS focal-point system to which it is related.

requester. A requester is a workstation software, which enables users to log on to a domain, that is, to the server(s) belonging to this domain, and use the resources in this domain. After the log on to a domain, users can access the shared resources and use the processing capability of the server(s). Because the bigger part of shared resources is on the server(s), users can reduce hardware investment.

resource. (1) Any facility of the computing system or operating system required by a job or task, and including main storage, input/output devices, the processing unit, data sets, and control or processing programs. (2) In NetView, any hardware or software that provides function to the network. (3) In SA z/OS, any z/OS application, z/OS component, job, device, or target system capable of being monitored or automated through SA z/OS.

Resource Access Control Facility (RACF). A program that can provide data security for all your resources. RACF protects data from accidental or deliberate unauthorized disclosure, modification, or destruction.

resource group. A physically partitionable portion of a processor. Also known as a *side*.

Resource Monitoring Facility (RMF) Monitor III. A program that measures and reports on the availability and activity of system hardware and software resources, such as processors, devices, storage, and address spaces. RMF can issue online reports about system performance problems as they occur.

Resource Object Data Manager (RODM). A data cache manager designed to support process control and automation applications. RODM provides an in-memory data cache for maintaining real-time data in an address space that is accessible by multiple applications. RODM also allows an application to query an object and receive a rapid response and act on it.

resource token. A unique internal identifier of an ESCON resource or resource number of the object in the IODF.

restart automation. SA z/OS-provided automation that monitors subsystems to ensure that they are running. If a subsystem fails, SA z/OS attempts to restart it according to the policy in the automation control file.

Restructured Extended Executor (REXX). An interpretive language used to write command lists.

return code. A code returned from a program used to influence the issuing of subsequent instructions.

REXX. Restructured Extended Executor.

REXX procedure. A command list written with the Restructured Extended Executor (REXX), which is an interpretive language.

RMF. Resource Measurement Facility.

RODM. Resource Object Data Manager.

S

SAF. Security Authorization Facility.

SA IOM. System Automation for Integrated Operations Management

SA z/OS. System Automation for z/OS

SA z/OS customization dialogs. An ISPF application through which the SA z/OS policy administrator defines policy for individual z/OS systems and builds automation control data and RODM load function files.

SA z/OS customization focal point system. See *focal point system*.

SA z/OS data model. The set of objects, classes and entity relationships necessary to support the function of SA z/OS and the NetView automation platform.

SA z/OS enterprise. The group of systems and resources defined in the customization dialogs under one enterprise name. An SA z/OS enterprise consists of connected z/OS systems running SA z/OS.

SA z/OS focal point system. See *focal point system*.

SA z/OS policy. The description of the systems and resources that make up an SA z/OS enterprise, together with their monitoring and automation definitions.

SA z/OS policy administrator. The member of the operations staff who is responsible for defining SA z/OS policy.

SA z/OS satellite. If you are running two NetViews on an z/OS system to split the automation and networking functions of NetView, it is common to route alerts to the Networking NetView. For SA z/OS to process alerts properly on the Networking NetView, you must install a subset of SA z/OS code, called an *SA z/OS satellite* on the Networking NetView.

SA z/OS SDF focal point system. See *focal point system*.

SCA. In SA z/OS, system console A, the active system console for a target hardware. Contrast with *SCB*.

SCB. In SA z/OS, system console B, the backup system console for a target hardware. Contrast with *SCA*.

screen. Deprecated term for display panel.

screen handler. In SA z/OS, software that interprets all data to and from a full-screen image of a target system. The interpretation depends on the format of the data on the full-screen image. Every processor and operating system has its own format for the full-screen image. A screen handler controls one PS/2 connection to a target system.

SDF. Status Display Facility.

SDLC. Synchronous data link control.

SDSF. System Display and Search Facility.

secondary system. A system is a secondary system for an application if it is defined to automation on that system, but the application is not normally meant to be running there. Secondary systems are systems to which an application can be moved in the event that one or more of its primary systems are unavailable. SA z/OS does not start the application on its secondary systems.

server. A server is a workstation that shares resources, which include directories, printers, serial devices, and computing powers.

service language command (SLC). The line-oriented command language of processor controllers or service processors.

service processor (SVP). The name given to a processor controller on smaller System/370 processors.

service period. Service periods allow the users to schedule the availability of applications. A service period is a set of time intervals (service windows), during which an application should be active.

service threshold. An SA z/OS policy setting that determines when to notify the operator of deteriorating service for a resource. See also *alert threshold* and *warning threshold*.

session. In SNA, a logical connection between two network addressable units (NAUs) that can be activated, tailored to provide various protocols, and deactivated, as requested. Each session is uniquely identified in a transmission header by a pair of network addresses identifying the origin and destination NAUs of any transmissions exchanged during the session.

session monitor. The component of the NetView program that collects and correlates session-related data and provides online access to this information. The successor to NLDM.

shutdown automation. SA z/OS-provided automation that manages the shutdown process for subsystems by issuing shutdown commands and responding to prompts for additional information.

side. A part of a partitionable CPC that can run as a physical partition and is typically referred to as the A-side or the B-side.

Simple Network Management Protocol (SNMP). An IP based industry standard protocol to monitor and control resources in an IP network.

single image. A processor system capable of being physically partitioned that has not been physically partitioned. Single-image systems can be target hardware processors.

single-image (SI) mode. A mode of operation for a multiprocessor (MP) system that allows it to function as one CPC. By definition, a uniprocessor (UP) operates in single-image mode. Contrast with *physically partitioned (PP) configuration*.

SLC. Service language command.

SMP/E. System Modification Program Extended.

SNA. Systems Network Architecture.

SNA network. In SNA, the part of a user-application network that conforms to the formats and protocols of systems network architecture. It enables reliable

transfer of data among end users and provides protocols for controlling the resources of various network configurations. The SNA network consists of network addressable units (NAUs), boundary function components, and the path control network.

SNMP. Simple Network Management Protocol (a TCP/IP protocol). A protocol that allows network management by elements, such as gateways, routers, and hosts. This protocol provides a means of communication between network elements regarding network resources.

solicited message. An SA z/OS message that directly responds to a command. Contrast with *unsolicited message*.

SSCP. System services control point.

SSI. Subsystem interface.

start automation. SA z/OS-provided automation that manages and completes the startup process for subsystems. During this process, SA z/OS replies to prompts for additional information, ensures that the startup process completes within specified time limits, notifies the operator of problems, if necessary, and brings subsystems to an UP (or ready) state.

startup. The point in time at which a subsystem or application is started.

status. The measure of the condition or availability of the resource.

status focal-point system. See *focal-point system*.

status display facility (SDF). The system operations part of SA z/OS that displays status of resources such as applications, gateways, and write-to-operator messages (WTORs) on dynamic color-coded panels. SDF shows spool usage problems and resource data from multiple systems.

steady state automation. The routine monitoring, both for presence and performance, of subsystems, applications, volumes and systems. Steady state automation may respond to messages, performance exceptions and discrepancies between its model of the system and reality.

structure. A construct used by z/OS to map and manage storage on a coupling facility. See cache structure, list structure, and lock structure.

subgroup. A named set of systems. A subgroup is part of an SA z/OS enterprise definition and is used for monitoring purposes.

SubGroup entry. A construct, created with the customization dialogs, used to represent and contain policy for a subgroup.

subplex. Situations where the physical sysplex has been divided into subentities, for example, a test sysplex and a production sysplex. This may be done to isolate the test environment from the production environment.

subsystem. (1) A secondary or subordinate system, usually capable of operating independent of, or asynchronously with, a controlling system. (2) In SA z/OS, an z/OS application or subsystem defined to SA z/OS.

subsystem interface. The z/OS interface over which all messages sent to the z/OS console are broadcast.

support element. A hardware unit that provides communications, monitoring, and diagnostic functions to a central processor complex (CPC).

support processor. Another name given to a processor controller on smaller System/370 processors; see *service processor*.

SVP. Service processor.

switches. ESCON directors are electronic units with ports that dynamically switch to route data to I/O devices. The switches are controlled by I/O operations commands that you enter on a workstation.

switch identifier. The switch device number (swchdevn), the logical switch number (LSN) and the switch name

symbolic destination name (SDN). Used locally at the workstation to relate to the VTAM application name.

synchronous data link control (SDLC). A discipline for managing synchronous, code-transparent, serial-by-bit information transfer over a link connection. Transmission exchanges may be duplex or half-duplex over switched or nonswitched links. The configuration of the link connection may be point-to-point, multipoint, or loop. SDLC conforms to subsets of the Advanced Data Communication Control Procedures (ADCCP) of the American National Standards Institute and High-Level Data Link Control (HDLC) of the International Standards Organization.

SYSINFO Report. An RMF report that presents an overview of the system, its workload, and the total number of jobs using resources or delayed for resources.

SysOps. System operations.

sysplex. A set of z/OS systems communicating and cooperating with each other through certain multisystem hardware components (coupling devices and timers) and software services (couple data sets).

In a sysplex, z/OS provides the coupling services that handle the messages, data, and status for the parts of a multisystem application that has its workload spread

across two or more of the connected processors, sysplex timers, coupling facilities, and couple data sets (which contains policy and states for automation).

A Parallel Sysplex is a sysplex that includes a coupling facility.

sysplex application group. A sysplex application group is a grouping of applications that can run on any system in a sysplex.

sysplex couple data set. A couple data set that contains sysplex-wide data about systems, groups, and members that use XCF services. All z/OS systems in a sysplex must have connectivity to the sysplex couple data set. See also *couple data set*.

Sysplex Timer. An IBM unit that synchronizes the time-of-day (TOD) clocks in multiple processors or processor sides. External Time Reference (ETR) is the z/OS generic name for the IBM Sysplex Timer (9037).

system. In SA z/OS, system means a focal point system (z/OS) or a target system (MVS, VM, VSE, LINUX, or CF).

System Automation for Integrated Operations

Management. (1) An outboard automation solution for secure remote access to mainframe/distributed systems. Tivoli System Automation for Integrated Operations Management, previously Tivoli AF/REMOTE, allows users to manage mainframe and distributed systems from any location. (2) The full name for SA IOM.

System Automation for OS/390. The full name for SA OS/390, the predecessor to System Automation for z/OS.

System Automation for z/OS. The full name for SA z/OS.

system console. (1) A console, usually having a keyboard and a display screen, that is used by an operator to control and communicate with a system. (2) A logical device used for the operation and control of hardware functions (for example, IPL, alter/display, and reconfiguration). The system console can be assigned to any of the physical displays attached to a processor controller or support processor. (3) In SA z/OS, the hardware system console for processor controllers or service processors of processors connected using SA z/OS. In the SA z/OS operator commands and configuration dialogs, SC is used to designate the system console for a target hardware processor.

System Display and Search Facility (SDSF). An IBM licensed program that provides information about jobs, queues, and printers running under JES2 on a series of panels. Under SA z/OS you can select SDSF from a pull-down menu to see the resources' status, view the z/OS system log, see WTOR messages, and see active jobs on the system.

System entry. A construct, created with the customization dialogs, used to represent and contain policy for a system.

System Modification Program/Extended (SMP/E). An IBM licensed program that facilitates the process of installing and servicing an z/OS system.

system operations. The part of SA z/OS that monitors and controls system operations applications and subsystems such as NetView, SDSF, JES, RMF, TSO, RODM, ACF/VTAM, CICS, IMS, and OPC. Also known as SysOps.

system services control point (SSCP). In SNA, the focal point within an SNA network for managing the configuration, coordinating network operator and problem determination requests, and providing directory support and other session services for end users of the network. Multiple SSCPs, cooperating as peers, can divide the network into domains of control, with each SSCP having a hierarchical control relationship to the physical units and logical units within its domain.

Systems Network Architecture (SNA). The description of the logical structure, formats, protocols, and operational sequences for transmitting information units through, and controlling the configuration and operation of, networks.

System/390 microprocessor cluster. A configuration that consists of central processor complexes (CPCs) and may have one or more integrated coupling facilities.

T

TAF. Terminal access facility.

target. A processor or system monitored and controlled by a focal-point system.

target control task. In SA z/OS, target control tasks process commands and send data to target systems and workstations through communications tasks. A target control task (a NetView autotask) is assigned to a target system when the target system is initialized.

target hardware. In SA z/OS, the physical hardware on which a target system runs. It can be a single-image or physically partitioned processor. Contrast with *target system*.

target system. (1) In a distributed system environment, a system that is monitored and controlled by the focal-point system. Multiple target systems can be controlled by a single focal-point system. (2) In SA z/OS, a computer system attached to the focal-point system for monitoring and control. The definition of a target system includes how remote sessions are established, what hardware is used, and what operating system is used.

task. (1) A basic unit of work to be accomplished by a computer. (2) In the NetView environment, an operator station task (logged-on operator), automation operator (autotask), application task, or user task. A NetView task performs work in the NetView environment. All SA z/OS tasks are NetView tasks. See also *communications task*, *message monitor task*, and *target control task*.

telecommunication line. Any physical medium, such as a wire or microwave beam, that is used to transmit data.

terminal access facility (TAF). (1) A NetView function that allows you to log onto multiple applications either on your system or other systems. You can define TAF sessions in the SA z/OS customization panels so you don't have to set them up each time you want to use them. (2) In NetView, a facility that allows a network operator to control a number of subsystems. In a full-screen or operator control session, operators can control any combination of subsystems simultaneously.

terminal emulation. The capability of a microcomputer or personal computer to operate as if it were a particular type of terminal linked to a processing unit to access data.

threshold. A value that determines the point at which SA z/OS automation performs a predefined action. See *alert threshold*, *warning threshold*, and *error threshold*.

time of day (TOD). Typically refers to the time-of-day clock.

Time Sharing Option (TSO). An optional configuration of the operating system that provides conversational time sharing from remote stations. It is an interactive service on z/OS, MVS/ESA, and MVS/XA.

Time-Sharing Option/Extended (TSO/E). An option of z/OS that provides conversational timesharing from remote terminals. TSO/E allows a wide variety of users to perform many different kinds of tasks. It can handle short-running applications that use fewer sources as well as long-running applications that require large amounts of resources.

timers. A NetView command that issues a command or command processor (list of commands) at a specified time or time interval.

TOD. Time of day.

token ring. A network with a ring topology that passes tokens from one attaching device to another; for example, the IBM Token-Ring Network product.

TP. Transaction program.

transaction program. In the VTAM program, a program that performs services related to the

processing of a transaction. One or more transaction programs may operate within a VTAM application program that is using the VTAM application program interface (API). In that situation, the transaction program would request services from the applications program using protocols defined by that application program. The application program, in turn, could request services from the VTAM program by issuing the APPCCMD macro instruction.

transitional automation. The actions involved in starting and stopping subsystems and applications that have been defined to SA z/OS. This can include issuing commands and responding to messages.

translating host. Role played by a host that turns a resource number into a token during a unification process.

trigger. Triggers, in combination with events and service periods, are used to control the starting and stopping of applications in a single system or a parallel sysplex.

TSO. Time Sharing Option.

TSO console. From this 3270-type console you are logged onto TSO or ISPF to use the runtime panels for I/O operations and SA z/OS customization panels.

TSO/E. TSO Extensions.

U

UCB. The unit control block; an MVS/ESA data area that represents a device and that is used for allocating devices and controlling I/O operations.

unsolicited message. An SA z/OS message that is not a direct response to a command. Contrast with *solicited message*.

user task. An application of the NetView program defined in a NetView TASK definition statement.

Using. An RMF Monitor III definition. Jobs getting service from hardware resources (processors or devices) are **using** these resources. The use of a resource by an address space can vary from 0% to 100% where 0% indicates no use during a Range period, and 100% indicates that the address space was found using the resource in every sample during that period. See also *Workflow*.

V

view. In the NetView Graphic Monitor Facility, a graphical picture of a network or part of a network. A view consists of nodes connected by links and may also include text and background lines. A view can be displayed, edited, and monitored for status information about network resources.

Virtual Storage Extended (VSE). An IBM licensed program whose full name is Virtual Storage Extended/Advanced Function. It is an operating system that controls the execution of programs.

Virtual Telecommunications Access Method (VTAM). An IBM licensed program that controls communication and the flow of data in an SNA network. It provides single-domain, multiple-domain, and interconnected network capability. Its full name is Advanced Communications Function for the Virtual Telecommunications Access Method. Synonymous with *ACF/VTAM*.

VM/ESA. Virtual Machine/Enterprise Systems Architecture.

VM Second Level Systems Support. With this function, Processor Operations is able to control VM second level systems (VM guest systems) in the same way that it controls systems running on real hardware.

volume. A direct access storage device (DASD) volume or a tape volume that serves a system in an SA z/OS enterprise.

volume entry. A construct, created with the customization dialogs, used to represent and contain policy for a volume.

volume group. A named set of volumes. A volume group is part of a system definition and is used for monitoring purposes.

volume group entry. A construct, created with the customization dialogs, used to represent and contain policy for a volume group.

Volume Workflow. The SA z/OS Volume Workflow variable is derived from the RMF Resource Workflow definition, and is used to measure the performance of volumes. SA z/OS calculates Volume Workflow using:

$$\text{Volume Workflow \%} = \frac{\text{accumulated Using}}{\text{accumulated Using} + \text{accumulated Delay}} * 100$$

The definition of **Using** is the percentage of time when a job has had a request accepted by a channel for the volume, but the request is not yet complete.

The definition of **Delay** is the delay that waiting jobs experience because of contention for the volume. See also *Address Space Workflow*.

VSE. Virtual Storage Extended.

VTAM. Virtual Telecommunications Access Method.

W

warning threshold. An application or volume service value that determines the level at which SA z/OS changes the associated icon in the graphical interface to the warning color. See *alert threshold*.

workflow. See *Address Space Workflow* and *Volume Workflow*.

workstation. In SA z/OS workstation means the *graphic workstation* that an operator uses for day-to-day operations.

write-to-operator (WTO). A request to send a message to an operator at the z/OS operator console. This request is made by an application and is handled by the WTO processor, which is part of the z/OS supervisor program.

write-to-operator-with-reply (WTOR). A request to send a message to an operator at the z/OS operator console that requires a response from the operator. This request is made by an application and is handled by the WTO processor, which is part of the z/OS supervisor program.

WTO. Write-to-Operator.

WTOR. Write-to-Operator-with-Reply.

WWV. The US National Institute of Standards and Technology (NIST) radio station that provides standard time information. A second station, known as WWVB, provides standard time information at a different frequency.

X

XCF. Cross-system coupling facility.

XCF couple data set. The name for the sysplex couple data set prior to MVS/ESA System Product Version 5 Release 1. See also *sysplex couple data set*.

XCF group. A set of related members that a multisystem application defines to XCF. A member is a specific function, or instance, of the application. A member resides on one system and can communicate with other members of the same group across the sysplex.

XRF. Extended recovery facility.

Numerics

390-CMOS. Processor family group designator used in the SA z/OS processor operations documentation and in the online help to identify any of the following S/390 CMOS processor machine types: 9672, 9674, 2003, 3000, or 7060. SA z/OS processor operations uses the

OCF facility of these processors to perform operations management functions. See *OCF-based processor*.

Index

Special characters

&APPLPARMS
ACFCMD common routine 15
ACFREP common routine 29
&COMPAPPL; variable 261
&DCOMP variable 261
&QCOMP variable 261
&RESAPPL variable 261

Numerics

256-character allow or prohibit
string 236, 238

A

accessibility xi
ACF file manager command 7
ACFCMD common routine 12
ACFFQRY file manager command 20
ACFREP common routine 26
active message handler 101
ACTIVMSG generic routine 101
address space management
INGRCLUP command 82
allow or prohibit attributes 238
defining 236, 241
AOCFILT generic routine 104
AOCGETCN common routine 33
AOCMSG common routine 34
AOCQRES common routine 40
AOCQRY common routine 41
AOCQRY task global variables 44
AOCUPDT common routine 52
AOFADMON common routine 93
AOFAJMON common routine
See INGPJMON common routine 97
AOFAPMON common routine 94
AOFATMON common routine 94
AOFPCMSG generic routine 105
AOFPCSM common routine 95
AOFEXCMD common routine 56
AOFNCMON common routine 95
AOFPCCHILD.0 task global variable 60
AOFPCCHILD.n task global variable 61
AOFRACON system utility 133
AOFSET common routine 57
AOFSHUTMOD global variable 90, 91
AOFSTREE 273
AOFSTREE common routine 58
AOFUXMON common routine 96
API
assembler language CALLS 254
description 173
with REXX 249
ASF file manager command 62
ASFUSER file manager command 67
automation control file
issuing commands from 12
automation control file WARM start 8

automation manager commands
INGPOST 78
INGRRCMD 83
Automation Table Function
ING\$QRY 167
AUTOTYPE task global variable 48

C

cascaded switch
FICON 175
CDEMATCH common routine 70
CHKSUBS common routine 73
CHKTHRES common routine 73
CMDCNTHI task global variable 15
code matching 70
commands
ACF 7
ACFCMD 12
ACFFQRY 20
ACFREP 26
AOCGETCN 33
AOCMSG 34
AOCQRES 40
AOCQRY 41
AOCUPDT 52
AOFADMON 93
AOFAPMON 94
AOFATMON 94
AOFPCMSG 105
AOFPCSM 95
AOFEXCMD 56
AOFNCMON 95
AOFSET 57
AOFSTREE 58
AOFUXMON 96
ASF 62
ASFUSER 67
CDEMATCH 70
CHKSUBS 73
CHKTHRES 73
DELETE FILE 189
INGCNTL 76
INGPJMOM 97
INGPOST 78
INGPSMON 98
INGQRY 81
INGRCLUP 82
INGRRCMD 83
INGSIT 150
INGSTOBS 153
INGSTX 155
INGTIMER 159
INGUSS 83
INGVARS 162
INGVMON 99
INGVSTOP 88
INGVSTRT 87
INGVTAM 164
ISQMTSYS 100
MDFYSHUT 90

commands (*continued*)

QUERY ENTITY CHP 189
QUERY ENTITY CNTLUNIT 195
QUERY ENTITY DEV 198
QUERY ENTITY HOST 200
QUERY ENTITY SWITCH 203
QUERY FILE 206
QUERY INTERFACE
CNTLUNIT 207
QUERY INTERFACE SWITCH 212
QUERY RELATION CHP 219
QUERY RELATION CNTLUNIT 220
QUERY RELATION DEV 220
QUERY RELATION HOST 221
QUERY RELATION SWITCH 222
QUERY SWITCH 223
REMOVE CHP 226
REMOVE DEV 229
RESTORE CHP 226
RESTORE DEV 229
WRITEFILE 235
WRITEPORT 236
WRITESWCH 241
common routines
ACF 7
ACFCMD 12
ACFFQRY 20
ACFREP 26
AOCGETCN 33
AOCMSG 34
AOCQRES 40
AOCQRY 41
AOCUPDT 52
AOFADMON 93
AOFAPMON 94
AOFATMON 94
AOFPCSM 95
AOFEXCMD 56
AOFNCMON 95
AOFSET 57
AOFSTREE 58
AOFUXMON 96
ASF 62
ASFUSER 67
CDEMATCH 70
CHKSUBS 73
CHKTHRES 73
INGPJMOM 97
INGPOST 78
INGPSMON 98
INGVMON 99
ISQMTSYS 100
MDFYSHUT 90
communication mask 236, 238
connectivity
defining 236
connectivity, defining 238

D

DCOLOR parameter 259
default status descriptor color 259
define
 color for SDF 263
 I/O errors for SDF 270
 maximum number of SDF
 operators 265
 SDF color/priority range 269
 SDF color/priority relationship 266
 SDF initial panel 264
 SDF PF keys 260, 261, 262, 265
 SDF screen buffer size 270
 status colors 263
DELETE FILE command 189
descriptor codes 35
disability xi
DPFKDESC1 parameter 261
DPFKDESC2 parameter 262
DPFKnn parameter 260

E

EHKACTION task global variable 71
EHKCMD task global variable 15
EHKCMDTEXT task global variable 15
EHKXITNME task global variable 48
EHKXITRSN task global variable 48,
49
EHKRPY task global variable 26, 29
EHKRPYHI task global variable 29
EHKRPYTEXT task global variable 29
EHKVARN task global variables 15, 29
EMPTYCOLOR parameter 263
ENDPANEL statement 285
ERRCOLOR 263

F

FICON cascaded switches 175
FICON switches 175
file manager commands
 ACF 7
 ACFFQRY 20
 ASF 62
 ASFUSER 67
filtering messages 104
FWDMSG generic routine 108

G

generic routines
 ACTIVMSG 101
 AOCFILT 104
 AOFCPMSG 105
 description 101
 FWDMSG 108
 HALTMSG 110
 INGMON 112
 ISSUEACT 118
 ISSUECMD 118
 OUTREP 125
 TERMMMSG 127

H

HALTMSG generic routine 110

I

I/O operations
 programming commands 173
I/O operations commands
 DELETE FILE 189
 QUERY ENTITY CHP 189
 QUERY ENTITY CNTLUNIT 195
 QUERY ENTITY DEV 198
 QUERY ENTITY HOST 200
 QUERY ENTITY SWITCH 203
 QUERY FILE 206
 QUERY INTERFACE
 CNTLUNIT 207
 QUERY INTERFACE SWITCH 212
 QUERY RELATION CHP 219
 QUERY RELATION CNTLUNIT 220
 QUERY RELATION DEV 220
 QUERY RELATION HOST 221
 QUERY RELATION SWITCH 222
 QUERY SWITCH 223
REMOVE CHP 226
REMOVE DEV 229
RESTORE CHP 226
RESTORE DEV 229
WRITEFILE 235
WRITEPORT 236
WRITESWCH 241
ING\$QRY 167
INGALERT system utility 134
INGCNTL command 76
INGCPSM system utility 136
INGDATA system utility 137
INGLINK system utility 139
INGMON generic routine 112
INGMTRAP system utility 142
INGOMX system utility 143
INGPJMON common routine 97
INGPOST common routine 78
INGPSMON common routine 98
INGQRY command 81
INGRCLUP command 82
INGRTCMD command 83
INGSIT system utility 150
INGSTOBS system utility 153
INGSTX command 155
INGTIMER command 159
INGUSS command 83
INGVARS command 162
 line-mode output 163
INGVMON common routine 99
INGVSTOP command 88
INGVSTRT command 87
INGVTAM command 164
initialization parameters
 DCOLOR 259
 DPFKDESC1 261
 DPFKDESC2 262
 DPFKnn 260
 EMPTYCOLOR 263
 ERRCOLOR 263
 INITSCRN 264
 MAXOPS 265

initialization parameters (*continued*)

 PFKnn 265
 PRIORITY 266
 PRITBSZ 269
 PROPDOWN 269
 PROPUP 270
 SCREENSZ 270
 TEMPERR 270
INITSCRN parameter 264
ISQMTSYS common routine 100
ISSUEACT generic routine 118
ISSUECMD generic routine 118

K

keyboard xi

L

languages supported by the API
 Assembler language 254
 REXX 249
 MVS REXX example 250
load
 QUERY FILE command 206
load SDF tree structure 293
LookAt message retrieval tool xiv

M

mask 236, 238
MAXOPS parameter 265
MDFYSHUT common routine 90
message forwarding and
 notification 108
message generation and notification 34
message retrieval tool, LookAt xiv
modifying the current shutdown 90
monitoring routine
 INGSTOBS 153
monitoring routines
 AOFADMON 93
 AOFAPMON 94
 AOFATMON 94
 AOFCPSPM 95
 AOFNCMON 95
 AOFUXMON 96
 INGPJMON 97
 INGPSMON 98
 INGVMON 99
 ISQMTSYS 100
MVS descriptor codes 35
MVS REXX example 250

N

NetView
 Automation Table Function
 ING\$QRY 167
 DSIPARM member 273

O

operating environment requirements 173
OUTREP generic routine 125

P

PANEL statement 276
panels
 Code Processing 72, 126
 DISPACF 123, 131
 Message Processing 18
 thresholds definition 75
parameter list
 for I/O operations API 251
PF key
 defining for SDF 265
PFKnn parameter 265
PIB, see port information block 223
port information block (PIB) 223
PRIORITY parameter 266
PRITBSZ parameter 269
PROPDOWN parameter 269
PROPUP parameter 270

Q

QUERY ENTITY CHP command 189
QUERY ENTITY CNTLUNIT
 command 195
QUERY ENTITY DEV command 198
QUERY ENTITY HOST command 200
QUERY ENTITY SWITCH
 command 203
QUERY FILE command 206
QUERY INTERFACE CNTLUNIT
 command 207
QUERY INTERFACE SWITCH
 command 212
QUERY RELATION CHP command 219
QUERY RELATION CNTLUNIT
 command 220
QUERY RELATION DEV command 220
QUERY RELATION HOST
 command 221
QUERY RELATION SWITCH
 command 222
QUERY SWITCH command 223

R

REMOVE CHP command 226
REMOVE DEV command
 RESTORE DEV command 229
resource attribute, INGQRY
 command 81
RESTORE CHP command 226
REXX coding instructions 249
REXX EXEC
 MVS example 250

S

sample SDF, definition 285
save switch configuration
 WRITEFILE command 235
saved switch configuration
 load file at IPL 206
scheduling a command 56
SCREEN command 295
SCREENSZ parameter 270

SDF
 automation control file entry 259
 initialization parameters 259
 sample definition 285
 tree structure hierarchy 273
SDF definition statements
 AOF TREE 273
 ENDPANEL 285
 PANEL 276
 PFKnn 283
 SCREEN 295
 SDFPANEL 294
 SDF TREE 293
 STATUSFIELD 277
 STATUSTEXT 280
 TEXTFIELD 281
 TEXTTEXT 283
shortcut keys xi
status descriptor color 259
status tree 269, 270
STATUSFIELD statement 277
STATUSTEXT statement 280
store
 WRITEFILE command 235
structure definitions
 AOF TREE 273
 ENDPANEL 285
 PANEL 276
 PFKnn 283
 SCREEN 295
 SDFPANEL 294
 SDF TREE 293
 STATUSFIELD 277
 STATUSTEXT 280
 TEXTFIELD 281
 TEXTTEXT 283
SUBPAPPL task global variable 46
SUBPASID task global variable 47
SUBPCATEGORY task global
 variable 47
SUBPCMDPFX task global variable 47
SUBPDESC task global variable 47
SUBPEXTSTART task global variable 47
SUBPEXTSTOP task global variable 47
SUBPFILE task global variable 47
SUBPINFOLINK task global variable 47
SUBPIPLOTT task global variable 47
SUBPJOB task global variable 47
SUBPJOBTYPE task global variable 47
SUBPMDATE task global variable 47
SUBPMTIME task global variable 47
SUBPOPER task global variable 47
SUBPPARENT task global variable 47
SUBPPATH task global variable 47
SUBPPID task global variable 47
SUBPPORT task global variable 47
SUBPPROC task global variable 47
SUBPPROCESS 47
SUBPRSTOPT task global variable 47
SUBPSCHEDSS task global variable 47
SUBPSDATE task global variable 47
SUBPSESS task global variable 47
SUBPSHUTDLY task global variable 47
SUBPSPARM task global variable 47
SUBPSTARTTYPE task global
 variable 47
SUBPSTAT task global variable 47

SUBPSTIME task global variable 47
SUBPSTOPTYPE task global variable 47
SUBPSTRTDLY task global variable 48
SUBPSUBCAT task global variable 48
SUBPSUBID task global variable 48
SUBPSUBTYPE task global variable 48
SUBPTERMDLY task global variable 48
SUBPTRANTY task global variable 48
SUBPTYPE task global variable 48
SUBPUSER task global variable 48
SUBPUSSJOB task global variable 48
SUBPWLMNAME task global
 variable 48
SUBPWTOR task global variable 48
SUBPxxxx task global variables 44
SUBSAPPL task global variable 45
SUBSASID task global variable 45
SUBSASSIST task global variable 49
SUBSCATEGORY task global
 variable 45
SUBSCMDPFX task global variable 45
SUBSDESC task global variable 45
SUBSEXTSTART task global variable 45
SUBSEXTSTART TGLOBAL 45
SUBSEXTSTOP task global variable 45
SUBSEXTSTOP TGLOBAL 45
SUBSFILE TGLOBAL 45
SUBSINFOLINK task global variable 45
SUBSIPLT task global variable 45
SUBSIPLT TGLOBAL 45
SUBSJOB task global variable 45
SUBSJOB TGLOBAL 45
SUBSJOBTYPE task global variable 45
SUBSJOBTYPE TGLOBAL 45
SUBSMDATE task global variable 45
SUBSMTIME task global variable 45
SUBSOPER task global variable 45
SUBSPARENT task global variable 45
SUBSPATH task global variable 45
SUBSPID task global variable 45
SUBSPORT task global variable 45
SUBSPROC task global variable 45
SUBSPROCESS task global variable 45
SUBSRSTOPT task global variable 45
SUBSSCHEDSS task global variable 46
SUBSSDATE task global variable 46
SUBSSSESS task global variable 46
SUBSSHUTDLY task global variable 46
SUBSSPARM task global variable 46
SUBSSTARTTYPE task global
 variable 46
SUBSSTAT task global variable 46
SUBSSTIME task global variable 46
SUBSSTOPTYPE task global variable 46
SUBSSTRTDLY task global variable 46
SUBSSUBCAT task global variable 46
SUBSSUBID task global variable 46
SUBSSUBTYPE task global variable 46
SUBSTERMDLY task global variable 46
SUBSTRANTY task global variable 46
SUBSTYPE task global variable 46
SUBSUSER task global variable 46
SUBSUSJOB task global variable 46
SUBSWLMNAME task global
 variable 46, 48
SUBSWTOR task global variable 46
SUBSxxxx task global variables 44

- switch
 - FICON 175
 - FICON cascaded 175
- syntax diagrams
 - how to read 3
- system hierarchy tree 58
- system operations
 - common routines for programming 7
 - generic routines for programming 101
- system operations commands
 - INGCNTL 76
 - INGPOST 78
 - INGQRY 81
 - INGRCLUP 82
 - INGRTCMD 83
 - INGUSS 83
 - INGVSTOP 88
 - INGVSTRT 87
- system utility
 - AOFRACON 133
 - INGALERT 134
 - INGCPSM 136
 - INGDATA 137
 - INGLINK 139
 - INGMTRAP 142
 - INGOMX 143
 - INGSIT 150
 - INGSTOBS 153
 - INGSTX 155
 - INGTIMER 159
 - INGVARS 162
 - INGVTAM 164

T

- TEMPERR parameter 270
- TERMMSG generic routine 127
- TEXTFIELD statement 281
- TEXTTEXT statement 283

U

- user-written programs
 - calling the API 173

W

- WRITEFILE command 235
- WRITEPORT command 236
 - 256-character allow or prohibit string 238
 - example 239
- WRITESWCH command 241

Readers' Comments — We'd Like to Hear from You

System Automation for z/OS
Programmer's Reference
Version 3 Release 2

Publication No. SC33-8266-03

We appreciate your comments about this publication. Please comment on specific errors or omissions, accuracy, organization, subject matter, or completeness of this book. The comments you send should pertain to only the information in this manual or product and the way in which the information is presented.

For technical questions and information about products and prices, please contact your IBM branch office, your IBM business partner, or your authorized remarketer.

When you send comments to IBM, you grant IBM a nonexclusive right to use or distribute your comments in any way it believes appropriate without incurring any obligation to you. IBM or any other organizations will only use the personal information that you supply to contact you about the issues that you state on this form.

Comments:

Thank you for your support.

Submit your comments using one of these channels:

- Send your comments to the address on the reverse side of this form.
- Send a fax to the following number: FAX (Germany): 07031+16-3456
FAX (Other Countries): (+49)+7031-16-3456
- Send your comments via e-mail to: s390id@de.ibm.com

If you would like a response from IBM, please fill in the following information:

Name

Address

Company or Organization

Phone No.

E-mail address



Fold and Tape

Please do not staple

Fold and Tape



NO POSTAGE
NECESSARY
IF MAILED IN THE
UNITED STATES

BUSINESS REPLY MAIL

FIRST-CLASS MAIL PERMIT NO. 40 ARMONK, NEW YORK

POSTAGE WILL BE PAID BY ADDRESSEE

IBM Deutschland Entwicklung GmbH
Department 3248
Schoenaicher Strasse 220
D-71032 Boeblingen
Federal Republic of Germany



Fold and Tape

Please do not staple

Fold and Tape



Program Number: 5698-SA3

Printed in USA

SC33-8266-03

