



IBM eServer™

Now Serving Java on the Mainframe with zAAP.

Introducing the zSeries Application Assist Processor

January 26, 2005
2 PM Eastern

Delivering a specialized z/OS Java execution environment for customers who desire the powerful integration advantages and core strengths of the zSeries platform

Trademarks

The following are trademarks of the International Business Machines Corporation in the United States and/or other countries.

AIX*	FlashCopy*	Performance Toolkit for VM
CICS*	HyperSockets	PR/SM
DB2*	HyperSwap	RMF
DHSMSrmm	IBM*	S/390*
DFSORT*	IBM eServer	Tivoli*
Domino	IBM logo*	TotalStorage*
e-business logo*	IMS	VSE/ESA
e-business on demand	iSeries	z/VSE
Enterprise Storage Server*	Language Environment*	WebSphere*
ESCON*	Lotus*	z/OS*
FICON	OS/390*	z/VM*
FICON Express	Parallel Sysplex*	zSeries*
* Registered trademarks of IBM Corporation		zSeries Entry License Charge

The following are trademarks or registered trademarks of other companies.

Java and all Java-related trademarks and logos are trademarks of Sun Microsystems, Inc., in the United States and other countries

UNIX is a registered trademark of The Open Group in the United States and other countries.

Microsoft, Windows and Windows NT are registered trademarks of Microsoft Corporation in the United States, other countries, or both.

SET and Secure Electronic Transaction are trademarks owned by SET Secure Electronic Transaction LLC.

* All other products may be trademarks or registered trademarks of their respective companies.

Notes:

Performance is in Internal Throughput Rate (ITR) ratio based on measurements and projections using standard IBM benchmarks in a controlled environment. The actual throughput that any user will experience will vary depending upon considerations such as the amount of multiprogramming in the user's job stream, the I/O configuration, the storage configuration, and the workload processed. Therefore, no assurance can be given that an individual user will achieve throughput improvements equivalent to the performance ratios stated here.

IBM hardware products are manufactured from new parts, or new and serviceable used parts. Regardless, our warranty terms apply.

All customer examples cited or described in this presentation are presented as illustrations of the manner in which some customers have used IBM products and the results they may have achieved. Actual environmental costs and performance characteristics will vary depending on individual customer configurations and conditions.

This publication was produced in the United States. IBM may not offer the products, services or features discussed in this document in other countries, and the information may be subject to change without notice. Consult your local IBM business contact for information on the product or services available in your area.

All statements regarding IBM's future direction and intent are subject to change or withdrawal without notice, and represent goals and objectives only.

Information about non-IBM products is obtained from the manufacturers of those products or their published announcements. IBM has not tested those products and cannot confirm the performance, compatibility, or any other claims related to non-IBM products. Questions on the capabilities of non-IBM products should be addressed to the suppliers of those products.

Prices subject to change without notice. Contact your IBM representative or Business Partner for the most current pricing in your geography.

Speakers

- **Michael Dickson, IBM**
*worldwide On Demand Offering
Manager for IBM eServer zSeries*
- **Les Wyman, IBM Systems**
*Architecture and Design for IBM
eServer zSeries*
- **Robert Creedon, IBM Business**
*Development Manager for zSeries
Websphere and SSA Global for
eServer*



Table of Contents

- **Strategic Intent, Concept & Value**
- **zAAP Pre-reqs & Technical Insight**
- **How to Plan for zAAP**
- **Special Programs & Offers**
- **Q&A Session**





IBM eServer™

Strategic Intent, Concept Overview & Value Proposition

Michael Dickson
zSeries Marketing Manager
dicksonm@us.ibm.com

Marketplace Insight

- **The On Demand™ Era is here**
- **Strategic Web-based Application exploitation is increasing at exponential rates**
- **Web-based Applications can be a source of Competitive Advantage**
- **Web-based Application workloads are often unpredictable**
- **IT Budgets are not growing exponentially**

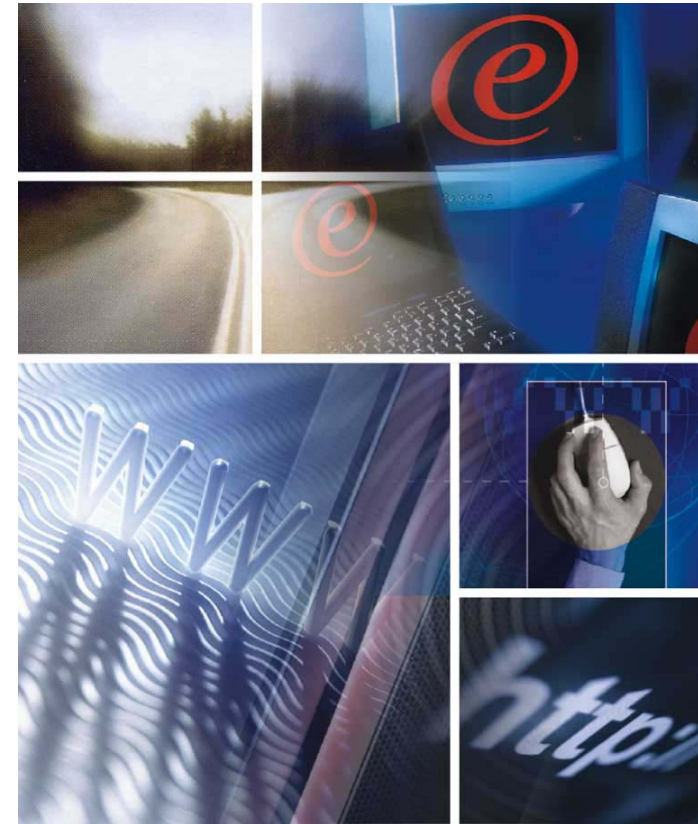

The zSeries Application Assist Processor

New specialty assist processor dedicated exclusively to execution of Java workloads under z/OS®

- ▶ Enables integration of new Java based Web applications with core z/OS backend database environment
- ▶ Can help simplify and reduce server infrastructure and improve operational efficiencies over distributed multi-tier solutions.
- ▶ Executes Java with the same reliability, availability and security you've come to expect from the mainframe...with no changes to applications
- ▶ Reduces up front and maintenance costs for workloads with Java cycles e.g.: WebSphere®, DB2®
- ▶ Provides additional capacity at low cost of acquisition to process Java without affecting MSU rating or machine model designation...No additional IBM software costs

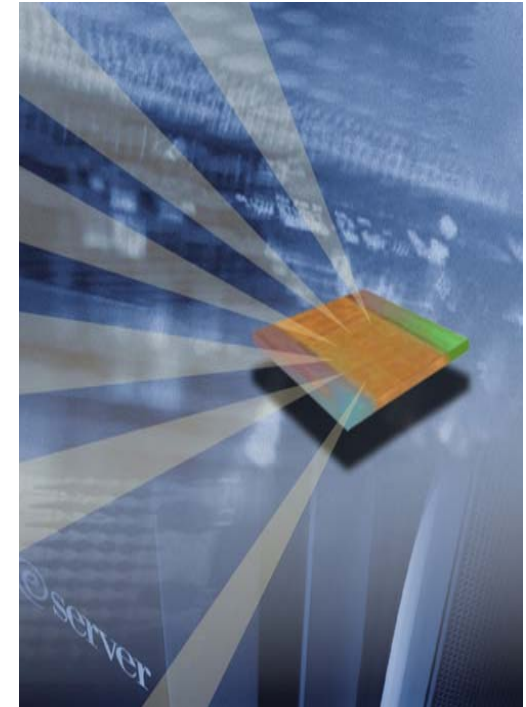

Objective: Enable integration of new Java based Web applications with core z/OS backend database environment for high performance, reliability, availability, security, and lower total cost of ownership

Leveraging zAAPs for e-business Integration and Infrastructure Simplification

- **zAAPs can help consolidate, simplify and reduce server infrastructure and improve operational efficiencies.**
 - ▶ Enables strategic integration of e-business applications with mission-critical database workloads
 - ▶ Potential operational advantages over distributed multi-tier solutions
- **Eliminates separate tier to handle application server workload**
 - ▶ Remove one hardware tier
 - ▶ Remove one TCP/IP link
- **Leverage core zSeries strengths and manage Java Workloads automatically with z/OS**
 - ▶ zSeries Security
 - ▶ zSeries Workload Manager (WLM)
 - ▶ zSeries Availability
 - ▶ zSeries Scalability
 - ▶ zSeries Flexibility

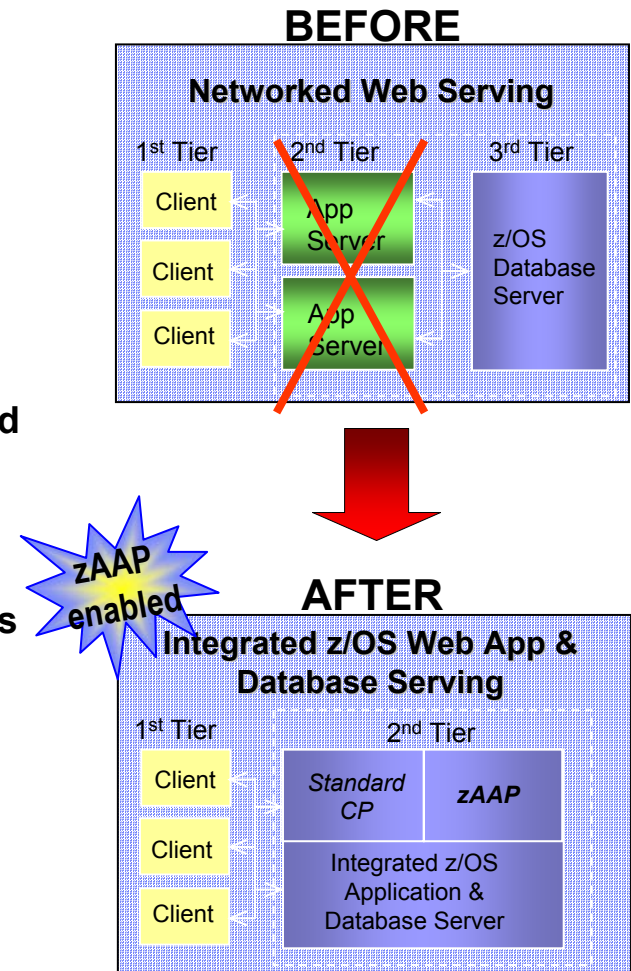

zAAP Concept Overview: A Simplified Example...

Consider a WebSphere Application that is transactional in nature and requires 1000 MIPS today on zSeries.

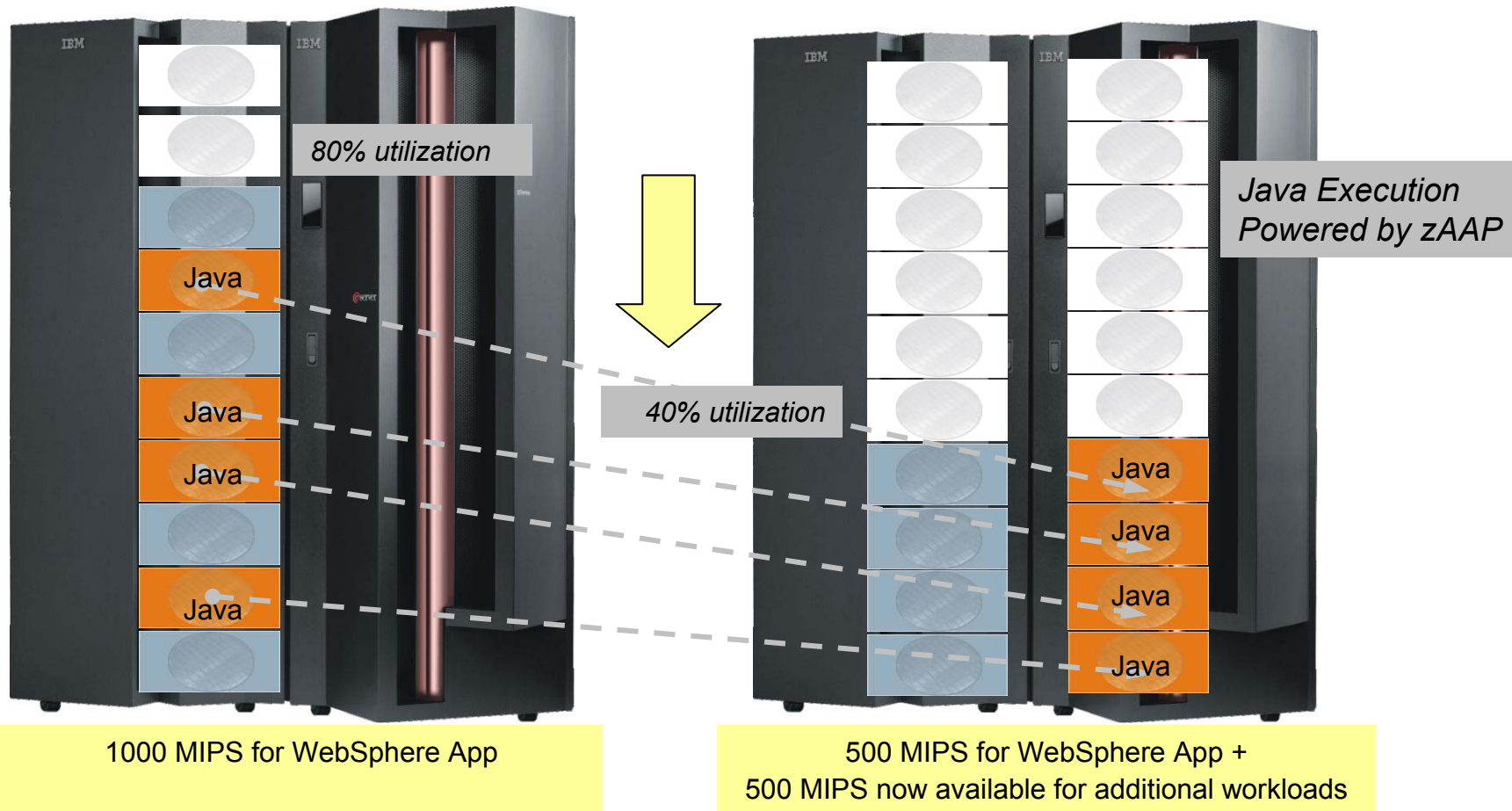

In this example, with zAAP, we can reduce the standard CP capacity requirement for the Application to 500 MIPS or a 50% reduction. * For illustrative purposes only

zAAP Impact on Full Capacity Pricing Scheme

BEFORE zAAP:

- Machine Type: 2084-B16
- Rated @ 647 MSUs
- Full-Capacity EWLC @ 647 MSUs
- Average Prime Shift Machine Utilization = 80%

AFTER zAAP:

- Machine Type: 2084-B16
- Rated @ 647 MSUs
- Java cycles executed on zAAPs
- Full Capacity EWLC remains @ 647 MSUs
- Average Prime Shift Machine Utilization = 50%

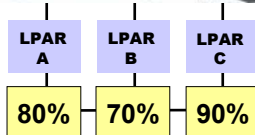
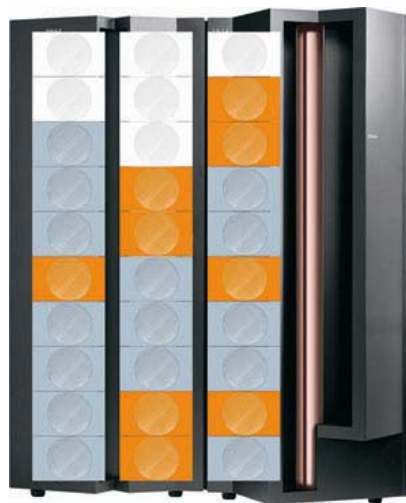

Average LPAR Utilization

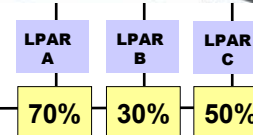
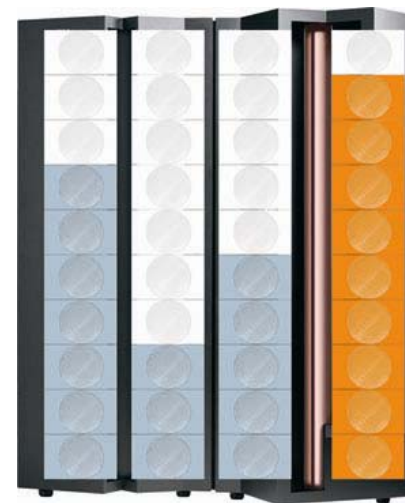

zAAP Impact on Sub-Capacity Pricing Scheme

BEFORE zAAP:

- Machine Type: 2084-B16
- Rated @ 647 MSUs
- Sub-Capacity Pricing based on;
 - LPAR A rolling 4hr avg @ 233 MSUs
 - LPAR B rolling 4hr avg @ 200 MSUs
 - LPAR C rolling 4hr avg @ 267 MSUs
- Rolling 4hr avg of Machine = 547 MSUs
- Average Prime Shift Machine Utilization = 80%

AFTER zAAP:

- Machine Type: 2084-B16
- Rated @ 647 MSUs
- Java cycles executed on zAAPs
- New Sub-Capacity Pricing on *reduced* rolling 4hr avg
 - LPAR A rolling 4hr avg @ 213 MSUs
 - LPAR B rolling 4hr avg @ 100 MSUs
 - LPAR C rolling 4hr avg @ 167 MSUs
- New Rolling 4hr avg of Machine = 480 MSUs
- Average Prime Shift Machine Utilization = 50%

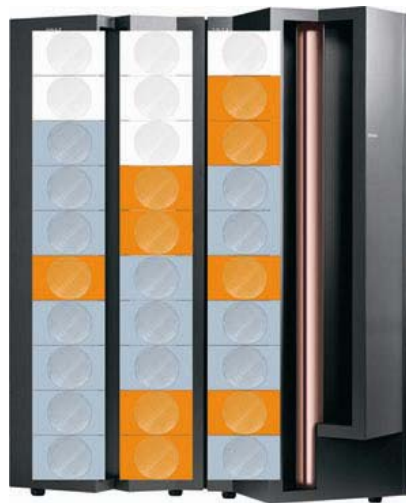

LPAR A	LPAR B	LPAR C
80%	70%	90%
233	200	267

Average LPAR Utilization

Sub-Capacity MSUs

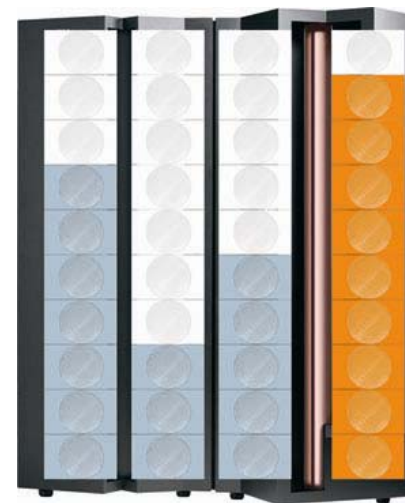

LPAR A	LPAR B	LPAR C	zAAP
70%	30%	50%	
213	100	167	



IBM eServer™

zAAP Pre-Reqs & Technical Insight

Les Wyman

zSeries Systems Architect (zAAP Design Team Member)

lwyman@us.ibm.com

Requirements for zAAP Exploitation

- Available on z990, z890 and follow-on models only
- Prerequisites:
 - z/OS 1.6 (or z/OS.e 1.6)
 - IBM SDK for z/OS, Java 2 Technology Edition, V1.4 with PTF for APAR PQ86689
- Subsystems and Apps using SDK 1.4 will exploit zAAPs automatically, for example:
 - WAS 5.1
 - CICS® /TS 2.3
 - DB2 V8
 - IMS™ V8
 - WebSphere WBI for z/OS
 - Java Batch
- zAAPs must be jointly configured with general purpose processors within z/OS LPARs
 - Number of zAAPs may not exceed the number of permanently purchased CPs (including z990 unassigned CPs or z890 Downgrade - Record Only CPs) on a given machine model
- **zAAPs are transparent to JAVA applications: No application modifications are required**



zAAP Architecture and Workflow: Executing Java under IBM JVM control

- IBM JVM, parts of LE runtime, and z/OS Supervisor needed to support JVM execution can operate on zAAPs
- IBM JVM communicates to z/OS dispatcher when Java code is to be executed
 - When Java is to be executed, the work unit is "eligible" to be dispatched on a zAAP
- z/OS dispatcher attempts to dispatch zAAP eligible work on a zAAP (when present)
 - zAAP ineligible work only dispatched on standard processors
- If there is insufficient zAAP capacity available, or standard processors are idle, the dispatcher may dispatch zAAP eligible work on a standard processor
 - There is an installation control to limit the use of standard processors to execute zAAP eligible work (see Java code execution options)

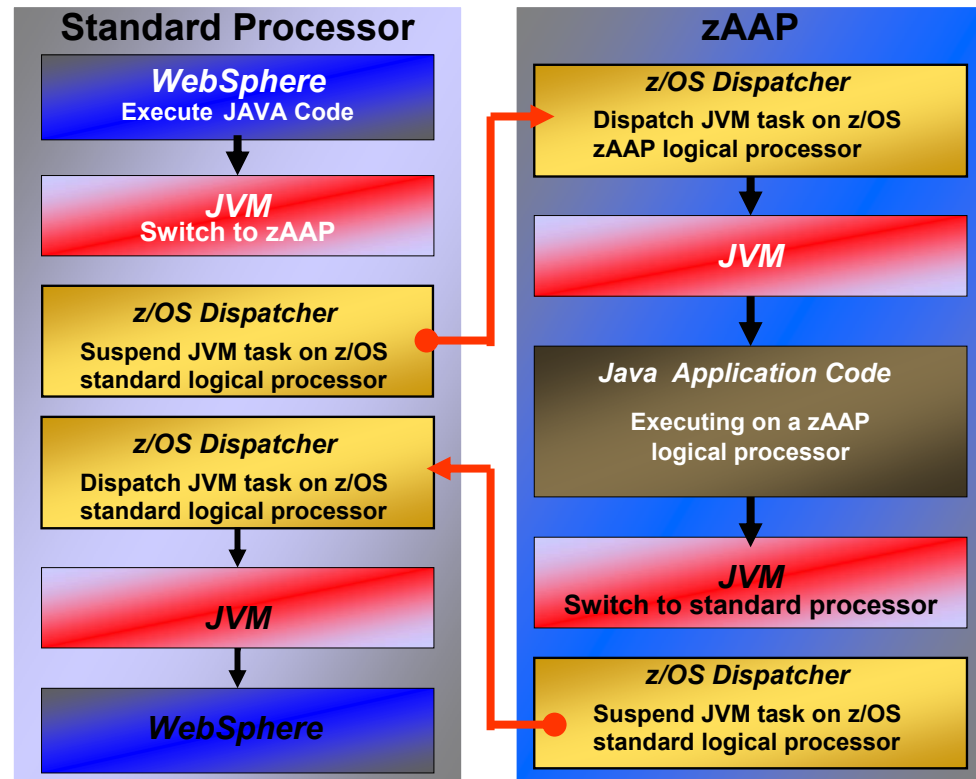

Configuration example: z/OS zAAP Partitions

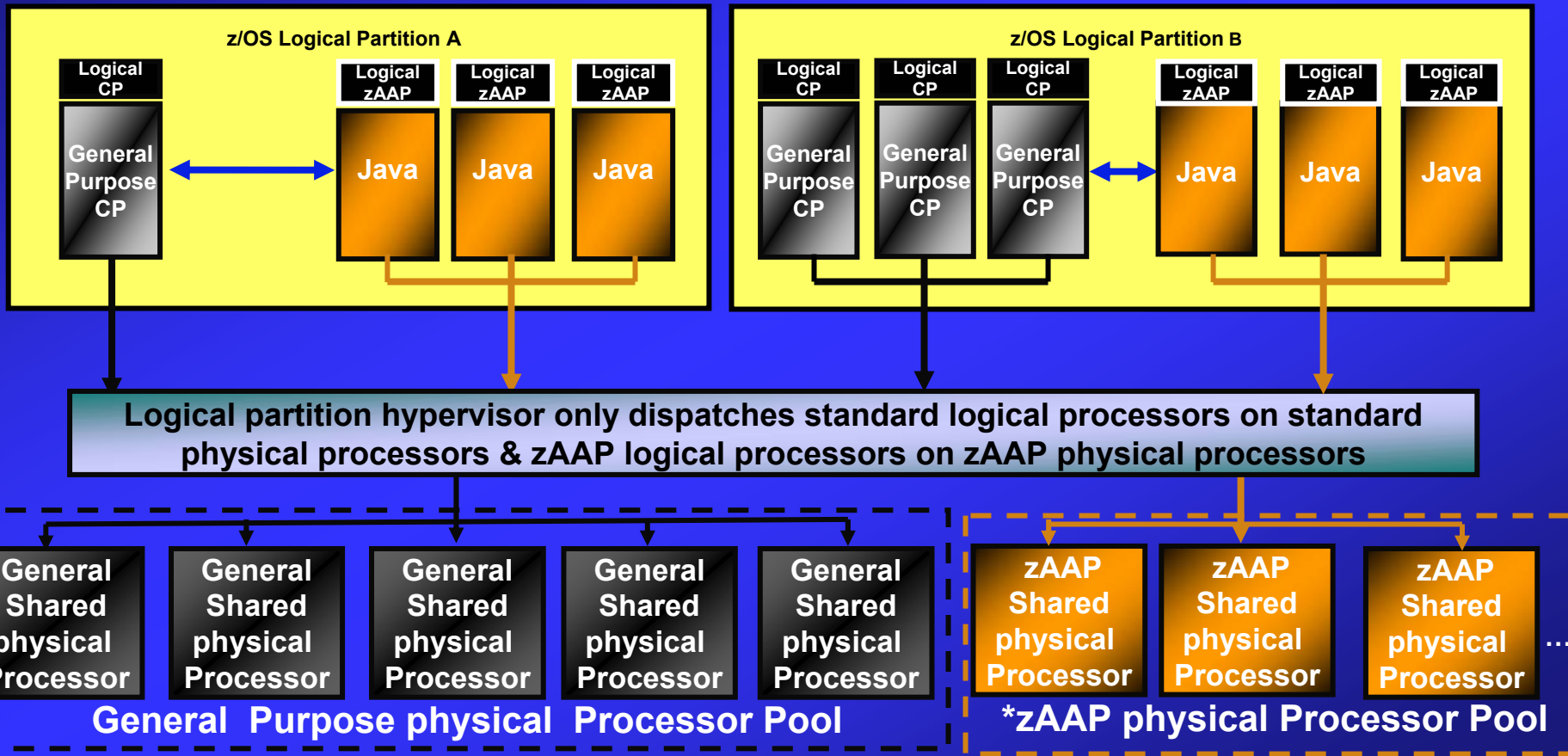

zAAP Configuration Execution Options

- zAAPs are Configured via the Normal PR/SM™ Logical Partition Image Profile
- Java Application code can be executed under any of the following user specified options:
 - *Option 1 - Java by Priority (IFAHONOR_PRIORITY = Yes)*
 - Standard processors execute both Java and non-Java work in priority order (as when zAAPs are not configured)
 - *Option 2 - Java Discretionary Crossover (IFAHONOR_PRIORITY = No)*
 - Standard processors execute non-Java work in priority order and Java work in priority order only when there is no non-Java work to execute
 - *Option 3 - No Java Crossover (IFACrossover = No)*
 - Standard processors execute only non-Java work in priority order
 - *The selected switching option can be dynamically changed by a SET OPT command*

zAAP Integration at Work: Java App calling DB2

z/OS Logical Partition

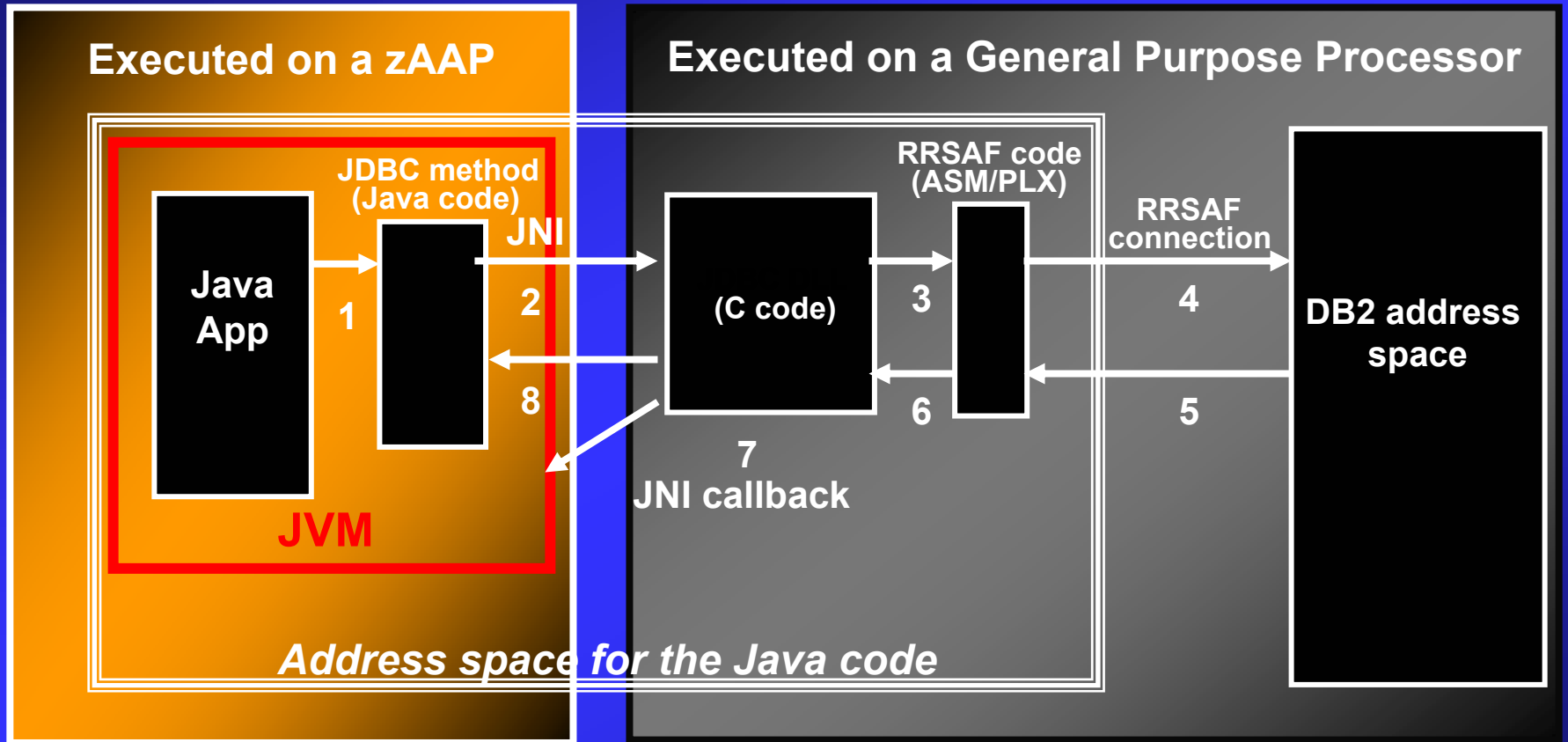

Very Tight SMP Based Application & Data Base Integration

zAAP Characteristics: How zAAPs Differ from General Purpose Processors

■ Some zAAPs Limitations

- zAAPs cannot be IPLed
- zAAPs only executes z/Architecture™ mode instructions
- zAAPs do not support all manual operator controls
 - No: PSW Restart, LOAD or LOAD derivatives (load from file, CDROM, Server)
- zAAPs don't respond to SIGP requests unless enabled by a z/OS that supports zAAPs
- Additional architecture differences are anticipated in future implementations
 - e.g., Java specific performance enhancements

■ The z/OS design accommodates processor differences for zAAPs; e.g.,

- No I/O interrupts
- No Clock Comparator interrupts

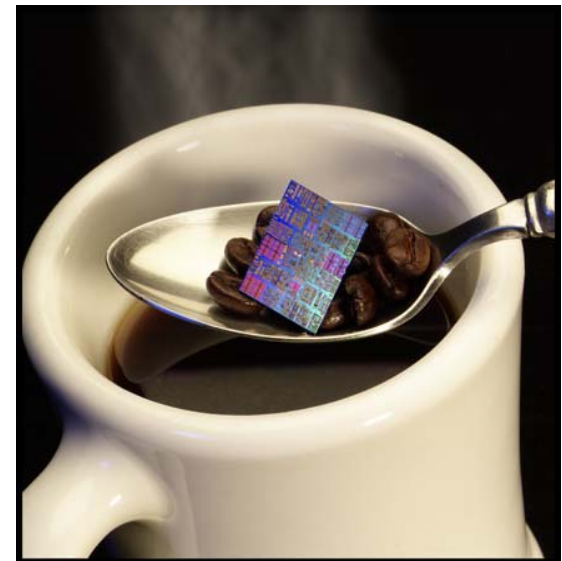

RMF™ zAAP Support

- RMF supports zAAP processors by extending the
 - **Postprocessor CPU activity report**
 - **Postprocessor Workload report**
 - **Monitor III Enclave report**
- In detail...
 - **RMF distinguishes between standard CP and zAAP processors where necessary**
 - **Collects and reports about zAAP service times**
 - **Collects and reports about zAAP using and delay states for service and report class periods**
- This support is shipped as SPE (APAR OA05371)
 - **PTFs will be available for z/OS V1.5 RMF - Allows planning to start now**
 - **UA90081 (Base)**
 - **UA90082 (Kanji)**

Updated SMF Records for zAAP

- Following SMF record types are extended
 - **SMF record 70 subtype 1 (CPU activity)**
 - **SMF record 72 subtype 3 (Workload activity)**
 - **SMF record 79 subtype 1 and 2 (Address Space State and Resource data)**

- Review and modify user written programs, if affected

Total Value of z/OS 1.6

- **Extending z/OS scale**
 - Support for up to 24 engines in a single z/OS image (1.6)
 - Greater than 24 engines SOD
 - Improved scalability of WebSphere (1.6)
- **Extending Application flexibility & scalability**
 - **Support for zSeries Application Assist Processor (zAAP) (1.6)**
 - 64-bit application development with 64-bit C/C++ and 64-bit Java SOD (1.6)
- **Security**
 - Multilevel security for hosting users with different security levels (1.5)
 - Enhanced Intrusion Detection Services (1.5)
- **Self-optimizing**
 - Simplified Workload Manager control for WebSphere (1.5)
 - Prioritizing critical data sets on Parallel Access Volumes (1.6)
- **Simplification**
 - Easier setup of z/OS functions using Managed System for Setup (1.5)
 - Enhanced Internet access to z/OS library (1.5)
 - Easier management of print with new InfoPrint® front end (1.5)
 - Tape management across platforms (1.6)



	GA	End of ordering	End of service
z/OS 1.4	9/02	9/04	3/07
z/OS 1.5	3/04	9/04	3/07
z/OS 1.6	9/04	tbd	tbd

* All statements regarding IBM future direction and intent are subject to change or withdrawal without notice, and represent goals and objectives only.



IBM eServer™

How to Plan for zAAP Performance & Capacity Planning Insight

Bob Creedon

zSeries Business Development Manager for WebSphere
rcreedon@us.ibm.com

zAAP Performance & Capacity Planning

Theoretical example: 100% WebSphere workload with greater than 50% Java content, zAAP full utilization. All have same WLM goal

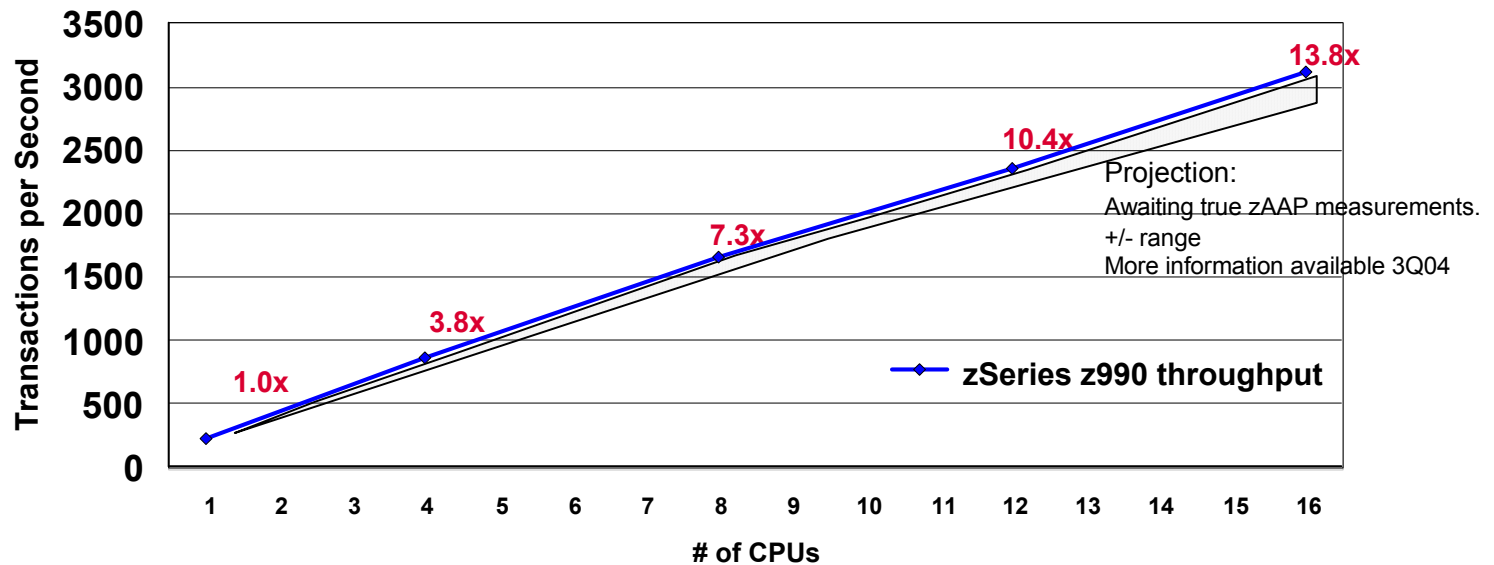

Possible Combinations
CPs + zAAPs

	1+1	2+1	3+1 2+2	4+1 3+2	5+1 4+2 3+3	6+1 5+2 4+3	7+1 6+2 5+3 4+4	8+1 7+2 6+3 5+4	9+1 8+2 7+3 6+4 5+5	10+1 9+2 8+3 7+4 6+5	11+1 10+2 9+3 8+4 7+5 6+6	12+1 11+2 10+3 9+4 8+5 7+6	13+1 12+2 11+3 10+4 9+5 8+6 7+7	14+1 13+2 12+3 11+4 10+5 9+6 8+7	15+1 14+2 13+3 12+4 11+5 10+6 9+7 8+8
--	-----	-----	------------	------------	-------------------	-------------------	--------------------------	--------------------------	---------------------------------	----------------------------------	--	---	---	--	--

Note:

Numbers in Red depict estimated SMP scaling ratios
Assume greater than 50% JVM content that could be handled by zAAP

z890 zAAP Support

✦ Asymmetric zAAP processor speeds supported by z/OS 1.6

- ✦ zAAPs operate at full capacity
- ✦ Uni's : Max 1 zAAP
- ✦ 2-Ways: Max 2 zAAPs
- ✦ 3-Ways: Max 1 zAAP
- ✦ 4-Ways: None

zAAP Capacities

Uni's	2-ways (1.9)	3-ways (2.76)	4-ways (3.66)
26	50	72	95
46	88	127	168
88	167	243	322
110	210	304	403
172	327	475	630
210	399	580	769
366	696	1011	1340

Note! these are estimated MIPS subject to change

z990 Processor Details by Hardware Model

- z990 software model numbers indicate the number of PU assigned as CPs
 - 300 (no CPs) and 301 to 332 (1 to 32 CPs)
 - 3xx, where xx = the number of PU characterized as CPs in the CEC
 - Number of PUs assigned as CPs = Number of CP features ordered
 - Unassigned CP features are not counted here
- PUs assigned as zAAPs
 - Do not change the 3xx software number
 - Do not increase overall MSU rating of CEC or LPAR
 - Limited to no more than the number of CP's
 - Number of CPs = Sum of CP featured plus unassigned CP features

Models	MCMs	Available PUs	Standard SAPs	Standard Spares	Max oSAPs	Max CPs or IFLs	Max ICFs	Max zAAPs**
A08*	1	12	2	2	2	8	8	4
B16*	2	24	4	4	4	16	16	8
C24*	3	36	6	6	6	24	16	12
D32*	4	48	8	8	8	32	16	16

* Must have a minimum of one CP or IFL or ICF

** For each zAAP installed must have a corresponding CP

Java workload opportunities on zSeries

- Estimate 60% or more of z/OS customers have downloaded Java 2.
 - Install base for SDK 1.3 about 10x larger than SDK 1.4.
 - Most popular uses are, in order:
 - Batch (51%)
 - Web serving (46%)
 - DB query (43%)
 - Almost half intend to use with Websphere (43%)
 - Current largest scale Java applications in production are generally likely to be Domino
 - Most likely Java uses on z/OS:
 - New apps (67%)
 - Rewritten old apps (32%)
 - Linux: now 400+ customers

How Do I know if zAAP is Right for My Workloads?

Projecting zAAP eligibility for my Java workload

■ **“Java 2 Technology Edition, SDK 1.3.1 or SDK 1.4”**

- Specify Java runtime option “Xifa:project” which requests that zAAP projection records be written to stderr or SYSOUT in Websphere
- Available with Excel Summary Workbook for logs
- Gathers usage information on % of Java in your existing workloads that could execute on zAAP
- Useful in predicting number of zAAPs necessary for optimum configuration

■ **z/OS Performance: Capacity Planning Considerations for zAAP White Paper**

- Describes the zAAP Projection Tool and prototype measurements
- Describes Capacity Planning Methodology

■ **Size 390**

- Provides Special assistance for the sizing methodology described in White Paper
- May help with sizing consolidation of distributed Java workloads onto zSeries and zAAP(s)



Delivery of zAAP Planning materials

- **zAAP Projection Tool for Java 2 Technology Edition :**

- Downloadable form the Web
- This tool is an instrumented version of IBM Developer Kit for OS/390, Java 2 Technology Edition, product 5655-D35, at PTF UQ84703 (AKA SR22.) The tool contains all the Java SDK 1.3.1 product at that PTF level, and it adds a new capability to measure processor use
- The information on processor time is provided as messages in standard out for the SDK which is available in the z/OS JOBLOG file.
- <MV16.67109278> Interval at: 15:08:23 Duration: 00:00:19 Switches To/From IFA: 520/525 Java IFA: 22.680523 sec. Java Standard CPU 10.301010 sec. Interval address space CPU: 33.150526 sec.
- MV16.67109278> TOTAL at: 15:08:23 Duration: 00:03:22 Switches To/From IFA: 4992/4989 Java IFA: 231.096838 sec. Java Standard CPU 100.550773 sec. Total address space CPU: 333.648628 sec.
- A spreadsheet summarization tool is available to assist in the analysis of the zAAP Projection

Time at end of interval	duration	switch rate	zAAP seconds	CP seconds	Space seconds	zAAP% engine eligible	Other Java% engine	Appl% engine	zAAP% w/capture ratio	ZAAPs w/wait	Capture ratio:	Expected utilization:
10:01:26	00:03:21	50	222	98	322	110%	50%	160%	130%	1.7	85%	75%
09:59:06	00:01:01	48	65	28	95	107%	48%	155%	126%	1.7		
10:00:07	00:01:01	50	67	30	98	110%	50%	160%	130%	1.7		
10:01:08	00:01:01	51	69	31	100	113%	51%	164%	133%	1.8		
10:01:26	00:00:18	53	20	9	30	112%	53%	165%	132%	1.8		

Transaction profile - A Simplified Example

All workloads will have different utilization of zAAP and different arrival patterns

Example response time = 1 Sec, CPU time=.5 Sec

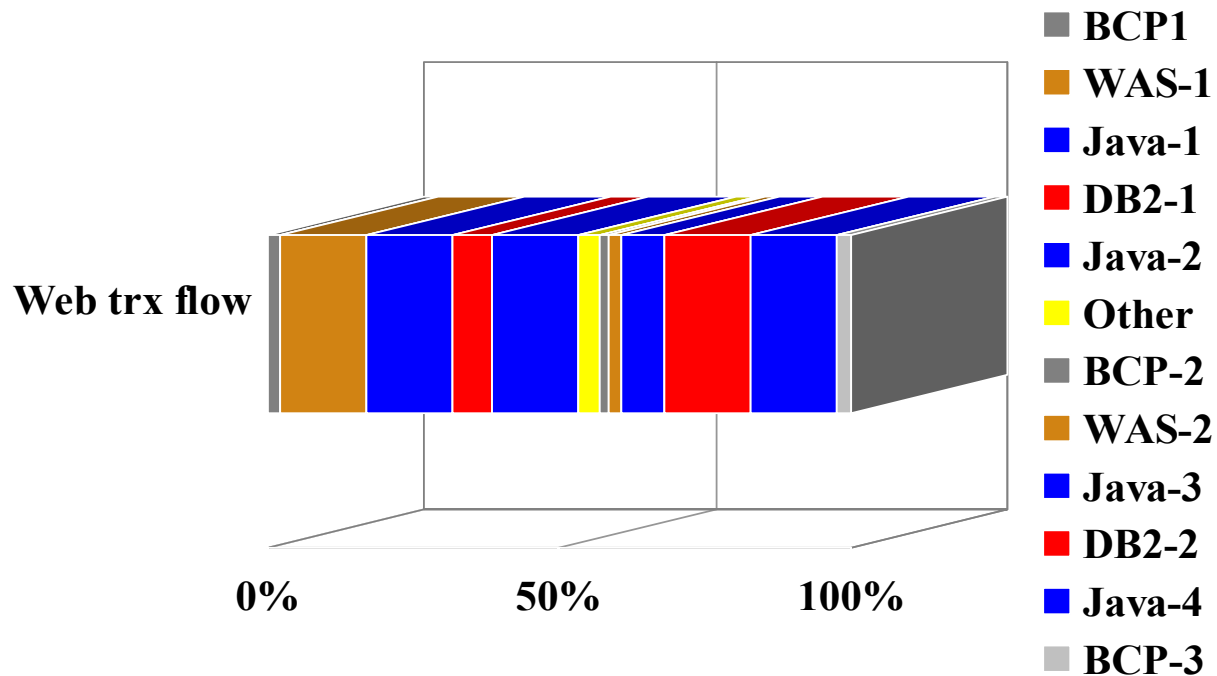

Transaction profile - A Simplified Example

All workloads will have different utilization of zAAP and different arrival patterns

Example response time = 1 Sec, CPU time=.5 Sec

Example response time = 1 Sec, General processor CPU time=.25 Sec zAAP time= .25 Sec

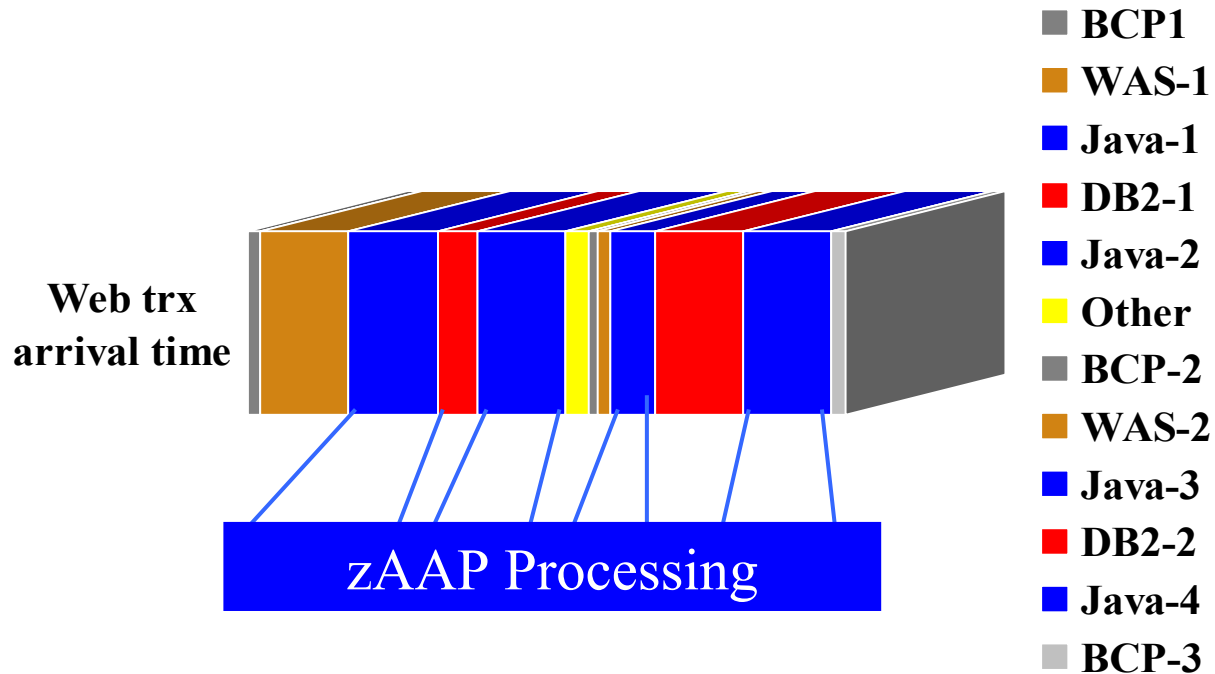

Transaction profile - A Simplified Example

All workloads will have different utilization of zAAP

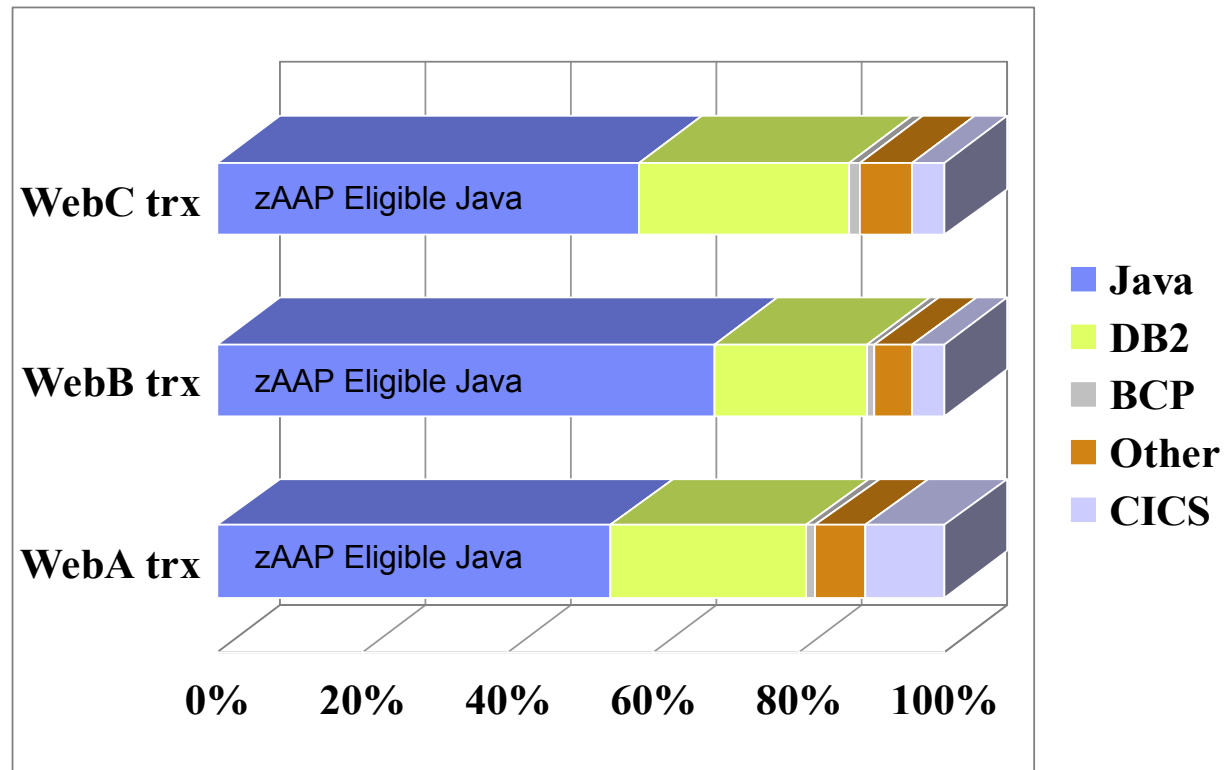

Excerpt from “z/OS Performance: Capacity Planning Considerations for zAAP Processors” White Paper (Page 3)

IBM Laboratory Measurements	JAVA Percentage of Total Workload CPU time
<p>XML Parse:</p> <p>Exercises parsing of XML documents, CPU-intensive activity, using either SAX or DOM parsing APIs with and without validity checking.</p>	98 %
<p>Trade 2:</p> <p>IBM developed workload modeling an electronic brokerage providing online securities trading. Provides a real-world eBusiness application mix of HTTP sessions, Servlets, JSPs, stateless session EJBs, container-managed persistent EJBs (CMPs) and JDBC data access to DB2. Generated with VA Java tooling, and characterized as light SQL with a small data base component.</p>	40 %
<p>Trade 3:</p> <p>Third generation of WebSphere end-to-end benchmark evolved from Trade 2 and covering J2EE 1.3 including the EJB 2.0 component architecture, Message Driven beans with PUB/SUB and point-to-point asynchronous messaging. Characterized as light SQL with a small data base component.</p>	60 %
<p>CTG/CICS ERW W :</p> <p>Web-Enabled access to a traditional CICS/DB2 OLTP database environment. J2EE application for legacy CICS transactions using servlets, JSPs, stateless session EJBs and the CICS Transaction Gateway (CTG). The size of the messages being passed between Websphere and CICS is relatively small. All the business logic is in the legacy CICS transactions and not in JAVA</p>	40 %
<p>IMS Connect ERW W :</p> <p>Web-Enabled access to a traditional IMS/DB2 OLTP data base environment. J2EE application for legacy IMS transactions using servlets, JSPs, stateless session EJBs and IMS Connect. The size of the messages being passed between Websphere and IMS is relatively small. All the business logic is in the legacy IMS transactions and not in JAVA.</p>	40 %
<p>IMS OLTP-T:</p> <p>Traditional IMS LSPR On-line Workload. Consists of light to moderate IMS transactions from DLI applications and using SNA LU2 message streams.</p>	0 %

Excerpt from “z/OS Performance: Capacity Planning Considerations for zAAP Processors” White Paper (Page 10)

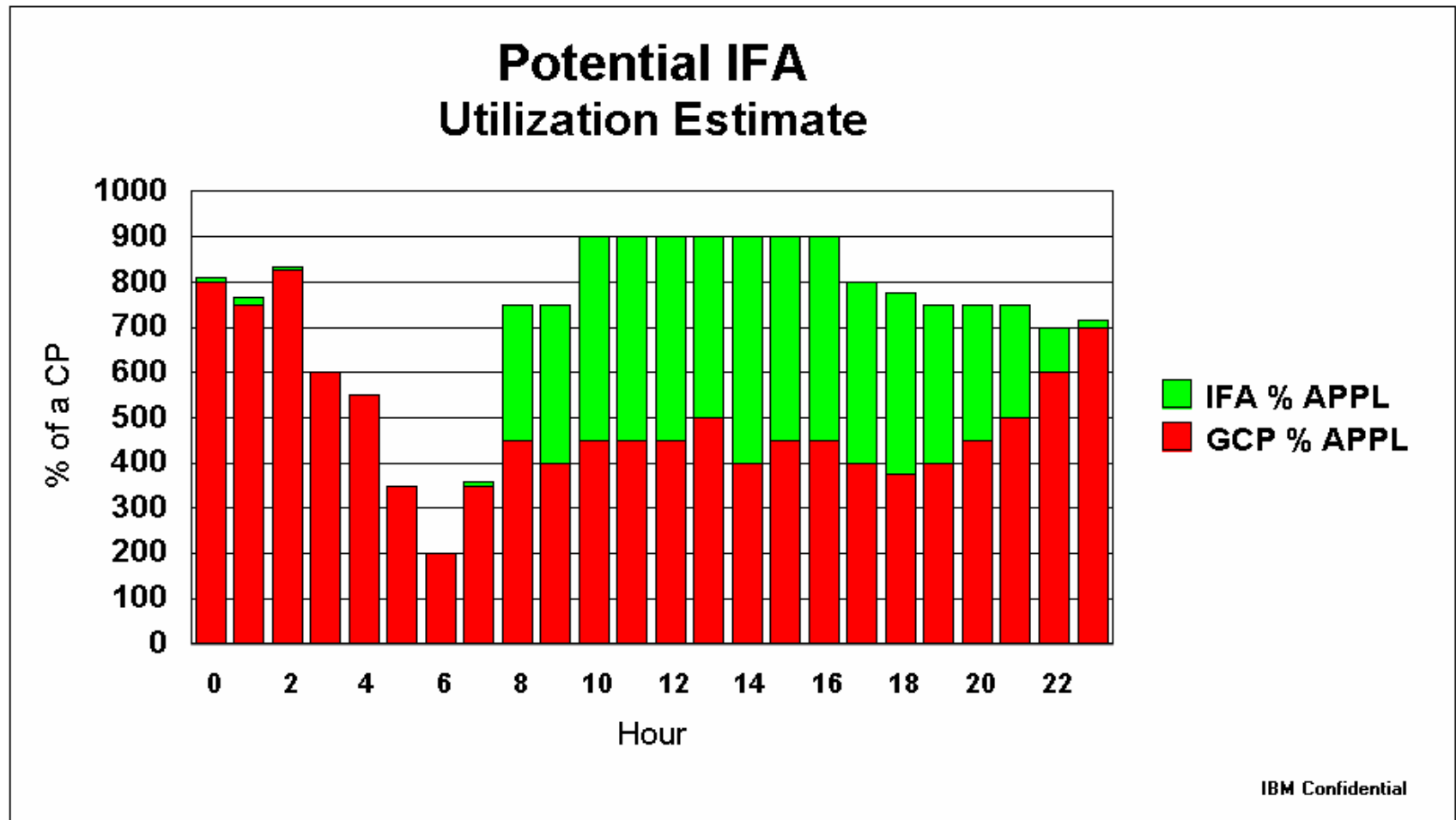

Excerpt from “z/OS Performance: Capacity Planning Considerations for zAAP Processors” White Paper (Page 10)

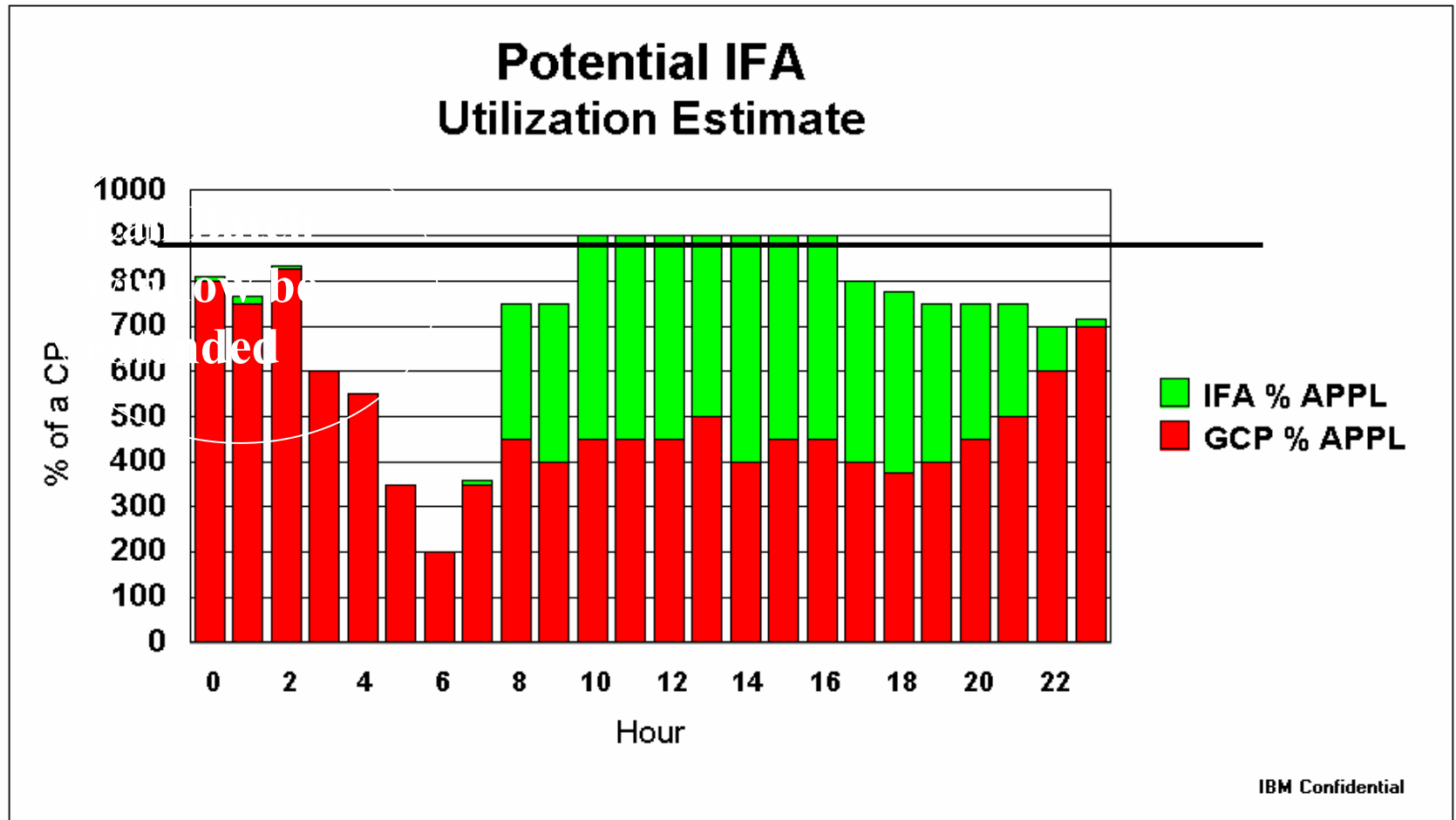

Excerpt from “z/OS Performance: Capacity Planning Considerations for zAAP Processors” White Paper (Page 7)

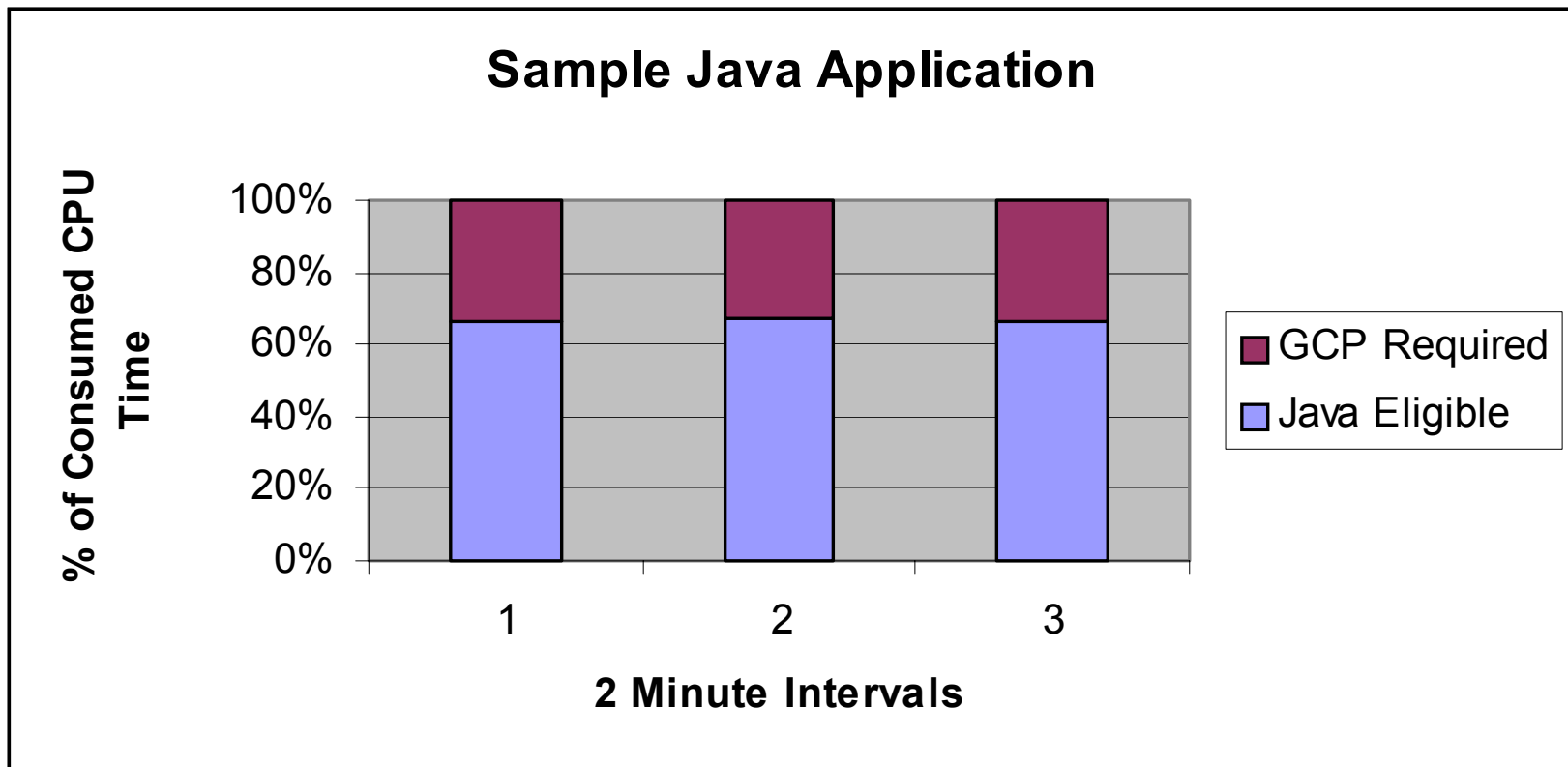

Excerpt from “z/OS Performance: Capacity Planning Considerations for zAAP Processors” White Paper (Page 8)

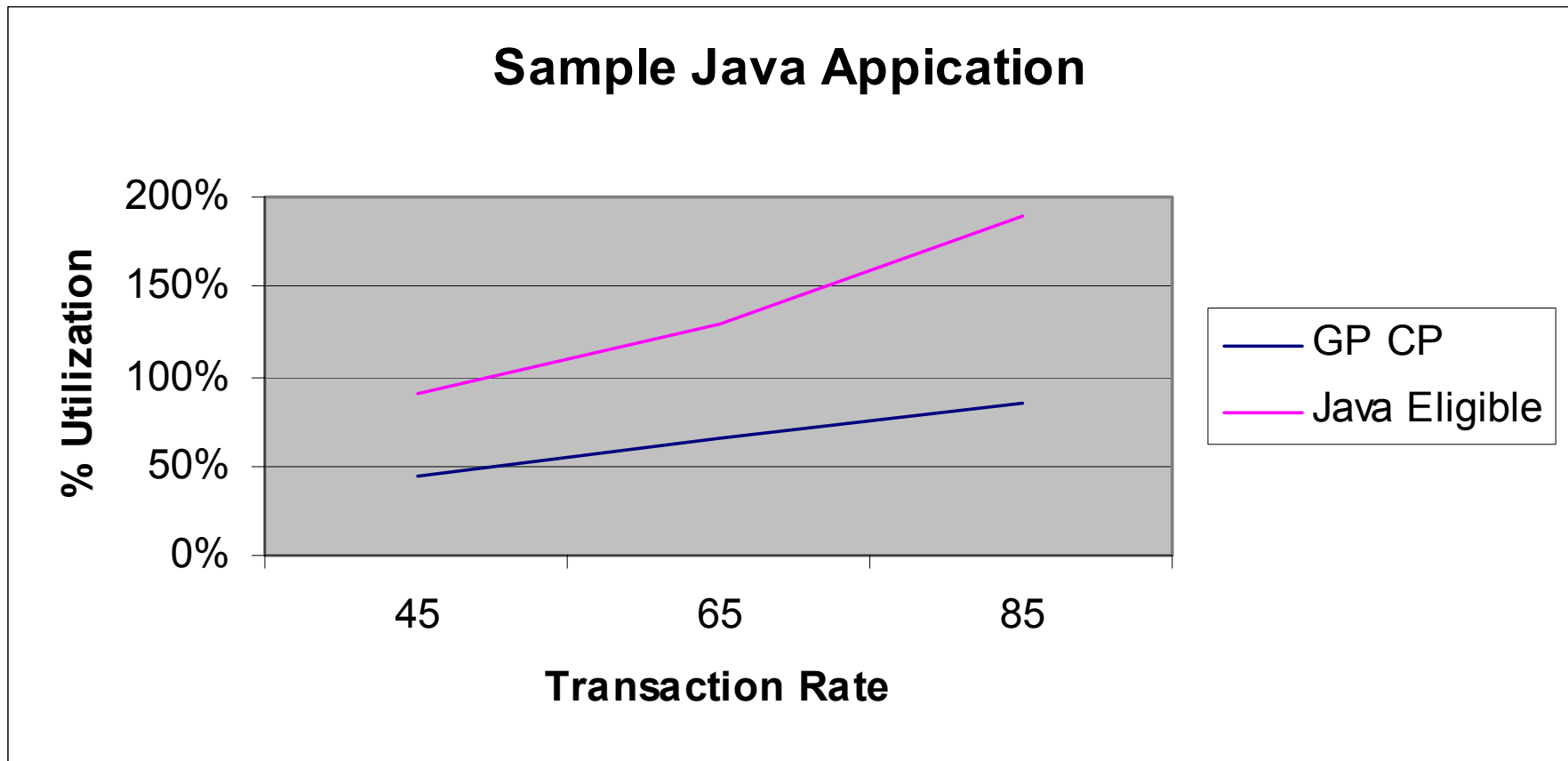

WebSphere and zAAP Innovation Driving Enhanced Integration Start Today!

WebSphere Application Server on zAAP (Application Assist Processor)

- Optimized for a new zSeries hardware processor delivering high levels of availability, reliability, flexibility, and scalability for WebSphere

- Improve total cost of ownership
Allows deployment of java workloads on a dedicated engine with no additional application software or operating system costs

- WebSphere & zAAP Special Pricing
 - Minimally 20VU WAS
 - Minimally 2 seats WSED
 - Minimally 1 zAAP



IBM eServer™

Special Programs & Offers

Michael Dickson
zSeries Marketing Manager
dicksonm@us.ibm.com

Special Programs & Offers

- **zAAP & WebSphere Solution Bundle Offeringok,**
- **zAAP Test Environment for ISVs**
- **Interim zAAP Offering**
- **zSeries Business Integration Workshops**
- **zSeries Web-enablement Workshops**
- **TCONow! Tool for zAAP Cost Analysis (by CIOView Corp)**

zAAP Summary

zSeries Application Assist Processors can help enable effective integration of Web applications with mission critical workloads for high performance at an affordable cost.

- **Help improve standard CP and system productivity**
 - zAAPs can reduce the standard processor capacity requirements for Java based applications which may free up capacity for other workload requirements
- **Help simplify and reduce server infrastructures and improve operational efficiencies**
 - Integrate your e-business Web applications with your mission-critical database workloads and help meet the e-business requirements for high performance, reliability, availability, and security
 - Help reduce hardware latency as might be seen in a Network / Distributed Web Application environment
- **zAAPs deliver investment flexibility with significant TCA savings**
 - Reduced need for Networking hardware versus what might be required in a distributed environment
 - Low Acquisition Cost and Operating Cost (\$125K USD per zAAP)
 - zAAPs do not carry a rated capacity; do not effect MSU rating of system or model designation.
 - No additional IBM software charges on zAAPs



BEFORE

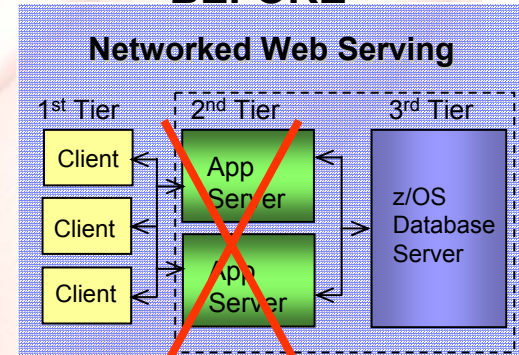

AFTER

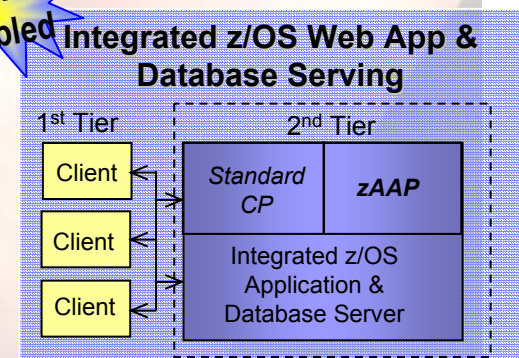

Sources of Information

Questions for today's speakers Mike Dickson Les Wyman Bob Creedon	dicksonm@us.ibm.com lwyman@us.ibm.com rcreedon@us.ibm.com
Replay of this Event (available until July 26, 2005)	800.964.4326 or 402.280.9271
IBM zAAP site	www.ibm.com/zseries/zaap
Performance White Paper	http://www-1.ibm.com/support/techdocs/atmastr.nsf/WebIndex/WP100417
zAAP Information Pack	https://www-1.ibm.com/servers/eserver/zseries/offers/zaappack/register/thankyou.html
Techdoc WP100431 Installing zAAP Projection tool	http://www-1.ibm.com/support/techdocs/atmastr.nsf/WebIndex/WP100431



IBM eServer™

Thank you

Questions?



IBM eServer™

Backup Materials

zAAP Enablement Resources

- ❖ Performance White Paper
 - <http://www-1.ibm.com/support/techdocs/atmastr.nsf/WebIndex/WP100417>
- ❖ Techdoc WP100431 Installing zAAP Projection too
 - <http://www-1.ibm.com/support/techdocs/atmastr.nsf/WebIndex/WP100431>
- ❖ IBM Redbook on zAAP: SG24-6386
- ❖ IBM zAAP site
 - ibm.com/zseries/zaap
 - Frequently Asked Questions
 - Customer Brochure
- ❖ z990 Latest Enhancements [Announcement Letter \(104-118\)](#).
- ❖ z890 [Announcement Letter \(104-117\)](#).

zAAP Test Environment for ISVs

To help enable applications running on the zAAP processor, "IBM will offer a complimentary access to a remote system at no charge.

- To qualify for the program, the ISV must be an IBM Partnerworld Member with a zAAP project profile
- The ISV will receive access to a zOS 1.6 system with Websphere and Java as well as DB2 and our IBM Software
- ISVs interested in a zAAP Test environment should send an email to : **etpadmin@us.ibm.com**

Accelerate WebSphere Application Server and zAAP Deployment Special Offering

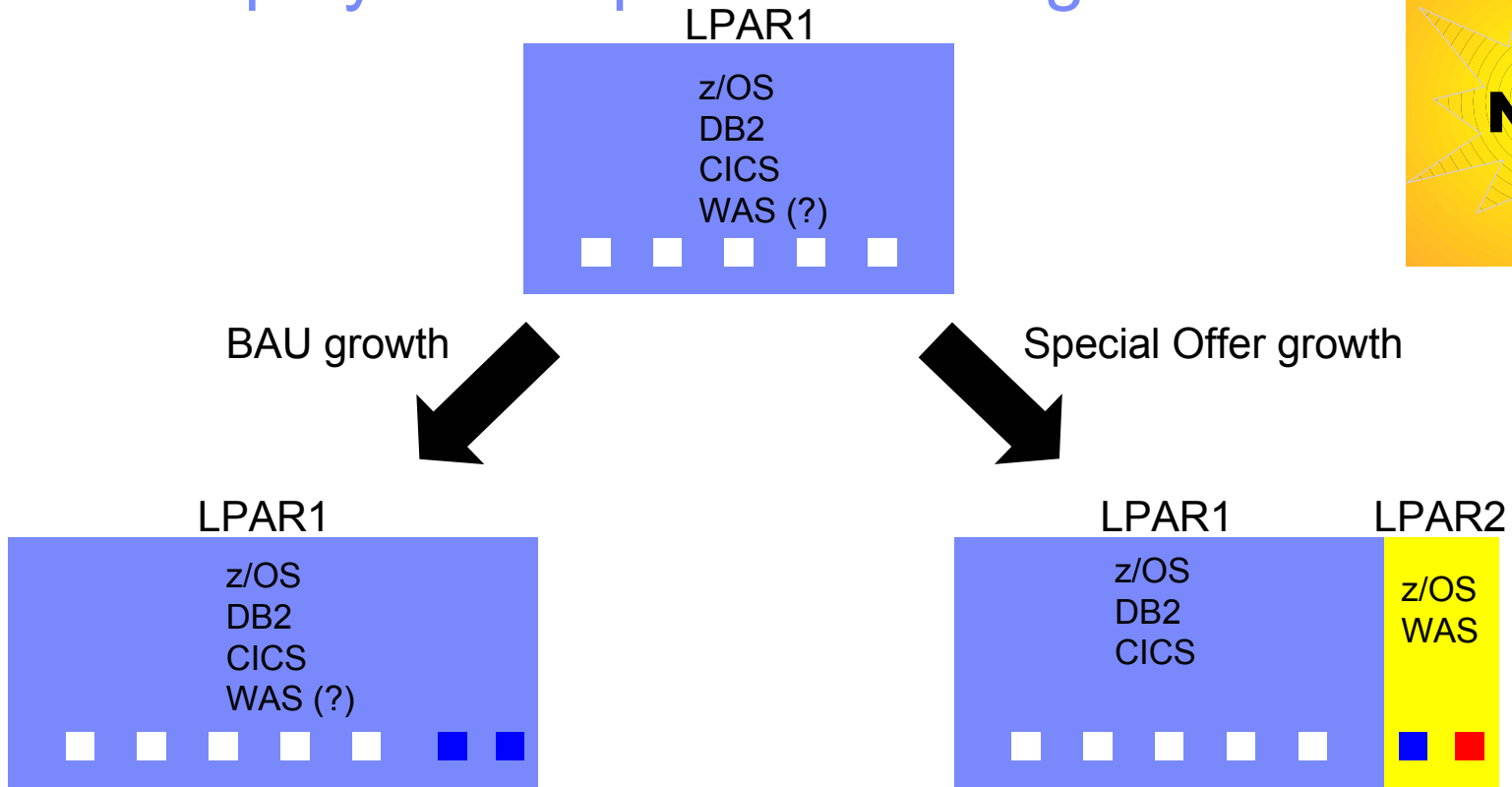

- New engines at BAU price
- All SW growth at BUA price

- 'zAAP' engine for \$125K
- z/OS for LPAR2 at NALC price

Special Terms and Conditions apply and are subject to change without notice. Contact your local IBM or authorized business partner hardware sales specialist for more information



Next Step: Are You Integration Ready?

Let us provide a free on-site Business Integration Architecture Workshop

We will work with you to evaluate your current business integration architecture

The workshop will focus on how IT can help solve your business problems

IBM will deliver a documented, high-level solution architecture and a recommended implementation roadmap

Let's get started solving your business integration challenges!

