



Installing and Configuring DB2 Connect Servers
Updated November, 2009

Note

Before using this information and the product it supports, read the general information under Appendix B, "Notices," on page 133.

Edition Notice

This document contains proprietary information of IBM. It is provided under a license agreement and is protected by copyright law. The information contained in this publication does not include any product warranties, and any statements provided in this manual should not be interpreted as such.

You can order IBM publications online or through your local IBM representative.

- To order publications online, go to the IBM Publications Center at www.ibm.com/shop/publications/order
- To find your local IBM representative, go to the IBM Directory of Worldwide Contacts at www.ibm.com/planetwide

To order DB2 publications from DB2 Marketing and Sales in the United States or Canada, call 1-800-IBM-4YOU (426-4968).

When you send information to IBM, you grant IBM a nonexclusive right to use or distribute the information in any way it believes appropriate without incurring any obligation to you.

© Copyright International Business Machines Corporation 1993, 2009.

US Government Users Restricted Rights – Use, duplication or disclosure restricted by GSA ADP Schedule Contract with IBM Corp.

Contents

Part 1. About this book 1

Part 2. Introduction to DB2 Connect 3

Chapter 1. About DB2 Connect 5

DB2 Connect product offerings 5

IBM i and mainframe support for DB2 Connect. . . . 5

Chapter 2. Common DB2 Connect scenarios 7

Access DB2 data from remote clients 7

Accessing DB2 host data from the web using Java . . 7

Accessing IBM mainframe DB2 data using DB2

Connect 8

Managing connections to databases using the

Configuration Assistant (Linux and Windows). . . 13

Understanding the Administration Server 14

Administering local and remote instances and

databases with the DB2 administration tools

(available on Linux and Windows) 14

IBM Data Server Client support for database

application development 16

Part 3. Migrating DB2 Connect . . . 19

Chapter 3. Upgrading to the latest version of DB2 Connect 21

Upgrade essentials for DB2 Connect 22

Pre-upgrade tasks for DB2 Connect servers. . . . 23

Upgrading DB2 Connect servers 24

Post-upgrade tasks for DB2 Connect servers . . . 26

Part 4. Preinstallation tasks 29

Chapter 4. Java software support for DB2 products 31

Chapter 5. Kernel parameters (Linux and UNIX) 35

Modifying kernel parameters (HP-UX) 35

Recommended kernel configuration parameters

(HP-UX) 35

Modifying kernel parameters (Linux). 35

Modifying kernel parameters (Solaris Operating

System). 37

Part 5. Installation and configuration tasks 39

Chapter 6. DB2 Connect server products: installation and configuration overview 41

Chapter 7. Disk and memory requirements 43

Chapter 8. Installing a DB2 Connect server product (AIX) 45

Installation requirements for DB2 Connect server

products (AIX) 47

Mounting CDs or DVDs (AIX) 48

Chapter 9. Installing a DB2 Connect server product (HP-UX) 51

Installation requirements for DB2 Connect server

products (HP-UX) 53

Mounting CDs or DVDs (HP-UX) 53

Chapter 10. Installing a DB2 Connect server product (Linux) 55

Installation requirements for DB2 Connect server

products (Linux). 57

Preparing to install DB2 for Linux on zSeries . . . 57

Mounting the CD or DVD (Linux). 58

Chapter 11. Installing a DB2 Connect server product (Solaris Operating System) 59

Installation requirements for DB2 Connect products

(Solaris) 61

Mounting CDs or DVDs (Solaris Operating System) 62

Chapter 12. Installing a DB2 Connect server product (Windows) 63

Installation requirements for DB2 Connect server

products (Windows) 64

Required user accounts for installation of DB2

server products (Windows) 65

Extending the Active Directory Schema for LDAP

directory services (Windows) 68

Non-Administrator installation of DB2 Connect

(Windows). 68

Adding your user ID to the DB2ADMNS and

DB2USERS user groups (Windows) 69

Chapter 13. Non-root installation overview (Linux and UNIX) 71

Differences between root installations and non-root

installations 71

Limitations of non-root installations 72

Installing a DB2 product as a non-root user. . . . 74

Enabling root-based features in non-root installations with db2rfe	76
Applying fix packs to a non-root installation	77
Removing non-root DB2 products using db2_deinstall (Linux and UNIX)	78

Part 6. Postinstallation tasks 79

Chapter 14. License key activation. 81

DB2 license files	81
Using the License Center	83
Registering a DB2 database product or feature license key using the License Center	83
Setting the DB2 license policy using the License Center	84
Using the db2licm command	85
Registering a DB2 product or feature license key using the db2licm command.	85
Setting the DB2 license policy using the db2licm command	85

Chapter 15. Applying fix packs 87

Chapter 16. DB2 Connect product installation requirements for host and midrange systems. 91

Part 7. Preparing communications and access to host and iSeries databases. 93

Chapter 17. Preparing DB2 for IBM i for connections from DB2 Connect 95

Chapter 18. Preparing DB2 for z/OS for connections from DB2 Connect 97

Host databases	97
Configuring TCP/IP for DB2 for z/OS	98
Configuring DB2 for z/OS	100

Chapter 19. Preparing DB2 for VSE & VM for connections from DB2 Connect. 101

Chapter 20. Configuring connections to mainframe and midrange servers . 103

Configuring a connection to IBM mainframe database servers using the CA (Linux and Windows)	103
Configuring a connection to IBM mainframe database servers using the CLP	104

Part 8. Reference 105

Chapter 21. Configuring access to IBM mainframe databases 107

Configuring a database connection by searching the network using the Configuration Assistant	107
Configuring a database connection manually using the Configuration Assistant.	108
Testing a database connection using the Configuration Assistant	109
Removing a DCS (host database).	109

Chapter 22. Supported DB2 interface languages 111

Displaying the DB2 Setup wizard in your national language (Linux and UNIX)	111
Language identifiers for running the DB2 Setup wizard in another language.	111
Changing the DB2 product interface language (Windows)	112
Changing the DB2 interface language (Linux and UNIX).	113
Conversion of character data	114

Chapter 23. Developing database applications 115

Binding database utilities on DB2 Connect.	115
Running your own applications	116

Chapter 24. Uninstalling DB2 Connect 119

Uninstalling your DB2 product (Windows)	119
Uninstalling your DB2 product (Linux and UNIX)	120

Part 9. Appendixes 121

Appendix A. Overview of the DB2 technical information 123

DB2 technical library in hardcopy or PDF format	123
Ordering printed DB2 books	126
Displaying SQL state help from the command line processor.	127
Accessing different versions of the DB2 Information Center	127
Displaying topics in your preferred language in the DB2 Information Center.	127
Updating the DB2 Information Center installed on your computer or intranet server.	128
Manually updating the DB2 Information Center installed on your computer or intranet server	129
DB2 tutorials	131
DB2 troubleshooting information.	131
Terms and Conditions	132

Appendix B. Notices 133

Index 137

Part 1. About this book

The *Installing and Configuring DB2 Connect Servers* provides all the information you need to prepare for and then install the DB2 Connect™ Servers product. Information specific to each supported operating system is included. The relationship between DB2 Connect Servers and the supported database server products is presented including how to configure connections.

Who should use this book?

System administrators, database administrators, communications specialists, and software product installers would all be interested in part or all of this book.

Part 2. Introduction to DB2 Connect

Chapter 1. About DB2 Connect

DB2 Connect provides connectivity to mainframe and midrange databases from Linux[®], UNIX[®], and Windows[®] operating systems. You can connect to DB2[®] databases on z/OS[®], IBM[®] i and IBM Power Systems[™], VSE, and VM. You can also connect to non-IBM databases that comply with the Distributed Relational Database Architecture[™] (DRDA[®]).

DB2 Connect product offerings

DB2 Connect has several connection solutions, including DB2 Connect Personal Edition, and a number of DB2 Connect server products.

- DB2 Connect Enterprise Edition
- DB2 Connect Application Server Edition
- DB2 Connect Unlimited Edition for System z[®]
- DB2 Connect Unlimited Edition for System i[®]

For detailed information about DB2 Connect product offerings, see www.ibm.com/software/data/db2/db2connect/

IBM i and mainframe support for DB2 Connect

Before you access DB2 data on System z or IBM i data servers using DB2 Connect products, ensure that the data server meets the necessary requirements.

DB2 Connect supports connectivity to the following System z and IBM i data servers:

Table 1. Supported System z and IBM i data servers

Version	Recommended maintenance levels
DB2 for z/OS Version 8 and Version 9	Refer to http://www.ibm.com/servers/eserver/zseries/zos/servicetst/ . In general, IBM recommends the installation of the most recent RSU (Recommended Service Upgrade) to avoid encountering problems caused by software defects already known and corrected by IBM.
DB2 for i (formerly known as DB2 UDB for i5/OS [®]) V5R3, and V5R4	II13348 (Informational APAR) For System i Preventative Service Planning, see http://www-912.ibm.com/s_dir/sline003.NSF/GroupPTFs?OpenView&view=GroupPTFs
DB2 for i V6R1	PTFs: SI30564, SI30588, SI30611, SI30620, SI30621, SI30622, SI30825, SI30827, SI30920, SI30921, SI31019, SI31101, SI31125, SI31238, and SI31480. For System i Preventative Service Planning, see http://www-912.ibm.com/s_dir/sline003.NSF/GroupPTFs?OpenView&view=GroupPTFs .
DB2 Server for VM and VSE Version 7 and later	See http://www.ibm.com/software/data/db2/vse-vm/

Additional prerequisite information is available at: <http://www.ibm.com/support/docview.wss?rs=71&context=SSEPGG&dc=D600&uid=swg21233566>.

Chapter 2. Common DB2 Connect scenarios

Common ways in which DB2 Connect is used to create working database environments and common ways of completing primary tasks involving DB2 Connect are presented. The scenarios include environments and tasks such as: direct connection between DB2 Connect and IBM mainframe database server; using the Configuration Assistant to manage connections to databases; and IBM data server client support for database application development.

Access DB2 data from remote clients

The IBM data server client provides a run-time environment that enables client applications to access one or more remote databases. With the IBM data server client, you can remotely administer DB2 or DB2 Connect servers. All applications must access a database through the IBM data server client. A Java™ applet can access a remote database through a Java-enabled browser.

The IBM data server client is supported on Linux, UNIX, and Windows platforms.

Accessing DB2 host data from the web using Java

DB2 Connect products include the IBM Data Server Driver for JDBC and SQLJ to allow you to create applications that access data in DB2 databases from the Web.

Programming languages containing embedded SQL are called host languages. Java differs from the traditional host languages C, COBOL, and FORTRAN, in ways that significantly affect how it embeds SQL:

- SQLJ and JDBC are open standards, enabling you to easily port SQLJ or JDBC applications from other standards-compliant database systems to the DB2 database.
- All Java types representing composite data, and data of varying sizes, have a distinguished value, null, which can be used to represent the SQL NULL state, giving Java programs an alternative to NULL indicators that are a fixture of other host languages.
- Java is designed to support programs that, by nature, are heterogeneously portable (also called "super portable" or simply "downloadable"). Along with Java's type system of classes and interfaces, this feature enables component software. In particular, an SQLJ translator written in Java can call components that are specialized by database vendors in order to leverage existing database functions such as authorization, schema checking, type checking, transactional, and recovery capabilities, and to generate code optimized for specific databases.
- Java is designed for binary portability in heterogeneous networks, which promises to enable binary portability for database applications that use static SQL.
- You can run JDBC applets inside a web page on any system with a Java-enabled browser, regardless of the platform of your client. Your client system requires no additional software beyond this browser. The client and the server share the processing of JDBC and SQLJ applets and applications.

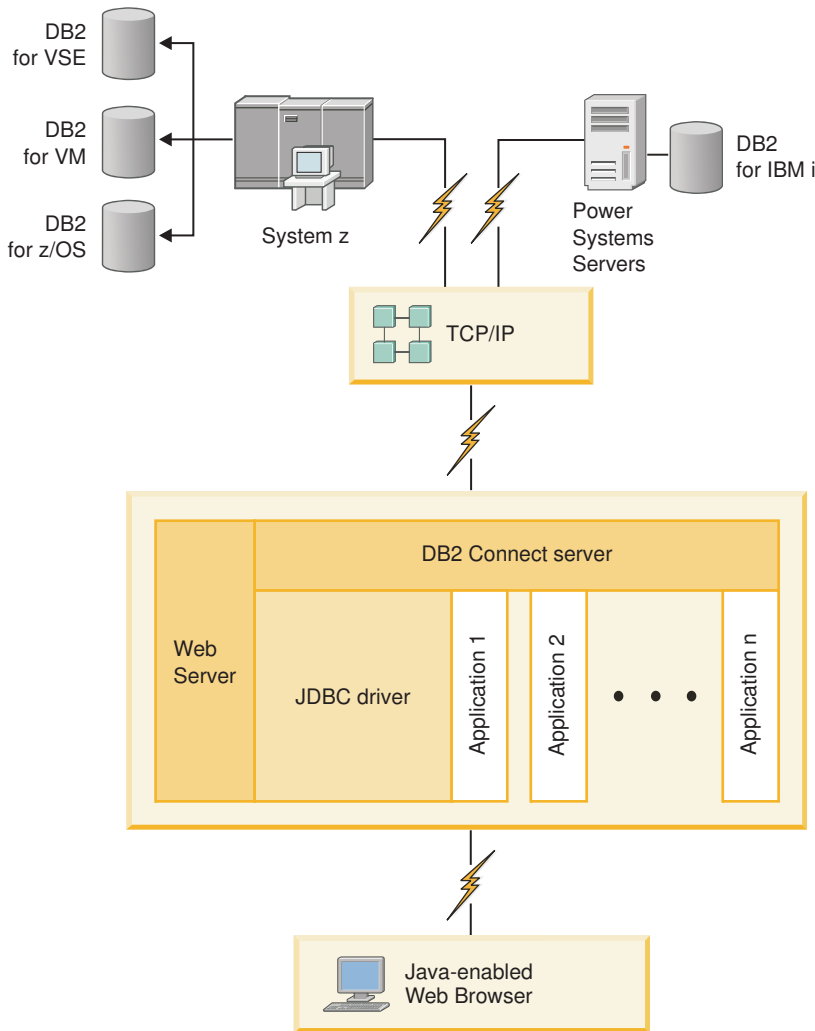

Figure 1. JDBC and DB2 Connect

JDBC and SQLJ applications can be run from any system that has a IBM data server client installed; a Web browser and a Web server are not required.

For more information on the JDBC API, see the <http://java.sun.com/products/jdbc/web> page.

Accessing IBM mainframe DB2 data using DB2 Connect

A DB2 Connect server enables a IBM data server client on a LAN access to data that is stored on IBM mainframe systems.

In organizations with large amounts of data, DB2 for IBM i, DB2 for z/OS, or DB2 Server for VM and VSE are commonly used to manage that data. Applications that run on any of the supported platforms can work with this data transparently, as if a local database server managed it. A DB2 Connect server product, such as DB2 Connect Enterprise Edition, is required for supporting applications which access IBM mainframe data and exploit transaction monitors as well as applications that are implemented as Java applets.

In addition, you can use a wide range of off-the-shelf or custom-developed database applications with DB2 Connect and its associated tools. For example, you can use DB2 Connect products with:

- *Spreadsheets*, such as Microsoft® Excel and Lotus® 1-2-3®, to analyze real-time data without having the cost and complexity of data extract and import procedures.
- *Decision support tools*, such as BusinessObjects, Brio and Impromptu, and Crystal Reports, to provide real-time information.
- *Database products*, such as Lotus Approach® and Microsoft Access.
- *Development tools*, such as PowerSoft PowerBuilder, Microsoft Visual Basic, and Borland Delphi, to create client/server solutions.

A DB2 Connect server product, such as DB2 Connect Enterprise Edition, is most appropriate for environments where:

- Application is implemented using data-aware Java applets (see Figure 1 on page 8).
- Web servers are used to implement web-based applications (see Figure 5 on page 13 and Figure 1 on page 8).
- Middle-tier application server is employed.
- Transaction monitors such as IBM TXSeries CICS®, WebSphere® Application Server, WebSphere MQ, Microsoft Transaction Server (MTS), and BEA Tuxedo are used. (See Figure 3 on page 11.)

DB2 Connect provides transparent access to IBM mainframe data through a standard architecture for managing distributed data. This standard is known as Distributed Relational Database Architecture (DRDA). DRDA allows your applications to establish a fast connection to IBM mainframe databases without expensive IBM mainframe components or proprietary gateways.

Although DB2 Connect is often installed on an intermediate server machine to connect a IBM data server client to a IBM mainframe database, it is also installed on machines where multiple local users want to access the IBM mainframe servers directly. For example, DB2 Connect can be installed on a large machine with many local users.

DB2 Connect can also be installed on a Web server, Transaction Processor (TP) monitor, or other 3-tier application server machines with multiple local SQL application processes and threads. In these cases, you can choose to install DB2 Connect on the same machine for simplicity, or on a separate machine to off-load CPU cycles.

A DB2 Connect server enables multiple clients to connect to IBM mainframe data and can significantly reduce the effort that is required to establish and maintain access to enterprise data. Figure 2 on page 10 illustrates IBM's solution for environments where a IBM data server client makes an indirect connection to a IBM mainframe database server through a DB2 Connect server product.

To connect to an IBM mainframe database server you require a licensed DB2 Connect product. You cannot connect directly to an IBM mainframe Data Server using a IBM data server client.

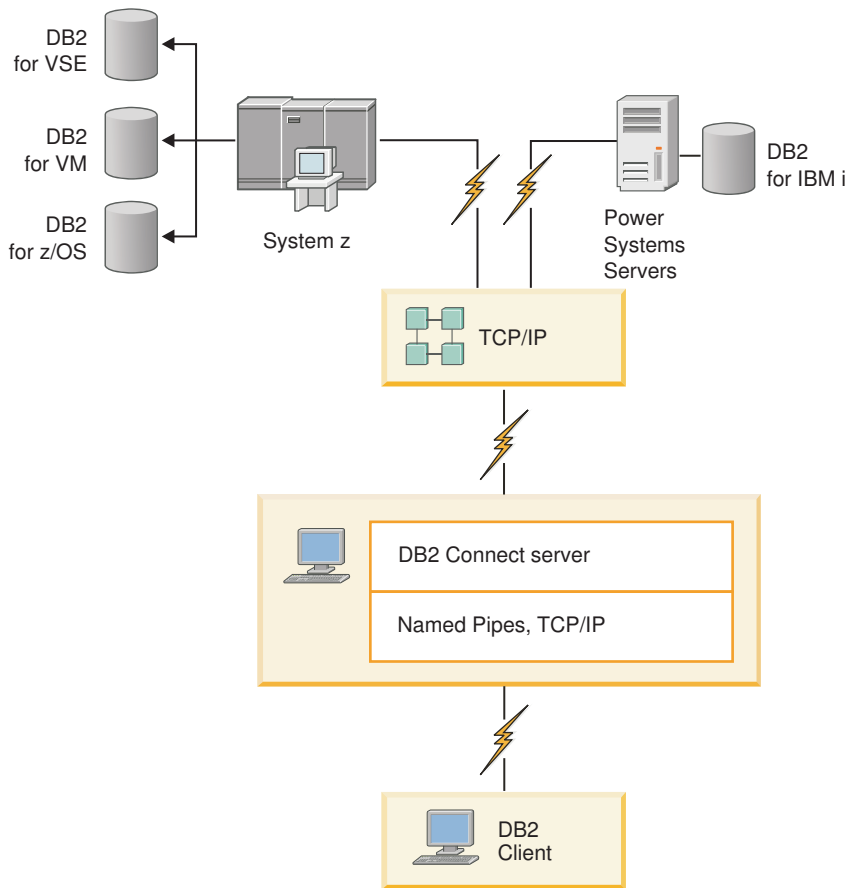

Figure 2. Connecting a client to a IBM mainframe data server using DB2 Connect

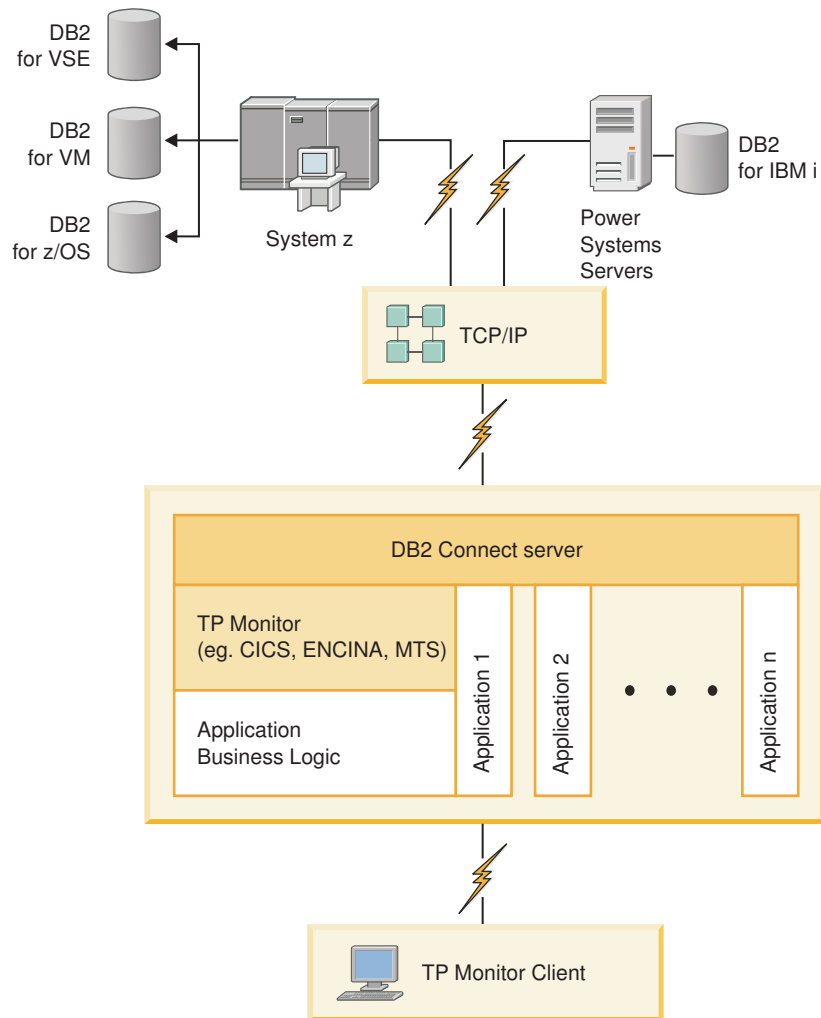

Figure 3. Transaction monitors working with DB2 Connect.

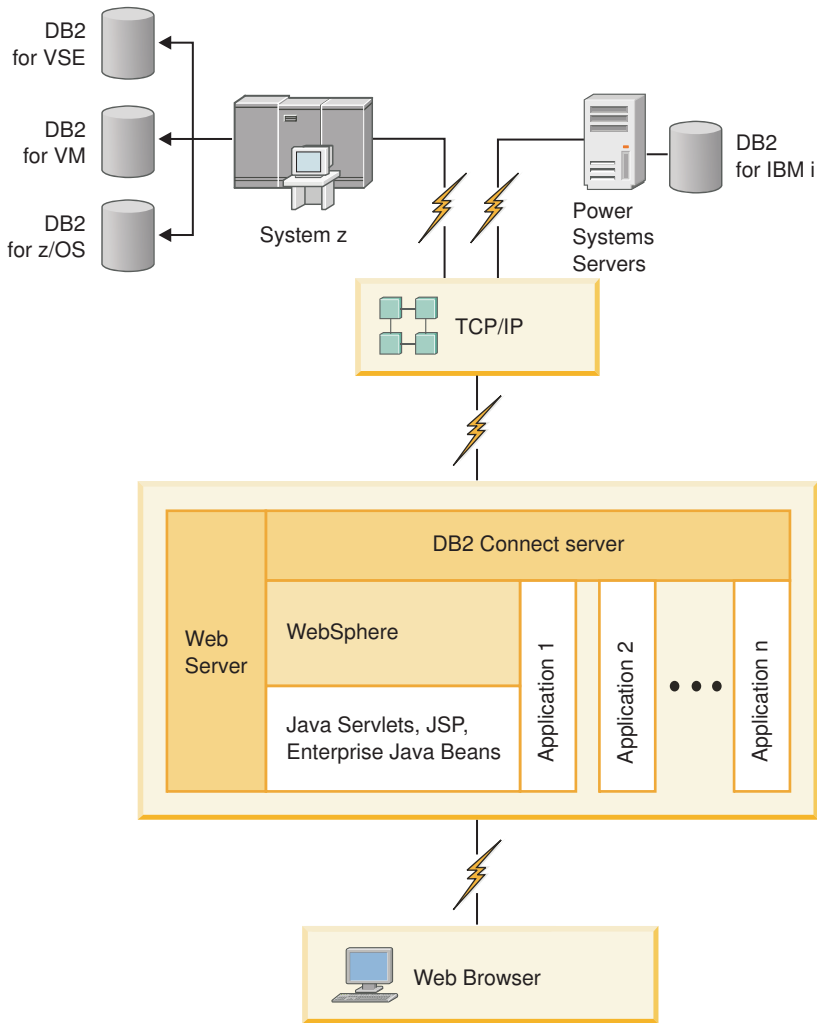

Figure 4. WebSphere and Java server functionality in DB2 Connect

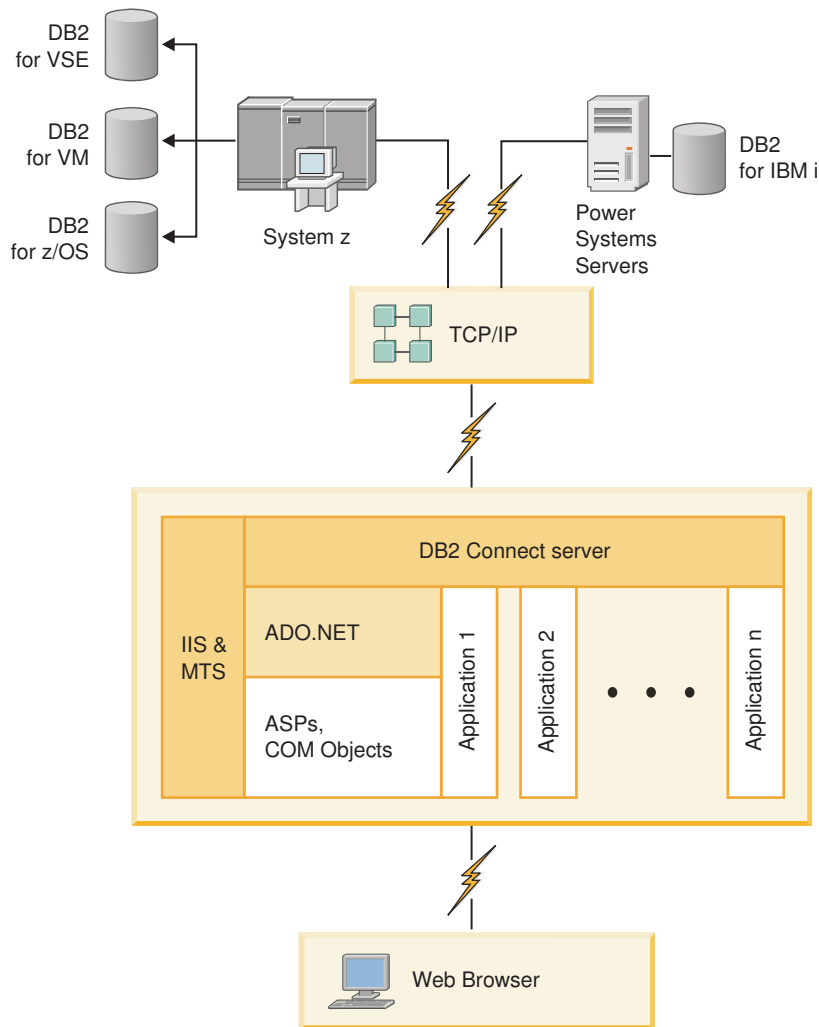

Figure 5. DB2 Connect working with Microsoft Internet Information Server (IIS)

Managing connections to databases using the Configuration Assistant (Linux and Windows)

The Configuration Assistant (CA) helps you manage your database connections to remote servers. The CA is available as part of the DB2 client. The CA is the preferred method to set up any client to server communications.

Note: In previous releases, the DB2 Administration Tools, such as the CA, were supported on all platforms. As of Version 9, the DB2 Administration Tools are supported only on Windows x86, Windows x64 (AMD64/EM64T), Linux on x86, and Linux on AMD64/EM64T. For all platforms, you can use the DB2 command line processor (CLP) to manage connections.

With the CA, you can:

- Catalog databases so that they can be used by applications. Three methods are available:
 - Use a profile provided by a database administrator to automatically define your connections. Client access is automatically set up for that database.

- Search the network for available databases and select one. Client access is automatically set up for those databases defined in the profile. DB2 Connect Personal Edition cannot search for IBM mainframe databases except through a DB2 Connect server that has IBM mainframe databases defined.
- Manually configure a connection to a database by entering the required connection parameters.
- Remove cataloged databases, or change the properties of a cataloged database.
- Export and import client profiles that contain database and configuration information for a client.
- Test connections to local or remote databases identified on your system.
- Bind applications to a database by selecting utilities or bind files from a list.
- Add, change, remove CLI/ODBC data sources, and configure CLI/ODBC configuration settings.
- Tune the client configuration parameters on your system. Parameters are logically grouped and suggested settings are provided on the interface as parameters are selected.
- Update the database server password.

Understanding the Administration Server

The DB2 Administration Server (DAS) responds to requests from the DB2 Administration Tools and the Configuration Assistant (CA). The DB2 Administration Tools, for example, allow you to start, stop, and set database manager configuration parameters for servers. The Administration Server is used by the CA to help users catalog databases on a client. The DAS is available on all supported Linux, Windows, and UNIX operating systems as well as the System z (z/OS only) operating systems.

An Administration Server must reside on each server that you want to administer and detect. The Administration Server is automatically created and started for you. The setup program creates the Administration Server on the instance-owning machine and automatically starts it at boot time. By default the DAS instance is DB2AS, which is the default user ID that is created using the DB2 Setup wizard.

Important: The DB2 Administration Server (DAS) has been deprecated in Version 9.7 and might be removed in a future release. For more information, see the “Control Center tools and DB2 administration server (DAS) have been deprecated” topic in the *What’s New for DB2 Version 9.7* book.

Administering local and remote instances and databases with the DB2 administration tools (available on Linux and Windows)

You can administer local or remote servers using the DB2 administration tools. The DB2 administration tools are used through the Control Center to perform administration tasks such as configuring DB2 instances and databases, backing up and recovering data, scheduling jobs, and managing media, all from a graphical interface.

Note: In previous releases, the DB2 Administration Tools, found as part of the Control Center, were supported on all platforms. As of Version 9, the DB2 Administration Tools are supported only on Windows x86, Windows x64

(AMD64/EM64T), Linux on x86, and Linux on AMD64/EM64T. For all platforms, you can use the DB2 command line processor (CLP) to administer instances and databases.

Important: The Control Center and its associated components have been deprecated in Version 9.7 and might be removed in a future release. For more information, see the “Control Center tools and DB2 administration server (DAS) have been deprecated” topic in the *What’s New for DB2 Version 9.7* book.

In addition to performing local administration tasks, the Control Center has support for the following remote products:

- DB2 Universal Database (UDB) for OS/390® and z/OS Version 7
- DB2 UDB for z/OS Version 8

The remainder of this topic will refer collectively to these products as DB2 for z/OS, unless the content is version specific.

If you want to access DB2 for z/OS functions from the Control Center:

1. Verify that:
 - You have a DB2 for z/OS license
 - You have a DB2 Connect product installed on the client workstation
 - Distributed Data Facility (DDF) is started at the host
 - The DB2 subsystem is cataloged on the client
 - The DB2 Connect utilities and the DB2 CLI are bound to the host
2. Apply the FMIDs for the DB2 Management Clients Package (a feature of DB2 for z/OS) and DB2 Administration Server (DAS) for OS/390 and z/OS. DAS is an optional feature that is shipped with DB2 for OS/390 and z/OS server. Read the DB2 for z/OS, DB2 Management Clients Package, and DB2 Administration Server for OS/390 and z/OS program directories. The program directory identifies and describes the contents of FMIDs for each tape or cartridge. The program directory also provides the installation requirements and instructions.
3. Apply any additional service to DB2 for z/OS as described in the program directories.
4. The DB2 Control Center provides support to help you manage DB2 databases on multiple platforms. When managing DB2 for z/OS subsystems, you need to install a set of stored procedures, user defined functions, and batch programs for each DB2 subsystem:

DB2 UDB for z/OS Version 8

If you have DB2 UDB for z/OS Version 8 installed, you need to install the z/OS enablement feature (JDB881D).

DB2 UDB for OS/390 and z/OS Version 7

If you have DB2 UDB for OS/390 and z/OS Version 7 installed, you need to install the 390 enablement feature (JDB771D).

If you want to fully exploit all the DB2 Control Center functions for DB2 for z/OS, including Cloning and JCL building and creation, you need to install the DB2 Administration Server (DAS) for OS/390 and z/OS Version 8 (HDAS810) which ships as a feature of DB2 for z/OS.

Note:

- a. FMID JDB881D or JDB771D needs to be installed on every DB2 subsystem that you want to work with using the Control Center.

- b. FMID HDAS810 needs to be installed only once per image of the operating system or LPAR where you have DB2 subsystems that you want to work with using Control Center.
 - c. Instructions for the various installations can be found in the Program Directory within the DB2 Management Clients Package of the appropriate product and version. For example, instructions for installing the DAS (HDAS810) are in the Program Directory for IBM DB2 UDB for z/OS DB2 Management Clients Package Version 8.
 - d. The DB2 Administration Server only needs to be installed once per system.
5. Ensure that you enabled the stored procedures address space.
 6. Ensure that the DB2 Administration Server is started.

Detailed instructions for enabling the Control Center to work with DB2 for z/OS exists at:

<http://www.ibm.com/support/docview.wss?rs=64&context=SSEPEK&q1=jdb881d&uid=swg27006262>

IBM Data Server Client support for database application development

The Data Server Client includes the following:

- **Precompilers for C/C++, COBOL, and Fortran**, (providing the language is supported for that platform).
- **Embedded SQL application support**, including programming libraries, include files and code samples.
- **ODBC and DB2 Call Level Interface (DB2 CLI) application support**, including programming libraries, include files, and code samples for developing applications which are easily ported to ODBC and compiled with an ODBC SDK. An ODBC SDK is available from Microsoft for Windows operating systems, and from various other vendors for many of the other supported platforms. On Windows operating systems, the ODBC and CLI driver is installed by default with the DB2 Client, supporting applications developed with the Microsoft ODBC Software Developer's Kit. For all other platforms, the ODBC and CLI driver can optionally be installed with the DB2 Client, supporting applications that can be developed with an ODBC SDK for that platform, if one exists.
- **The IBM Data Server Driver for JDBC and SQLJ**, which includes:
 - Support for JDBC 3 and JDBC 4 compliant applications
 - SQLJ support, for developing Java applications with static SQL
- **Java 5** environment is embedded in DB2 servers to support server-side Java application artifacts including stored procedures and user-defined functions
- **ActiveX Data Objects (ADO) and Object Linking and Embedding (OLE) automation routines (UDFs and Stored Procedures)** on Windows operating systems, including code samples implemented in Microsoft Visual Basic and Microsoft Visual C++.
- **Object Linking and Embedding Database (OLE DB) table functions** on Windows operating systems.
- **C# and Visual Basic .NET applications and CLR .NET routines** on Windows operating systems.
- **Ruby and Ruby on Rails application support**, including IBM_DB gem for easy install and code samples. Ruby is a fully-integrated object-oriented programming

language used to develop web applications. Ruby on Rails (RoR), also known as Rails, is a framework for developing web applications that access databases according to the Model-View-Control architectural framework

- **PHP Hypertext Preprocessor application support** , including programming libraries and code samples. PHP is a scripting language used to develop web applications. It also supports object-oriented programming
- **IBM Data Studio** is a comprehensive suite of integrated Eclipse tools for the database developer and development DBA. IBM Data Studio reduces the time to perform day-to-day administration tasks, create, deploy, and debug SQL and Java stored procedures, deploy data-centric web services, and create queries for relational and XML data using SQL and XQuery for DB2 and Informix® data servers.
- **Interactive SQL** through the Command Editor or Command Line Processor (CLP) to prototype SQL statements or to perform ad hoc queries against the database.
- **A set of documented APIs** to enable other application development tools to implement precompiler support for DB2 directly within their products. For example, IBM COBOL on AIX® uses this interface.

Part 3. Migrating DB2 Connect

Chapter 3. Upgrading to the latest version of DB2 Connect

Upgrading to a new version or release of DB2 Connect might require upgrading your environment components if you want them to run on the new release. These components are DB2 Connect servers, DB2 servers, DB2 clients, and database applications.

For example, if you have an existing environment using an earlier version or release of DB2 Connect and you want to install the latest version or release of DB2 Connect, then you can upgrade your DB2 Connect server and you might need to upgrade other components in your environment.

DB2 Connect servers supports the upgrading of DB2 Connect instances, and any existing transaction manager and DB2 Connect federated databases created on previous versions of DB2 Connect servers. For DB2 Connect releases prior to DB2 Connect Version 8, you need to migrate first to DB2 Connect Version 8, and then upgrade to the latest version or release of DB2 Connect. Refer to migrating from previous versions of DB2 Connect for details on how to migrate to DB2 Universal Database (UDB) Version 8.

The upgrade process consists of all the tasks that you need to perform to have your environment running successfully on a new release. The upgrading of each of the components in your environment to the latest version or release of DB2 Connect requires that you perform different tasks:

- Upgrading DB2 Connect servers involves upgrading your existing instances, any existing DB2 Connect federated databases, and any existing transaction manager databases so that they can run in the latest version or release of DB2 Connect.
- Upgrade your existing instances and databases so that they can run in the latest version or release of the DB2 products. Refer to the Upgrading DB2 servers topic in the *Upgrading to DB2 Version 9.7*.
- Upgrade your client instances to keep the configuration of your existing DB2 clients. Refer to the Upgrading clients topic in the *Upgrading to DB2 Version 9.7*.
- Upgrading database applications involves testing them in the latest version or release of DB2 Connect and modifying them only when you need to support changes available in the latest version or release of DB2 Connect. Review changes in existing functionality and discontinued and deprecated functionality for DB2 Connect in the What's New for DB2 Version 9.7 to determine the changes that could impact your database applications. If your database applications connect to DB2 servers, review also the Database applications and routines upgrade topic in the *Upgrading to DB2 Version 9.7*.

The best approach to upgrading is to write an upgrade plan. A strategy defines how to approach the upgrading of your environment and gives you the outline for your upgrade plan. The characteristics of your environment and the information in upgrade essentials, especially the upgrade recommendations and restrictions, can help you determine your strategy. An upgrade plan should include the following upgrade details for each component:

- Upgrade prerequisites that indicate all the requirements that you need to meet before upgrading.
- Pre-upgrade tasks which describe all the preparation tasks that you need to perform before upgrading.

- Upgrade tasks which describe step by step the basic upgrade process for a component and how to upgrade environments with special characteristics.
- Post-upgrade tasks which describe all the tasks that you need perform after upgrading to have your DB2 server running at the optimum level.

You will find that pre-upgrade tasks, upgrading tasks, and post-upgrade tasks for DB2 Connect servers reference pre-upgrade tasks, upgrading tasks, and post-upgrade tasks for DB2 servers because they are exactly the same tasks.

Upgrade essentials for DB2 Connect

If you are upgrading your clients to the latest version or release of DB2 Connect, you need to consider the following changes in support and resolve them before you upgrade:

Authentication type specified in the database directory entry at the gateway overrides the authentication type cataloged at the client

If you are upgrading from a release prior to DB2 Connect Version 8.2.2 (equivalent to Version 8.1 FixPak 9) to the latest version or release, ensure that the authentication type at the gateway is compatible with the client and the server. If you did not specify an authentication type in the database directory entry at the gateway, the default authentication type is SERVER.

DB2 Connect Server and DB2 Connect Personal Edition no longer supports SNA protocol

If you are upgrading from a release prior to DB2 Connect Version 9.1, you need to re-catalog all nodes that use SNA protocol to use TCP/IP protocol instead.

Upgrade essentials for DB2 servers and clients also apply to DB2 Connect servers

Upgrade support and restrictions for DB2 servers and clients also apply when you upgrade your DB2 Connect server.

- Review the “upgrade essentials for DB2 servers” topic in *Upgrading to DB2 Version 9.7* to determine additional changes that impact your upgrade and how to address any issues.
- Review the “upgrade essentials for clients” topic in *Upgrading to DB2 Version 9.7*, especially Connectivity support between clients and DB2 servers. Connections to the latest version or release of DB2 Connect servers from a client release two or more versions earlier are not supported.

New names and packaging of the DB2 components

In DB2 Version 9.7, the names and packaging of the DB2 components have been changed. Refer to the “Component names have changed” topic in the *What’s New for DB2 Version 9.7* for details on the new names and generic client names.

Upgrade recommendations for DB2 Connect

In general, the recommendation is to upgrade DB2 Connect servers first and then clients. The last two versions of the clients can connect to the latest version or release of DB2 Connect servers. The only restriction is that new features are not available to the clients from the previous versions and releases. However, it is not likely that you need access to these new features because your existing applications do not use them.

If you choose to upgrade your clients first, you need to be aware that there are known limitations about the support for connectivity from a current version or release of the client to DB2 Connect servers from two versions ago. Check the current version or release of the incompatibilities with previous releases, see if these limitations apply to your application in order to take necessary actions.

Perform the pre- and post-upgrade tasks to ensure a successful upgrade.

Pre-upgrade tasks for DB2 Connect servers

To successfully upgrade your DB2 Connect servers, preparation is required to address any issues that may exist.

Perform the following pre-upgrade tasks for DB2 servers that also apply to DB2 Connect servers:

1. Review the “Upgrade essentials for DB2 Connect” on page 22 to identify the changes or restrictions that can affect your upgrade and learn how to address any issues prior to upgrading.
2. Refer to the “Backing up DB2 server configuration and diagnostic information” topic in *Upgrading to DB2 Version 9.7* to have a record of your current configuration that you can compare with the configuration after the upgrade. You can also use this information to create new instances or databases using the same configuration that you had before upgrading.
3. Optional: If you enabled the Syncpoint Manager (SPM) functionality on your DB2 Connect server, ensure that the DRDA sync point managers do not contain any indoubt transactions by using the “LIST DRDA INDOUBT TRANSACTIONS command” in the *Command Reference* to get a list of indoubt transactions and to interactively resolve any indoubt transactions.
4. Optional: If you have transaction manager databases, perform the following pre-upgrade tasks to prepare your databases for upgrading:
 - a. Ensure that the database to be upgraded does not contain any indoubt transactions by using the “LIST INDOUBT TRANSACTIONS command” in the *Command Reference* to get a list of indoubt transactions and to interactively resolve any indoubt transactions.
 - b. Refer to the “Verify that your databases are ready for upgrading” topic in the *Upgrading to DB2 Version 9.7* to identify and resolve any problems before the actual upgrade.
 - c. Refer to the “Backing up databases before upgrading” topic in the *Upgrading to DB2 Version 9.7* to be able to upgrade them to a new upgraded system or restore them in the original pre-upgrade system.
 - d. Review the “disk space requirements” topic in the *Upgrading to DB2 Version 9.7* to ensure that you have enough free disk space, temporary table space and log space for database upgrading and the “Increasing table space and log file sizes before upgrading” topic in the *Upgrading to DB2 Version 9.7* if necessary.
 - e. Linux only: “Changing raw devices to block devices (Linux)” topic in the *Upgrading to DB2 Version 9.7*
5. Optional: If you have DB2 Connect federated databases, refer to the “Preparing to migrate to federated systems” topic in the *IBM WebSphere Information Integration: Migrating to Federation Version 9* for details on pre-upgrade tasks for these databases.

6. Windows only: If you obtained customized code page conversion tables from the DB2 support service, you need to backup all of the files in the DB2OLD\conv directory where DB2OLD is the location of your existing DB2 Connect copy. Upgrading your current version or release of DB2 Connect copy removes these tables because standard code page tables are contained in a new version or release DB2 Connect library. You do not need to backup standard code page conversion tables.
7. Optional: Upgrade your DB2 Connect server in a test environment to identify upgrade issues and to verify that database applications and routines work as expected before upgrading your production environment.
8. In the latest version or release of DB2 Connect, all significant upgrade events are logged in the db2diag log files when the **diaglevel** database manager configuration parameter is set to 3 (default value) or higher. If this parameter is set to 2 or less, refer to the “Setting the diagnostic log file error capture level” topic in the *Troubleshooting and Tuning Database Performance* to set this parameter to 3 or higher before upgrading.
9. Take the DB2 Connect server offline for upgrading. For details, refer to the “Taking a DB2 server offline before upgrading” topic in the *Upgrading to DB2 Version 9.7*

Upgrading DB2 Connect servers

The latest version or release of DB2 Connect servers supports the upgrade of DB2 Connect instances, and any existing transaction manager and DB2 Connect federated databases created on the two previously supported versions of DB2 Connect servers.

Since DB2 Connect server products are host database connectivity servers, the only databases that can exist within a DB2 Connect server instance are transaction manager databases and DB2 Connect federated databases. The DB2 Connect transaction manager database stores transaction state information for DB2 coordinated transactions. The sole purpose of DB2 Connect federated databases is to contain information about data sources.

On Linux and UNIX platforms, you should manually upgrade your DB2 Connect instances after installing the latest version of DB2 Connect. All the remote nodes and databases that you cataloged on the DB2 clients refer to these instances. If you create a new instance, again you will have to catalog nodes, DCS databases, and databases on the DB2 clients that existed in the instances from the previous version.

On Windows operating systems, you have an option to automatically upgrade an existing, supported DB2 Connect copy during installation. Your DB2 Connect instances are automatically upgraded. Alternatively, you can install a new copy of the latest version of DB2 Connect and then manually upgrade your DB2 Connect instances.

This procedure describes how to upgrade by installing a new copy of the latest version of DB2 Connect and then upgrade instances and any existing databases. To automatically upgrade an existing, supported DB2 Connect copy on Windows, follow the same steps specified in the “Upgrading a DB2 server (Windows)” topic in the *Upgrading to DB2 Version 9.7*.

Prerequisites

Before upgrading to the latest version of DB2 Connect:

- Ensure that you have the proper operating system access:
 - Root access on UNIX
 - Local Administrator on Windows
- Ensure that you have SYSADM authority.
- Ensure that you meet the requirements given in the “Installation requirements for DB2 database products” topic in the *Installing DB2 Servers*. The requirements for Linux and UNIX operating systems have changed.
- Review the “Best practices for upgrading DB2 servers” topic in the *Upgrading to DB2 Version 9.7*.
- Review the “Disk space requirements for DB2 server upgrades” topic in the *Upgrading to DB2 Version 9.7*.
- Perform the pre-upgrade tasks, especially backup your databases.

Restrictions

- The bit size of the client instance is determined by the operating system where you install DB2 Connect. Refer to the “Support changes for 32-bit and 64-bit DB2 servers” topic in the *Upgrading to DB2 Version 9.7* for details.
- Additional upgrade restrictions found in the “Upgrade restrictions for DB2 servers” topic in the *Upgrading to DB2 Version 9.7* also apply to DB2 Connect servers.

If you have DB2 Connect Version 7, you must migrate to DB2 Connect Version 8 first. Refer to the following topic for details: <http://publib.boulder.ibm.com/infocenter/db2luw/v8/topic/com.ibm.db2.udb.doc/conn/t0008566.htm>

To upgrade your DB2 Connect server:

1. Export your connectivity configuration information for your existing, supported DB2 Connect server to an export profile. Use the `db2cfexp` tool to create a configuration profile:

```
$ db2cfexp cfg_profile backup
```

This profile contains all of the instance configuration information, including the database manager configuration and registry profile because the option `backup` is specified. You can use this profile to recreate your connectivity configuration if necessary.

2. Install DB2 Connect by running the DB2 Setup wizard and select the option Install New on the Install a Product panel.
3. Refer to the “Upgrading instances” topic in the *Upgrading to DB2 Version 9.7* using the `db2iupgrade` command.
4. Upgrade any existing transaction manager and DB2 Connect federated databases by referring to the “Upgrading databases” topic in the *Upgrading to DB2 Version 9.7*. You can also upgrade your databases by restoring a DB2 Connect backup from one of the two previous supported versions.

After upgrading the DB2 Connect server, perform the recommended post-upgrade tasks such as resetting the diagnostic error level, adjusting log space size, and rebinding packages, and verifying that your upgrade was successful.

Post-upgrade tasks for DB2 Connect servers

After upgrading your DB2 Connect servers, you should perform several post-upgrade tasks to ensure that your DB2 Connect servers perform as expected and run at their optimum level.

Perform the following post-upgrade tasks for DB2 servers that also apply to DB2 Connect servers:

1. If you set the *diaglevel* database manager configuration parameter to 4 as recommended in the pre-upgrade tasks for DB2 Connect servers, reset this parameter to the value set before the upgrade.
2. Refer to the “Manage changes in DB2 server behavior” topic in the *Upgrading to DB2 Version 9.7*. There are new registry variables, new configuration parameters, and new default values for registry variables and configuration parameters introduced in latest version or release of DB2 products that can impact the behavior of DB2 server. There are also changes in physical design characteristics of databases and changes to security that also have an impact.
3. If you obtained customized code page conversion tables from the DB2 support service for previous versions or releases, copy all of the files for those tables from the DB2OLD/conv to DB2DIR/conv, where DB2OLD is the location of your previous supported version of DB2 Connect copy and DB2DIR is the location of your new DB2 Connect copy. You do not need to copy standard code page conversion tables.

If you upgraded your existing, supported DB2 Connect copy on Windows operating systems, you can restore the customized code page conversion tables that you backed up as part of the pre-upgrade tasks for DB2 Connect servers to the DB2PATH\conv directory, where DB2PATH is the location of your new DB2 Connect copy.

4. If you are connecting to a DB2 for z/OS server or a DB2 for IBM i server where euro support is required, set the **DB2CONNECT_ENABLE_EURO_CODEPAGE** registry variable to YES on all DB2 Connect clients and servers so that the current application code page is mapped to the equivalent coded character set ID (CCSID) that explicitly indicates support for the euro sign.
5. Optional: If you upgraded any databases in your DB2 Connect server and changed the log space setting as recommended in the pre-upgrade tasks for DB2 Connect servers, refer to the “Adjusting the log space size in migrated databases” topic in the *Upgrading to DB2 Version 9.7*. Ensure that the amount of log space that you allocate is adequate for your DB2 Connect server.
6. Optional: Refer to the “Backing up databases before upgrading” topic in the *Upgrading to DB2 Version 9.7* after the upgrade is complete.
7. Optional: If you have DB2 Connect federated databases, review the “Configuring federated systems after migration” topic in *IBM WebSphere Information Integration: Migrating to Federation Version 9* to determine if you need to perform any tasks after you upgrade your federated databases.
8. Verify that your DB2 Connect server upgrade was successful. Test connections to all your cataloged databases. The following example shows how to test a connection from the Command Line Processor (CLP):

```
db2 CONNECT TO DATABASE sample user mickey using mouse
```

You need to specify a user and password when connecting to a remote database. Ensure all connections are successful.

Also, test your applications and tools to ensure that the DB2 Connect server is working as expected.

At this point, you should resume all of your maintenance activities. You should also remove any previously supported versions or releases of DB2 Connect copies that you no longer need.

Part 4. Preinstallation tasks

Chapter 4. Java software support for DB2 products

You require the appropriate level of IBM Software Development Kit (SDK) for Java, listed later in this section, to use Java-based tools and to create and run Java applications, including stored procedures and user-defined functions.

If the IBM SDK for Java is required by a component being installed and the SDK for Java is not already installed in that path, the SDK for Java will be installed if you use either the DB2 Setup wizard or a response file to install the product.

The SDK for Java is not installed with IBM Data Server Runtime Client or IBM Data Server Driver Package.

The following table lists the installed SDK for Java levels for DB2 products according to operating system platform:

Operating System Platform	SDK for Java level
AIX	SDK 6
HP-UX for Itanium-based systems	HP SDK for J2SE HP-UX 11i platform, adapted by IBM for IBM Software, Version 6 Service Release 3
Linux on x86	SDK 6 Service Release 3
Linux on AMD64/EM64T	SDK 6 Service Release 3
Linux on zSeries®	SDK 6 Service Release 3
Linux on POWER®	SDK 6 Service Release 3
Solaris Operating System	SDK 6 Service Release 3
Windows x86	SDK 6 Service Release 3
Windows x64	SDK 6 Service Release 3

Note:

1. The SDK for Java software can be downloaded from the developerWorks® Web page at: <http://www.ibm.com/developerworks/java/jdk/index.html> . For a list of the supported levels of the SDK for Java, see the table later in this section entitled DB2 Database for Linux, UNIX, and Windows support for SDKs for Java.

Note: For Windows operating system platforms, use the IBM Development Package for Eclipse downloads.

2. DB2 GUI tools only run on Linux on x86, Linux on AMD64/EM64T, Windows x86, and Windows x64.
3. On Windows x86 and Linux on x86:
 - the 32-bit SDK is installed
 - 32-bit applications and Java external routines are supported
4. On all supported platforms (except Windows x86, and Linux on x86):
 - 32-bit applications are supported
 - 32-bit Java external routines are not supported
 - 64-bit applications and Java external routines are supported

Supported Java application development software

The following table lists the supported levels of the SDK for Java. The listed levels and forward-compatible later versions of the same levels are supported.

Because there are frequent SDK for Java fixes and updates, not all levels and versions have been tested. If your database application has problems that are related to the SDK for Java, try the next available version of your SDK for Java at the given level.

Non-IBM versions of the SDK for Java are supported only for building and running stand-alone Java applications. For building and running new Java stored procedures and user-defined functions, only the IBM SDK for Java that is included with the DB2 Database for Linux, UNIX, and Windows product is supported. For running Java stored procedures and user-defined functions that were built by prior DB2 releases, refer to Table 1, column “Java Stored Procedures and User Defined Functions” for details.

Table 2. DB2 Database for Linux, UNIX, and Windows supported levels of SDKs for Java

	Java applications using JDBC driver db2java.zip or db2jcc.jar	Java applications using JDBC driver db2jcc4.jar	Java Stored Procedures and User Defined Functions	DB2 Graphical Tools
AIX	1.4.2 to 6	6	1.4.26 on page 33 to 6 ⁵	N/A
HP-UX for Itanium-based systems	1.4.2 to 6 ¹	6 ¹	1.4.26 on page 33 to 6	N/A
Linux on POWER	1.4.2 to 6 ^{3,4}	6 ^{3,4}	1.4.26 on page 33 to 6	N/A
Linux on x86	1.4.2 to 6 ^{2,3,4}	6 ^{2,3,4}	1.4.26 on page 33 to 6	5 to 6
Linux on AMD64 and Intel® EM64T processors	1.4.2 to 6 ^{2,3,4}	6 ^{2,3,4}	1.4.26 on page 33 to 6	N/A
Linux on zSeries	1.4.2 to 6 ^{3,4}	6 ^{3,4}	1.4.26 on page 33 to 6	N/A
Solaris operating system	1.4.2 to 6 ²	6 ²	1.4.26 on page 33 to 6	N/A
Windows on x86	1.4.2 to 6 ²	6 ²	1.4.6 on page 332 to 6	5 to 6
Windows on x64, for AMD64 and Intel EM64T processors	1.4.2 to 6 ²	6 ²	1.4.26 on page 33 to 6	5 to 6

Note:

1. The same levels of the SDK for Java that are available from Hewlett-Packard are supported for building and running stand-alone client applications that run under the IBM Data Server Driver for JDBC and SQLJ.
2. The same levels of the SDK for Java that are available from Sun Microsystems are supported for building and running stand-alone client applications that run under the IBM Data Server Driver for JDBC and SQLJ.
3. A minimum level of SDK for Java 1.4.2 SR6 is required for SUSE Linux Enterprise Server (SLES) 10. A minimum level of SDK for Java 1.4.2 SR7 is required for Red Hat Enterprise Linux (RHEL) 5.
4. SDK for Java 6 support on Linux requires SDK for Java 6 SR3 or later.
5. If SDK for Java 6 SR2 or later is used, set `DB2LIBPATH=java_home/jre/lib/ppc64`.

6. Support for Java stored procedures and user-defined functions built by IBM SDK for Java 1.4.2 has been deprecated in Version 9.7 and might be removed in a future release. IBM SDK for Java 1.4.2 has an End of Service date of September 2011. It is recommended to remove SDK for Java 1.4.2 dependency well before this date. Removing this dependency can be done by rebuilding Java stored procedures and user-defined functions with the SDK for Java included in DB2 Version 9.1, DB2 Version 9.5, or DB2 Version 9.7.

The following table lists the versions of the IBM Data Server Driver for JDBC and SQLJ that are available with DB2 database products.

Table 3. Versions of IBM Data Server Driver for JDBC and SQLJ and DB2 Database for Linux, UNIX, and Windows fix pack levels

DB2 version and fix pack level	IBM Data Server Driver for JDBC and SQLJ version¹
DB2 Version 9.1	3.1.xx
DB2 Version 9.1 Fix Pack 1	3.2.xx
DB2 Version 9.1 Fix Pack 2	3.3.xx
DB2 Version 9.1 Fix Pack 3	3.4.xx
DB2 Version 9.1 Fix Pack 4	3.6.xx
DB2 Version 9.1 Fix Pack 5	3.7.xx
DB2 Version 9.5	3.50.xx, 4.0.xx
DB2 Version 9.5 Fix Pack 1	3.51.xx, 4.1.xx
DB2 Version 9.5 Fix Pack 2	3.52.xx, 4.2.xx
DB2 Version 9.5 Fix Pack 3	3.53.xx, 4.3.xx
DB2 Version 9.7	3.57.xx, 4.7.xx
DB2 Version 9.7 Fix Pack 1	3.58.xx, 4.8.xx

Note: All driver versions are of the form *n.m.xx*. *n.m* stays the same within a GA level or a fix pack level. *xx* changes when a new version of the IBM Data Server Driver for JDBC and SQLJ is introduced through an APAR fix.

Chapter 5. Kernel parameters (Linux and UNIX)

Kernel configuration parameters may need to be updated to allow DB2 Connect (and other DB2 products) to perform properly. Each of the supported operating systems is discussed with the goal of showing how to modify the respective kernel configuration parameters.

Modifying kernel parameters (HP-UX)

For your DB2 product to perform properly on HP-UX, you might need to update your system's kernel configuration parameters. If you update your kernel configuration parameter values, you must restart your computer.

You must have root authority to modify kernel parameters.

To modify kernel parameters:

1. Enter the **sam** command to start the System Administration Manager (SAM) program.
2. Double-click the **Kernel Configuration** icon.
3. Double-click the **Configurable Parameters** icon.
4. Double-click the parameter that you want to change and type the new value in the **Formula/Value** field.
5. Click **OK**.
6. Repeat these steps for all of the kernel configuration parameters that you want to change.
7. When you are finished setting all of the kernel configuration parameters, select **Action --> Process New Kernel** from the action menu bar.

The HP-UX operating system automatically restarts after you change the values for the kernel configuration parameters.

Recommended kernel configuration parameters (HP-UX)

For HP-UX systems running a DB2 64-bit database system, run the `db2osconf` command to suggest appropriate kernel configuration parameter values for your system. The `db2osconf` utility can only be run from `$DB2DIR/bin`, where `$DB2DIR` is the directory where you installed your DB2 product.

Modifying kernel parameters (Linux)

Before installing a DB2 database system, update your Linux kernel parameters. The default values for particular kernel parameters on Linux are not sufficient when running a DB2 database system.

You must have root authority to modify kernel parameters.

To update kernel parameters on Red Hat and SUSE Linux:

1. Run the `ipcs -l` command

- Analyze the output to determine if there are any necessary changes required for your system. Comments have been added following the // to show what the parameter names are.

```
# ipcs -l

----- Shared Memory Limits -----
max number of segments = 4096           // SHMMNI
max seg size (kbytes) = 32768          // SHMMAX
max total shared memory (kbytes) = 8388608 // SHMALL
min seg size (bytes) = 1

----- Semaphore Limits -----
max number of arrays = 1024            // SEMMNI
max semaphores per array = 250        // SEMMSL
max semaphores system wide = 256000   // SEMMNS
max ops per semop call = 32           // SEMOPM
semaphore max value = 32767

----- Messages: Limits -----
max queues system wide = 1024         // MSGMNI
max size of message (bytes) = 65536   // MSGMAX
default max size of queue (bytes) = 65536 // MSGMNB
```

- Beginning with the first section on Shared Memory Limits, SHMMAX and SHMALL are the parameters that need to be looked at. SHMMAX is the maximum size of a shared memory segment on a Linux system whereas SHMALL is the maximum allocation of shared memory pages on a system.
 - It is recommended to set the SHMMAX value to be equal to the amount of physical memory on your system. However, the minimum required on x86 systems is 268435456 (256 MB) and for 64-bit systems, it is 1073741824 (1 GB).
 - SHMALL is set to 8 GB by default (8388608 KB = 8 GB). If you have more physical memory than this, and it is to be used for DB2, then this parameter increases to approximately 90% of your computer's physical memory. For instance, if you have a computer system with 16 GB of memory to be used primarily for DB2, then SHMALL should be set to 3774873 (90% of 16 GB is 14.4 GB; 14.4 GB is then divided by 4 KB, which is the base page size). The ipcs output has converted SHMALL into kilobytes. The kernel requires this value as a number of pages. If you are upgrading to DB2 Version 9.7 and you are not using the default SHMALL setting, you must increase the SHMALL setting by an additional 4 GB. This increase in memory is required by the fast communication manager (FCM) for additional buffers or channels.
- The next section covers the amount of semaphores available to the operating system. The kernel parameter sem consists of 4 tokens, SEMMSL, SEMMNS, SEMOPM and SEMMNI. SEMMNS is the result of SEMMSL multiplied by SEMMNI. The database manager requires that the number of arrays (SEMMNI) be increased as necessary. Typically, SEMMNI should be twice the maximum number of agents expected on the system multiplied by the number of logical partitions on the database server computer plus the number of local application connections on the database server computer.
- The third section covers messages on the system.
 - MSGMNI affects the number of agents that can be started, MSGMAX affects the size of the message that can be sent in a queue, and MSGMNB affects the size of the queue.
 - MSGMAX should be change to 64 KB (that is, 65535 bytes), and MSGMNB should be increased to 65535.

3. To modify these kernel parameters, edit the `/etc/sysctl.conf` file. If this file does not exist, create it. The following lines are examples of what should be placed into the file:

```
kernel.sem=250 256000 32 1024
#Example shmmax for a 64-bit system
kernel.shmmax=1073741824
#Example shmall for 90 percent of 16 GB memory
kernel.shmall=3774873
kernel.msgmax=65535
kernel.msgmnb=65535
kernel.msgmni=2048
```
4. Run `sysctl` with `-p` parameter to load in `sysctl` settings from the default file `/etc/sysctl.conf`:

```
sysctl -p
```
5. To make the changes effective after every reboot:
 - (SUSE Linux) Make `boot.sysctl` active
 - (Red Hat) The `rc.sysinit` initialization script will read the `/etc/sysctl.conf` file automatically

Modifying kernel parameters (Solaris Operating System)

For the DB2 database system to operate properly, it is recommended that you update your system's kernel configuration parameters. You can use the `db2osconf` utility to suggest recommended kernel parameters. If you want to take advantage of project resource controls (`/etc/project`), consult your Solaris documentation.

You must have root authority to modify kernel parameters.

To use the `db2osconf` command, you must first install the DB2 database system. The `db2osconf` utility can only be run from `$DB2DIR/bin`, where `$DB2DIR` is the directory where you installed your DB2 product.

You must restart your system after modifying kernel parameters.

To set a kernel parameter, add a line at the end of the `/etc/system` file as follows:

```
set parameter_name = value
```

For example, to set the value of the `msgsys:msginfo_msgmax` parameter, add the following line to the end of the `/etc/system` file:

```
set msgsys:msginfo_msgmax = 65535
```

After updating the `/etc/system` file, restart the system.

Part 5. Installation and configuration tasks

Chapter 6. DB2 Connect server products: installation and configuration overview

Setting up a DB2 Connect server product, such as DB2 Connect Enterprise Edition, is a multi-step process. DB2 Connect server products are often installed with hundreds or thousands of clients connecting to IBM mainframe database servers. For this reason, it is recommended to use a test installation, outlined below. After the test configuration has proven stable, you can use it as the template for an unattended installation of DB2 Connect and your clients across your organization.

The typical steps to installing and configuring a DB2 Connect server product are as follows:

1. Determine how you want to use DB2 Connect in your network.
2. Verify that you have the correct hardware and software prerequisites on both your workstation and the host database server.
3. Verify that your IBM mainframe database server is configured to accept connections from DB2 Connect servers.
4. Install your DB2 Connect software. You will use this workstation to configure and verify your IBM mainframe connections. Use the related links to find the details specific to the installation of a DB2 Connect server product on your operating system.
5. After installation, establish the connection between DB2 Connect and your IBM mainframe database system. DB2 Connect can locate and configure all TCP/IP connections for you. You can use the Configuration Assistant (CA) or the DB2 command line processor (CLP) to configure IBM mainframe databases.
6. Bind the programs and utilities provided with DB2 Connect to your IBM mainframe database.
7. Test the connection.
8. (Optional) Enable the Multisite Update feature.
9. If you are planning to use WebSphere, transaction monitors, or your own application server software, install these products or applications. For information on installing WebSphere consult the documentation provided with these products as part of the DB2 Connect server product package. For other products consult the installation documentation provided with the product.
10. Install and configure the IBM data server client. Use this workstation to test connectivity from the IBM data server client to IBM mainframe database servers, as well as to test applications that use this connectivity.
11. Use the Configuration Assistant to connect the client to the IBM mainframe system through DB2 Connect.
12. Install a IBM data server client on all end-user workstations that will use applications that connect to IBM mainframe database servers.
13. You are now ready to use DB2 Connect with all your applications. Workstations that will be used for application development should have the IBM data server client installed.
14. If you want to use your workstation to administer DB2 for z/OS or DB2 Database for Linux, UNIX, and Windows, install the IBM data server client.

Chapter 7. Disk and memory requirements

Disk requirements

The disk space required for your product depends on the type of installation you choose and the type of file system you have. The DB2 Setup wizard provides dynamic size estimates based on the components selected during a typical, compact, or custom installation.

Remember to include disk space for required databases, software and communication products.

On Linux and UNIX operating systems, 2 GB of free space in the /tmp directory is recommended.

Memory requirements

At a minimum, a DB2 database system requires 256 MB of RAM. For a system running just a DB2 product and the DB2 GUI tools, a minimum of 512 MB of RAM is required. However, 1 GB of RAM is recommended for improved performance. These requirements do not include any additional memory requirements for other software that is running on your system.

When determining memory requirements, be aware of the following:

- DB2 products that run on HP-UX Version 11i for Itanium-based systems require 512 MB of RAM at a minimum.
- For IBM data server client support, these memory requirements are for a base of five concurrent client connections. You will need an additional 16 MB of RAM per five client connections.
- Memory requirements are affected by the size and complexity of your database system, and the extent of database activity and the number of clients accessing your system.

For DB2 server products, the self-tuning memory feature simplifies the task of memory configuration by automatically setting values for several memory configuration parameters. When enabled, the memory tuner dynamically distributes available memory resources among several memory consumers including sort, the package cache, the lock list and buffer pools.

- On Linux and UNIX operating systems, SWAP space at least twice as large as RAM is recommended.

Chapter 8. Installing a DB2 Connect server product (AIX)

To define your installation preferences and to install a DB2 Connect product on AIX, use the DB2 Setup wizard.

The DB2 Installer program is a Java-based installation tool that automates the installation and configuration of any DB2 product. If you prefer not to use this utility, you have two alternatives. You can install a DB2 Connect product:

- Using the response file method
- Manually using the `db2_install` command. You *cannot* manually install a DB2 product using the operating system's native installation utility SMIT. Any existing scripts containing this native installation utility that you use to interface and query with DB2 installations will need to change.

Prerequisites

Before you begin your installation:

- You can install DB2 Connect using either root or non-root authority. For more information on non-root installation, see the related links.
- Ensure that your system meets:
 - Disk and memory requirements
 - Hardware, distribution and software requirements
- The DB2 product DVD must be mounted on your system.
- The DB2 Connect product image must be available. If you are installing a non-English version of a DB2 Connect product, you must also have the appropriate National Language Packages.
- Ensure that asynchronous I/O has been enabled; it must be enabled before your DB2 Connect server product can be successfully installed.
- To locate DB2 products already installed on your system, see the “Listing DB2 products installed on your system (Linux and UNIX)” topic in *Installing DB2 Servers*.
- The DB2 Setup wizard is a graphical installer. You must have X windows software capable of rendering a graphical user interface for the DB2 Setup wizard to run on your machine. Ensure that the X windows server is running. Ensure that you have properly exported your display. For example, export `DISPLAY=9.26.163.144:0`.
- If security software such as Lightweight Directory Access Protocol (LDAP) is used in your environment, you must manually create required DB2 users before you start the DB2 Setup wizard. Refer to the “Centralized user-management considerations” topic before you begin.

Note: Network Information Services (NIS) and Network Information Services Plus (NIS+) features are deprecated starting with DB2 Version 9.1 Fix Pack 2. Support for these features might be removed in a future release. Lightweight Directory Access Protocol (LDAP) is the recommended solution for centralized user-management services.

To install a DB2 Connect server product, such as DB2 Connect Enterprise Edition, on AIX using the DB2 Setup wizard:

1. Change to the directory where the DVD is mounted:

```
cd /db2dvd
```

where */db2dvd* represents mount point of the DVD.

2. If you downloaded the DB2 Connect product image, you must decompress and untar the product file.

- a. Decompress the product file:

```
gzip -d product.tar.gz
```

where *product* is the name of the database product that you downloaded.

- b. Untar the product file:

```
tar xvf product.tar
```

- c. Change directory:

```
cd ./product/disk1
```

Note: If you downloaded a National Language Package, untar it into the same directory. This will create the subdirectories (for example *./nlpack/disk2*) in the same directory, and allows the installer to automatically find the installation images without prompting

3. Enter the *./db2setup* command from the directory where the product image resides to start the DB2 Setup wizard. After a few moments, the IBM DB2 Setup Launchpad opens. For multiple CD installations, issue the *db2setup* command outside the mounted CD location with either a relative or absolute path name to ensure the DB2 Connect product CD can be unmounted as required. From this window, you can view the installation prerequisites and the release notes or you can proceed directly to the installation.
4. Once you have initiated the installation, proceed through the DB2 Setup wizard installation panels and make your selections. Installation help is available to guide you through the DB2 Setup wizard. Click **Help** to invoke the online help. You can click **Cancel** at any time to exit the installation. DB2 files will only be copied to your system once you have clicked **Finish** on the last DB2 Setup wizard installation panel. Once completed, the DB2 Connect server product is installed using the */opt/IBM/db2/V9.5* default installation path.

If you are installing on a system where this directory is already being used, the DB2 Connect product installation path will have *_xx* added to it, where *xx* are digits, starting at 01 and increasing depending on how many DB2 copies you have installed.

You can also specify your own DB2 database product installation path.

National Language Packs can also be installed by running the *./db2setup* command from the directory where the National Language Pack resides, after a DB2 Connect product has been installed.

The installation logs, *db2setup.log* and *db2setup.err* will be located, by default, in the */tmp* directory. You can specify the location of the log files.

If you want your DB2 product to have access to DB2 documentation either on your local computer or on another computer on your network, then you must install the DB2 Information Center. The DB2 Information Center contains documentation for the DB2 database and DB2 related products. See the “Installing the DB2 Information Center using the DB2 Setup wizard (UNIX)” topic in *Installing DB2 Servers* .

Installation requirements for DB2 Connect server products (AIX)

Before you install DB2 Connect server products on AIX operating systems, ensure that the system you choose meets the necessary operating system, hardware, software, and communications requirements.

To install a DB2 Connect server product, such as DB2 Connect Enterprise Edition, the following requirements must be met:

Installation requirements

Table 4. AIX installation requirements

Operating System	Hardware
AIX Version 5.3 <ul style="list-style-type: none">64-bit AIX kernel is requiredAIX 5.3 Technology Level (TL) 9 and Service Pack (SP) 2 plus APAR IZ03063Minimum C++ runtime level requires the xIC.rte 9.0.0.8 and xIC.aix50.rte 9.0.0.8 (or later) filesets. These filesets are included in the June 2008 IBM C++ Runtime Environment Components for AIX package.	64-bit Common Hardware Reference Platform (CHRP) architecture, excluding POWER3™ processor-based systems. ¹ All processors that are capable of running the supported AIX operating systems.
AIX Version 6.1 ² <ul style="list-style-type: none">64-bit AIX kernel is requiredAIX 6.1 TL 2Minimum C++ runtime level requires the xIC.rte 9.0.0.8 and xIC.aix61.rte 9.0.0.8 (or later) filesets. These filesets are included in the June 2008 IBM C++ Runtime Environment Components for AIX package.	

- ¹To verify that it is a CHRP architecture system, issue the command `lscfg` and look for the following output: `Model Architecture: chrp`. For POWER3 processor-based systems, first upgrade to POWER4™ processor-based systems before installing DB2 Version 9.7. POWER3 processor-based systems are not supported in DB2 Version 9.7.
- ²In AIX 6.1 there are two types of Workload Partitions (WPARs): system WPARs and application WPARs. DB2 installation is supported only on a system WPAR. AIX 6.1 also supports the ability to encrypt a JFS2 file system or set of files.

Software requirements

- Use the `bosboot` command to switch to the 64-bit kernel.

To switch to a 64-bit kernel, you require root authority and should enter the following commands:

```
ln -sf /usr/lib/boot/unix_64 /unix
ln -sf /usr/lib/boot/unix_64 /usr/lib/boot/unix
bosboot -a
shutdown -Fr
```

- For application development and runtime considerations, see the topics in Supported programming languages and compilers for database application development.

- You can download the latest IBM C++ Runtime Environment Components for AIX from the IBM AIX XL C and C++ support Web site.
- One of the following browsers is required to view online help and to run First Steps (db2fs):
 - Firefox 1.0 and later
 - Mozilla-based browsers 1.7 and later
 - Safari 3.0 and later
- For details regarding known AIX issues, see www.ibm.com/support/docview.wss?&uid=swg21165448

Communication requirements

When using a communication protocol, you have the following requirements:

- For TCP/IP connectivity, no additional software is required.
- For LDAP (Lightweight Directory Access Protocol) support, you require an IBM SecureWay™ Directory Client V3.2.1 or later.

DB2 product installation on NFS (Network File System)

The installation of DB2 products on NFS (Network File System) is not recommended. Running DB2 products on NFS (for example, NFS mounting /opt/IBM/db2/V9.5 and then running off code that was physically installed on a remote system) requires several manual setup steps. There are also a number of potential issues with setting up NFS for a DB2 server. These include possible problems that involve:

- Performance (impacted by network performance)
- Availability (you are allowing a single point of failure)
- Licensing (there is no checking done across machines)
- Diagnosing NFS errors can be difficult

As mentioned, the setup for NFS will require several manual actions including:

- Ensuring that the mount point preserve the install path
- Permission must be controlled (for example, write permission should not be given to the mounting machine)
- DB2 registries have to be set up manually and maintained across all mounting machines
- The db2ls command, which lists installed DB2 products and features, must be set up and maintained properly if you need to detect DB2 products and features
- More care is required when updating your DB2 product environment
- More steps are required when cleaning up on the exporting machine and the mounting machine

For detailed instructions, see the "Setting up DB2 for UNIX and Linux on NFS mounted file systems" white paper in <http://www.ibm.com/developerworks/db2/library/long/dm-0609lee>.

Mounting CDs or DVDs (AIX)

Depending on your system configuration, you might need to log on as root to mount discs.

To mount the CD or DVD on AIX using the System Management Interface Tool (SMIT), perform the following steps:

1. Insert the disc in the drive.
2. Create a disc mount point by entering the `mkdir -p /disc` command, where `disc` represents the CD or DVD mount point directory.
3. Allocate a disc file system using SMIT by entering the `smit storage` command.
4. After SMIT starts, select **File Systems** → **Add / Change / Show / Delete File Systems** → **CDROM File Systems** → **Add CDROM File System**.
5. In the Add a File System window:
 - Enter a device name for your CD or DVD file system in the **DEVICE Name** field. Device names for CD or DVD file systems must be unique. If there is a duplicate device name, you may need to delete a previously-defined CD or DVD file system or use another name for your directory. In our example, we will use `/dev/cd0` as the device name.
 - Enter the disc mount point directory in the **MOUNT POINT** window. In our example, the mount point directory is `/disc`.
 - In the **Mount AUTOMATICALLY at system restart** field, select **yes** to enable automatic mounting of the file system.
 - Click **OK** to close the window, then click **Cancel** three times to exit SMIT.
6. Next, mount the CD or DVD file system by entering the `smit mountfs` command.
7. In the Mount a File System window:
 - Enter the device name for this CD or DVD file system in the **FILE SYSTEM name** field. In our example, the device name is `/dev/cd0`.
 - Enter the disc mount point in the **Directory over which to mount** field. In our example, the mount point is `/disc`.
 - Enter `cdarfs` in the **Type of Filesystem** field. To view the other kinds of file systems you can mount, click **List**.
 - In the **Mount as READ-ONLY system** field, select **yes**.
 - Accept the remaining default values and click **OK** to close the window.

Your CD or DVD file system is now mounted. To view the contents of the CD or DVD, place the disk in the drive and enter the `cd /disc` command where `disc` is the disc mount point directory.

Chapter 9. Installing a DB2 Connect server product (HP-UX)

To define your installation preferences and to install a DB2 Connect product on HP-UX, use the DB2 Setup wizard.

The DB2 Installer program is a Java-based installation tool that automates the installation and configuration of any DB2 product. If you prefer not to use this utility, you have two alternatives. You can install a DB2 Connect product:

- Using the response file method
- Manually using the `db2_install` command. You *cannot* manually install a DB2 product using the operating system's native installation utility `swinstall`. Any existing scripts containing this native installation utility that you use to interface and query with DB2 installations will need to change.

Prerequisites

Before you begin your installation:

- You can install DB2 Connect using either root or non-root authority. For more information on non-root installation, see the related links.
- Ensure that your system meets:
 - Disk and memory requirements
 - Hardware, distribution and software requirements
- The DB2 product DVD must be mounted on your system.
- The DB2 Connect product image must be available. If you are installing a non-English version of a DB2 Connect product, you must also have the appropriate National Language Packages.
- To locate DB2 products already installed on your system, see the “Listing DB2 products installed on your system (Linux and UNIX)” topic in *Installing DB2 Servers*.
- The DB2 Setup wizard is a graphical installer. You must have X windows software capable of rendering a graphical user interface for the DB2 Setup wizard to run on your machine. Ensure that the X windows server is running. Ensure that you have properly exported your display. For example, export `DISPLAY=9.26.163.144:0`.
- If security software such as Lightweight Directory Access Protocol (LDAP) is used in your environment, you must manually create required DB2 users before you start the DB2 Setup wizard. Refer to the “Centralized user-management considerations” topic before you begin.

Note: Network Information Services (NIS) and Network Information Services Plus (NIS+) features are deprecated starting with DB2 Version 9.1 Fix Pack 2. Support for these features might be removed in a future release. Lightweight Directory Access Protocol (LDAP) is the recommended solution for centralized user-management services.

To install a DB2 Connect server product, such as DB2 Connect Enterprise Edition, on HP-UX using the DB2 Setup wizard:

1. Change to the directory where the DVD is mounted:

```
cd /db2dvd
```

where */db2dvd* represents mount point of the DVD.

2. If you downloaded the DB2 Connect product image, you must decompress and untar the product file.

- a. Decompress the product file:

```
gzip -d product.tar.gz
```

where *product* is the name of the database product that you downloaded.

- b. Untar the product file:

```
tar xvf product.tar
```

- c. Change directory:

```
cd ./product/disk1
```

Note: If you downloaded a National Language Package, untar it into the same directory. This will create the subdirectories (for example *./nlpack/disk2*) in the same directory, and allows the installer to automatically find the installation images without prompting

3. Enter the *./db2setup* command from the directory where the product image resides to start the DB2 Setup wizard. After a few moments, the IBM DB2 Setup Launchpad opens. For multiple CD installations, issue the *db2setup* command outside the mounted CD location with either a relative or absolute path name to ensure the DB2 Connect product CD can be unmounted as required. From this window, you can view the installation prerequisites and the release notes or you can proceed directly to the installation.
4. Once you have initiated the installation, proceed through the DB2 Setup wizard installation panels and make your selections. Installation help is available to guide you through the DB2 Setup wizard. Click **Help** to invoke the online help. You can click **Cancel** at any time to exit the installation. DB2 files will only be copied to your system once you have clicked **Finish** on the last DB2 Setup wizard installation panel. Once completed, the DB2 Connect server product is installed using the */opt/IBM/db2/v9.5* default installation path.

If you are installing on a system where this directory is already being used, the DB2 Connect product installation path will have *_xx* added to it, where *xx* are digits, starting at 01 and increasing depending on how many DB2 copies you have installed.

You can also specify your own DB2 database product installation path.

National Language Packs can also be installed by running the *./db2setup* command from the directory where the National Language Pack resides, after a DB2 Connect product has been installed.

The installation logs, *db2setup.log* and *db2setup.err* will be located, by default, in the */tmp* directory. You can specify the location of the log files.

If you want your DB2 product to have access to DB2 documentation either on your local computer or on another computer on your network, then you must install the DB2 Information Center. The DB2 Information Center contains documentation for the DB2 database and DB2 related products. See the “Installing the DB2 Information Center using the DB2 Setup wizard (UNIX)” topic in *Installing DB2 Servers* .

Installation requirements for DB2 Connect server products (HP-UX)

Before you install DB2 Connect server products on HP-UX operating systems, ensure that the system you choose meets the necessary operating system, hardware, software, and communications requirements.

To install a DB2 Connect server product, such as DB2 Connect Enterprise Edition, on HP-UX, the following requirements must be met:

Installation requirements

Table 5. HP-UX installation requirements

Operating System	Hardware
HP-UX 11i v2 (11.23.0505) with: <ul style="list-style-type: none">• May 2005 Base Quality (QPKBASE) bundle• May 2005 Applications Quality (QPKAPPS) bundle	Itanium® based HP Integrity Series Systems
HP-UX 11i v3 (11.31)	

Software requirements

- A browser is required to view online help.
- For details regarding known HP-UX issues, see www.ibm.com/support/docview.wss?&uid=swg21257602

Communication requirements

You can use TCP/IP

- For TCP/IP connectivity, no additional software is required.

Note: Starting in DB2 V9.7 Fix Pack 1 and later, DB2 products installed on the HP-UX operating system support long host names. The length has been extended to 255 bytes, in any combination of characters or digits. The minimum operating system requirement is HP-UX 11i v2 (and above).

To enable long host name support, complete the following tasks:

1. Turn on the kernel tunable parameter `expanded_node_host_name`.
`Kctune expanded_node_host_name=1`
2. Compile applications requiring long host name support with the `-D_HPUX_API_LEVEL=20040821` option.

Mounting CDs or DVDs (HP-UX)

This topic explains how to mount your DB2 product CD or DVD for HP-UX.

Depending on your system configuration, you might need to log on as root to mount discs.

To mount your DB2 for HP-UX product CD or DVD:

1. Insert the CD or DVD in the drive.
2. If necessary, define a new directory as the mount point for the CD or DVD drive. Define `/cdrom` as the mount point using the `mkdir /cdrom` command.

3. If necessary, identify the drive device file using the `ioscan -fnC disk` command. This command lists all recognized CD or DVD drives and their associated device files. The file name will be something similar to `/dev/dsk/c1t2d0`.
4. Mount the CD or DVD drive to the mount-point directory:

```
mount -F cdfs -o rr /dev/dsk/c1t2d0 /cdrom
```
5. Obtain a file listing to verify the mount using the `ls /cdrom` command.
6. Log out.

Your CD or DVD file system is now mounted. View the contents of the CD or DVD by placing it in the drive and enter the `cd /cdrom` command where `cdrom` is the mount point directory.

Chapter 10. Installing a DB2 Connect server product (Linux)

To define your installation preferences and to install a DB2 Connect product on Linux, use the DB2 Setup wizard.

The DB2 Setup wizard is a Java-based installation tool that automates the installation and configuration of any DB2 products. If you prefer not to use this utility, you have two alternatives. You can install a DB2 Connect product:

- Using the response file method
- Manually using the `db2_install` command. You *cannot* manually install a DB2 product using the operating system's native installation utility `rpm`. Any existing scripts containing this native installation utility that you use to interface and query with DB2 installations will need to change.

Prerequisites

Before you begin your installation:

- You can install DB2 Connect using either root or non-root authority. For more information on non-root installation, see the related links.
- Ensure that your system meets:
 - Disk and memory requirements
 - Hardware, distribution and software requirements
- The DB2 product DVD must be mounted on your system.
- The DB2 Connect product image must be available. If you are installing a non-English version of a DB2 Connect product, you must also have the appropriate National Language Packages.
- To locate DB2 products already installed on your system, see the "Listing DB2 products installed on your system (Linux and UNIX)" topic in *Installing DB2 Servers*.
- The DB2 Setup wizard is a graphical installer. You must have X windows software capable of rendering a graphical user interface for the DB2 Setup wizard to run on your machine. Ensure that the X windows server is running. Ensure that you have properly exported your display. For example, export `DISPLAY=9.26.163.144:0`.
- If security software such as Lightweight Directory Access Protocol (LDAP) is used in your environment, you must manually create required DB2 users before you start the DB2 Setup wizard. Refer to the "Centralized user-management considerations" topic before you begin.

Note: Network Information Services (NIS) and Network Information Services Plus (NIS+) features are deprecated starting with DB2 Version 9.1 Fix Pack 2. Support for these features might be removed in a future release. Lightweight Directory Access Protocol (LDAP) is the recommended solution for centralized user-management services.

To install a DB2 Connect server product, such as DB2 Connect Enterprise Edition, on Linux using the DB2 Setup wizard:

1. Change to the directory where the DVD is mounted:
`cd /db2dvd`

where */db2dvd* represents mount point of the DVD.

2. If you downloaded the DB2 Connect product image, you must decompress and untar the product file.

- a. Decompress the product file:

```
gzip -d product.tar.gz
```

where *product* is the name of the database product that you downloaded.

- b. Untar the product file:

```
tar xvf product.tar
```

- c. Change directory:

```
cd ./product/disk1
```

Note: If you downloaded a National Language Package, untar it into the same directory. This will create the subdirectories (for example *./nlpack/disk2*) in the same directory, and allows the installer to automatically find the installation images without prompting

3. Enter the *./db2setup* command from the directory where the product image resides to start the DB2 Setup wizard. After a few moments, the IBM DB2 Setup Launchpad opens. For multiple CD installations, issue the *db2setup* command outside the mounted CD location with either a relative or absolute path name to ensure the DB2 Connect product CD can be unmounted as required. From this window, you can view the installation prerequisites and the release notes or you can proceed directly to the installation.
4. Once you have initiated the installation, proceed through the DB2 Setup wizard installation panels and make your selections. Installation help is available to guide you through the DB2 Setup wizard. Click **Help** to invoke the online help. You can click **Cancel** at any time to exit the installation. DB2 files will only be copied to your system once you have clicked **Finish** on the last DB2 Setup wizard installation panel. Once completed, the DB2 Connect server product is installed using the */opt/IBM/db2/v9.5* default installation path.

If you are installing on a system where this directory is already being used, the DB2 Connect product installation path will have *_xx* added to it, where *xx* are digits, starting at 01 and increasing depending on how many DB2 copies you have installed.

You can also specify your own DB2 database product installation path.

National Language Packs can also be installed by running the *./db2setup* command from the directory where the National Language Pack resides, after a DB2 Connect product has been installed.

The installation logs, *db2setup.log* and *db2setup.err* will be located, by default, in the */tmp* directory. You can specify the location of the log files.

If you want your DB2 product to have access to DB2 documentation either on your local computer or on another computer on your network, then you must install the DB2 Information Center. The DB2 Information Center contains documentation for the DB2 database and DB2 related products. See the “Installing the DB2 Information Center using the DB2 Setup wizard (UNIX)” topic in *Installing DB2 Servers* .

Installation requirements for DB2 Connect server products (Linux)

Before you install DB2 Connect server products on Linux operating systems, ensure that the system you choose meets the necessary operating system, hardware, software, and communications requirements.

To install a DB2 Connect server product, such as DB2 Connect Enterprise Edition, the following requirements must be met:

Hardware requirements

Your processor can be:

- x86 (Intel Pentium[®], Intel Xeon[®], and AMD Athlon)
- x64 (Intel EM64T and AMD64)
- POWER (any iSeries[®], pSeries[®], System i, System p[®], and POWER Systems that support Linux)
- System z (formerly eServer[™] zSeries)

Distribution requirements

For the latest information on supported Linux distributions, point your browser to <http://www.ibm.com/db2/linux/validate>.

You might be required to update your kernel configuration parameters. The kernel configuration parameters are set in `/etc/sysctl.conf`. See the Modifying kernel parameters (Linux) section of the DB2 Information Center. Refer to your operating system manual for information on setting and activating these parameters using the `sysctl` command.

Software requirements

- An X Window System software capable of rendering a graphical user interface is required if you want to use the DB2 Setup wizard to install DB2 Connect or if you want to use any DB2 graphical tools.
- A browser is required to view online help.

Communication requirements

For TCP/IP connectivity, no additional software is required.

Preparing to install DB2 for Linux on zSeries

To install a DB2 product on an IBM zSeries that is running Linux, you must make the installation image accessible to the Linux operating system. You can use FTP to send the installation image to the operating system, or use an NFS mount to make the product DVD available to the operating system.

Prerequisites

You have already obtained your DB2 product installation image.

Using FTP to access the installation image

From the IBM zSeries computer running Linux:

1. Enter the following command:

```
ftp yourserver.com
```

where *yourserver.com* represents the FTP server where the DB2 product installation image resides.

2. Enter your user ID and password.

3. Enter the following commands:

```
bin
get product file
```

where *product file* represents the appropriate product package name.

Using the DB2 product DVD over NFS to access the installation image

To use the product DVD on a Linux operating system:

1. Mount the appropriate product DVD.
2. Export the directory where you mounted the DVD. For example, if you mounted the DVD under `/db2dvd`, then export the `/db2dvd` directory.
3. On the IBM zSeries computer running Linux, NFS mount this directory using the following command:

```
mount -t nfs -o ro nfsservername:/db2dvd /local_directory_name
```

where *nfsservername* represents the host name of the NFS server, *db2dvd* represents the name of the directory being exported on the NFS server, and *local_directory_name* represents the name of the local directory.

4. From the IBM zSeries computer running Linux, change to the directory where the DVD is mounted. You can do this by entering the `cd /local_directory_name` command, where *local_directory_name* represents the mount point of your product DVD.

Mounting the CD or DVD (Linux)

Depending on your system configuration, you can log on as root to mount discs.

To mount the CD or DVD on Linux operating systems:

1. Insert the CD or DVD in the drive and enter the following command:

```
mount -t iso9660 -o ro /dev/cdrom /cdrom
```

where */cdrom* represents the mount point of the CD or DVD.

2. Log out.

Your CD or DVD file system is now mounted. View the contents of the CD or DVD by placing the disc in the drive and enter the `cd /cdrom` command where `cdrom` is the mount point directory.

Chapter 11. Installing a DB2 Connect server product (Solaris Operating System)

To define your installation preferences and to install a DB2 Connect product on the Solaris operating system, use the DB2 Setup wizard.

The DB2 Setup wizard is a Java-based installation tool that automates the installation and configuration of any DB2 products. If you prefer not to use this utility, you have two alternatives. You can install a DB2 Connect product:

- Using the response file method
- Manually using the `db2_install` command. You *cannot* manually install a DB2 product using the operating system's native installation utility `pkgadd`. Any existing scripts containing this native installation utility that you use to interface and query with DB2 installations will need to change.

Prerequisites

Before you begin your installation:

- You can install DB2 Connect using either root or non-root authority. For more information on non-root installation, see the related links.
- Ensure that your system meets:
 - Disk and memory requirements
 - Hardware, distribution and software requirements
- The DB2 product DVD must be mounted on your system.
- The DB2 Connect product image must be available. If you are installing a non-English version of a DB2 Connect product, you must also have the appropriate National Language Packages.
- To locate DB2 products already installed on your system, see the “Listing DB2 products installed on your system (Linux and UNIX)” topic in *Installing DB2 Servers*.
- The DB2 Setup wizard is a graphical installer. You must have X windows software capable of rendering a graphical user interface for the DB2 Setup wizard to run on your machine. Ensure that the X windows server is running. Ensure that you have properly exported your display. For example, export `DISPLAY=9.26.163.144:0`.
- If security software such as Lightweight Directory Access Protocol (LDAP) is used in your environment, you must manually create required DB2 users before you start the DB2 Setup wizard. Refer to the “Centralized user-management considerations” topic before you begin.

Note: Network Information Services (NIS) and Network Information Services Plus (NIS+) features are deprecated starting with DB2 Version 9.1 Fix Pack 2. Support for these features might be removed in a future release. Lightweight Directory Access Protocol (LDAP) is the recommended solution for centralized user-management services.

To install a DB2 Connect server product, such as DB2 Connect Enterprise Edition, on the Solaris operating system using the DB2 Setup wizard:

1. Change to the directory where the DVD is mounted:

```
cd /db2dvd
```

where */db2dvd* represents mount point of the DVD.

2. If you downloaded the DB2 Connect product image, you must decompress and untar the product file.

- a. Decompress the product file:

```
gzip -d product.tar.gz
```

where *product* is the name of the database product that you downloaded.

- b. Untar the product file:

```
tar xvf product.tar
```

- c. Change directory:

```
cd ./product/disk1
```

Note: If you downloaded a National Language Package, untar it into the same directory. This will create the subdirectories (for example *./nlpack/disk2*) in the same directory, and allows the installer to automatically find the installation images without prompting

3. Enter the *./db2setup* command from the directory where the product image resides to start the DB2 Setup wizard. After a few moments, the IBM DB2 Setup Launchpad opens. For multiple CD installations, issue the *db2setup* command outside the mounted CD location with either a relative or absolute path name to ensure the DB2 Connect product CD can be unmounted as required. From this window, you can view the installation prerequisites and the release notes or you can proceed directly to the installation.
4. Once you have initiated the installation, proceed through the DB2 Setup wizard installation panels and make your selections. Installation help is available to guide you through the DB2 Setup wizard. Click **Help** to invoke the online help. You can click **Cancel** at any time to exit the installation. DB2 files will only be copied to your system once you have clicked **Finish** on the last DB2 Setup wizard installation panel. Once completed, the DB2 Connect server product is installed using the */opt/IBM/db2/v9.5* default installation path.

If you are installing on a system where this directory is already being used, the DB2 Connect product installation path will have *_xx* added to it, where *xx* are digits, starting at 01 and increasing depending on how many DB2 copies you have installed.

You can also specify your own DB2 database product installation path.

National Language Packs can also be installed by running the *./db2setup* command from the directory where the National Language Pack resides, after a DB2 Connect product has been installed.

The installation logs, *db2setup.log* and *db2setup.err* will be located, by default, in the */tmp* directory. You can specify the location of the log files.

If you want your DB2 product to have access to DB2 documentation either on your local computer or on another computer on your network, then you must install the DB2 Information Center. The DB2 Information Center contains documentation for the DB2 database and DB2 related products. See the “Installing the DB2 Information Center using the DB2 Setup wizard (UNIX)” topic in *Installing DB2 Servers* .

Installation requirements for DB2 Connect products (Solaris)

Before you install DB2 Connect products on Solaris Operating System, ensure that the system you choose meets the necessary operating system, hardware, software, and communications requirements.

To install a DB2 Connect product on Solaris, the following requirements must be met:

Table 6. Solaris installation requirements

Operating System	Hardware
Solaris 10 Update 5 <ul style="list-style-type: none">• 64-bit kernel• Patch 127128-11	Solaris x64 (Intel 64 or AMD64)
Solaris 9 <ul style="list-style-type: none">• 64-bit kernel• Patches 111711-12 and 111712-12• If raw devices are used, patch 122300-11 Solaris 10 Update 5 <ul style="list-style-type: none">• 64-bit kernel• If raw devices are used, patch 125100-07	UltraSPARC or SPARC64 processors

1. Support is only for DB2 to be installed on local zones. Installation on the global zone is not supported by DB2 at this time.

Operating system requirements

"Recommended & Security Patches" can be obtained from the <http://sunsolve.sun.com> Web site. From the SunSolve Online Web site, click on the "Patches" menu item in the left panel.

The J2SE Solaris Operating System Patch Clusters are also required. They can be obtained from the <http://sunsolve.sun.com> Web site.

For DB2 Connect on 64-bit Fujitsu PRIMEPOWER systems, you also require the following:

- Solaris 9 Kernel Update Patch 112233-01 or later to get the fix for patch 912041-01.

The Fujitsu PRIMEPOWER patches for the Solaris operating system can be downloaded from FTSI at: <http://download.ftsi.fujitsu.com/>.

For an additional list of issues that can affect DB2 database systems on Solaris, refer to: www.ibm.com/support/docview.wss?&uid=swg21257606

DB2 database products support Solaris ZFS filesystems and Logical Domains (LDoms).

Software requirements

- SUNWlibC software is required to install DB2 Connect on Solaris. It can be obtained from the <http://sunsolve.sun.com> Web site.
- A browser is required to view online help.

Communication requirements

You can use TCP/IP

- For TCP/IP connectivity, no additional software is required.
- DB2 Connect is supported on Sun Cluster 2.2 if:

- The protocol to the host is TCP/IP
- Two-phase commit is not used. This restriction is relaxed if the user configures the SPM log to be on a shared disk (this can be done through the **spm_log_path** database manager configuration parameter), and the failover system has an identical TCP/IP configuration (the same host name, IP address, and so on).

Mounting CDs or DVDs (Solaris Operating System)

If you are mounting the CD or DVD drive from a remote system using NFS, the CD or DVD file system on the remote computer must be exported with root access.

Depending on your local system configuration, you might also need root access on the local computer.

To mount the CD or DVD on Solaris Operating System:

1. Insert the CD or DVD into the drive.
2. If the Volume Manager (vold) is running on your system, the disc is automatically mounted as `/cdrom/cd_label` if the CD or DVD has a label or `/cdrom/unnamed_cdrom` if it is unlabeled.

If the Volume Manager is not running on your system, complete the following steps to mount the CD or DVD:

- a. Determine the name of the device by entering the following command:

```
ls -al /dev/sr* |awk '{print "/" $11}'
```

This command returns the name of the CD or DVD device. In this example, the command returns the string `/dev/dsk/c0t6d0s2`.

- b. Enter the following commands to mount the CD or DVD:

```
mkdir -p /cdrom/unnamed_cdrom
mount -F hsfs -o ro /dev/dsk/c0t6d0s2 /cdrom/unnamed_cdrom
```

where `/dev/dsk/c0t6d0s2` represents the name of the device that was returned in the preceding step and `/cdrom/unnamed_cdrom` represents the CD or DVD mount directory.

Note: If you are mounting the CD or DVD drive from a remote system using NFS, the CD or DVD file system on the remote machine must be exported with root access. You must also mount that file system with root access on the local machine.

3. Log out.

Your CD or DVD file system is now mounted. View the contents of the CD or DVD by placing the disk in the drive and enter the `cd /cdrom` command where `cdrom` is the mount point directory.

Chapter 12. Installing a DB2 Connect server product (Windows)

This task describes how to install a DB2 Connect server product, such as DB2 Connect Enterprise Edition on Windows operating systems using the DB2 Setup wizard. Alternatively, you can install DB2 Connect server products using the response file method.

Prerequisites

Before you launch the DB2 Setup wizard:

- Ensure that your system meets:
 - Disk and memory requirements
 - Hardware, distribution and software requirements
- If you are planning to use LDAP, you must refer to the “Extending the Active Directory Schema for LDAP directory services (Windows)” topic in *Installing DB2 Servers*.
- It is recommended that you use an Administrator account to perform the installation. The Administrator account must belong to the local administrator’s group on the Windows computer where you are installing your DB2 product and should have the following advanced user rights:
 - Act as part of the operating system
 - Create token object
 - Increase quotas
 - Replace a process level token

You can perform the installation without advanced user rights, but the setup program might be unable to validate accounts.

- If you want to install DB2 Connect with a non-Administrator account, refer to the topic, Non-Administrator installation of DB2 Connect (Windows).
- To install a DB2 Connect server product, such as DB2 Connect Enterprise Edition, on Windows using the DB2 Setup wizard:
 1. Log on to the system as a user with administrator authority.
 2. Close all programs so the installation program can update files as required.
 3. Insert the DVD into the drive. The auto-run feature automatically starts the DB2 Setup wizard. The DB2 Setup wizard will determine the system language and launch the setup program for that language. If you want to run the setup program in a different language, or the setup program failed to auto-start, you can run the DB2 Setup wizard manually.
 4. The DB2 Launchpad opens. From this window, you can view the installation prerequisites and the release notes, or you can proceed directly to the installation.
 5. Once you have initiated the installation, proceed by following the setup program’s prompts. Online help is available to guide you through the remaining steps. Click **Help** to invoke the online help. You can click **Cancel** at any time to exit the installation.

A log file stores general information and error messages resulting from the install and uninstall activities. The file name of the log follows the format

DB2-<Product Abbreviation>-<Date Time>.log, such as DB2-CEE-10-06-2006_17_23_42.log. By default, the log file is located in the My Documents\DB2LOG directory.

- To invoke the DB2 Setup wizard manually:
 1. Click **Start** and select the **Run** option.
 2. In the **Open** field, enter the following command:

```
x:\setup /i language
```

where:

- *x*: represents your DVD drive
 - *language* represents the territory code for your language (for example, EN for English).
3. Click **OK**.

If you want your DB2 product to have access to DB2 documentation either on your local computer or on another computer on your network, then you must install the DB2 Information Center. The DB2 Information Center contains documentation for the DB2 database and DB2 related products.

Installation requirements for DB2 Connect server products (Windows)

Before you install DB2 Connect server products on Windows operating systems, ensure that the system you choose meets the necessary operating system, hardware, software, and communications requirements.

To install a DB2 Connect server product, such as DB2 Connect Enterprise Edition, the following requirements must be met:

Hardware requirements

All Intel and AMD processors capable of running the supported Windows operating systems (32-bit and 64-bit)

Operating system requirements

One of:

- Windows XP Professional Edition (32-bit and 64-bit) with Service Pack 2 or later
- Windows 2003 with Service Pack 2 or later:
 - Standard Edition (32-bit and 64-bit)
 - Enterprise Edition (32-bit and 64-bit)
 - Datacenter Edition (32-bit and 64-bit)
- Windows Server 2008
 - Standard Edition (32-bit and 64-bit)
 - Enterprise Edition (32-bit and 64-bit)
 - Datacenter Edition (32-bit and 64-bit)

All Windows Server 2008 service packs are supported.

Software requirements

- MDAC 2.8 is required. The DB2 Setup wizard will install MDAC 2.8 if it is not already installed.
- A browser is required to view online help.

Communication requirements

- TCP/IP is supported and supplied by the operating system.

Windows (64-bit) considerations

- 32-bit UDFs and stored procedures are supported.

Required user accounts for installation of DB2 server products (Windows)

If you are installing a DB2 server product on Windows, you require the following user accounts:

- An installation user account and
- Optional - one or more setup user accounts. You can create these accounts during the installation.
 - A DB2 Administration Server (DAS) user account
 - A DB2 instance user account. You can also use the LocalSystem account for products other than DB2 Enterprise Server Edition.

The installation user account is the account of the user performing the installation. The installation user account must be defined before running the DB2 Setup wizard. The setup user accounts can be defined before installation or you can have the DB2 Setup wizard create them for you.

All user account names must adhere to your system naming rules and to DB2 User, user ID and group naming rules.

If you use an installation user account that contains non-English characters which are not specified in DB2 naming rules, the DB2 installation will fail.

Extended security on Windows

DB2 products offer extended Windows security. If the extended security feature is selected, you must add the users who will administer or use the DB2 product to either the DB2ADMNS or DB2USERS group as appropriate.

The DB2 installer creates these two new groups. You can either specify a new name or accept the default names during installation.

To enable this security feature, select the **Enable operating system security** check box on the **Enable operating system security for DB2 objects** panel during the DB2 installation. Accept the default values for the DB2 Administrators Group field, and the DB2 Users Group field. The default group names are DB2ADMNS and DB2USERS. If there is a conflict with existing group names, you will be prompted to change the group names. If required, you can specify your own group names.

DB2 server user accounts

Installation user account

A local or domain user account is required to perform the installation. Normally, the user account must belong to the *Administrators* group on the computer where you will perform the installation.

Alternatively, a non-Administrator user account can be used. This alternative requires that a member of the Windows Administrators group first configure the Windows elevated privileges settings to allow a non-Administrator user account to perform an installation.

On Windows 2008 and Windows Vista or higher, a non-administrator can perform an installation, but will be prompted for administrative credentials by the DB2 Setup wizard.

The user right "Access this computer from the network" is required for the installation user account.

The installation user ID must belong to the Domain Administrators group on the domain if the installation requires a domain account to be created or verified.

You may also use the built-in LocalSystem account as your Service Logon account for all products, except DB2 Enterprise Server Edition

User rights granted by the DB2 installer

The DB2 installation program does not grant the Debug Programs user right. The DB2 installer grants the following user rights:

- Act as part of the operating system
- Create token object
- Lock pages in memory
- Log on as a service
- Increase quotas
- Replace a process level token

DB2 Administration Server (DAS) user account

A local or domain user account is required for the DB2 Administration Server (DAS).

If you are performing a response file installation, you can also specify the Local System account in the response file. For more details, refer to the sample response files in the db2\windows\samples directory.

The LocalSystem account is available for all products, except DB2 Enterprise Server Edition and can be selected through the DB2 Setup wizard.

The DAS is a special DB2 administration service used to support the GUI tools and assist with administration tasks on local and remote DB2 servers. The DAS has an assigned user account that is used to log the DAS service on to the computer when the DAS service is started.

You can create the DAS user account before installing DB2 or you can have the DB2 Setup wizard create it for you. If you want to have the DB2 Setup wizard create a new domain user account, the user account you use to perform the installation must have authority to create domain user accounts. The user account must belong to the *Administrators* group on the computer where you will perform the installation. This account will be granted the following user rights:

- Act as part of the operating system
- Debug programs
- Create token object
- Lock pages in memory
- Log on as a service
- Increase quotas (adjust memory quotas for a process on Windows XP and Windows Server 2003 operating systems)
- Replace a process level token

If extended security is enabled, the DB2ADMNS group will have all these privileges. You can add users to that group and you do not need to add these privileges explicitly. However, the user still needs to be a member of the Local Administrators group.

The "Debug programs" privilege is only needed when DB2 group lookup is explicitly specified to use the access token.

If the user account is created by the install program, the user account will be granted these privileges and if the user account already exists, this account will also be granted these privileges. If the install grants the privileges, some of them will only be effective on first log on by the account that was granted the privileges or upon reboot.

It is recommended that the DAS user have SYSADM authority on each of the DB2 systems within your environment so that it can start or stop other instances if required. By default, any user that is part of the *Administrators* group has SYSADM authority.

DB2 instance user account

The user account must belong to the *Administrators* group on the computer where you will perform the installation.

A local or domain user account is required for the DB2 instance. Every DB2 instance has one user that is assigned when the instance is created. DB2 logs on with this user name when the instance is started. An error will occur if you use a domain user account to perform a database operation (such as, creating a database) against a DB2 instance created with either a Local user account or the LocalSystem account. If you know you will be using a domain user account, you should create the instance using a domain user account.

You may also use the built-in LocalSystem account to run the installation for all products, except for DB2 Enterprise Server Edition.

You can create the DB2 instance user account before installing DB2 or you can have the DB2 Setup wizard create it for you. If you want to have the DB2 Setup wizard create a new domain user account, the user account you use to perform the installation must have authority to create domain user accounts. This account will be granted the following user rights:

- Act as part of the operating system
- Debug programs
- Create token object
- Increase quotas
- Lock pages in memory
- Log on as a service
- Replace a process level token

If extended security is enabled, then the DB2ADMNS group will have all these privileges. You can add users to that group and you do not need to add these privileges explicitly. However, the user still needs to be a member of the Local Administrators group.

The "Debug programs" privilege is only needed when DB2 group lookup is explicitly specified to use the access token.

If the user account is created by the install program, the user account will be granted these privileges and if the user account already exists, this account will also be granted these privileges. If the install grants the

privileges, some of them will only be effective on first log on by the account that was granted the privileges or upon reboot.

Extending the Active Directory Schema for LDAP directory services (Windows)

If you plan to use the Lightweight Directory Access Protocol (LDAP) directory server feature with Windows Server 2003, you have to extend the Active Directory schema to contain DB2 object classes and attribute definitions using the db2schex command.

Extending the directory schema prior to installing DB2 products and creating databases provide the following benefits:

- The default DB2 instance, created during the installation, is cataloged as a DB2 node in Active Directory, provided that the installation user ID had sufficient privileges to write to Active Directory.
- Any databases created after installation is automatically cataloged into Active Directory.

To extend the directory schema:

1. Log onto any machine that is part of the Windows domain with a Windows user account that has Schema Administration authority.
2. Run the db2schex command from the installation DVD . You can run this command without logging off and logging on again, as follows:

```
runas /user:MyDomain\Administrator x:\db2\Windows\utilities\db2schex.exe
```

where x: represents the DVD drive letter.

When db2schex completes, you can proceed with the installation of your DB2 product; or if you have already installed DB2 products or created databases, you have to manually register the node and catalog the databases. For more information, see the “Enabling LDAP support after DB2 installation is complete” topic.

Non-Administrator installation of DB2 Connect (Windows)

For a non-Administrator’s installation, the account you are logged on as must belong to Power Users group.

Some information about DB2 Connect that must appear in the registry must be entered in the HKEY_CURRENT_USER folder in the registry. Although many items will be stored under the HKEY_LOCAL_MACHINE folder in the registry for non-Administrator installations of DB2 Connect, the environment settings must be changed in HKEY_CURRENT_USER.

A member of the Windows Administrators group must configure the Windows elevated privileges settings to allow a non-Administrator user account to perform an installation. For example, on a 64-bit operating system you must manually grant full permission on HKLM\Software\Wow6432Node before a 32-bit DB2 Connect Personal Edition product can be successfully installed.

Note: If a non-Administrator user account is going to do the product installation, then the VS2005 runtime library must be installed before attempting to install a DB2 product. The VS2005 runtime library is needed on the operating system before

the DB2 product can be installed. The VS2005 runtime library is available from the Microsoft runtime library download web site. There are two choices: choose `vcredist_x86.exe` for 32-bit systems or `vcredist_x64.exe` for 64-bit systems.

System shortcuts must be changed to user shortcuts for the non-Administrator install. Moreover, since services are required to install any of the DB2 Connect products, but cannot be created without administrative authority, services that would be automatically started are run as processes when a non-administrator installs.

The following are installation situations you might encounter in an environment where both administrator and non-administrator installations exist:

- A non-Administrator has installed DB2 Connect, and then an Administrator attempts to install DB2 Connect on the same system. The Administrator will get a message that the product is already installed. The Administrator does have the authority to uninstall and reinstall the product to get around this issue.
- A non-administrator has installed DB2 Connect, and then a second non-Administrator attempts to install DB2 Connect on the same system. In this scenario, the installation will fail, and return an error message that the user must be an Administrator to install the product.
- An Administrator has installed DB2 Connect, and then a non-Administrator attempts to install DB2 Connect on the same system. In this scenario, the install will fail, and return an error message that the user must be an Administrator to install the product. An Administrator always has the authority to uninstall or reinstall.
- Non-Administrator users cannot uninstall a DB2 product. Those non-Administrator users on a Windows Vista (and later) operating system **can** uninstall a DB2 product.

Adding your user ID to the DB2ADMNS and DB2USERS user groups (Windows)

After successfully completing a DB2 installation, you now have to add users to the DB2ADMNS or the DB2USERS groups for users that need to run local DB2 applications and tools on the machine. The DB2 installer creates two new groups. You can either use a new name or accept the default names. The default group names are DB2ADMNS and DB2USERS.

Prerequisites

- You must have installed a DB2 product.
- You must have selected the Enable operating system security check box on the Enable operating system security for DB2 object panel during the installation of your DB2 product.

To add users to the appropriate group:

1. Click **Start** and select **Run**.
2. Type `lusrmgr.msc` and click **OK**.
3. Select **Local Users and Groups**.
4. Select **Users**.
5. Select the user you want to add.
6. Click **Properties**.
7. Click the **Member Of** tab.

8. Click **Add**.
9. Select the appropriate group.
10. Click **OK**.

If you did the install and chose not to enable the new security feature you can still do so post-install by running the `db2extsec.exe` command. Adding a user to a group takes effect the first time the user logs on after the user has been added. For example, if you add your user ID to the DB2ADMNS group, you need to log out and then log in again for this change to take effect.

Chapter 13. Non-root installation overview (Linux and UNIX)

Before Version 9.5, you could install products, apply and roll back fix packs, configure instances, add features, or uninstall products only if you had root privileges. Now, if you are a non-root user, you can perform these tasks on Linux and UNIX platforms.

The DB2 installer automatically creates and configures a non-root instance during a non-root installation. As a non-root user, you can customize the configuration of the non-root instance during the installation. You can also use and maintain the installed DB2 product without root privileges.

The non-root installation of a DB2 product has one DB2 instance with most features enabled by default.

A non-root installation can be attractive for many groups, such as the following ones:

- Enterprises that have thousands of workstations and users who want to install a DB2 product without consuming a system administrator's time
- Application developers who are not typically system administrators but use DB2 products to develop applications
- Independent Software Vendors (ISVs) who develop software that does not require root authority yet embeds a DB2 product

Although non-root installations have most of the function of root installations, there are some differences and limitations. You can lift some of the limitations by having a root user run the `db2rfe` command.

Differences between root installations and non-root installations

In addition to a few limitations, the directory structure of a non-root installation is slightly different than the directory structure of a root installation.

During a root installation, subdirectories and files for the DB2 product are created in a directory of the root user's choosing.

Unlike root users, non-root users cannot choose where DB2 products are installed. Non-root installations are always placed in the `$HOME/sql1ib` directory, where `$HOME` represents the non-root user's home directory. The layout of the subdirectories within the `sql1ib` directory of a non-root is similar to that of a root installation.

For root installations, multiple instances can be created. Instance ownership is associated with the user ID under which the instance was created.

Non-root installations can have only one DB2 instance. The non-root installation directory contains all of the DB2 product files and instance files with no soft links.

The following table summarizes the differences between root installations and non-root installations.

Table 7. Differences between root installations and non-root installations

Criteria	Root installations	Non-root installations
User can select installation directory	Yes	No. DB2 products are installed under the user's home directory.
Number of DB2 instances allowed	Multiple	One
Files deployed during installation	Program files only. Instances must be created after installation.	Program files and instance files. The DB2 product is ready for use immediately after installation.
Upgrade version and instance	No	No need to uninstall the old version before installing the new version. Install new version, and upgrade the instance, together.

Limitations of non-root installations

In addition to the differences between root installations and non-root installations, there are several limitations on non-root installations. This topic discusses the limitations to help you decide if you want to use a non-root installation.

Product limitations

Some DB2 products are not supported in non-root installations:

- DB2 Query Patroller
- DB2 Net Search Extender
- Locally installed DB2 Information Center

Note: The locally installed DB2 Information Center is not supported in non-root installations because it requires root authority to start the daemon. However, a non-root-installation DB2 instance can be configured to use a locally installed DB2 Information Center if it is installed on the same computer.

Features and tools limitations

The following features and tools are not available in non-root installations:

- The DB2 Administration Server (DAS) and its associated commands: `dasprt`, `dasdrop`, `daslist`, `dasmigr`, and `dasupdt`
- The Configuration Assistant
- The Control Center
- The ability for the `db2governor` to increase priority is not supported
- In the Work Load Manager (WLM), attempts to set agent priority in a DB2 service class in a non-root DB2 instance are allowed. However, the agent priority will not be respected, and no `SQLCODE` error is returned.
- Automatic starting of non-root DB2 instances at system reboot is not supported

Health monitor limitations

The following health monitor features are not supported in non-root installations:

- Running script or task actions on alert occurrences
- Sending alert notifications

Partitioned database limitation

Only single-partition databases are supported in non-root installations. You cannot add additional database partitions.

Listing DB2 products

The output produced by the `db2ls` command, when run as a non-root user, is different than the output produced when run as a root user. For details, refer to the `db2ls` command topic.

DB2 copies

Each non-root user can have only one copy of a DB2 product installed.

DB2 instance limitation

In non-root installations, one DB2 instance is created during installation. Additional instances cannot be created.

DB2 instance actions can be performed only by the instance owner

Root installations and non-root installations can coexist on the same computer in different installation paths. However, a non-root instance can be updated, or dropped (using the `db2_deinstall` command), only by the non-root user who owns the non-root instance.

A DB2 instance created by a user with root privilege can be updated or dropped only by a user with root privilege.

DB2 instance commands

The following DB2 instance commands are unavailable in non-root installations:

db2icrt

When installing a DB2 product as a non-root user, a single instance is automatically created and configured. Further instances cannot be created in non-root installations. However, if the automatically created instance needs to be configured, you can use the non-root install configuration command, `db2nrcfg`.

db2iupdt

The `db2iupdt` command cannot be used for non-root instances. Instead, use the non-root install configuration command (`db2nrupdt`) to update the non-root DB2 instance. However, updating the non-root instance is normally not required because it gets updated automatically when updating your DB2 product.

db2idrop

The instance that gets automatically created during non-root installations cannot be dropped. The DB2 product must be uninstalled to drop the DB2 instance.

db2iupgrade

Upgrading is not supported for non-root installations. To upgrade a non-root instance, use the `db2nrupgrade` command.

Upgrading limitation

Root instances cannot be upgraded to a non-root instance.

Post-installation actions can be performed only by the DB2 instance owner

Root installations and non-root installations can coexist on the same computer. However, only the original non-root user who installed the DB2 product can perform subsequent actions such as:

- Applying fix packs
- Adding features

- Installing add-on products

Adjusting ulimit values

The ulimit command on UNIX and Linux sets or reports user resource limits, such as data and stack limits. For root instances, the database server dynamically updates required ulimit settings without changing the permanent settings. However, for non-root instances, the ulimit settings can only be checked during installation. A warning message is displayed if the settings are inadequate. Root authority is required to change the ulimit settings.

Limitations that can be overcome by running db2rfe

There are further limitations on non-root installations which can be overcome by running the db2rfe command. The following features and abilities are initially unavailable in non-root installations:

- Operating system-based authentication
- High Availability (HA) feature
- The ability to reserve service names in the /etc/services file
- The ability to increase user data limits (ulimits). This ability applies only to AIX. On other platforms, user data limits must be increased manually.

Run the Enable root features for non-root install command (db2rfe) to enable these features and abilities. Running the db2rfe command is optional, and must be run by a user with root authority.

Authentication type in non-root installations

Operating system-based authentication is the default authentication type for DB2 products. Since non-root installations do not support operating system-based authentication, if you choose not to run the db2rfe command after installing your DB2 product as a non-root user, then you must manually set the authentication type. You can do so by updating the following parameters in the database manager configuration (dbm cfg) file:

- clnt_pw_plugin (Client userid-password plug-in configuration parameter)
- group_plugin (Group plug-in configuration parameter)
- srvcon_pw_plugin (Userid-password plug-in for incoming connections at the server configuration parameter)

Installing a DB2 product as a non-root user

Most DB2 database products can be installed as a non-root user.

Before you begin

Before you install any DB2 database product as a non-root user, be aware of the differences between root installations and non-root installations, and the limitations of non-root installations. For more information on non-root installation, see “Non-root installation overview (Linux and UNIX)”.

Prerequisites for installing a DB2 database product as a non-root user are:

- You must be able to mount the installation DVD, or have it mounted for you.
- You must have a valid user ID that can be used as the owner of a DB2 instance.

User IDs have the following restrictions and requirements:

- Must have a primary group other than guests, admins, users, and local
- Can include lowercase letters (a-z), numbers (0-9), and the underscore character (_)
- Cannot be longer than eight characters
- Cannot begin with IBM, SYS, SQL, or a number
- Cannot be a DB2 reserved word (USERS, ADMINS, GUESTS, PUBLIC, or LOCAL), or an SQL reserved word
- Cannot use any User IDs with root privilege for the DB2 instance ID, DAS ID or fenced ID.
- Cannot include accented characters
- If existing user IDs are specified instead of creating new user IDs, make sure that the user IDs:
 - Are not locked
 - Do not have expired passwords
- The hardware and software prerequisites that exist for the product you are installing apply to the non-root user just as they do for root users.
- On AIX Version 5.3, Asynchronous I/O (AIO) must be enabled. It is strongly recommended the system has I/O Completion Ports (IOCP) enabled.
- Your home directory must be a valid DB2 path.
DB2 installation paths have the following rules:
 - Can include lowercase letters (a-z), uppercase letters (A-Z), and the underscore character (_)
 - Cannot exceed 128 characters
 - Cannot contain spaces
 - Cannot contain non-English characters

About this task

Installing DB2 database products as a non-root user is transparent to the non-root user. In other words, there is nothing special a non-root user needs to do to install a DB2 database product, other than being logged being logged in as a non-root user.

Procedure

To perform a non-root installation:

1. Log in as a non-root user
2. Install your DB2 database product using any of the methods available to you.
Options include:
 - The DB2 Setup wizard (GUI install)
 - The db2_install command
 - The db2setup command with a response file (silent install)

Note: Since non-root users cannot choose the directory where DB2 database products are installed, any **FILE** keyword in your response file is ignored.

3. After the DB2 database product is installed, you must open a new login session to use the non-root DB2 instance. Alternatively, you can use the same login session if you set up the DB2 instance environment with `$HOME/sqllib/db2profile` (for Bourne shell and Korn shell users) or `$HOME/sqllib/db2chsrc` (for C shell users), where `$HOME` is the non-root user's home directory.

What to do next

After the DB2 database product is installed, verify your operating system user process resource limits (ulimits). If the minimum ulimit values are not met, the DB2 engine can encounter unexpected operating resource shortage errors. These errors can lead to a DB2 database system outage.

Enabling root-based features in non-root installations with db2rfe

There are several features and abilities in non-root installations that are initially unavailable but can be enabled by running the db2rfe command

This task requires root authority.

To enable the features and abilities that are initially unavailable in non-root installations:

1. Locate the sample configuration files. Two sample configuration files are provided:
 - `$HOME/sql11ib/instance/db2rfe.cfg` is pre-configured with default values for the non-root DB2 instance
 - `$HOME/sql11ib/cfg/db2rfe.cfg.sample` is not configuredwhere `$HOME` is the non-root user's home directory.
2. Copy one of the sample configuration files to a different location so the original file remains unaltered.
3. Update the copied configuration file as needed. This configuration file is input to the db2rfe command. An example of a configuration file is:

```
INSTANCENAME=db2inst2
SET_ULIMIT=NO
ENABLE_HA=NO
ENABLE_OS_AUTHENTICATION=NO
RESERVE_REMOTE_CONNECTION=NO
  **SVCENAME=db2c_db2inst2
  **SVCEPORT=48000
RESERVE_TEXT_SEARCH_CONNECTION=NO
  **SVCENAME_TEXT_SEARCH=db2j_db2inst2
  **SVCEPORT_TEXT_SEARCH=55000
```

Note:

- The value for the **INSTANCENAME** parameter is filled in automatically by DB2 installer
- The **SET_ULIMIT** parameter is available only on AIX. On other operating systems, a user with root authority needs to set ulimit values manually.
- The default value for the other keywords is NO
- Child parameters (such as **SVCENAME**) are commented out by default. Comments are denoted with ******
- If you set a parameter to YES, and if it has any child parameters, it is recommended that you uncomment the child parameters and provide appropriate values. Any port values that are provided are examples. Ensure the port values you assign are free.

An example is provided below to show an edited configuration file that will enable the following features and abilities:

- High availability
- Operating system-based authentication

- DB2 Text Search, with a service name of **db2j_db2inst2** and a port value of **55000**

To enable these features and abilities, edit the configuration file as follows:

```

INSTANCENAME=db2inst2
SET_ULIMIT=NO
ENABLE_HA=YES
ENABLE_OS_AUTHENTICATION=YES
RESERVE_REMOTE_CONNECTION=NO
  **SVCENAME=db2c_db2inst2
  **SVCEPORT=48000
RESERVE_TEXT_SEARCH_CONNECTION=YES
  SVCENAME_TEXT_SEARCH=db2j_db2inst2
  SVCEPORT_TEXT_SEARCH=55000

```

4. Log in as a user with root authority
5. Navigate to the `$HOME/sqllib/instance` directory, where `$HOME` represents the non-root user's home directory.
6. Run the `db2rfe` command using the following syntax:

```
db2rfe -f config_file
```

where *config_file* is the configuration file created in Step 3 on page 76.

To keep root-based features enabled on non-root installations, rerun the `db2rfe` command after applying fix packs or upgrading to a new version.

Applying fix packs to a non-root installation

The task of applying fix packs to a non-root installation is essentially the same as applying fix packs to a root installation, with a few exceptions.

Before applying fix packs to a non-root installation, you must log on with the user ID that was used to install the non-root installation.

If you enabled root features in your non-root installation using the `db2rfe` command, you should locate the configuration file that was used when running the `db2rfe` command. That configuration file will be needed to re-enable the root features after you apply the fix pack.

To apply a fix pack to a non-root installation:

1. Apply your fix pack according to the Applying fix packs topic.

Note: The `installFixPack` command's `-b` option is invalid for non-root installations.

2. Optional: Run the `db2rfe` command. If you had root-based features enabled in your non-root installation, and if you want to re-enable those features, the `db2rfe` command must be rerun. Running this command requires root authority.

Note: If you edited `$HOME/sqllib/instance/db2rfe.cfg` when you first enabled root features, that configuration file will not have been overwritten when applying the fix pack, so you can reuse that file when running the `db2rfe` command. However, you should also check `$HOME/sqllib/cfg/db2rfe.cfg.sample`. If the fix pack introduced any new root features available to non-root installations, `$HOME/sqllib/cfg/db2rfe.cfg.sample` shows the new features.

Removing non-root DB2 products using db2_deinstall (Linux and UNIX)

This task provides steps for removing non-root DB2 products or components using the `db2_deinstall` command.

You must stop the non-root instance before running the `db2_deinstall` command.

Note:

- This task applies to DB2 products that were installed without root authority. A separate task exists for uninstalling DB2 products that were installed with root authority.
- As with root users, non-root users can use the `db2_deinstall` command to uninstall DB2 products. The `db2_deinstall` command for non-root installations has the same options as root installations, and has an extra option: `-f sqllib`.
- It is important to note that running `db2_deinstall` as a non-root user uninstalls the DB2 product *and* drops the non-root instance. This is different than root installations, where running `db2_deinstall` only uninstalls the DB2 program files.
- You cannot remove DB2 products using a native operating system utility, such as `rpm` or `SMIT`.

To uninstall a DB2 product that was installed by a non-root user:

1. Log in with the user ID that was used to install the DB2 product.
2. Navigate to the `$HOME/sqllib/install` directory, where `$HOME` is your home directory.
3. Run the `db2_deinstall` command.

Note:

- If you run the `db2_deinstall` command with the `-a` option, the DB2 program files are removed, but any configuration files are left behind in a backup directory called `sqllib_bk`.
- If you run the `db2_deinstall` command with the `-a -f sqllib` option, the entire `sqllib` subdirectory in your home directory will be removed. If you have any files in `sqllib` you want to keep, be sure to copy them elsewhere before running `db2_deinstall -a -f sqllib`.
- As with root installations, running the `db2_deinstall` command with the `-F` option against a non-root installation allows the non-root user to remove specific DB2 features.

Part 6. Postinstallation tasks

Chapter 14. License key activation

During the installation of licensed DB2 Connect server products, the installation program registers the DB2 Connect licenses. However, if you need to manually activate a license for your DB2 Connect product, you can use either the DB2 License Center or the `db2licm` command.

DB2 license files

There are two types of license files associated with DB2 database products: *base license keys* and *full license keys*. These license keys are stored in plaintext files, which are generally referred to as *license files* or *license entitlement certificates*.

A “base” license does not confer any usage rights. It is included in the DB2 database product installation media and is applied automatically during the installation process. For example, `db2ese.lic` is a base license file for DB2 Enterprise Server Edition .

License keys are required for all DB2 database products (including DB2 Connect) and for each optional database feature. The license key is found in the `/db2/license` directory of the Activation CD, which is supplied as a part of the product installation media. For example, `db2ese_u.lic` is a license key and can be found on the *DB2 Enterprise Server Edition for Linux, UNIX, and Windows - Authorized User Option Activation CD*. By default, license keys are not applied during the DB2 database product installation. However, the following products do not have an Activation CD, therefore their license is automatically applied during the installation process: DB2 Express-C and DB2 Connect Personal Edition. In addition, DB2 Personal Edition is also a special case. Although DB2 Personal Edition has an Activation CD, its license is also automatically applied during installation.

For a list of license files, refer to Table 8 on page 82.

In general, licenses for DB2 database products can be purchased either per processor (priced by processor value unit (PVU)) or by authorized user. There are also limited use virtual server and limited use socket charge metrics for DB2 Express™ Edition and DB2 Workgroup Server Edition, respectively. The DB2 Storage Optimization feature is an exception. Since it can only be purchased by PVU (and only if the underlying database system is also licensed by PVU).

If you purchased a DB2 database product as well as separately priced features, you will need to apply more than one license key. Each DB2 database product and DB2 feature has its own license key. All of the features must be acquired under the same charge metric as the underlying DB2 database product. For example, if you purchase DB2 Enterprise Server Edition with a per processor license, you would need to purchase the DB2 Performance Optimization Feature by processor as well.

If you downloaded a DB2 database product or feature from one of the following Web sites and you do not have an Activation CD, you can obtain license keys as follows:

- Passport Advantage®: You can obtain an Activation CD image from the Passport Advantage Web site: <http://www.ibm.com/software/lotus/passportadvantage/>. When using Passport Advantage, you must download the Activation CD image for each product and feature separately.
- PartnerWorld®: Contact PartnerWorld for the appropriate license key. Refer to the PartnerWorld Web site: http://www.ibm.com/partnerworld/pwhome.nsf/weblook/index_pub.html
- The DB2 support or fix central Web sites: If you have not purchased a license key, contact an IBM Sales representative.

Once you have obtained the appropriate license keys, you should apply them before you use the DB2 database product. This is also referred to as registering the license key or adding a license. As a mechanism for you to keep track of, and differentiate, the DB2 database products and features you have installed on your system, it is recommended that you register the license key for your DB2 database products. You can find the DB2 database product license terms at: <http://www.ibm.com/software/sla>.

The management of licenses for DB2 database products or features is done through either:

- the db2licm license management tool command, or,
- the License Center within the Control Center.

Table 8. DB2 license files

License file name	DB2 database product or feature
db2aac.lic	DB2 Advanced Access Control feature
db2conpe.lic	DB2 Connect Personal Edition
db2consv.lic	DB2 Connect Server (Unlicensed base)
db2consv_as.lic	DB2 Connect Application Server Edition
db2consv_ee.lic	DB2 Connect Enterprise Edition
db2consv_is.lic	DB2 Connect Unlimited Edition for System i
db2consv_zs.lic	DB2 Connect Unlimited Edition for System z
db2dede.lic	IBM Database Enterprise Developer Edition
db2dpf.lic	DB2 Database Partitioning feature
db2ese.lic	DB2 Enterprise Server Edition (Unlicensed base)
db2ese_c.lic	DB2 Enterprise Server Edition (CPU option)
db2ese_u.lic	DB2 Enterprise Server Edition (Authorized User option)
db2exp.lic	DB2 Express Edition (Unlicensed base)
db2exp_c.lic	DB2 Express Edition (CPU option)
db2exp_s.lic	DB2 Express Edition (Server option)
db2exp_sftl.lic	DB2 Express Edition (Server option Fixed Term License)
db2exp_u.lic	DB2 Express Edition (Authorized User option)
db2exp_uftl.lic	DB2 Express Edition (Authorized User Option Fixed Term License)
db2expc_uw.lic	DB2 Express-C (Unwarranted)

Table 8. DB2 license files (continued)

License file name	DB2 database product or feature
db2geo.lic	DB2 Geodetic Data Management feature
db2hrese.lic	IBM Homogeneous Replication Feature for DB2 Enterprise Server Edition
db2haexp.lic	IBM DB2 High Availability Feature for Express Edition
db2pe.lic	DB2 Personal Edition
db2poese.lic	IBM DB2 Performance Optimization Feature for Enterprise Server Edition
db2so.lic	DB2 Storage Optimization feature
db2wse.lic	DB2 Workgroup Server Edition (Unlicensed base)
db2wse_c.lic	DB2 Workgroup Server Edition (CPU option)
db2wse_sk.lic	DB2 Workgroup Server Edition (Limited Use Socket Option)
db2wse_u.lic	DB2 Workgroup Server Edition (Authorized User option)
bwdb2.lic	Base Warehouse Feature for DB2
ewdb2.lic	Enterprise Warehouse Feature for DB2
db2dp_sk.lic	IBM InfoSphere™ Warehouse Departmental Edition - Limited Use Socket Option
db2dpb_sk.lic	IBM InfoSphere Warehouse Departmental Base Edition - Limited Use Socket Option
iwebe.lic	IBM InfoSphere Warehouse Enterprise Base Edition
iwde.lic	IBM InfoSphere Warehouse Developer Edition
iwdpb_u.lic	IBM InfoSphere Warehouse Departmental Base Edition – Authorized User Option
iwdp_u.lic	IBM InfoSphere Warehouse Departmental Edition – Authorized User Option
iwee.lic	IBM InfoSphere Warehouse Enterprise Edition
sam31.lic	IBM Tivoli® System Automation for Multiplatforms (SA MP)

If you have license files that end in `_t.lic`, they are trial licenses.

Using the License Center

Registering a DB2 database product or feature license key using the License Center

From the License Center, use the Add License window to add new licenses on Linux or Windows operating systems. This action is also referred to as applying license entitlement certificates or adding a license.

Before you begin

To complete this task, you must have the appropriate license file (*.lic).

On Linux operating systems, the instance owner must have read and execute privileges on the directory where the license files are located.

About this task

Important: The License Center has been deprecated in Version 9.7 and might be removed in a future release. For more information, see the “Control Center tools and DB2 administration server (DAS) have been deprecated” topic in the *What’s New for DB2 Version 9.7* book.

Procedure

To register a DB2 license key:

1. Click  in the Control Center to open the License Center. Select the system for which you want to add a new license.
2. Select an instance.
3. The **Installed Products** field will display the name of the products that you have installed. Select a product.
4. Select **Add** from the **License** menu. The Add License dialog opens.
5. Select the license key (*.lic) that you want to add.
6. Click **OK** to add the license key.

Results

The license information is refreshed immediately in the License Center.

Setting the DB2 license policy using the License Center

For DB2 Connect Enterprise Edition the license policy controls and monitors the number of users that can connect simultaneously to a DB2 Connect server. For InfoSphere Replication Server or InfoSphere Federation Server, the license policy controls and monitors the number of connectors to a non-DB2 data source.

Important: The License Center has been deprecated in Version 9.7 and might be removed in a future release. For more information, see the “Control Center tools and DB2 administration server (DAS) have been deprecated” topic in the *What’s New for DB2 Version 9.7* book.

To set your license policy using the License Center, perform the following depending on the type of licenses that you purchased:

1. In the License Center, select **Change** from the **License** menu.
2. In the Change License window, select the type of license that you have purchased. For example:
 - If you purchased a InfoSphere Replication Server or InfoSphere Federation Server Concurrent Connector policy, select **Connector** and enter the number of connector licenses that you purchased.
 - If you purchased a DB2 Connect Server Concurrent User license, select **Concurrent users** or **Concurrent connect users** and enter the number of user licenses that you have purchased.

Using the db2licm command

Registering a DB2 product or feature license key using the db2licm command

Use the db2licm command to apply the license entitlement certificate (also referred to as registering a license key).

Before you begin

To complete this task, you must have the appropriate license file (*.lic).

On Windows operating systems, you must belong to the local Administrators or Power Users group to use the db2licm command with the **-a** command parameter.

Procedure

- On Windows operating systems, register a DB2 license key by entering the following command:

```
db2instance_path\bin\db2licm -a filename
```

where *db2instance_path* is where the DB2 instance was created and *filename* is the full path name and file name for the license file that corresponds to the product or feature you have purchased.

- On Linux or UNIX operating systems, register a DB2 license key by entering the following command:

```
INSTHOME/sql1lib/adm/db2licm -a filename
```

where *INSTHOME* represents the home directory of the instance owner and *filename* is the full path name and file name for the license file that corresponds to the product or feature you have purchased. The db2licm command can also be found in the path where the DB2 database product is installed. For example, /opt/IBM/db2/V9.7/adm on AIX, HP-UX or Solaris operating systems or /opt/ibm/db2/V9.7/adm on Linux operating systems, if you use the default installation directory.

Setting the DB2 license policy using the db2licm command

For DB2 Connect Enterprise Edition the license policy controls and monitors the number of users that can connect simultaneously to a DB2 Connect server.

For InfoSphere Replication Server or InfoSphere Federation Server, the license policy controls and monitors the number of connectors to a non-DB2 data source.

1. Before you set your license policy using the db2licm command, you need the product identifier. To list the product identifier information, enter the following command:

```
db2licm -l
```

The product identifier is listed in the Product Identifier field.

2. To set your license policy, perform *one* of the following depending on the type of licenses that you purchased. For example:

- If you purchased a InfoSphere Replication Server or InfoSphere Federation Server Concurrent Connector policy, enter the following command:

```
db2licm -c isrs concurrent
```

or

```
db2licm -c isfs concurrent
```

- If you purchased a DB2 Connect Server Concurrent User policy, enter the following command:

```
db2licm -p db2consv concurrent
```

Chapter 15. Applying fix packs

It is recommended that you keep your DB2 database environment running at the latest fix pack level to ensure problem-free operation. To install a fix pack successfully, perform all of the necessary preinstallation and post-installation tasks.

About this task

A DB2 fix pack contains updates and fixes for problems (Authorized Program Analysis Reports, or "APARs") found during testing at IBM, as well as fixes for problems reported by customers. The APARLIST.TXT file describes the fixes contained in each fix pack and it is available for download at <ftp://ftp.software.ibm.com/ps/products/db2/fixes/english-us/aparlist/>.

Fix packs are cumulative. This means that the latest fix pack for any given version of DB2 contains all of the updates from previous fix packs for the same version of DB2.

The fix pack images available are:

- A single server image.

The single server image contains the new and updated code required for all DB2 database server products and the IBM Data Server Client. If more than one DB2 database server product is installed in a single location, the DB2 database server fix pack applies maintenance code updates to all the installed DB2 database server products. The Data Server Client fix pack is contained within the one DB2 database server fix pack (namely the fix pack that can service any one of the following database server products: DB2 Enterprise Server Edition, DB2 Workgroup Server Edition, DB2 Express Edition, DB2 Personal Edition, DB2 Connect Enterprise Edition, DB2 Connect Application Server Edition, DB2 Connect Unlimited Edition for zSeries, and DB2 Connect Unlimited Edition for i5/OS). You can use the DB2 database server fix pack to upgrade a Data Server Client.

A single server image can also be used to install any of the DB2 database server products, at a particular fix pack level, with a DB2 try and buy license by default.

- A fix pack for each of the other DB2 database products.

Use this fix pack only if you only have non-server database products or add-on products installed. For example, IBM Data Server Runtime Client or DB2 Query Patroller.

Do not use this type of fix pack if the installed DB2 database products are only DB2 database server products or a Data Server Client. Instead, use the single server image fix pack.

For Windows platforms, if you have more than one DB2 database product (which includes at least one product that is not a Data Server Client or a DB2 database server) installed in a single DB2 copy, you must download and uncompress all of the corresponding product-specific fix packs before starting the fix pack installation process.

- A universal fix pack.

The universal fix pack services installations where more than one DB2 database product has been installed.

The universal fix pack is not needed if the installed DB2 database products are only DB2 database server products or a Data Server Client. In this case, the single server image fix pack should be used.

On Linux or UNIX operating systems, if national languages have been installed, you also require a separate national language fix pack. The national language fix pack can not be installed alone. A universal or product-specific fix pack must be applied at the same time and they must both be at the same fix pack level. For example, if you are applying a universal fix pack to non-English DB2 database products on Linux or UNIX, you must apply both the universal fix pack and the national language fix pack to update the DB2 database products.

Restrictions

- A DB2 Version 9.7 fix pack can only be applied to DB2 Version 9.7 general availability (GA) or DB2 Version 9.7 fix pack copies.
- All DB2 instances, DAS, and applications related to the DB2 copy being updated must be stopped before installing a fix pack.
- In a partitioned database environment, prior to installing the fix pack, you must stop the database manager on all database partition servers. You must install the fix pack on the instance-owning database partition server and all other database partition servers. All computers participating in the instance must be updated to the same fix pack level.
- On Linux or UNIX operating systems:
 - If you have DB2 database products on a Network File System (NFS), you must ensure the following are stopped completely before installing the fix pack: all instances, the DB2 administration server (DAS), interprocess communications (IPC), and applications on other machines using the same NFS mounted installation.
 - If the system commands `fuser` or `lsof` are not available, the `installFixPack` command cannot detect loaded DB2 files. You must ensure no DB2 files are loaded and provide an override option to install the fix pack. On UNIX, the `fuser` command is required to check for loaded files. On Linux, either the `fuser` command or `lsof` command is required.
For details on the override option, see the `installFixPack` command.
- On client applications, after a fix pack has been applied, to perform autobind of applications, the user must have bind authority.
- Logically detached data partitions are not supported in releases earlier than DB2 V9.7 Fix Pack 1. A data partition is temporarily placed in the logically detached state while it is being detached from a data partitioned table. A partition is in the logically detached state when, in `SYSCAT.DATAPARTITIONS`, the `STATUS` of the partition is set to 'L' (`SYSCAT.DATAPARTITIONS.STATUS='L'`). If you are reverting to a release earlier than DB2 V9.7 Fix Pack 1, ensure that data partitions are not logically detached before reverting to the release.
- For tables that use multidimensional clustering (MDC) and data partitioning, the system-created partitioned block indexes are not supported in releases earlier than DB2 V9.7 Fix Pack 1. When reverting to a release earlier than DB2 V9.7 Fix Pack 1, data-partitioned MDC tables that use partitioned block indexes must be dropped before reverting to the release and recreated after reverting to the release.
- Distribution statistics for XML data are not supported in releases earlier than DB2 V9.7 Fix Pack 1. After you revert to a release earlier than DB2 V9.7 Fix Pack 1, issue the `RUNSTATS` command on tables where XML distribution statistics were collected to refresh the statistics for the tables.

- Installation of a DB2 fix pack will not service IBM Data Studio Administration Console or IBM Data Studio.
- Partitioned indexes over XML data are not supported in releases earlier than DB2 Version 9.7 Fix Pack 1. If you are reverting partitioned indexes over XML data to a release earlier than DB2 Version 9.7 Fix Pack 1, prior to reverting to the release, you must drop the partitioned indexes and re-create them as nonpartitioned indexes.

Procedure

To install a fix pack:

1. Check fix pack prerequisites.
2. Perform the necessary tasks prior to installing a fix pack.
3. Choose a fix pack installation method and install the fix pack.
4. Perform the necessary tasks after installing the fix pack.
5. Apply the appropriate DB2 database product license.

If a previously licensed copy of a DB2 database server product does not already exist on the machine, a single server fix pack image can be used to install any of the DB2 database server products. In this case, the DB2 database product installed is treated as a try and buy license, and will stop working after a 90 day trial period unless you upgrade the try and buy license.

What to do next

Check the log file for any post-installation steps, or error messages and recommended actions.

For non-root installations on Linux or UNIX, root-based features (such as High Availability and operating system-based authentication) can be enabled using the `db2rfe` command. If root-based features were enabled after installing your DB2 database product, you must rerun the `db2rfe` command each time a fix pack is applied in order to re-enable those features.

If you have multiple DB2 copies on the same system, those copies can be at different version and fix pack levels. If you want to apply a fix pack to one or more DB2 copies, you must install the fix pack on those DB2 copies one by one.

Chapter 16. DB2 Connect product installation requirements for host and midrange systems

DB2 Connect products enable workstations to connect to databases on supported host and midrange platforms (for example, DB2 on z/OS). In some cases, DB2 Connect customers might need to apply patches to the host or midrange database product to enable this functionality.

See “Installing IBM data server clients (Linux and UNIX)” and “Installing IBM data server clients (Windows)” in *Installing IBM Data Server Clients*.

Part 7. Preparing communications and access to host and iSeries databases

Chapter 17. Preparing DB2 for IBM i for connections from DB2 Connect

DB2 Connect gives remote system applications access to data on your DB2 for IBM i system.

To set up the connection, you need to know the following:

1. The local network name. You can get this information by entering DSPNETA.
2. The local adapter address. You can get this information by entering the WRKLIND command in one of the following ways:

WRKLIND (*e1an)

Lists Ethernet adapters

WRKLIND (*tr1an)

Lists token ring adapters

WRKLIND (*a11)

Lists all adapters

3. The hostname. You can get this information by entering DSPNETA.
4. The TCP/IP port or service name. The default is X'07'6DB (X'07F6C4C2'). The default is always used by DB2 for i. If entering a hexadecimal number is not convenient, an alias is QCNTEDDM.
5. The relational database name. You can get this information by entering DSPRDBDIRE. This will display a list. The line containing *LOCAL in the Remote Location column identifies the RDBNAME which must be defined to the client. If there is no *LOCAL entry, you can add one, or use the system name obtained from the DSPNETA command on the server.

Here is an example:

```

Display Relational Database Directory Entries

Position to . . . . .
Type options, press Enter.
  5=Display details  6=Print details

Option          Relational          Remote
                Database          Location Text
-----
-              _____
-              DLHX              RCHAS2FA
-              JORMT2FA          JORMT2FA
-              JORMT4FD          JORMT4FD
-              JOSNAR7B          RCHASR7B
-              RCHASR7B          *LOCAL
-              RCHASR7C          RCHASR7C
-              R7BDH3SNA          RCH2PDH3
-              RCHASDH3          RCHASDH3

```

When you have obtained these parameters from your IBM Power Systems server, enter your values into the worksheet that follows:

Table 9. Configuration parameters from IBM Power Systems

Item	Parameter	Example	Your value
A-1	Local network name	SPIFNET	
A-2	Local adapter address	400009451902	
A-4	Hostname	SYD2101A	
A-5	TCP/IP port or service name	X'07F6C4C2' (default)	
A-6	Relational database name	NEW_YORK3	

For more information, refer to the “DRDA Considerations” section of the *DB2 Server for VSE & VM SQL Reference* (SC09-2989).

Chapter 18. Preparing DB2 for z/OS for connections from DB2 Connect

Before you begin

This topic provides instructions for establishing TCP/IP network connections between DB2 Connect and DB2 for z/OS.

If you anticipate that DB2 for z/OS will participate in a multisite update transaction (two-phase commit) then refer to “Enabling Multisite Updates using the Control Center” in *DB2 Connect User’s Guide*.

Procedure

To prepare DB2 for z/OS to receive connection requests from DB2 Connect, you need to configure your protocol by:

- “Configuring TCP/IP for DB2 for z/OS” on page 98
- “Configuring DB2 for z/OS” on page 100

Host databases

The term *database* is used throughout this document to describe a relational database management system (RDBMS). Other systems with which DB2 Connect communicates might use the term database to describe a slightly different concept. The DB2 Connect term database can also refer to:

System z

DB2 for z/OS. A DB2 for z/OS subsystem identified by its LOCATION NAME. The LOCATION NAME can be determined by logging into TSO and issuing the following SQL query using one of the available query tools:

```
select current server from sysibm.sysdummy1
```

LOCATION NAME is also defined in the Boot Strap Data Set (BSDS) as well as the DSNL004I message (LOCATION=location), which is written when the Distributed Data Facility (DDF) is started. LOCATION NAME supports up to 8 alias location names, allowing applications the ability to use different dbalias names to access a Version 8 z/OS server. Use the z/OS -display ddf command to get the DB2 server location name, domain name, IP address and port.

VSE DB2 for VSE running in a database partition identified by its DBNAME

VM DB2 for VM running in a CMS virtual machine identified by its DBNAME

IBM Power Systems Servers

DB2 for IBM i, an integral part of the IBM i operating system. Only one database can exist on an IBM Power Systems server unless the system is configured to use independent auxiliary storage pools.

Configuring TCP/IP for DB2 for z/OS

This topic describes how to configure TCP/IP communications between your DB2 Connect workstation and DB2 for z/OS Version 7 or later. The instructions assume the following conditions:

- You are connecting to a single host database via TCP/IP. Multiple host connections will be handled in exactly the same way, although the *port number* and *service number* required in each case might be different.
 - The target database resides on DB2 for z/OS Version 7 or later.
 - All the necessary software prerequisites are installed.
 - DB2 clients have been set up as required.
1. Before you can use DB2 Connect over a TCP/IP connection, you must collect information about both the host database server and the DB2 Connect server. For each host server that you are connecting to via TCP/IP, you must have the following information:

- The location of the TCP/IP services and hosts files at the DB2 Connect workstation:

On UNIX and Linux

/etc/

On Windows XP and Windows Server 2003

Usually %SystemRoot%\system32\drivers\etc\, where %SystemRoot% represents the Windows install path directory.

You might want to add the host information to a *domain name server* to avoid maintaining this file on multiple systems.

- The locations of the equivalent files at the target DB2 for z/OS host.
- The TCP/IP *port number* defined to DB2 for z/OS.

Note: The associated *service name* information is not exchanged between the DB2 Connect workstation and DB2 for z/OS.

Port number 446 has been registered as the default for communication from a DB2 Connect workstation.

- The TCP/IP addresses and host names for both the host and the DB2 Connect workstation.
 - The LOCATION NAME of the DB2 for z/OS database server.
 - The user ID and password to be used when issuing CONNECT requests to the database at the IBM mainframe server.
2. Refer to your local network administrator and your DB2 for z/OS administrator for help getting this information. Use the tables that follow as a worksheet to plan *each* TCP/IP connection between DB2 Connect and a host database server.

Table 10. User Information

Ref.	Description	Sample Value	Your Value
TCP-1	User name	A.D.B.User	
TCP-2	Contact info	(123)-456-7890	
TCP-5	User ID	ADBUSER	
TCP-6	Database type	db2390	

Table 10. User Information (continued)

Ref.	Description	Sample Value	Your Value
TCP-7	Connection type (must be TCPIP).	TCPIP	TCPIP

Table 11. Network Elements at the Host

Ref.	Description	Sample Value	Your Value
TCP-8	Host name	MVSHOST	
TCP-9	Host IP address	9.21.152.100	
TCP-10	Service name	db2inst1c	
TCP-11	Port number	446	446
TCP-12	LOCATION NAME	NEW_YORK3	
TCP-13	User ID		
TCP-14	Password		

Note:

- a. To obtain the host's IP address TCP-9, enter at the host:
TSO NETSTAT HOME
- b. To obtain the port number TCP-11, look for DSNL004I in the DB2 master address space or system log.

Table 12. Network Elements at the DB2 Connect Workstation

Ref.	Description	Sample Value	Your Value
TCP-18	Host name	mcook02	
TCP-19	IP address	9.21.27.179	
TCP-20	Service name	db2inst1c	
TCP-21	Port number	446	446

Table 13. DB2 Directory Entries at the DB2 Connect Workstation

Ref.	Description	Sample Value	Your Value
TCP-30	Node name	MVSIPNOD	
TCP-31	Database name	nyc3	
TCP-32	Database alias	mvsipdb1	
TCP-33	DCS database name	nyc3	

3. Complete a copy of the worksheet example for each TCP/IP host:
 - a. Fill in the values to be used for the host name and IP address of the DB2 for z/OS host (TCP-8 and TCP-9).
 - b. Fill in the values to be used for the host name and IP address of the DB2 Connect workstation (TCP-18 and TCP-19).
 - c. Determine the service name or port number to be used for the connection (TCP-10 or TCP-20, or TCP-11 or TCP-21).
 - d. Determine the LOCATION NAME of the DB2 for z/OS database server to which you want to connect.
 - e. Determine the values to be used for user ID and PASSWORD when connecting to the host database.

4. At your System z server:
 - a. Verify the host address or the host name.
 - b. Verify the port number or the service name.
 - c. Update the services file with the correct port number and service name if necessary.
 - d. Update the hosts file (or the Domain Name Server used by the DB2 for z/OS system) with the host name and IP address of the DB2 Connect workstation if necessary.
 - e. Ensure the new definitions are active before attempting to test the connection. Refer to your host network administrator or change control staff if necessary.
 - f. Check with the DB2 for z/OS administrator that you have a valid user ID, password, and database *LOCATION NAME*.
 - g. PING the DB2 Connect server, using the correct port number if that option is supported by TCP/IP on the host system. For example:

```
ping remote_host_name -p port_number
```

Note: DB2 Connect does not support the PING command when issued from a Version 7 client through a Version 9 gateway to the host.

Support for your System z server is available at <http://www.ibm.com/servers/eserver/support/zseries/>

Configuring DB2 for z/OS

Before you can use DB2 Connect, your DB2 for z/OS Administrator must configure DB2 for z/OS to permit connections from DB2 Connect workstations. This section indicates the *minimum* updates required to permit a DB2 Connect client to make a connection to the DB2 for z/OS database server. For more detailed examples, refer to the DB2 for z/OS installation documentation:

- Version 7 documentation is available at <http://www.ibm.com/software/data/db2/zos/v7books.html>
- Version 8 documentation is available at <http://www.ibm.com/software/data/db2/zos/v8books.html>
- Version 9 documentation is available at <http://www.ibm.com/software/data/db2/zos/v9books.html>

Recommended maintenance level

For DB2 for z/OS Version 7, apply the fixes for APARs PQ50016, PQ50017 and PK05198.

See also <http://www.ibm.com/servers/eserver/zseries/zos/servicetst/> for the latest Consolidated Service Test.

Chapter 19. Preparing DB2 for VSE & VM for connections from DB2 Connect

For information about how to set up DB2 Server for VM and VSE as an application server, refer to the “DRDA Considerations” section of the *DB2 Server for VSE & VM SQL Reference* (SC09-2989) .

Chapter 20. Configuring connections to mainframe and midrange servers

After DB2 Connect is installed and the database server is configured to accept communications, you need to establish and fine-tune the connection between the two systems. The connections to the remote systems is done using either the Configuration Assistant (CA) or the command line processor (CLP).

Configuring a connection to IBM mainframe database servers using the CA (Linux and Windows)

This task describes how to connect to IBM mainframe database server from your DB2 Connect workstation using the Configuration Assistant (CA). The CA is a DB2 GUI tool that can be used to configure database connections and other database settings.

Before you begin

Note: In previous releases, the DB2 Administration Tools, such as the CA, were supported on all platforms. As of Version 9, the DB2 Administration Tools are supported only on Windows x86, Windows x64 (AMD64/EM64T), Linux on x86, and Linux on AMD64/EM64T. For all platforms, you can use the DB2 command line processor (CLP) to configure a connection to an IBM mainframe database server.

- The Configuration Assistant must be installed on your DB2 Connect workstation. The Configuration Assistant is available as part of the IBM data server client.
- The remote server must be configured to accept inbound client requests. By default, the server installation program detects and configures most protocols on the server for inbound client connections.

About this task

Your DB2 Connect workstation can be either:

A IBM data server client

The IBM data server client can connect indirectly to IBM mainframe databases through a DB2 Connect server product.

DB2 Connect Personal Edition

You can connect directly to IBM mainframe databases using DB2 Connect Personal Edition. You can also connect through a DB2 Connect server product.

Procedure

The following methods can be used to configure a connection to a database using the CA:

- Connecting to a database using a client profile.
See "Configuring database connections using a client profile with the Configuration Assistant" in *Installing IBM Data Server Clients*.
- Connecting to a database manually using the CA.

See “Configuring database connections using a client profile with the Configuration Assistant” in *Installing IBM Data Server Clients*.

Configuring a connection to IBM mainframe database servers using the CLP

You can manually configure your TCP/IP connection between a DB2 Connect server and a IBM mainframe database using the DB2 command line processor (CLP).

Prerequisites

Before you manually configure a TCP/IP connection between DB2 Connect and a IBM mainframe database server, ensure that:

- TCP/IP is functional on the DB2 Connect server and IBM mainframe system.
- You have identified the following parameter values:
 - Hostname (*hostname*) or IP address (*ip_address*)
 - Connection Service name (*svcename*) or Port number/Protocol (*port_number/tcp*)
 - Target database name (*target_dbname*)
 - Local database name (*local_dcsname*)
 - Node name (*node_name*)

To manually configure TCP/IP communications between your DB2 Connect server and an IBM mainframe database:

1. Configure TCP/IP on the DB2 Connect server.
2. Refer to the “CATALOG TCPIP/TCPIP4/TCPIP6 NODE command” topic in the *Command Reference*.
3. Refer to the “CATALOG DCS DATABASE command” topic in the *Command Reference*.
4. Refer to the “CATALOG DATABASE command” topic in the *Command Reference*.
5. Bind utilities and applications to the IBM mainframe database server.
6. Refer to the “CONNECT (Type 1) statement” topic in the *SQL Reference, Volume 2* to test the IBM mainframe connection.

Note: Due to the characteristics of the TCP/IP protocol, TCP/IP might not be immediately notified of a partner’s failure on another IBM mainframe. As a result, a client application accessing a remote DB2 server using TCP/IP, or the corresponding agent at the server, might sometimes appear to be hung. The TCP/IP SO_KEEPALIVE socket option is used to detect when there has been a failure and the TCP/IP connection has been broken.

Part 8. Reference

Chapter 21. Configuring access to IBM mainframe databases

After DB2 Connect is installed and the database server is configured to accept communications, you need to establish and fine-tune the connection between the two systems. This section describes how to use the Configuration Assistant (CA) or the DB2 command line processor (CLP) to find, connect, and bind to a database server.

Configuring a database connection by searching the network using the Configuration Assistant

You can use the Configuration Assistant (CA) to search a network for databases.

Before you configure a database connection by searching the network:

- Ensure that you have a valid DB2 user ID.
- If you are configuring a connection from a system that has a DB2 Server or DB2 Connect server product installed, ensure that you have a user ID with SYSADM or SYSCTRL authority for the instance.

The search method feature might be unable to detect a remote system if:

- It is used in a cluster environment.
- The DB2 Administration Server (DAS) is not running on the remote system.
- The search times out. By default, the search will scan the network for 1 second; this might not be long enough to detect the remote system. You can set the DB2DISCOVERYTIME registry variable to specify a longer period of time.
- The network that the search is running on is configured so that the search does not reach the remote system required.

The following points apply to cases where you want to explicitly configure an IPv6 address on a network that supports IPv6:

- The system must be listed under **Known Systems**.
- Only the Configuration Assistant Advanced View supports explicitly configure an IPv6 connection.

To configure a database connection by searching the network:

1. Log on to the system with a valid DB2 user ID.
2. Start the CA. The CA can be started from the Start menu on Windows or using the db2ca command on both Windows and UNIX systems.
3. On the CA menu bar, under **Selected**, choose **Add Database Using Wizard**. The **Add Database Wizard** opens.
4. Select the **Search the network** radio button and click **Next**.
5. Double-click the folder beside **Known Systems** to list all the systems known to your client or double-click the folder beside **Other Systems** to list all the systems on the network. If no systems are listed, you can click **Add System** to specify one. After you add a system, it displays in the **Known Systems** list.
6. Expand the entries for the system you are interested in until you see the database you want to add. Select the database. Click **Next**.
7. Type a local database alias name in the **Database alias** field and optionally type a comment that describes this database in the **Comment** field.

8. If you are planning to use ODBC, register this database as an ODBC data source. ODBC must be installed to perform this operation.
9. Click **Finish**. You can now use the database you added. Click **Close** to exit the CA.

Configuring a database connection manually using the Configuration Assistant

If you have the information for the database you want to connect to and the server upon which it resides, you can manually enter all of the configuration information. This method is analogous to entering commands using the command line processor, however, the parameters are presented graphically.

Before you configure a connection to a database manually using the Configuration Assistant (CA):

- Ensure that you have a valid DB2 user ID for the database you want to connect to.
- If you are configuring a connection from a system that has a DB2 server or DB2 Connect server product installed, ensure that you have a user ID with SYSADM or SYSCTRL authority for the database manager instance.

To configure a connection to a database manually using the CA:

1. Log on to the system with a valid DB2 user ID.
2. Start the CA. The CA can be started from the Start menu on Windows or using the db2ca command.
3. On the CA menu bar, under **Selected**, choose **Add Database Using Wizard**.
4. Select the **Manually configure a connection to a database** radio button and click **Next**.
5. If you are using Lightweight Directory Access Protocol (LDAP), select the radio button that corresponds to the location where you want DB2 directories to be maintained. Click **Next**.
6. Select the radio button that corresponds to the protocol that you want to use from the **Protocol** list. (Note: While APPC, APPN, or NetBIOS might still display as options, they are no longer supported.) If DB2 Connect is installed on your system and you select TCP/IP, you have the option to select **The database physically resides on a host or OS/400 system**. If you select this check box, you have the option of selecting the type of connection that you want to make to the host or OS/400® database:
 - To make a connection through a DB2 Connect gateway, select the **Connect to the server via the gateway** radio button.
 - To make a direct connection, select the **Connect directly to the server** radio button.Click **Next**.
7. Type the required communication protocol parameters and click **Next**.
8. Type the database alias name of the remote database that you want to add in the **Database name** field and a local database alias name in the **Database alias** field. If you are adding a host or OS/400 database, type the location name for an OS/390 or z/OS database, the RDB name for an OS/400 database, or the DBNAME for a VSE or VM database in the **Database name** field. Optionally, you can add a comment that describes this database in the **Comment**. Click **Next**.

9. If you are planning to use ODBC, register this database as an ODBC data source. Ensure that ODBC is installed before performing this operation. Click **Next**.
10. In the **Specify the node options** window, select the operating system, and type the remote instance name for the database system you want to connect to.
11. In the **Specify the system options** window, ensure that system name, host name, and operating system are correct. The information on this panel is used to configure the administration node. You can optionally enter a comment. Click **Next**.
12. In the **Specify the security options** window, specify the security option that will be used for authentication.
13. Click **Finish**. You can now use this database. Select the **Exit** menu action to close the CA.

Testing a database connection using the Configuration Assistant

After configuration, test your database connection.

To test a database connection:

1. Start the **Configuration Assistant**.
2. Highlight the database in the details view and select **Test Connection** from the **Selected** menu. The Test Connection window opens.
3. Select one or more types of connection that you want to test (**CLI** is the default). You can test more than one type at the same time. Enter a valid user ID and password for the remote database and click **Test Connection**. If the connection is successful, a message confirming the connection appears on the Results page. If the connection test failed, you will receive a help message. To change any settings you might have incorrectly specified, select the database in the details view and select **Change Database** from the **Selected** menu item.

When setting up a server to work with development environments (such as IBM Data Studio), you might encounter error message SQL30081N at the initial DB2 connection. A possible root cause is that the firewall at the remote database server has prevented the connection from being established. In this case, verify the firewall is properly configured to accept connection requests from the client.

Removing a DCS (host database)

Use the DCS page of the Advanced Configuration Assistant notebook to remove a DCS (host database) entry.

1. If you are not in the Advanced view, from the **View** menu, select **Advanced View**.
2. Select the DCS entry that you want to remove.
3. From the **Selected** menu, click **Remove DCS**. A confirmation window opens where you verify your selection.

Chapter 22. Supported DB2 interface languages

DB2 language support for DB2 interfaces can be categorized into server group languages and client group languages. Server group languages will translate most messages, help, and DB2 graphical interface elements. Client group languages will translate the IBM Data Server Runtime Client component, which will include most messages and certain help documentation.

Server group languages include: Brazilian Portuguese, Czech, Danish, Finnish, French, German, Italian, Japanese, Korean, Norwegian, Polish, Russian, Simplified Chinese, Spanish, Swedish, and Traditional Chinese.

Client group languages include: Arabic, Bulgarian, Croatian, Dutch, Greek, Hebrew, Hungarian, Portuguese, Romanian, Slovak, Slovenian, and Turkish.

Do not confuse languages supported by the DB2 product with languages supported by the DB2 interface. Languages supported by the DB2 product means the languages in which data can exist. These languages are a superset of languages supported by the DB2 interface.

Displaying the DB2 Setup wizard in your national language (Linux and UNIX)

The `db2setup` command queries the operating system to determine the existing language settings. If the language setting of your operating system is supported by `db2setup`, then that language will be used when displaying the DB2 Setup wizard.

If your system uses the same code pages but different locale names than those supported by the DB2 interface, you can still see the translated `db2setup` by setting your `LANG` environment variable to the appropriate value by entering the following command:

bourne (sh), korn (ksh), and bash shells:

```
LANG=<locale>  
export LANG
```

C shell:

```
setenv LANG <locale>
```

where *locale* is a locale supported by the DB2 interface.

Language identifiers for running the DB2 Setup wizard in another language

If you want to run the DB2 Setup wizard in a language different from the default language on your computer, you can start the DB2 Setup wizard manually, specifying a language identifier. The language must be available on the platform where you are running the installation.

On Windows operating systems, you can run `setup.exe` with the `-i` parameter to specify the two-letter language code of the language the installation is to use.

On Linux and UNIX operating systems, it is recommended that you set the **LANG** environment variable to display the DB2 Setup wizard in your national language.

Table 14. Language identifiers

Language	Language identifier
Arabic (available on Windows platforms only)	ar
Brazilian Portuguese	br
Bulgarian	bg
Chinese, Simplified	cn
Chinese, Traditional	tw
Croatian	hr
Czech	cz
Danish	dk
Dutch	nl
English	en
Finnish	fi
French	fr
German	de
Greek	el
Hungarian	hu
Italian	it
Japanese	jp
Korean	kr
Norwegian	no
Polish	pl
Portuguese	pt
Romanian	ro
Russian	ru
Slovak	sk
Slovenian	sl
Spanish	es
Swedish	se
Turkish	tr

Changing the DB2 product interface language (Windows)

The DB2 interface language is the language that appears in messages, help, and graphical tool interfaces. When installing your DB2 product, you have the option of installing support for one or more languages. After installation, you can change the DB2 interface language to one of the other installed interface languages.

Do not confuse languages supported by a DB2 product with languages supported by the DB2 interface. Languages supported by a DB2 product means the languages in which data can exist. These languages are a superset of languages supported by the DB2 interface.

The DB2 interface language you want to use must be installed on your system. The DB2 product interface languages are selected and installed when you install a DB2 product using the DB2 Setup wizard. If you change the interface language of a DB2 product to a supported interface language that has not been installed, the DB2 product interface language will default to the operating system language first, and if that is not supported, English.

Changing the interface language for a DB2 product on Windows requires that you change the default language setting for your Windows operating system.

To change the DB2 product interface language on Windows operating systems:

1. Through the Control Panel, select **Regional and Language Options**.
2. On the **Regional Options** tab under **Standards and formats**, select the appropriate language. On Windows 2008 and Windows Vista or higher, use the **Formats** tab for this step.
3. On the **Regional Options** tab under **Location**, select the location that corresponds to the appropriate language.
4. On the **Advanced** tab under **Language for non-Unicode programs** select the appropriate language. On Windows 2008 and Windows Vista or higher, on the **Administrative** tab, under **Language for non-unicode programs**, click **Change system locale** and select the appropriate language. You will then be asked to reboot, click **Cancel**.
5. On the **Advanced** tab under **Default user account settings**, check the **Apply all settings to the current user account and to the default user profile** box. On Windows 2008 and Windows Vista or higher, on the **Administrative** tab under **reserved accounts**, click **Copy to reserved accounts** and check the accounts that you want to copy the language settings to.
6. You will be asked to reboot before these changes come into effect.

Refer to your operating system help for additional information about changing the default system language.

Changing the DB2 interface language (Linux and UNIX)

The interface language of the DB2 product is the language that appears in messages, help, and graphical tool interfaces. When installing your DB2 product, you have the option of installing support for one or more languages. If, at some time after installation, you want to change the interface language to one of the other installed interface languages, use the steps outlined in this task.

Do not confuse languages supported by the DB2 product with languages supported by the DB2 interface. Languages supported by the DB2 product, that is, languages that *data* can exist in, are a superset of languages supported by the DB2 interface.

Support for the DB2 interface language you want to use must be installed on your system. DB2 interface language support is selected and installed when you install DB2 using the DB2 Setup wizard. If you change the interface language of the DB2 product to a supported interface language that has not been installed, the DB2 interface language will default to the operating system language. If the operating system language is not supported, English is used as the DB2 interface language.

DB2 interface language support is selected and installed when you install your DB2 product using the DB2 Setup wizard or by using the National Language Package.

To check which public locales are available in your system, run the `$ locale -a` command.

To change the DB2 interface language, set the LANG environment variable to the locale you want.

For bourne (sh), korn (ksh), and bash shells:

```
LANG=<locale>  
export LANG
```

For C shell:

```
setenv LANG <locale>
```

For example, to interface with the DB2 product in French, you must have the French language support installed and you must set the LANG environment variable to a French locale, for example, `fr_FR`.

Conversion of character data

When character data is transferred between machines, it must be converted to a form that the receiving machine can use.

For example, when data is transferred between a DB2 Connect server and a host or System i database server, it is usually converted from a server code page to a host CCSID, and vice versa. If the two machines use different code pages or CCSIDs, code points are mapped from one code page or CCSID to the other. This conversion is always performed at the receiver.

Character data sent *to* a database consists of SQL statements and input data. Character data sent *from* a database consists of output data. Output data that is interpreted as bit data is not converted. For example, data from a column declared with the FOR BIT DATA clause. Otherwise, all input and output character data is converted if the two machines have different code pages or CCSIDs.

For example, if DB2 Connect is used to access data, the following happens:

1. DB2 Connect sends an SQL statement and input data to System z.
2. DB2 for z/OS converts the SQL statement and data to the host server's code page and then processes the data.
3. DB2 for z/OS sends the result back to the DB2 Connect server.
4. DB2 Connect converts the result to the code page of the user's environment.

For bidirectional languages, a number of special "BiDi CCSIDS" have been defined by IBM and are supported by DB2 Connect.

If the bidirectional attributes of the database server are different from those of the client you can use these special CCSIDS to manage the difference.

Refer to the supported territory codes and code pages topic for the supported conversions between code pages on the DB2 Connect and CCSIDs on the host or System i server.

Chapter 23. Developing database applications

Binding and running your applications in an environment that uses DB2 Connect has specific considerations which are presented here.

Binding database utilities on DB2 Connect

You must bind the database utilities (import, export, reorg, the Command Line Processor) and DB2 CLI bind files to each database before they can be used with that database. In a network environment, if you are using multiple clients that run on different operating systems or are at different versions or service levels of DB2, you must bind the utilities once for each operating system and DB2-version combination.

Binding a utility creates a *package*, which is an object that includes all of the information that is needed to process specific SQL statements from a single source file.

The bind files are grouped together in different *.lst* files in the *bnd* directory, under the installation directory (typically *sql11ib* for Windows). Each file is specific to a server.

- To bind the utilities and applications to the IBM mainframe database server, connect to the IBM mainframe server and use the following example as a template:

```
connect to dbalias user userid using password
bind path/bnd/@ddcsmvs.lst blocking all sqlerror continue
      messages mvs.msg grant public
connect reset
```

where *path* corresponds to the *DB2PATH* registry value.

- To bind database utilities to a DB2 database, use one of the following methods, depending on your workstation's operating system:
 - The Configuration Assistant (CA):
 1. Start the CA.
 2. Select the database to which you want to bind the utilities.
 3. Right click and select **Bind**.
 4. Select the utility or files to bind.
 5. Add any desired bind options.
 6. Enter a user ID and password to connect to the database. The user ID must have the authority to bind new packages against the database. Click **Bind**.
 - The command line processor:
 1. Change to the *bnd* directory, which is *x:\sql11ib\bnd*, where *x*: represents the drive where you installed DB2.
 2. To connect to the database, enter the following commands in the Command Center or the Command Line Processor:

```
connect to database_alias
```

where *database_alias* represents the alias of the database to which you want to connect.

3. Enter the following commands in the Command Center or the Command Line Processor:

```
"bind @db2ubind.lst messages bind.msg grant public"  
"bind @db2cli.lst messages clibind.msg grant public"
```

In this example, `bind.msg` and `clibind.msg` are the output message files, and EXECUTE and BINDADD privileges are granted to *public*.

4. Reset the connection to the database by entering the following command:
`connect reset`

Note:

1. The `db2ubind.lst` file contains the list of bind (.bnd) files required to create the packages for the database utilities. The `db2cli.lst` file contains the list of bind (.bnd) files required to create packages for the DB2 CLI and the DB2 ODBC driver.
2. Binding might take a few minutes to complete.
3. If you have BINDADD authority, the first time you use the DB2 CLI or ODBC driver, the DB2 CLI packages will be bound automatically. If the applications that you are using require binding to the database, you can use the Configuration Assistant's Bind facility, or the command line processor, to perform the bind action.

Running your own applications

You can build and run DB2 applications with an IBM Data Server Client installed.

Various types of applications can access DB2 databases:

- Applications developed using the IBM data server client that include embedded SQL, APIs, stored procedures, user-defined functions or calls to the DB2 CLI
- ODBC applications
- Java applications using the JDBC or SQLJ interfaces
- PHP applications
- Ruby or Ruby on Rails applications
- Perl applications
- Python applications

On Windows operating systems, the following can also access DB2 databases:

- ActiveX Data Objects (ADO) implemented in Microsoft Visual Basic and Microsoft Visual C++
- Object Linking and Embedding (OLE) Automation Routines (UDFs and Stored Procedures)
- Object Linking and Embedding Database (OLE DB) table functions

To run an application:

1. Ensure the server is configured and running.
2. On the DB2 server, ensure that the database manager is started on the database server to which the application program is connecting. If it is not, you must issue the **db2start** command at the server before starting the application.
3. Ensure that you can connect to the database that the application uses.
4. (Optionally) Bind the necessary files to support the database application driver being used.

5. Run the application program.

Chapter 24. Uninstalling DB2 Connect

At some point in the future you may need to remove your DB2 Connect products from your system. The requirements for removing or uninstalling your DB2 Connect products are presented based on the operating system you are using.

Uninstalling your DB2 product (Windows)

This task provides steps for completely removing your DB2 product from your Windows operating system. Only perform this task if you no longer require your existing DB2 instances and databases.

If you are uninstalling the default DB2 copy, and you have other DB2 copies on your system, use the `db2swtch` command to choose a new default copy before you proceed with the uninstallation. Also, if your DB2 Administration Server (DAS) is running under the copy being removed, move your DAS to a copy that is not being removed. Otherwise, re-create the DAS using the `db2admin create` command after the uninstall, and you reconfigure the DAS for some function to work.

To remove your DB2 product from Windows:

1. (Optional) Drop all databases using the Control Center or drop database command. Be sure that you no longer need these databases. If you drop your databases, all of your data will be gone.
2. Stop all DB2 processes and services. This can be done through the Windows Services panel or by issuing the `db2stop` command. If DB2 services and processes are not stopped before attempting to remove your DB2 product, you will receive a warning containing a list of processes and services that are holding DB2 DLLs in memory. If you will use Add/Remove Programs to remove your DB2 product, this step is optional.
3. You have two options for removing your DB2 product:

Add/Remove Programs

Accessible through the Windows Control Panel, use the Add/Remove Programs window to remove your DB2 product. Refer to your operating system's help for more information about removing software products from your Windows operating system.

db2unins command

You can run the `db2unins` command from the `DB2DIR\bin` directory to remove your DB2 products, features, or languages. Using this command, you can uninstall multiple DB2 products at the same time using the `/p` parameter. You can use a response file to uninstall DB2 products, features, or languages using `/u` parameter. For more information, see the `db2unins` command topic.

Unfortunately, your DB2 product cannot always be removed by using the Control Panel - Add/Remove Programs facility or using the `db2unins /p` command or the `db2unins /u` command. The following uninstallation option must ONLY be attempted if the previous method fails.

To forcefully remove all DB2 copies from your Windows system, run the `db2unins /f` command. This command will perform a brute force uninstallation of ALL DB2

copies on the system. Everything except user data, such as DB2 databases, will be forcefully deleted. Before running this command with the /f parameter, see the db2unins command for details.

Uninstalling your DB2 product (Linux and UNIX)

This task provides steps for removing a DB2 product from your Linux or UNIX operating system.

This task is not required to install a new version of a DB2 product. Each version of a DB2 product on Linux or UNIX has a different installation path and can therefore coexist on the same computer.

Note: This task applies to DB2 products that were installed with root authority. A separate topic explains how to uninstall DB2 products that were installed as a non-root user.

To remove your DB2 product:

1. Optional: Drop all databases. You can drop databases using the Control Center or the drop database command. Database files remain intact on your file systems when you drop an instance without dropping databases first.
2. Stop the DB2 Administration Server. Refer to the *Installing DB2 Servers* manual.
3. Remove the DB2 Administration Server, or run the dasupdt command to update the DB2 Administration Server to another installation path. To remove the DB2 Administration Server, refer to the *Installing DB2 Servers* manual.
4. Stop all DB2 instances. Refer to the *Installing DB2 Servers* manual.
5. Remove the DB2 instances, or run the db2iupdt command to update the instances another installation path. To remove the DB2 instances, refer to the *Installing DB2 Servers* manual.
6. Remove the DB2 products. Refer to the *Installing DB2 Servers* manual.

Part 9. Appendixes

Appendix A. Overview of the DB2 technical information

DB2 technical information is available through the following tools and methods:

- DB2 Information Center
 - Topics (Task, concept and reference topics)
 - Help for DB2 tools
 - Sample programs
 - Tutorials
- DB2 books
 - PDF files (downloadable)
 - PDF files (from the DB2 PDF DVD)
 - printed books
- Command line help
 - Command help
 - Message help

Note: The DB2 Information Center topics are updated more frequently than either the PDF or the hardcopy books. To get the most current information, install the documentation updates as they become available, or refer to the DB2 Information Center at ibm.com.

You can access additional DB2 technical information such as technotes, white papers, and IBM Redbooks® publications online at ibm.com. Access the DB2 Information Management software library site at <http://www.ibm.com/software/data/sw-library/>.

Documentation feedback

We value your feedback on the DB2 documentation. If you have suggestions for how to improve the DB2 documentation, send an e-mail to db2docs@ca.ibm.com. The DB2 documentation team reads all of your feedback, but cannot respond to you directly. Provide specific examples wherever possible so that we can better understand your concerns. If you are providing feedback on a specific topic or help file, include the topic title and URL.

Do not use this e-mail address to contact DB2 Customer Support. If you have a DB2 technical issue that the documentation does not resolve, contact your local IBM service center for assistance.

DB2 technical library in hardcopy or PDF format

The following tables describe the DB2 library available from the IBM Publications Center at www.ibm.com/shop/publications/order. English and translated DB2 Version 9.7 manuals in PDF format can be downloaded from www.ibm.com/support/docview.wss?rs=71&uid=swg2700947.

Although the tables identify books available in print, the books might not be available in your country or region.

The form number increases each time a manual is updated. Ensure that you are reading the most recent version of the manuals, as listed below.

Note: The *DB2 Information Center* is updated more frequently than either the PDF or the hard-copy books.

Table 15. DB2 technical information

Name	Form Number	Available in print	Last updated
<i>Administrative API Reference</i>	SC27-2435-01	Yes	November, 2009
<i>Administrative Routines and Views</i>	SC27-2436-01	No	November, 2009
<i>Call Level Interface Guide and Reference, Volume 1</i>	SC27-2437-01	Yes	November, 2009
<i>Call Level Interface Guide and Reference, Volume 2</i>	SC27-2438-01	Yes	November, 2009
<i>Command Reference</i>	SC27-2439-01	Yes	November, 2009
<i>Data Movement Utilities Guide and Reference</i>	SC27-2440-00	Yes	August, 2009
<i>Data Recovery and High Availability Guide and Reference</i>	SC27-2441-01	Yes	November, 2009
<i>Database Administration Concepts and Configuration Reference</i>	SC27-2442-01	Yes	November, 2009
<i>Database Monitoring Guide and Reference</i>	SC27-2458-00	Yes	August, 2009
<i>Database Security Guide</i>	SC27-2443-01	Yes	November, 2009
<i>DB2 Text Search Guide</i>	SC27-2459-01	Yes	November, 2009
<i>Developing ADO.NET and OLE DB Applications</i>	SC27-2444-00	Yes	August, 2009
<i>Developing Embedded SQL Applications</i>	SC27-2445-01	Yes	November, 2009
<i>Developing Java Applications</i>	SC27-2446-01	Yes	November, 2009
<i>Developing Perl, PHP, Python, and Ruby on Rails Applications</i>	SC27-2447-00	No	August, 2009
<i>Developing User-defined Routines (SQL and External)</i>	SC27-2448-01	Yes	November, 2009
<i>Getting Started with Database Application Development</i>	GI11-9410-01	Yes	November, 2009
<i>Getting Started with DB2 Installation and Administration on Linux and Windows</i>	GI11-9411-00	Yes	August, 2009

Table 15. DB2 technical information (continued)

Name	Form Number	Available in print	Last updated
<i>Globalization Guide</i>	SC27-2449-00	Yes	August, 2009
<i>Installing DB2 Servers</i>	GC27-2455-01	Yes	November, 2009
<i>Installing IBM Data Server Clients</i>	GC27-2454-00	No	August, 2009
<i>Message Reference Volume 1</i>	SC27-2450-01	No	November, 2009
<i>Message Reference Volume 2</i>	SC27-2451-01	No	November, 2009
<i>Net Search Extender Administration and User's Guide</i>	SC27-2469-01	No	November, 2009
<i>Partitioning and Clustering Guide</i>	SC27-2453-01	Yes	November, 2009
<i>pureXML Guide</i>	SC27-2465-01	Yes	November, 2009
<i>Query Patroller Administration and User's Guide</i>	SC27-2467-00	No	August, 2009
<i>Spatial Extender and Geodetic Data Management Feature User's Guide and Reference</i>	SC27-2468-00	No	August, 2009
<i>SQL Procedural Languages: Application Enablement and Support</i>	SC27-2470-00	Yes	August, 2009
<i>SQL Reference, Volume 1</i>	SC27-2456-01	Yes	November, 2009
<i>SQL Reference, Volume 2</i>	SC27-2457-01	Yes	November, 2009
<i>Troubleshooting and Tuning Database Performance</i>	SC27-2461-01	Yes	November, 2009
<i>Upgrading to DB2 Version 9.7</i>	SC27-2452-01	Yes	November, 2009
<i>Visual Explain Tutorial</i>	SC27-2462-00	No	August, 2009
<i>What's New for DB2 Version 9.7</i>	SC27-2463-01	Yes	November, 2009
<i>Workload Manager Guide and Reference</i>	SC27-2464-00	Yes	August, 2009
<i>XQuery Reference</i>	SC27-2466-01	No	November, 2009

Table 16. DB2 Connect-specific technical information

Name	Form Number	Available in print	Last updated
<i>Installing and Configuring DB2 Connect Personal Edition</i>	SC27-2432-01	Yes	November, 2009
<i>Installing and Configuring DB2 Connect Servers</i>	SC27-2433-01	Yes	November, 2009

Table 16. DB2 Connect-specific technical information (continued)

Name	Form Number	Available in print	Last updated
DB2 Connect User's Guide	SC27-2434-01	Yes	November, 2009

Table 17. Information Integration technical information

Name	Form Number	Available in print	Last updated
Information Integration: Administration Guide for Federated Systems	SC19-1020-02	Yes	August, 2009
Information Integration: ASNCLP Program Reference for Replication and Event Publishing	SC19-1018-04	Yes	August, 2009
Information Integration: Configuration Guide for Federated Data Sources	SC19-1034-02	No	August, 2009
Information Integration: SQL Replication Guide and Reference	SC19-1030-02	Yes	August, 2009
Information Integration: Introduction to Replication and Event Publishing	GC19-1028-02	Yes	August, 2009

Ordering printed DB2 books

If you require printed DB2 books, you can buy them online in many but not all countries or regions. You can always order printed DB2 books from your local IBM representative. Keep in mind that some softcopy books on the *DB2 PDF Documentation DVD* are unavailable in print. For example, neither volume of the *DB2 Message Reference* is available as a printed book.

Printed versions of many of the DB2 books available on the *DB2 PDF Documentation DVD* can be ordered for a fee from IBM. Depending on where you are placing your order from, you may be able to order books online, from the IBM Publications Center. If online ordering is not available in your country or region, you can always order printed DB2 books from your local IBM representative. Note that not all books on the *DB2 PDF Documentation DVD* are available in print.

Note: The most up-to-date and complete DB2 documentation is maintained in the DB2 Information Center at <http://publib.boulder.ibm.com/infocenter/db2luw/v9r7>.

To order printed DB2 books:

- To find out whether you can order printed DB2 books online in your country or region, check the IBM Publications Center at <http://www.ibm.com/shop/publications/order>. You must select a country, region, or language to access publication ordering information and then follow the ordering instructions for your location.
- To order printed DB2 books from your local IBM representative:

1. Locate the contact information for your local representative from one of the following Web sites:
 - The IBM directory of world wide contacts at www.ibm.com/planetwide
 - The IBM Publications Web site at <http://www.ibm.com/shop/publications/order>. You will need to select your country, region, or language to the access appropriate publications home page for your location. From this page, follow the "About this site" link.
2. When you call, specify that you want to order a DB2 publication.
3. Provide your representative with the titles and form numbers of the books that you want to order. For titles and form numbers, see "DB2 technical library in hardcopy or PDF format" on page 123.

Displaying SQL state help from the command line processor

DB2 products return an SQLSTATE value for conditions that can be the result of an SQL statement. SQLSTATE help explains the meanings of SQL states and SQL state class codes.

To start SQL state help, open the command line processor and enter:

```
? sqlstate or ? class code
```

where *sqlstate* represents a valid five-digit SQL state and *class code* represents the first two digits of the SQL state.

For example, ? 08003 displays help for the 08003 SQL state, and ? 08 displays help for the 08 class code.

Accessing different versions of the DB2 Information Center

For DB2 Version 9.7 topics, the *DB2 Information Center* URL is <http://publib.boulder.ibm.com/infocenter/db2luw/v9r7/>.

For DB2 Version 9.5 topics, the *DB2 Information Center* URL is <http://publib.boulder.ibm.com/infocenter/db2luw/v9r5/>.

For DB2 Version 9.1 topics, the *DB2 Information Center* URL is <http://publib.boulder.ibm.com/infocenter/db2luw/v9/>.

For DB2 Version 8 topics, go to the *DB2 Information Center* URL at: <http://publib.boulder.ibm.com/infocenter/db2luw/v8/>.

Displaying topics in your preferred language in the DB2 Information Center

The DB2 Information Center attempts to display topics in the language specified in your browser preferences. If a topic has not been translated into your preferred language, the DB2 Information Center displays the topic in English.

- To display topics in your preferred language in the Internet Explorer browser:
 1. In Internet Explorer, click the **Tools** —> **Internet Options** —> **Languages...** button. The Language Preferences window opens.
 2. Ensure your preferred language is specified as the first entry in the list of languages.
 - To add a new language to the list, click the **Add...** button.

Note: Adding a language does not guarantee that the computer has the fonts required to display the topics in the preferred language.

- To move a language to the top of the list, select the language and click the **Move Up** button until the language is first in the list of languages.
- 3. Refresh the page to display the DB2 Information Center in your preferred language.
- To display topics in your preferred language in a Firefox or Mozilla browser:
 1. Select the button in the **Languages** section of the **Tools** —> **Options** —> **Advanced** dialog. The Languages panel is displayed in the Preferences window.
 2. Ensure your preferred language is specified as the first entry in the list of languages.
 - To add a new language to the list, click the **Add...** button to select a language from the Add Languages window.
 - To move a language to the top of the list, select the language and click the **Move Up** button until the language is first in the list of languages.
 3. Refresh the page to display the DB2 Information Center in your preferred language.

On some browser and operating system combinations, you must also change the regional settings of your operating system to the locale and language of your choice.

Updating the DB2 Information Center installed on your computer or intranet server

A locally installed DB2 Information Center must be updated periodically.

Before you begin

A DB2 Version 9.7 Information Center must already be installed. For details, see the “Installing the DB2 Information Center using the DB2 Setup wizard” topic in *Installing DB2 Servers*. All prerequisites and restrictions that applied to installing the Information Center also apply to updating the Information Center.

About this task

An existing DB2 Information Center can be updated automatically or manually:

- Automatic updates - updates existing Information Center features and languages. An additional benefit of automatic updates is that the Information Center is unavailable for a minimal period of time during the update. In addition, automatic updates can be set to run as part of other batch jobs that run periodically.
- Manual updates - should be used when you want to add features or languages during the update process. For example, a local Information Center was originally installed with both English and French languages, and now you want to also install the German language; a manual update will install German, as well as, update the existing Information Center features and languages. However, a manual update requires you to manually stop, update, and restart the Information Center. The Information Center is unavailable during the entire update process.

Procedure

This topic details the process for automatic updates. For manual update instructions, see the “Manually updating the DB2 Information Center installed on your computer or intranet server” topic.

To automatically update the DB2 Information Center installed on your computer or intranet server:

1. On Linux operating systems,
 - a. Navigate to the path where the Information Center is installed. By default, the DB2 Information Center is installed in the `/opt/ibm/db2ic/V9.7` directory.
 - b. Navigate from the installation directory to the `doc/bin` directory.
 - c. Run the `ic-update` script:

```
ic-update
```
2. On Windows operating systems,
 - a. Open a command window.
 - b. Navigate to the path where the Information Center is installed. By default, the DB2 Information Center is installed in the `<Program Files>\IBM\DB2 Information Center\Version 9.7` directory, where `<Program Files>` represents the location of the Program Files directory.
 - c. Navigate from the installation directory to the `doc\bin` directory.
 - d. Run the `ic-update.bat` file:

```
ic-update.bat
```

Results

The DB2 Information Center restarts automatically. If updates were available, the Information Center displays the new and updated topics. If Information Center updates were not available, a message is added to the log. The log file is located in `doc\eclipse\configuration` directory. The log file name is a randomly generated number. For example, `1239053440785.log`.

Manually updating the DB2 Information Center installed on your computer or intranet server

If you have installed the DB2 Information Center locally, you can obtain and install documentation updates from IBM.

About this task

Updating your locally-installed *DB2 Information Center* manually requires that you:

1. Stop the *DB2 Information Center* on your computer, and restart the Information Center in stand-alone mode. Running the Information Center in stand-alone mode prevents other users on your network from accessing the Information Center, and allows you to apply updates. The Workstation version of the DB2 Information Center always runs in stand-alone mode. .
2. Use the Update feature to see what updates are available. If there are updates that you must install, you can use the Update feature to obtain and install them

Note: If your environment requires installing the *DB2 Information Center* updates on a machine that is not connected to the internet, mirror the update site to a local file system using a machine that is connected to the internet and has the *DB2 Information Center* installed. If many users on your network will be

installing the documentation updates, you can reduce the time required for individuals to perform the updates by also mirroring the update site locally and creating a proxy for the update site.

If update packages are available, use the Update feature to get the packages. However, the Update feature is only available in stand-alone mode.

3. Stop the stand-alone Information Center, and restart the *DB2 Information Center* on your computer.

Note: On Windows 2008, Windows Vista (and higher), the commands listed later in this section must be run as an administrator. To open a command prompt or graphical tool with full administrator privileges, right-click the shortcut and then select **Run as administrator**.

Procedure

To update the *DB2 Information Center* installed on your computer or intranet server:

1. Stop the *DB2 Information Center*.
 - On Windows, click **Start** → **Control Panel** → **Administrative Tools** → **Services**. Then right-click **DB2 Information Center** service and select **Stop**.
 - On Linux, enter the following command:

```
/etc/init.d/db2icdv97 stop
```
2. Start the Information Center in stand-alone mode.
 - On Windows:
 - a. Open a command window.
 - b. Navigate to the path where the Information Center is installed. By default, the *DB2 Information Center* is installed in the *Program_Files\IBM\DB2 Information Center\Version 9.7* directory, where *Program_Files* represents the location of the Program Files directory.
 - c. Navigate from the installation directory to the *doc\bin* directory.
 - d. Run the *help_start.bat* file:

```
help_start.bat
```
 - On Linux:
 - a. Navigate to the path where the Information Center is installed. By default, the *DB2 Information Center* is installed in the */opt/ibm/db2ic/V9.7* directory.
 - b. Navigate from the installation directory to the *doc/bin* directory.
 - c. Run the *help_start* script:

```
help_start
```

The systems default Web browser opens to display the stand-alone Information Center.

3. Click the **Update** button (). (JavaScript™ must be enabled in your browser.) On the right panel of the Information Center, click **Find Updates**. A list of updates for existing documentation displays.
4. To initiate the installation process, check the selections you want to install, then click **Install Updates**.
5. After the installation process has completed, click **Finish**.
6. Stop the stand-alone Information Center:
 - On Windows, navigate to the installation directory's *doc\bin* directory, and run the *help_end.bat* file:

help_end.bat

Note: The help_end batch file contains the commands required to safely stop the processes that were started with the help_start batch file. Do not use Ctrl-C or any other method to stop help_start.bat.

- On Linux, navigate to the installation directory's doc/bin directory, and run the help_end script:

```
help_end
```

Note: The help_end script contains the commands required to safely stop the processes that were started with the help_start script. Do not use any other method to stop the help_start script.

7. Restart the *DB2 Information Center*.

- On Windows, click **Start** → **Control Panel** → **Administrative Tools** → **Services**. Then right-click **DB2 Information Center** service and select **Start**.
- On Linux, enter the following command:

```
/etc/init.d/db2icdv97 start
```

Results

The updated *DB2 Information Center* displays the new and updated topics.

DB2 tutorials

The DB2 tutorials help you learn about various aspects of DB2 products. Lessons provide step-by-step instructions.

Before you begin

You can view the XHTML version of the tutorial from the Information Center at <http://publib.boulder.ibm.com/infocenter/db2help/>.

Some lessons use sample data or code. See the tutorial for a description of any prerequisites for its specific tasks.

DB2 tutorials

To view the tutorial, click the title.

“pureXML®” in *pureXML Guide*

Set up a DB2 database to store XML data and to perform basic operations with the native XML data store.

“Visual Explain” in *Visual Explain Tutorial*

Analyze, optimize, and tune SQL statements for better performance using Visual Explain.

DB2 troubleshooting information

A wide variety of troubleshooting and problem determination information is available to assist you in using DB2 database products.

DB2 documentation

Troubleshooting information can be found in the *DB2 Troubleshooting Guide* or the Database fundamentals section of the *DB2 Information Center*. There you will find information about how to isolate and identify problems using

DB2 diagnostic tools and utilities, solutions to some of the most common problems, and other advice on how to solve problems you might encounter with your DB2 database products.

DB2 Technical Support Web site

Refer to the DB2 Technical Support Web site if you are experiencing problems and want help finding possible causes and solutions. The Technical Support site has links to the latest DB2 publications, TechNotes, Authorized Program Analysis Reports (APARs or bug fixes), fix packs, and other resources. You can search through this knowledge base to find possible solutions to your problems.

Access the DB2 Technical Support Web site at http://www.ibm.com/software/data/db2/support/db2_9/

Terms and Conditions

Permissions for the use of these publications is granted subject to the following terms and conditions.

Personal use: You may reproduce these Publications for your personal, non commercial use provided that all proprietary notices are preserved. You may not distribute, display or make derivative work of these Publications, or any portion thereof, without the express consent of IBM.

Commercial use: You may reproduce, distribute and display these Publications solely within your enterprise provided that all proprietary notices are preserved. You may not make derivative works of these Publications, or reproduce, distribute or display these Publications or any portion thereof outside your enterprise, without the express consent of IBM.

Except as expressly granted in this permission, no other permissions, licenses or rights are granted, either express or implied, to the Publications or any information, data, software or other intellectual property contained therein.

IBM reserves the right to withdraw the permissions granted herein whenever, in its discretion, the use of the Publications is detrimental to its interest or, as determined by IBM, the above instructions are not being properly followed.

You may not download, export or re-export this information except in full compliance with all applicable laws and regulations, including all United States export laws and regulations.

IBM MAKES NO GUARANTEE ABOUT THE CONTENT OF THESE PUBLICATIONS. THE PUBLICATIONS ARE PROVIDED "AS-IS" AND WITHOUT WARRANTY OF ANY KIND, EITHER EXPRESSED OR IMPLIED, INCLUDING BUT NOT LIMITED TO IMPLIED WARRANTIES OF MERCHANTABILITY, NON-INFRINGEMENT, AND FITNESS FOR A PARTICULAR PURPOSE.

Appendix B. Notices

This information was developed for products and services offered in the U.S.A. Information about non-IBM products is based on information available at the time of first publication of this document and is subject to change.

IBM may not offer the products, services, or features discussed in this document in other countries. Consult your local IBM representative for information on the products and services currently available in your area. Any reference to an IBM product, program, or service is not intended to state or imply that only that IBM product, program, or service may be used. Any functionally equivalent product, program, or service that does not infringe any IBM intellectual property right may be used instead. However, it is the user's responsibility to evaluate and verify the operation of any non-IBM product, program, or service.

IBM may have patents or pending patent applications covering subject matter described in this document. The furnishing of this document does not grant you any license to these patents. You can send license inquiries, in writing, to:

IBM Director of Licensing
IBM Corporation
North Castle Drive
Armonk, NY 10504-1785
U.S.A.

For license inquiries regarding double-byte character set (DBCS) information, contact the IBM Intellectual Property Department in your country or send inquiries, in writing, to:

Intellectual Property Licensing
Legal and Intellectual Property Law
IBM Japan, Ltd.
3-2-12, Roppongi, Minato-ku, Tokyo 106-8711 Japan

The following paragraph does not apply to the United Kingdom or any other country/region where such provisions are inconsistent with local law:

INTERNATIONAL BUSINESS MACHINES CORPORATION PROVIDES THIS PUBLICATION "AS IS" WITHOUT WARRANTY OF ANY KIND, EITHER EXPRESS OR IMPLIED, INCLUDING, BUT NOT LIMITED TO, THE IMPLIED WARRANTIES OF NON-INFRINGEMENT, MERCHANTABILITY, OR FITNESS FOR A PARTICULAR PURPOSE. Some states do not allow disclaimer of express or implied warranties in certain transactions; therefore, this statement may not apply to you.

This information could include technical inaccuracies or typographical errors. Changes are periodically made to the information herein; these changes will be incorporated in new editions of the publication. IBM may make improvements and/or changes in the product(s) and/or the program(s) described in this publication at any time without notice.

Any references in this information to non-IBM Web sites are provided for convenience only and do not in any manner serve as an endorsement of those Web

sites. The materials at those Web sites are not part of the materials for this IBM product and use of those Web sites is at your own risk.

IBM may use or distribute any of the information you supply in any way it believes appropriate without incurring any obligation to you.

Licensees of this program who wish to have information about it for the purpose of enabling: (i) the exchange of information between independently created programs and other programs (including this one) and (ii) the mutual use of the information that has been exchanged, should contact:

IBM Canada Limited
Office of the Lab Director
8200 Warden Avenue
Markham, Ontario
L6G 1C7
CANADA

Such information may be available, subject to appropriate terms and conditions, including, in some cases, payment of a fee.

The licensed program described in this document and all licensed material available for it are provided by IBM under terms of the IBM Customer Agreement, IBM International Program License Agreement, or any equivalent agreement between us.

Any performance data contained herein was determined in a controlled environment. Therefore, the results obtained in other operating environments may vary significantly. Some measurements may have been made on development-level systems, and there is no guarantee that these measurements will be the same on generally available systems. Furthermore, some measurements may have been estimated through extrapolation. Actual results may vary. Users of this document should verify the applicable data for their specific environment.

Information concerning non-IBM products was obtained from the suppliers of those products, their published announcements, or other publicly available sources. IBM has not tested those products and cannot confirm the accuracy of performance, compatibility, or any other claims related to non-IBM products. Questions on the capabilities of non-IBM products should be addressed to the suppliers of those products.

All statements regarding IBM's future direction or intent are subject to change or withdrawal without notice, and represent goals and objectives only.

This information may contain examples of data and reports used in daily business operations. To illustrate them as completely as possible, the examples include the names of individuals, companies, brands, and products. All of these names are fictitious, and any similarity to the names and addresses used by an actual business enterprise is entirely coincidental.

COPYRIGHT LICENSE:

This information contains sample application programs in source language, which illustrate programming techniques on various operating platforms. You may copy, modify, and distribute these sample programs in any form without payment to IBM, for the purposes of developing, using, marketing or distributing application

programs conforming to the application programming interface for the operating platform for which the sample programs are written. These examples have not been thoroughly tested under all conditions. IBM, therefore, cannot guarantee or imply reliability, serviceability, or function of these programs. The sample programs are provided "AS IS", without warranty of any kind. IBM shall not be liable for any damages arising out of your use of the sample programs.

Each copy or any portion of these sample programs or any derivative work must include a copyright notice as follows:

© (*your company name*) (*year*). Portions of this code are derived from IBM Corp. Sample Programs. © Copyright IBM Corp. *_enter the year or years_*. All rights reserved.

Trademarks

IBM, the IBM logo, and [ibm.com](http://www.ibm.com)[®] are trademarks or registered trademarks of International Business Machines Corp., registered in many jurisdictions worldwide. Other product and service names might be trademarks of IBM or other companies. A current list of IBM trademarks is available on the Web at "Copyright and trademark information" at www.ibm.com/legal/copytrade.shtml.

The following terms are trademarks or registered trademarks of other companies

- Linux is a registered trademark of Linus Torvalds in the United States, other countries, or both.
- Java and all Java-based trademarks and logos are trademarks of Sun Microsystems, Inc. in the United States, other countries, or both.
- UNIX is a registered trademark of The Open Group in the United States and other countries.
- Intel, Intel logo, Intel Inside[®], Intel Inside logo, Intel[®] Centrino[®], Intel Centrino logo, Celeron[®], Intel[®] Xeon[®], Intel SpeedStep[®], Itanium, and Pentium are trademarks or registered trademarks of Intel Corporation or its subsidiaries in the United States and other countries.
- Microsoft, Windows, Windows NT[®], and the Windows logo are trademarks of Microsoft Corporation in the United States, other countries, or both.

Other company, product, or service names may be trademarks or service marks of others.

Index

A

- about this book 1
- ActiveX data objects
 - DB2 Data Server Client support 16
- AIX
 - CD mounting 48
 - DVD mounting 48
 - installing
 - DB2 Connect server products 45, 47
- application development
 - IBM Data Server Client
 - details 16
 - JDBC
 - host data access 7
- applications
 - ODBC 115

B

- bidirectional CCSID support
 - language support 114
- binding
 - utilities
 - DB2 Connect 115
- books
 - ordering 126

C

- call level interface (CLI)
 - IBM Data Server Client support 16
- CDs
 - mounting
 - AIX 48
 - HP-UX 53
 - Linux 58
 - Solaris Operating System 62
- clients
 - overview 7, 13
 - remote 7
- code pages
 - conversion
 - exceptions 114
 - supported 111
- coded character set identifier (CCSID)
 - bidirectional languages 114
- command-line processor (CLP)
 - IBM Data Server Client 16
- commands
 - db2licm
 - setting license policy 85
 - db2osconf
 - determining kernel configuration parameter values 35
 - db2rfe
 - enabling root-based features 76
 - overcoming limitations on non-root installations 72
 - db2secv82 69
 - db2setup
 - displaying DB2 Setup wizard in your national language 111

- communication protocols
 - DRDA host access configuration 98
- communications
 - Control Center 14
- configuration
 - connections to mainframe 103
 - connectivity
 - Configuration Assistant 103
 - DB2 Connect server products 41
 - TCP/IP
 - using CLP 104
- Configuration Assistant (CA)
 - configuring
 - connections to host database servers 103
 - connections to System i database servers 103
 - database connections 108
 - Discovery feature 107
 - testing database connections 109
- connections
 - Configuration Assistant 13
 - DRDA hosts through communications server 98
 - overview 13
- Control Center
 - overview 14
- conversion
 - character 114

D

- DAS (DB2 administration server)
 - see DB2 administration server (DAS) 14
- data
 - access
 - DB2 Connect 8
 - JDBC 7
- database administration tools
 - overview 14
- database applications
 - developing 115
- Database Connection Services (DCS) directory
 - removing entries 109
- databases
 - adding manually 108
 - connections
 - configuring 107, 108
 - testing 109
 - host 97
- DB2 administration server (DAS)
 - overview 14
- DB2 Connect
 - DB2 for VSE & VM 101
 - host support 5, 8
 - IBM i connections 95
 - installing
 - non-Administrator 68
 - prerequisites 91
 - overview 5, 8
 - products 5
 - server products
 - configuring 41
 - installing (AIX) 45, 47

- DB2 Connect (*continued*)
 - server products (*continued*)
 - installing (HP-UX) 51, 53
 - installing (Linux) 55, 57
 - installing (overview) 41
 - installing (Solaris Operating System) 59, 61
 - installing (Windows) 63, 64
 - post-upgrade tasks 26
 - pre-upgrade tasks 23
 - System i support 5
 - upgrading
 - overview 21, 22
 - procedure 24
 - zSeries support 5
- DB2 for VM & VSE
 - preparing for connections from DB2 Connect 101
- DB2 for z/OS
 - administering using Control Center 14
 - updating system tables 100
- DB2 Information Center
 - languages 127
 - updating 128, 129
 - versions 127
- DB2 Setup wizard
 - language identifiers 111
- DB2ADMNS group
 - adding users 69
- db2licm command
 - managing licenses 81
 - registering licenses 85
 - setting license policy 85
- db2osconf command
 - determining kernel configuration parameter values 35
- db2rfe command
 - enabling root features 72, 76
- db2setup command
 - language setting 111
- DB2USERS user group
 - adding users 69
- default language setting
 - Windows 112
- directory schema
 - extending
 - Windows 68
- directory structures
 - root installations compared to non-root installations 71
- discovery feature
 - configuring database connection 107
- disk space
 - requirements 43
- documentation
 - overview 123
 - PDF files 123
 - printed 123
 - terms and conditions of use 132
- dropping
 - non-root instances 78
- DVDs
 - mounting
 - AIX 48
 - HP-UX 53
 - Linux 58
 - Solaris Operating System 62

E

- embedded SQL applications
 - IBM Data Server Client support 16
- examples
 - DB2 Connect 7

F

- fix packs
 - applying 87
 - non-root installations 77

H

- help
 - configuring language 127
 - SQL statements 127
- host databases
 - client connections 91
 - configuring TCP/IP 104
- HP-UX
 - installing
 - DB2 Connect servers 51, 53
 - kernel configuration parameters
 - modifying 35
 - recommended values 35
 - mounting media 53

I

- IBM data server clients
 - connecting to 91
- IBM Data Server Driver for JDBC and SQLJ
 - levels for DB2 versions 31
- IBM i
 - DB2 Connect 5
- installation
 - DB2 Connect server products 41
 - DB2 database user accounts (Windows) 65
 - DB2 for Linux on zSeries 57
 - DB2 products
 - as non-root user 74
- instances
 - removing 78
- interface languages
 - changing
 - UNIX 113
 - Windows 112
 - overview 111

J

- Java
 - DB2 product support 31
 - host database access 7
 - IBM Data Server Client support 16
- JDBC
 - drivers
 - details 31
 - IBM Data Server Client support 16

K

- kernel configuration parameters
 - HP-UX
 - db2osconf command 35
 - modifying 35
 - recommended 35
 - Linux 35
 - overview 35
 - Solaris Operating System 37

L

- LANG environment variable
 - setting 111, 113
- languages
 - bidirectional support 114
 - DB2 interface 111, 112
 - DB2 Setup wizard for language identifiers 111
- License Center
 - managing licenses 81
 - registering licenses 83
 - setting license policies 84
- license policies
 - setting
 - db2licm command 85
 - License Center 84
- licenses
 - activating 81
 - overview 81
 - registering
 - db2licm command 85
 - License Center 83
- Linux
 - installing
 - DB2 Connect server products 55, 57
 - DB2 databases on zSeries 57
 - modifying kernel parameters 35
 - mounting
 - CDs 58
 - DVDs 58
 - removing
 - DB2 (root) 120
 - uninstalling DB2
 - non-root instances 78
 - root 120
- locales
 - DB2 interface languages 111

M

- mainframe access
 - configuring 103, 107
- memory
 - requirements
 - overview 43
- midrange servers
 - configuring connections 103
- mounting CDs or DVDs
 - AIX 48
 - HP-UX 53
 - Linux 58
 - Solaris Operating System 62

N

- national language support (NLS)
 - converting character data 114
 - displaying DB2 Setup wizard 111
- non-root installations
 - differences 71
 - directory structure 71
 - enabling root-based features 76
 - fix packs 77
 - installing 74
 - limitations 72
 - overview 71
 - uninstalling 78
- non-root instances
 - dropping 78
 - removing 78
- notices 133

O

- ODBC
 - enabled applications 115
- OLE
 - IBM Data Server Client support 16
- ordering DB2 books 126

P

- post-upgrade tasks
 - DB2 Connect servers 26
- pre-upgrade tasks
 - DB2 Connect servers 23
- precompilers
 - IBM Data Server Client support 16
- problem determination
 - information available 131
 - tutorials 131

R

- removing
 - DB2 (root)
 - Linux 120
 - UNIX 120
- root installations
 - comparison with non-root installations 71
 - directory structure 71
- root-based features
 - non-root installations 76

S

- scenarios
 - DB2 Connect 7
- SDKs
 - product levels 31
- security
 - user groups 69
- servers
 - communications 14
- Solaris Operating Environment
 - installation requirements
 - DB2 Connect server products 61

- Solaris Operating System
 - installing
 - DB2 Connect server products 59
 - modifying kernel parameters 37
 - mounting CDs or DVDs 62
- SQL
 - viewing with Visual Explain 14
- SQL statements
 - help
 - displaying 127
- SQLJ
 - IBM Data Server Client support 16
- System i
 - database servers
 - configuring TCP/IP 104
 - DB2 Connect support 5
- System z
 - support for DB2 Connect 5

T

- TCP/IP
 - configuring
 - host connections 98
 - host database servers 104
 - System i database servers 104
 - DB2 for z/OS configuration 97
- terms and conditions
 - publications 132
- territory codes
 - page support 114
- testing
 - database connections 109
- troubleshooting
 - online information 131
 - tutorials 131
- tutorials
 - list 131
 - problem determination 131
 - troubleshooting 131
 - Visual Explain 131

U

- uninstalling
 - DB2 Connect 119
 - DB2 database products
 - Windows 119
 - non-root installations 78
 - root installations 120
- UNIX
 - changing DB2 interface language 113
 - removing
 - DB2 (root) 120
 - DB2 non-root instances 78
 - uninstalling DB2
 - root 120
- updates
 - DB2 Information Center 128, 129
- upgrades
 - DB2 Connect
 - overview 21, 22
 - procedure 24
- user accounts
 - DB2 Administration Server (Windows) 65
 - instance user (Windows) 65

- user accounts (*continued*)
 - required for installation (Windows) 65
- user groups
 - DB2ADMNS 69
 - DB2USERS 69
 - security 69
- utilities
 - binding 115

V

- VTAM
 - preparing z/OS for connections from DB2 Connect 97

W

- Windows
 - default language setting 112
 - installing
 - DB2 Connect (with non-Administrator access) 68
 - DB2 Connect server products (procedure) 63
 - DB2 Connect server products (requirements) 64
 - uninstalling DB2 119
 - user accounts
 - DB2 server product installation 65

Z

- z/OS
 - configuring DB2 database systems 100
- zSeries
 - installing DB2 Database for Linux 57



Printed in USA

SC27-2433-01



Spine information:

IBM DB2 Connect 9.7 **Version 9 Release 7**

Installing and Configuring DB2 Connect Servers

