

IBM InfoPrint Manager for Windows NT



PSF Direct: AS/400 Configuration (3/24/2000)

AS/400 Local or Remote Token-Ring Example: Table of Contents

I. Overview on PSF Direct and Communication Server for NT	1
What is PSF Direct?	1
What is IBM SecureWay Communications Server for NT?	2
What are the Available Network Connections?	3
II. Configuration Planning	4
Understanding PSF Direct Configuration Requirements	4
Application View of an SNA Network	5
Network Internals View of an SNA Network	7
Key Configuration Parameter Interrelationships	8
Preconfiguration Decisions for all PSF Direct Examples	13
Defining devices for IBM SecureWay Communications Server and Infoprint Windows NT	14
Using an alternate token-ring address for a Windows NT server	14
Decide whether to define a dependent or an independent LU	15
Configuring an LU 6.2 Partner LU on your Infoprint Windows NT Server	16
Enable SNA API Clients on your Infoprint Windows NT server	16

Infoprint Manager for Windows NT and Windows 2000

<u>III. Local or Remote AS/400 Token-Ring</u>	17
<u>AS/400 Host Configuration Examples</u>	17
<u>AS/400 Line Descriptions</u>	18
<u>Advanced Program-to-Program Controller Descriptions</u>	21
<u>Host Printer Descriptions</u>	24
<u>Accessing the Communications Server for NT Profiles</u>	26
<u>Communications Server for NT Configuration Profile Examples</u>	27
<u>AS/400 Node setup</u>	29
<u>AS/400 Device configuration</u>	32
<u>SNA API Client Connection</u>	37
<u>AS/400 Peer connection configuration</u>	39
<u>AS/400 Partner LU 6.2 configuration</u>	44
<u>AS/400 Local LU 6.2 configuration</u>	47
<u>AS/400 Mode Configuration</u>	50
<u>AS/400 Transaction program configuration</u>	53

Infoprint Manager for Windows NT and Windows 2000

<u>Guidelines for Configuring Local or Remote AS/400 Token-Ring</u>	56
<u>AS/400 Host Configuration Information</u>	56
<u>Specifying Communications Server for NT Configuration Profiles</u> . .	57
<u>Node Setup</u>	57
<u>Device Configuration</u>	60
<u>AS/400 Peer-to-Peer Connection Configuration</u>	64
<u>Partner LU 6.2 Configuration</u>	66
<u>Local LU 6.2 Configuration</u>	67
<u>Configuring Modes</u>	69
<u>Transaction Program Configuration</u>	71

Infoprint Manager for Windows NT and Windows 2000

<u>Local or Remote AS/400 Configuration Worksheets</u>	73
<u>AS/400 Worksheet Example</u>	74
<u>AS/400 Worksheet Sample</u>	75
<u>Starting an IBM SecureWay Communications Server for NT Configuration</u> . . .	76
<u>IV. Configuring PSF Direct</u>	77
<u>Creating and Configuring an Infoprint PSF Direct Destination (printer)</u> .	77
<u>Using the Infoprint Manager Administration GUI</u> . .	78
<u>Using the Infoprint Manager Management Console</u>	78
<u>Defining the PSF Direct Host Receiver</u>	78
<u>Starting a PSF Direct Host Receiver</u>	80
<u>Stopping a PSF Direct Host Receiver</u>	80
<u>Displaying the Status of a PSF Direct Destination on the Windows NT/2000 System</u>	81
<u>Displaying the Status of a PSF Direct Destination on the Host System</u>	83

Infoprint Manager for Windows NT and Windows 2000

<u>Using One Infoprint Actual Destination to Print Data from Multiple Sources</u>	83
<u>Switching between Data Sources</u>	84
<u>Manually Stopping a PSF Direct Host Receiver</u>	84
<u>Automatically Stopping a PSF Direct Host Receiver</u>	85
<u>Automatically Stopping Printing from the IBM Infoprint Windows NT Server</u>	85
<u>Controlling the Wait Period for a PSF Direct Host Receiver</u>	85
<u>Controlling the Wait Period for Printing from an IBM Infoprint Windows NT Server</u>	86
<u>Sharing an Infoprint Actual Destination</u>	87
<u>Host PSF Program Configuration: Examples</u>	87
<u>Infoprint Actual Destination: PSF Tuning Options</u>	88
<u>PSF Direct Host Receiver: Examples</u>	89
<u>Displaying the Status of a Shared Infoprint Actual Destination</u>	90

Overview on PSF Direct and Communication Server for NT

The following topic contains an overview of the components you need to configure PSF Direct on SNA networks. This topic contains the following:

- [What is PSF Direct?](#)
- [What is IBM SecureWay Communications Server for NT?](#)
- [What are the Available Network Connections?](#)

What is PSF Direct?

PSF Direct provides a direct connection between an MVS, VSE, VM, or AS/400 system and a printer defined to IBM Infoprint Manager for NT. PSF Direct gives you control of key print processes from your mainframe console: an Infoprint physical printer appears to be directly attached to your mainframe system. Jobs print without delay because they are not spooled by the NT workstation. Because the mainframe controls the print process, it returns job-completion and error messages to the mainframe.

PSF Direct uses Communication Server LU6.2 protocols to communicate between the mainframe and the NT system; then PSF Direct uses one of several protocols to communicate between the NT system and the printer:

- TCP/IP
- Channel
- Parallel/Serial

These protocols provide you with access to TCP/IP, Channel, or Parallel/Serial printers that otherwise you might not be able to attach from the mainframe.

To use PSF Direct, you need the IBM SecureWay Communications Server product to communicate between the mainframe and NT. You create printer definitions on the mainframe so that print jobs can be directed to the NT printer. Then, you define the printer to the IBM Infoprint server on NT.

After PSF Direct is installed, you send the job to the printer, using normal print-submission processes. Because PSF Direct is a direct pipeline to the printer, you need to end the PSF Direct session before you can use the printer to print from another mainframe or from IBM Infoprint Manager for NT.

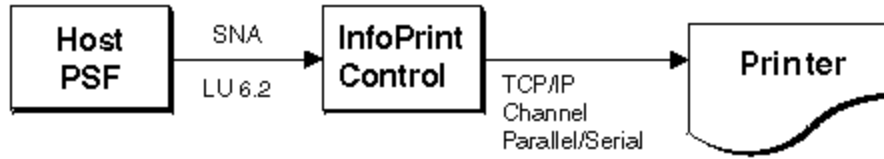

What is IBM SecureWay Communications Server for NT?

The IBM SecureWay Communications Server for NT is required to configure and to use PSF Direct. IBM SecureWay Communications Server is an implementation of SNA for the NT operating system running on the NT workstation. It enables an NT workstation to communicate with other nodes in an SNA network.

Infoprint Manager for NT allows you to create a PSF Direct Host Receiver whether or not you have completed the IBM SecureWay Communications Server node configuration.

PSF Direct requires IBM SecureWay Communications Server for NT system software Version 6, Release 01, with maintenance that includes the following authorized program analysis report (APAR) fixes:

- APAR JR13453
- APAR JR14098
- APAR JR13599

Note that the second APAR (JR13599) is necessary only if you will be creating more than one Communications Server profile for Dependent LUs.

Because Infoprint Manager for NT allows you to create a PSF Direct Host Receiver whether or not you have completed the IBM SecureWay Communications Server node configuration, it does not matter whether you install Infoprint Manager or Communications Server first.

To install IBM SecureWay Communications Server from the CD-ROM:

1. Select the **Install Products** icon that appears on the main window.
2. Choose a **Server** install.
3. From the **Communications Server Installation**, you should select only the **Communications Server for Windows NT** option to use the PSF Direct function.

Once you have completed the installation, create shortcuts for both the **SNA Node Configuration** interface (a default path of `C:\IBMCS\pcscfg.exe` where *C* is the drive where you installed IBM SecureWay Communications Server for NT) and the **Communications Server Node Operations** interface (a default path of `C:\IBMCS\pcsnops.exe` where *C* is the drive where you installed IBM SecureWay Communications Server for NT), so they can be easily invoked from your desktop.

What are the Available Network Connections?

This document includes detailed examples and guidelines for five common SNA configurations. The diagrams in this section illustrate the five network configurations, with references to where more detailed information is provided.

1. Local or Remote 37xx Token-Ring Configuration:

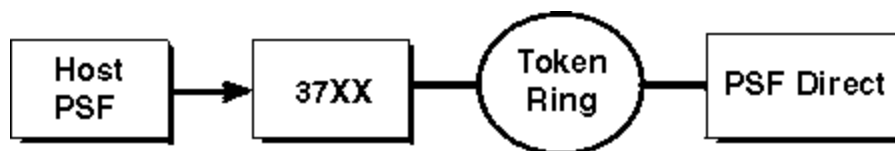

2. Local 3172 Token-Ring Configuration:

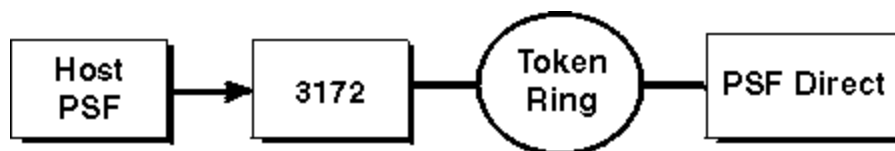

3. Local 3174 Token-Ring Gateway Configuration:

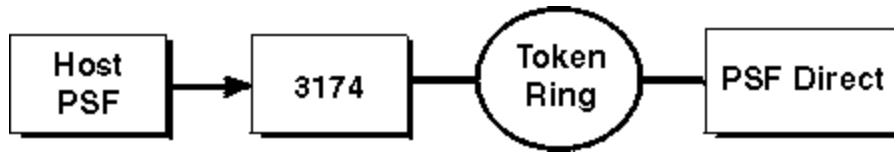

4. Remote 3174 Token-Ring Gateway Configuration:

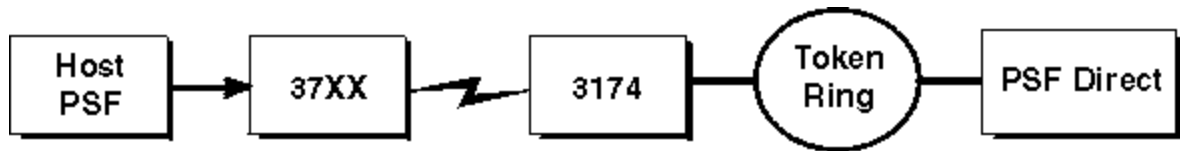

Configuration Planning

All PSF Direct configuration examples require that you understand the following information before creating each individual configuration:

- [Understanding PSF Direct Configuration Requirements](#)
- [Preconfiguration Decisions for all PSF Direct Examples](#)
- [Host Configuration Examples](#)
- [Accessing the Communications Server for NT Profiles](#)
- [Communications Server for NT Configuration Profile Examples](#)

Understanding PSF Direct Configuration Requirements

An SNA network provides powerful communication capabilities to applications without requiring that the applications be aware of the equipment and transmission facilities that comprise the network. So, an SNA application like PSF Direct can communicate using an SDLC telecommunications link between two continents or a Token-Ring LAN in a single room.

To configure an SNA application, one normally need only identify the communication partner and the guidelines for exchanging data.

To configure an SNA network, the internal components of the network and details of their operation must be described.

Considering two views of an SNA network, an [application view](#) and a [network internals view](#), aids in understanding PSF Direct configuration requirements. An overview of the [Key Configuration Parameter Interrelationships](#) when defining logical unit (LU) names follows.

Application View of an SNA Network

An SNA network provides two access points for communication and a logical connection between the two access points. In SNA terminology, the access points are **logical units (LUs)** and the connection between them is a **session**. A **mode** describes a session's characteristics, or guidelines for exchanging data.

The application view displayed in the figure below illustrates the interface that SNA provides to applications, such as the host PSF program and the PSF Direct component of Infoprint Manager. These applications are isolated from details of the internal components of the SNA network.

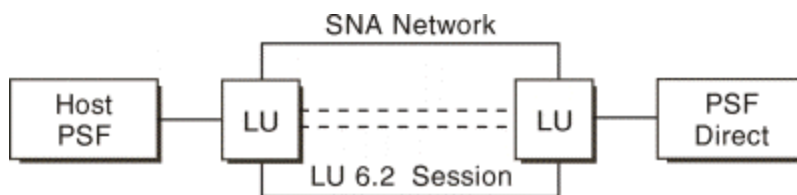

As the application view suggests, only a few values are required to configure the host PSF program and PSF Direct so they can communicate. The following figure displays the values used by both applications. Note that each configuration parameter references a logical unit or mode provided by the SNA network.

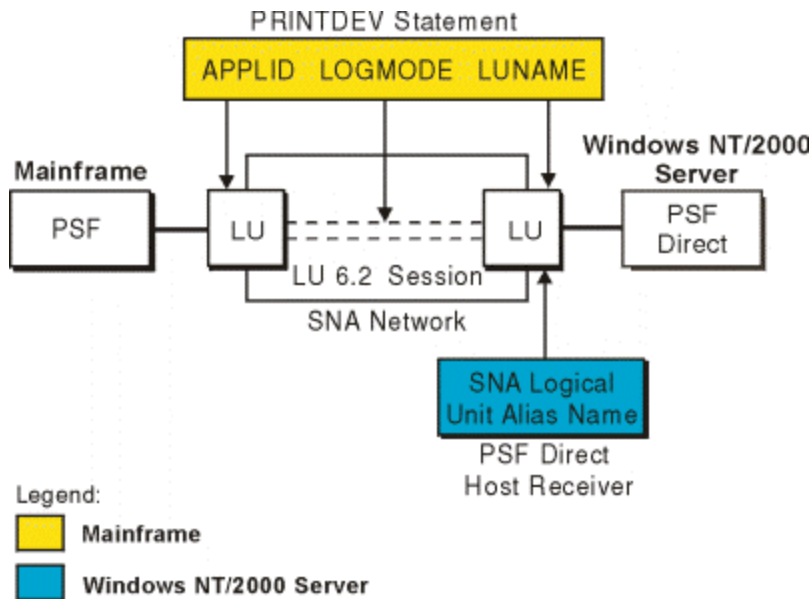

Host **PSF PRINTDEV** Statement Parameters:

APPLID

Specifies the name of the logical unit that the host PSF program uses.

LUNAME

Specifies the name of the logical unit that PSF Direct uses.

LOGMODE

Specifies the session characteristics for communication between the two logical units.

Individual modes, or mode entries, are grouped into a table that contains several modes. **LOGMODE** identifies a mode entry. You identify the mode table through the SNA network definitions for the logical unit that PSF Direct uses.

PSF Direct Host Receiver Parameters:

SNA Logical Unit Alias name

Specifies the name of the local ID that points to the logical unit that PSF Direct uses on the Windows NT server.

Because there may be several PSF Direct host receivers on an NT workstation and several NT workstations in an SNA network, each PSF Direct host receiver must have a unique logical unit name.

Network Internals View of an SNA Network

While the application view illustrates the relationship of an SNA network to the applications that use it, the network internals view aids in understanding the components of an SNA network and how they must be configured.

Network internals view for a 37xx Communications Controller:

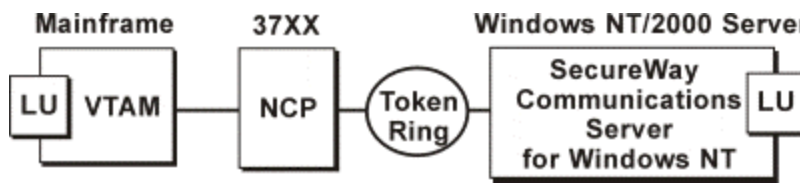

Network internals view for a Local 3172 Communications Controller:



Network internals view for a Local 3174 Communications Controller:



Network internals view for a Remote 3174 Communications Controller:

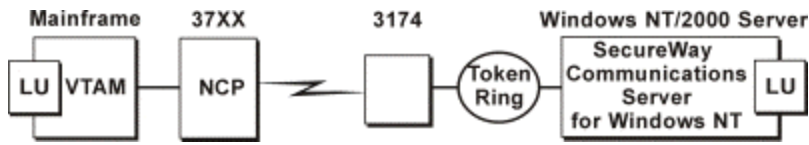

The network internals view illustrates that many components comprise an SNA network. Most of the components have detailed configuration requirements. Many of those requirements are described within the five configuration topics.

First, however, it is important to understand that several network components have configuration parameters whose values are related to configuration parameters for other network components. These interrelated parameters must be configured consistently to make end-to-end communication possible.

Several figures follow. They illustrate some of the key interrelationships among configuration parameters for SNA network components.

Key Configuration Parameter Interrelationships

The following image illustrates the interrelationships required when defining logical unit (LU) names:

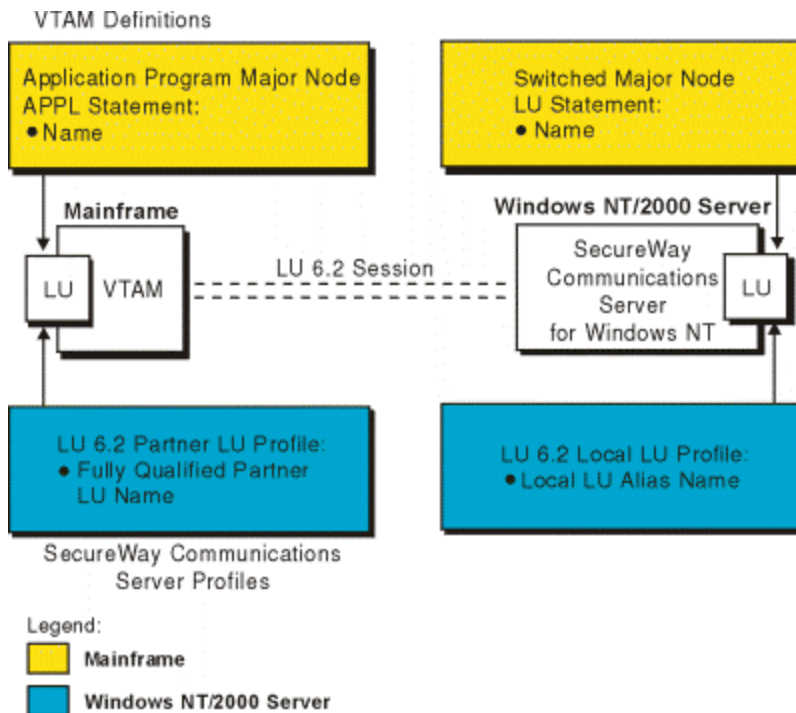

The following image illustrates the interrelationships required when defining the local address of the logical unit provided by SecureWay Communications Server for NT:

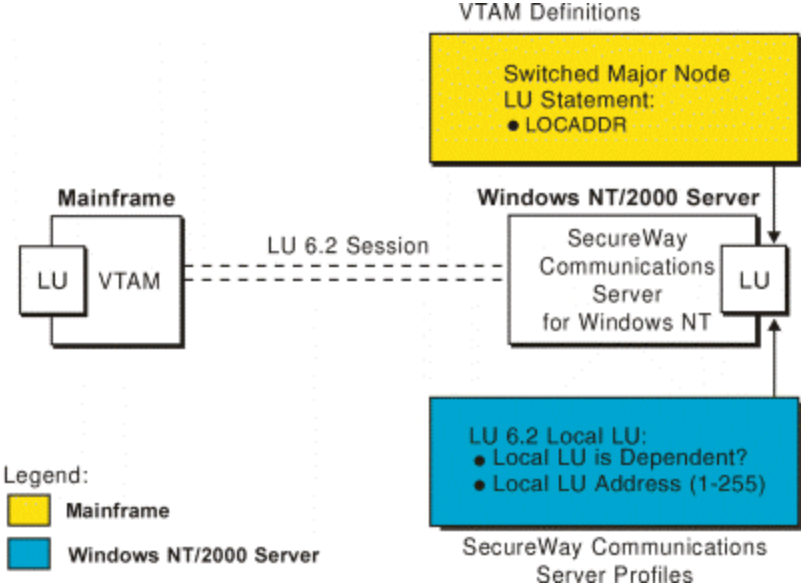

The following image illustrates the interrelationships required when defining session characteristics:

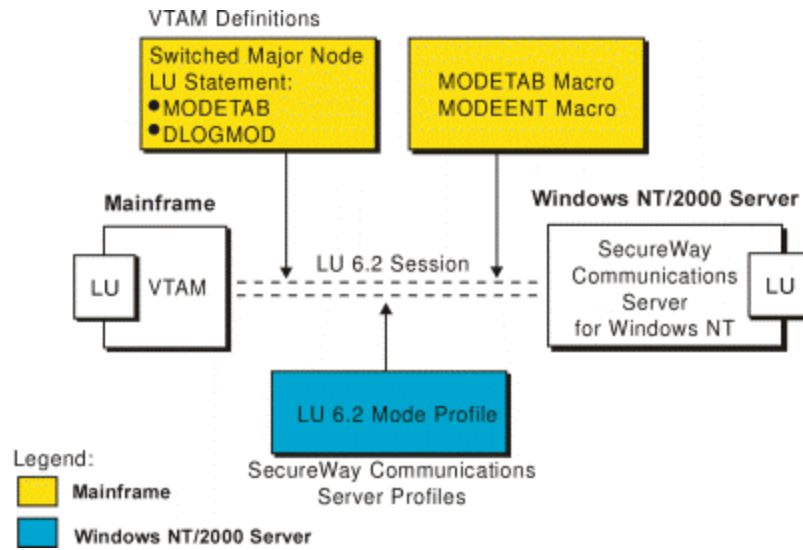

The following image illustrates the interrelationships required when defining the name of the physical unit/control point provided by SecureWay Communications Server for NT:

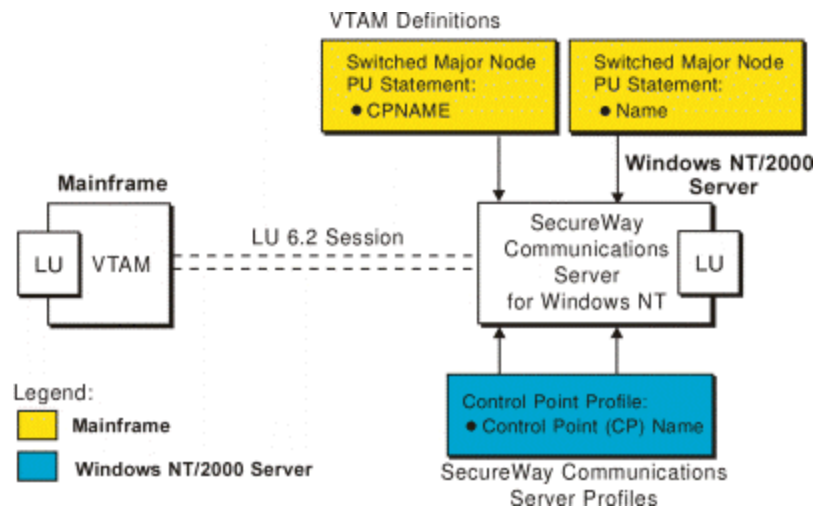

The following image illustrates the interrelationships required when defining the token-ring addresses used in the 37xx configuration:

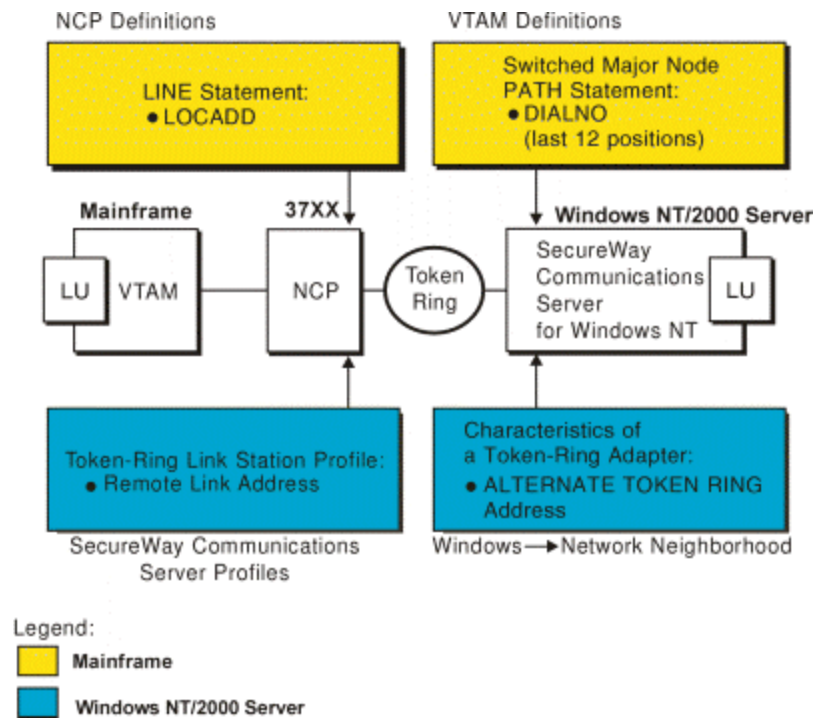

The following image illustrates the interrelationships required when defining the token-ring addresses used in the Local 3172 configuration:

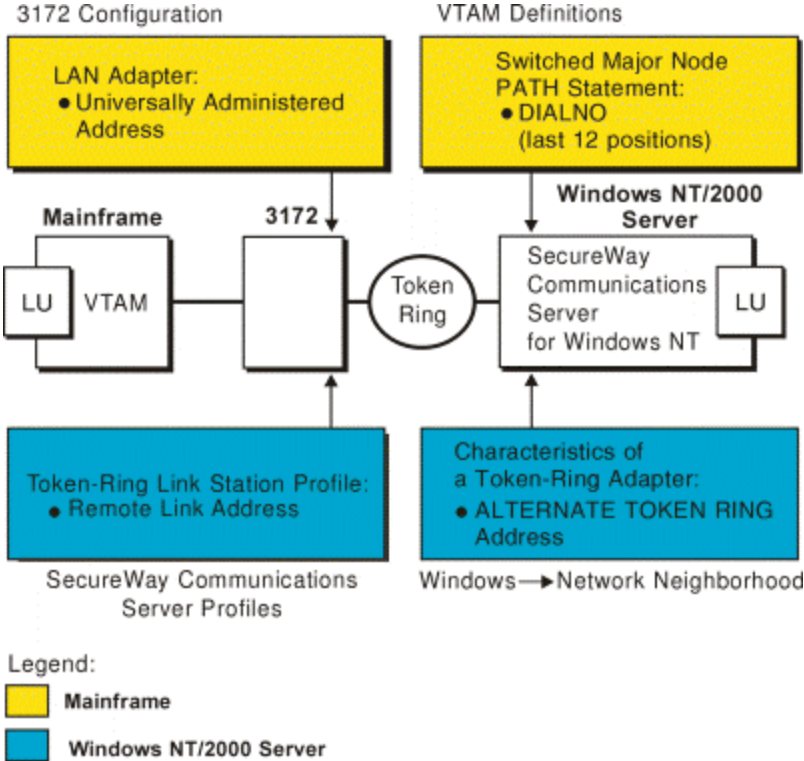

The following image illustrates the interrelationships required when defining the token-ring addresses used in either the Local or the Remote 3172 configuration:

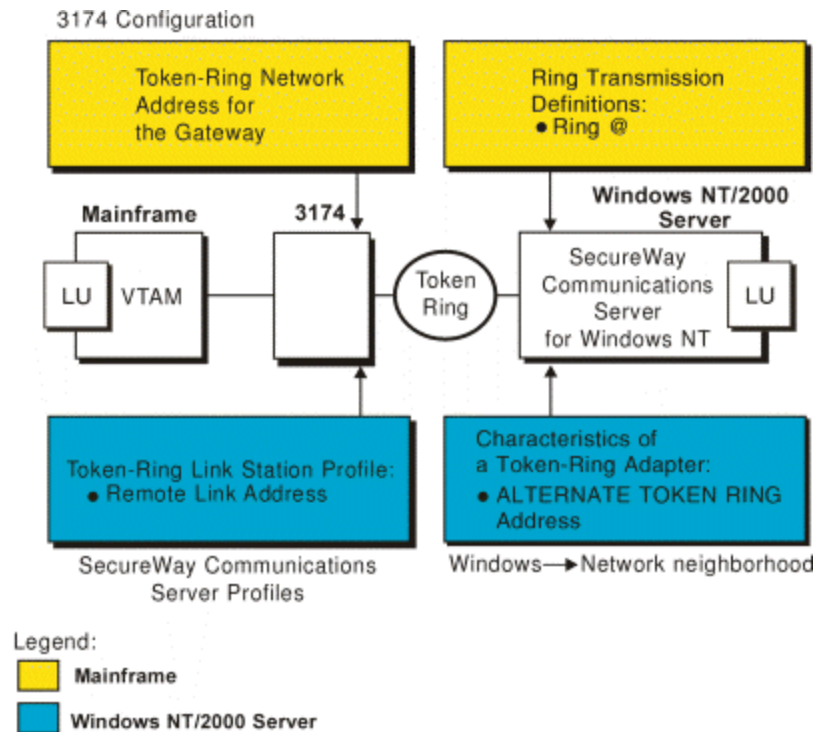

Preconfiguration Decisions for All PSF Direct Examples

Note that for each configuration example you must perform the following tasks, which are defined within the configuration examples:

- [Defining devices for IBM SecureWay Communications Server and Infoprint Windows NT](#)
- [Using an alternate token-ring address for a Windows NT server](#)
- [Decide whether to define a dependent or an independent LU](#)
- [Configuring an LU 6.2 Partner LU on your Infoprint Windows NT Server](#)
- [Enable SNA API Clients on your Infoprint Windows NT server](#)

Defining Devices for IBM SecureWay Communications Server and Infoprint Windows NT

Devices must be defined for both Communications Server and Infoprint Windows NT so that the token-ring (or ethernet) card can be used to carry the SNA data from the PSF host program. Usually, a device must be made available once, and then remains available, even after Windows NT is shutdown and restarted. For each configuration example, you accomplish this task through Device Configuration, the second of the IBM SecureWay Communications Server for NT configuration profiles provided in each example.

Using an Alternate Token-Ring Address for a Windows NT Server

A token-ring address, often called a **MAC address**, has 12 hexadecimal digits, for example, 10005AC8B0EA. Each device in a token-ring network must have a unique address. To facilitate unique token-ring addressing, every manufacturer assigns a distinct address called a **universal MAC address** to each token-ring adapter. By default, a token-ring adapter in a Windows NT server uses the token-ring address that the manufacturer assigned when the adapter was made. However, Windows NT systems allow you to define an **alternate token-ring address**, also called a **local MAC address**.

In some configurations, an alternate token-ring address might be necessary. For example, if the **DIALNO** operand is included in a VTAM switched major node **PATH** statement, an alternate token-ring address is generally required. The **DIALNO** operand accepts only digits in the 0-9 range; however, most universal MAC addresses (assigned by the manufacturer) include at least one digit in the A-F range. In these instances, it might be necessary to use an alternate token-ring address that does not contain any digits in the A-F range. Generally, the first four digits of alternate token-ring addresses must be 4000.

To assign an alternate token-ring address to an token-ring adapter in a Windows NT or Windows 2000 server, you must refer to the operating system online help because different levels of the operating systems can vary.

If you want to assign an alternate token-ring address to a token-ring adapter on a Microsoft Windows NT Version 4.00.1381 system, for example, use the following procedure:

1. Specify the **My Computer-->Control Panel-->Network** path.
2. Select the **Adapters** tab.
3. Highlight the token-ring adapter and click the **Properties...** button.
4. From the **IBM Auto 16/4 Token-Ring Adapter Card Setup** pop-up, specify the local MAC address in the Network Address field.
5. Shut down and reboot your Infoprint Windows NT server so the new address can take effect.

Decide whether to Define a Dependent or an Independent LU

You will usually add an LU 6.2 Local LU profile for each logical unit used by PSF Direct, whether the logical unit is dependent or independent. Whenever possible, you should define an independent LU, because they are easier to manage. With a dependent LU, you must assign a session ID and track its NAU address.

A dependent LU requires the following from the **Communications Server SNA Node Configuration** window:

1. Click the plus sign (+) next to **Host Resources** to access **Host Connections**.
2. Highlight **Host Connections** and select the **Create** option.
3. Fill in all the values on the **Define a LAN Connection** window, then specify **OK**.
4. At the **Do you wish to create and assign new LUs to this connection?** pop-up dialog, specify **YES**.
5. Fill in the **Host LU Definition** window, specifying a **base LU name** value.

An independent LU requires the following from the **Communications Server SNA Node Configuration** window:

1. Select and define **Peer Connections**, while leaving **Host Resources** empty.
2. Select the **Local LU 6.2 LUs** option under the **CPI-C and APPC** heading.
3. Specify the **Define a Local LU 6.2 (Basic)** window, leaving the **Dependent LU** unchecked.
4. Specify the **Define a Local LU 6.2 (Advanced)** window.

Configuring an LU 6.2 Partner LU on your Infoprint Windows NT Server

You must configure an LU 6.2 Partner LU profile for each logical unit used by a host PSF program. Some IBM SecureWay Communications Server for NT documentation indicates that an LU 6.2 Partner LU profile is not required if the local LU is an independent logical unit. However, because the logical unit used by the host PSF program does not support parallel sessions, IBM SecureWay Communications Server for NT requires an LU 6.2 profile in all PSF Direct configurations.

Enable SNA API Clients on your Infoprint Microsoft NT Server

Access these panels by clicking on the plus (+) sign next to **Client Resources** and right-clicking on the **SNA API Clients** box. Then, follow the instructions provided below:

1. From the **SNA Clients** panel, check the **Enable SNA API Client Services** box.
2. Single-click on the **OK** button at the bottom of the screen to save these specifications to the appropriate *.acg file, where * is the first-qualifier name of the .acg file that you named on the **Welcome to Communications Server Configuration!** window.

Local and Remote AS/400 Token-Ring

The following displays a view of a local or remote AS/400 Token-Ring configuration:

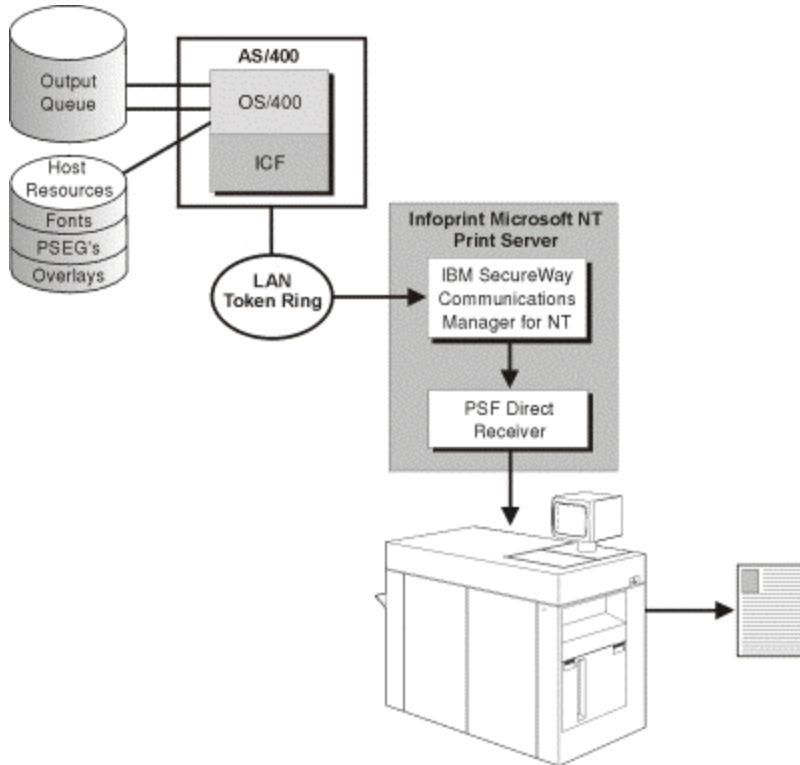

Host Configuration Examples

The following topics show the AS/400 commands and the resulting output for the following three aspects of a PSF Direct configuration that must be completed on the host AS/400 operating system:

- [AS/400 Line Descriptions](#)
- [Advanced Program-to-Program \(APPC\) Controller Descriptions](#)
- [Host Printer Device Description](#)

For more information about the configurations created by these three commands, see [AS/400 Host Configuration Information](#).

AS/400 Line Descriptions

To create a dedicated line for your AS/400, enter the following on your AS/400 Operating System:

```
CRTLINTRN LIND(line_name) RSRNAME(resource_name)
```

This command example will create output similar to the following:

```
5769SS1 V4R4M0 990521
```

```
Line description . . . . . : LIND          TRLANAS44
Option . . . . . : OPTION          *ALL
Category of line . . . . . :              *TRLAN
Resource name . . . . . : RSRNAME     CMN10
Online at IPL . . . . . : ONLINE      *YES
Vary on wait . . . . . : VRYWAIT     *NOWAIT
Network controller . . . . . : NETCTL   TRLANNET
Maximum controllers . . . . . : MAXCTL   256
Line speed . . . . . : LINESPEED     16M
Duplex . . . . . : DUPLEX            *HALF
Maximum frame size . . . . . : MAXFRAME 16388
LEC frame size . . . . . : LECFRAME
Activate LAN manager . . . . . : ACTLANMGR *YES
TRLAN manager logging level : TRNLOGLVL *OFF
Current logging level . . . . . :              *OFF
TRLAN manager mode . . . . . : TRNMGRMODE *OBSERVING
Log configuration changes . : LOGCFGCHG *LOG
Token-ring inform of beacon : TRNINFBCN  *YES
```



```

Local adapter address . . . : ADPTADR          400050103006
Exchange identifier . . . . : EXCHID           056E0102
Early token release . . . . : ELYTKNRLS       *YES
Error threshold level .. . . : THRESHOLD      *OFF
Message queue . . . . . . . : MSGQ           *SYSVAL
Current message queue . . . . : QSYSOPR
Library . . . . . . . . . . : QSYS

```

-----Active Switched Controllers-----

```

TRBLDAS41 TRBLDAS45 TRBLDAS51 TRBLDALT TRVMLAB TRBLDAS42
TRBLDAS37

```

-Source Service Access Points- -Source Service Access Points-

SSAP	Maximum Frame	Type	SSAP	Maximum Frame	Type
04	*MAXFRAME	*SNA	AA	*MAXFRAME	*NONSNA
12	*MAXFRAME	*NONSNA	C8	*MAXFRAME	*HPR

Link speed	: LINKSPEED	16M
Cost/connect time	: COSTCNN	0
Cost/byte	: COSTBYTE	0
Security for line	: SECURITY	*NONSECURE
Propagation delay	: PRPDLY	*LAN
User-defined 1	: USRDFN1	128
User-defined 2	: USRDFN2	128
User-defined 3	: USRDFN3	128
Autocreate controller	: AUTOCRTCTL	*NO
Recovery limits	: CMNRCYLMT	
Count limit	:	2
Time interval	:	5
Functional address	:	FCNADR
Line description	: LIND	TRLANAS44
Option	: OPTION	*ALL
Category of line	:	*TRLAN

Advanced Program-to-Program (APPC) Controller Descriptions

To create an APPC controller description for your AS/400 PSF Direct configuration, enter the following on your AS/400 Operating System:

```
CRTCTLAPPC CTLD(controller_name) LINKTYPE(*LAN)
SWTLINLST(line_name) RMTCPNAME(nt_cp_name) RMTNETID
(nt_id)(EXCHID(block_id+xid) ADPTADR(pc_nic_address0)
```

This command example will create output similar to the following:

```
5769SS1 V4R4M0 990521
```

```
Controller description . . . . . : CTLD      NTTEST
Option . . . . . : OPTION  *ALL
Category of controller . . . . . :          *APPC
Link type . . . . . : LINKTYPE *LAN
Online at IPL . . . . . : ONLINE  *NO
Active switched line . . . . . :          TRLANAS44
Character code . . . . . : CODE    *EBCDIC
Maximum frame size . . . . . : MAXFRAME 16393
Current maximum frame size .. . :          3808
Remote network identifier . . . . : RMTNETID USIBMBQ
Remote control point . . . . . : RMTCPNAME NT2
Exchange identifier . . . . . : EXCHID  05DC021C
Initial connection .. . . . : INLCNN  *DIAL
Dial initiation . . . . . : DIALINIT *LINKTYPE
Switched disconnect . . . . . : SWTDSC  *YES
Data link role . . . . . : ROLE    *NEG
LAN remote adapter address .. . : ADPTADR 400059550067
LAN DSAP . . . . . : DSAP    04
LAN SSAP . . . . . : SSAP    04
```

```

Autocreate device . . . . . : AUTOCRTDEV*ALL
System job . . . . . : QCMNARB03
Message queue . . . . . : MSGQ *SYSVAL
Current message queue . . . . . : QSYSOPR
Library . . . . . : QSYS
Text . . . . . : TEXT *BLANK
Switched line list . . . . . : SWTLINLST

```

-----Switched Lines-----

```

TRLANAS44 Attached devices . . . . . : DEV

```

-----Attached Devices-----

```

APPN-capable . . . . . : APPN *YES
APPN CP session support . . . . . : CPSSN *YES
APPN/HPR capable . . . . . : HPR
path switching . . . . . : HPRPHTSWT *NO
Branch extender role . . . . . : BEXROLE *NETNODE
Remote APPN node type . . . . . : NODETYPE *ENDNODE
APPN transmission group number : TMSGPNBR 1
APPN minimum switched status . : MINSWTSTS *VRYONPND
Autodelete device . . . . . : AUTODLTDEV1440
User-defined 1 . . . . . : USRDFN1 *LIND
User-defined 2 . . . . . : USRDFN2 *LIND
User-defined 3 . . . . . : USRDFN3 *LIND
Model controller description . : MDLCTL *NO

```

```

Control owner . . . . . : CTLOWN    *USER
Disconnect timer . . . . . : DSCTMR
Minimum connect timer . . . . . :          170
Disconnection delay timer . . . . . :          30
LAN frame retry . . . . . : LANFRMRTY 10
LAN connection retry . . . . . : LANCNNRTY 10

```

Display Controller Description

```

Controller description . . . . . : CTLD      NTTEST
Option . . . . . : OPTION    *ALL
Category of controller . . . . . :          *APPC
LAN response timer . . . . . : LANRSPTMR 30
LAN connection timer . . . . . : LANCNNTMR 70
LAN acknowledgement timer . . . . . : LANACKTMR 1
LAN inactivity timer . . . . . : LANINACTMR100
LAN acknowledgement frequency . : LANACKFRQ 7
LAN max outstanding frames . . : LANMAXOUT 7
LAN access priority . . . . . : LANACCPTY 0
LAN window step . . . . . : LANWDWSTP *NONE
Recovery limits . . . . . : CMNRCYLMT
Count limit . . . . . :          2
Time interval . . . . . :          5

```

Host Printer Device Description

To create a host printer definition for your AS/400 PSF Direct configuration, enter the following on your AS/400 Operating System:

```
CRTDEVPRT DEVD(prtr_devd) DEVCLS(*RMT) TYPE(*IPDS) MODEL(0)
AFP(*YES) AFPATTACH(*APPC) FONT(font_id)
RMTLOCNAME(pc_network_name.pc_luname)
```

This command example will create output similar to the following:

```
5769SS1 V4R4M0 990521
```

```
Device description . . . . . : DEVD          NTTEST
Option . . . . . : OPTION          *ALL
Category of device . . . . . :              *PRT
Automatically created . . . . . :          NO
Device class . . . . . : DEVCLS       *RMT
Device type . . . . . : TYPE          *IPDS
Device model . . . . . : MODEL        0
Advanced function printing .. . : AFP          *YES
AFP attachment . . . . . : AFPATTACH  *APPC
Online at IPL . . . . . : ONLINE      *NO
Font . . . . . :
FONT Identifier . . . . . :              011
Point size . . . . . :                *NONE
Form feed . . . . . : FORMFEED       *AUTOCUT
Separator drawer .. . . . : SEPDRAWER *FILE
Separator program . . . . . : SEPPGM   *NONE
Library . . . . . :
Printer error message . . . . . : PRTERMSG *INQ
Message queue . . . . . : MSGQ        QSYSOPR
```

```

Library . . . . . : *LIBL
Current message queue . . . . . : QSYSOPR
Library . . . . . : QSYS
Image configuration . . . . . : IMGCFG *NONE
Maximum pending requests . . . . . : MAXPDRQS 6
Print while converting . . . . . : PRTCVT *YES
Form definition . . . . . : FORMDF F1C10110
Library . . . . . : *LIBL
Character identifier . . . . . : CHRID *SYSVAL
Remote location . . . . . : RMTLOCNAME AS4TEST
Name or address . . . . . : USIBMBQ.AS4TES
T
Local location . . . . . : LCLLOCNAME *NETATR
Mode . . . . . : MODE QSPWTR
User-defined object . . . . . : USRDFNOBJ *NONE
Object type . . . . . : *NONE
Data transform program . . . . . : USRDTATFM *NONE
User-defined driver program . . . . . : USRDRVPGM *NONE
Dependent location name . . . . . : DEPLOCNAME *NONE
Allocated to:
Job name . . . . . : NTTEST
User . . . . . : QSPLJOB
Number . . . . . : 055699
Text . . . . . : TEXT InfoPrint/NT
User-defined options. . . . . : USRDFNOPT

```

Accessing the Communications Server for NT Profiles

Use the following procedure to access the IBM SecureWay Communications Server for NT applications described in the What is Communications Server for NT? topic.

Note that the following presumes you have dragged the icons for **SNA Node Configuration** and **SNA Node Operations** to your desktop after they were created at installation.

1. From your NT desktop view, double-click on the **SNA Node Configuration** icon that resides on your desktop:

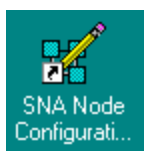

2. At the **Welcome to Communications Server Configuration!** pop-up window, select the **New** button (for a new configuration) and click on the **Next>** button.
3. Check the **Advanced** box, which causes the display to turn to grey (displayed below) and click the **Finish** button.

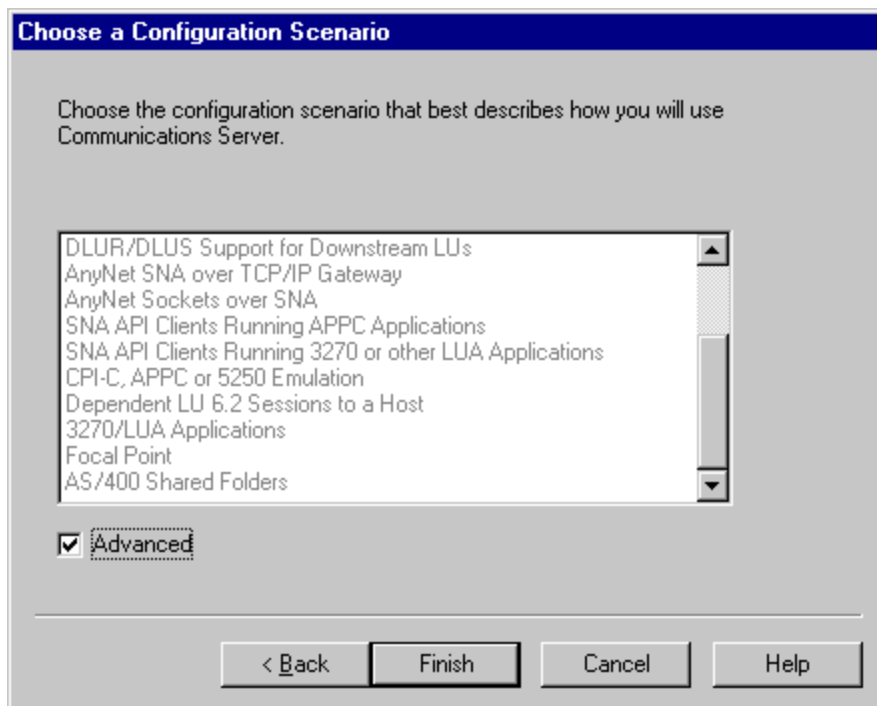

4. From the **Communications Server SNA Node Configuration** window (displayed below), you are ready to begin configuring your system for PSF Direct.

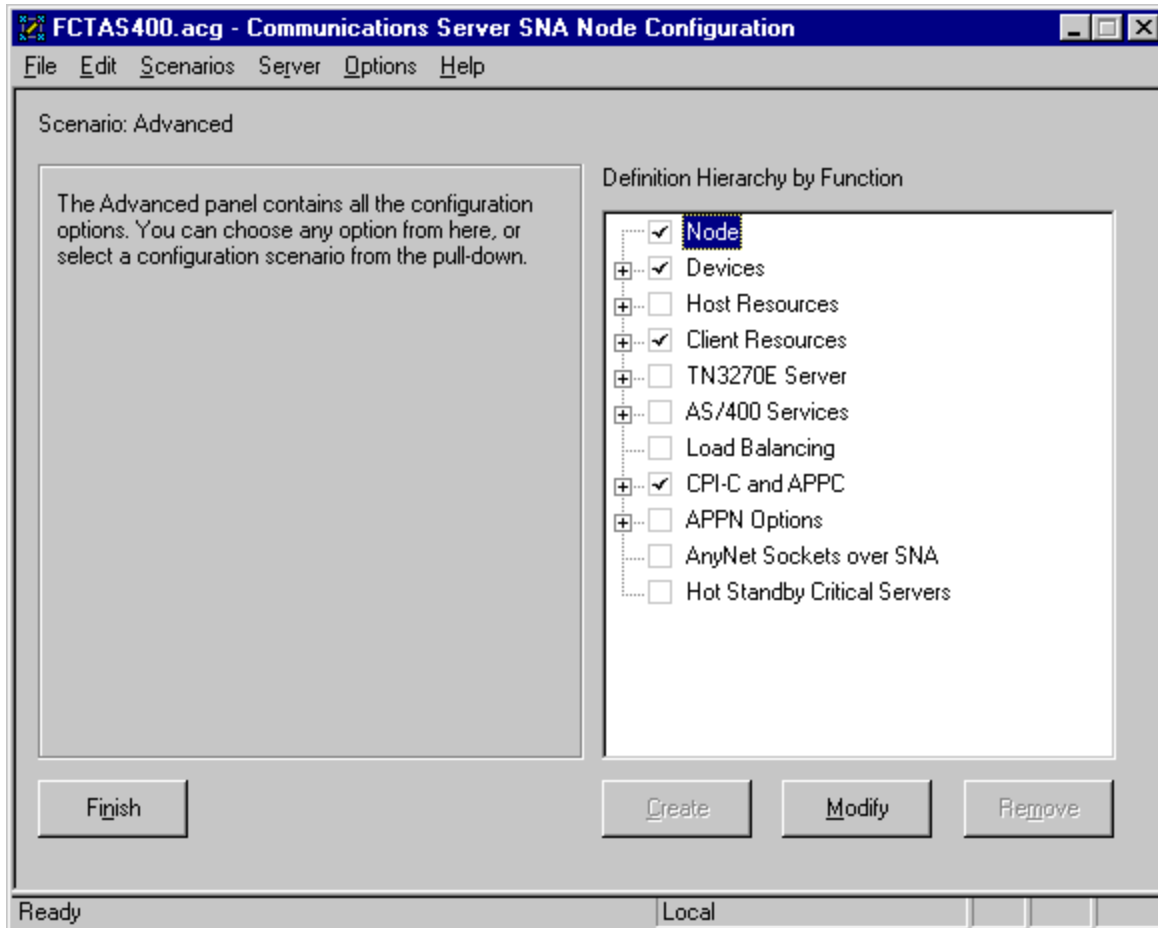

Communications Server for NT Configuration Profile Examples

From the preceding display of the **Communications Server SNA Node Configuration** window, there are eight configuration steps that you must complete. The following examples provide images with the appropriate examples filled in.

You access this panel by right-clicking on the checked **Node** box of the **Communications Server SNA Node Configuration** window (displayed below) and selecting the **Create** option.

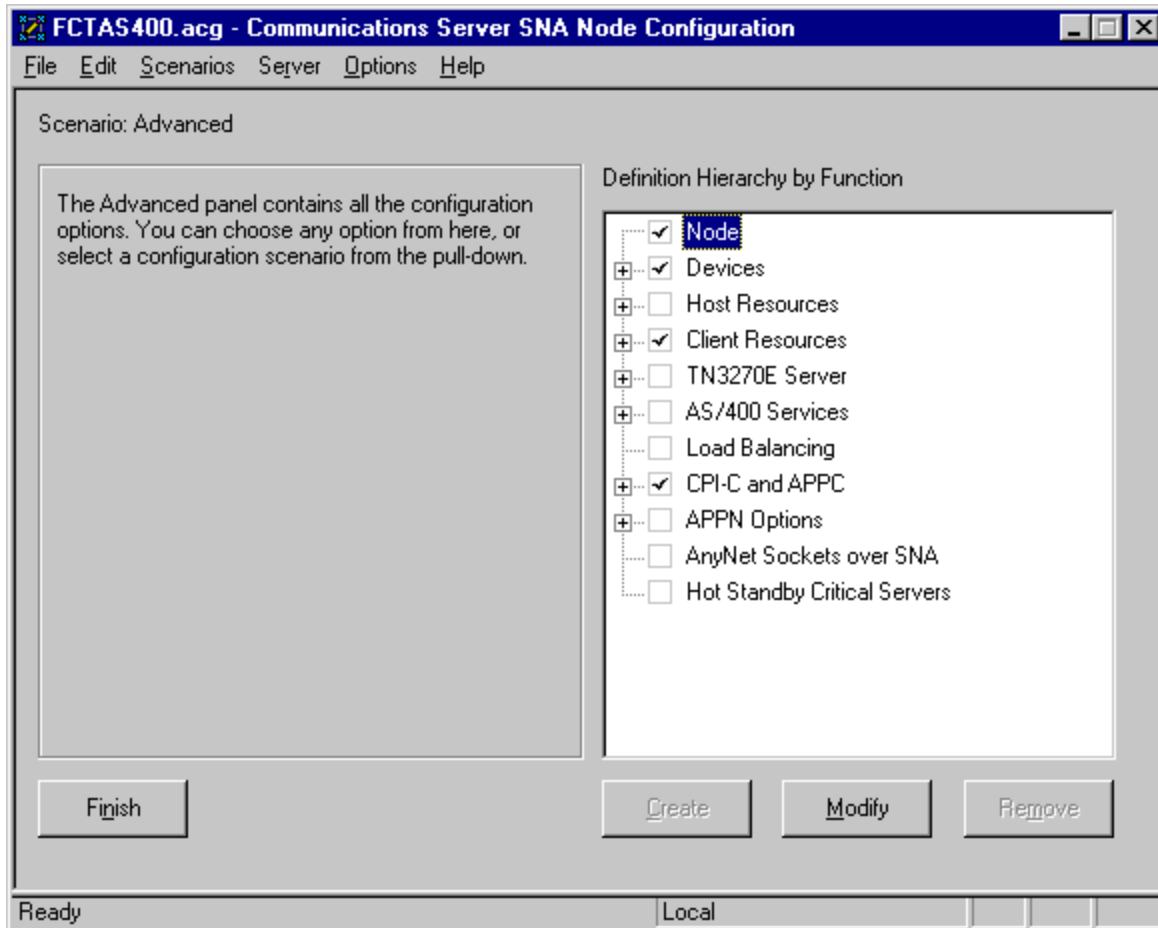

For more information about this configuration view, refer to the guidelines for [AS/400 Node setup -- the Basic options](#).

Basic Configuration

The image shows a Windows-style dialog box titled "Define the Node" with a close button (X) in the top right corner. The dialog has three tabs: "Basic", "Advanced", and "DLU Requester". The "Basic" tab is selected. The dialog is divided into three sections:

- Control Point (CP):** A group box containing:
 - "Fully qualified CP name:" with two text boxes containing "USIBMBQ" and "NT2", separated by a period.
 - "CP alias:" with a text box containing "NT2".
- Local Node ID:** A group box containing:
 - "Block ID:" with a text box containing "05D".
 - "Physical Unit ID:" with a text box containing "C021C".
- Node Type:** A group box containing three radio buttons:
 - End Node
 - Network Node
 - Branch Extender Node

At the bottom of the dialog are four buttons: "OK", "Cancel", "Apply", and "Help".

For more information about this configuration view, refer to the guidelines for [AS/400 Node setup -- the Advanced options](#).

Note that the **Advanced Configuration** panel takes the Communication Server for NT defaults and is shown for reference only.

Advanced Configuration

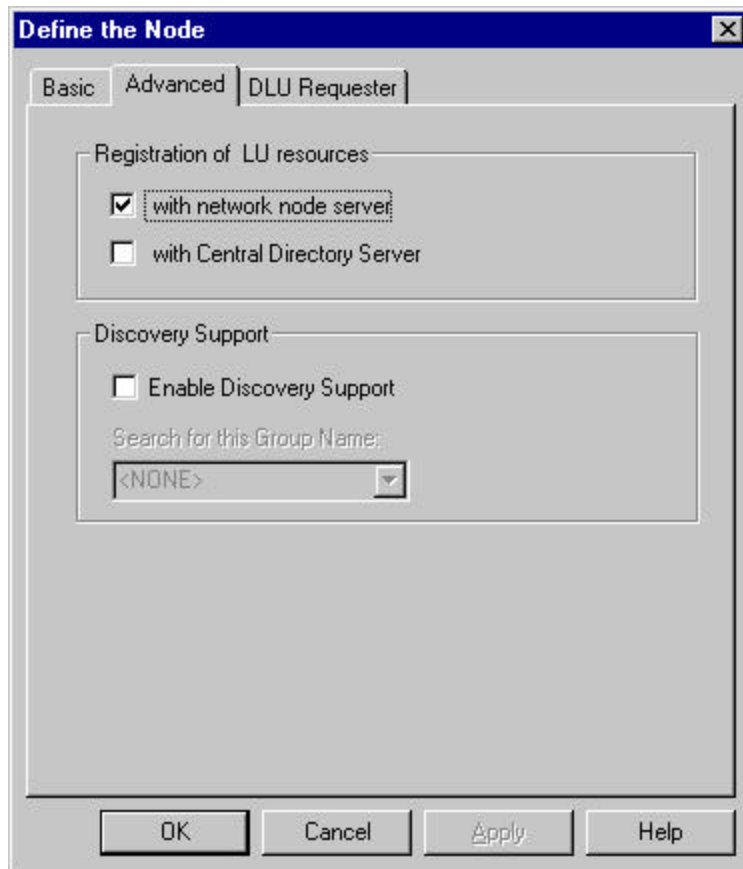

For more information about this configuration view, refer to the guidelines for [AS/400 Node setup -- the DLU requester options](#).

Note that the **DLU Requester** panel takes the Communication Server for NT defaults and is shown for reference only.

DLU Requester

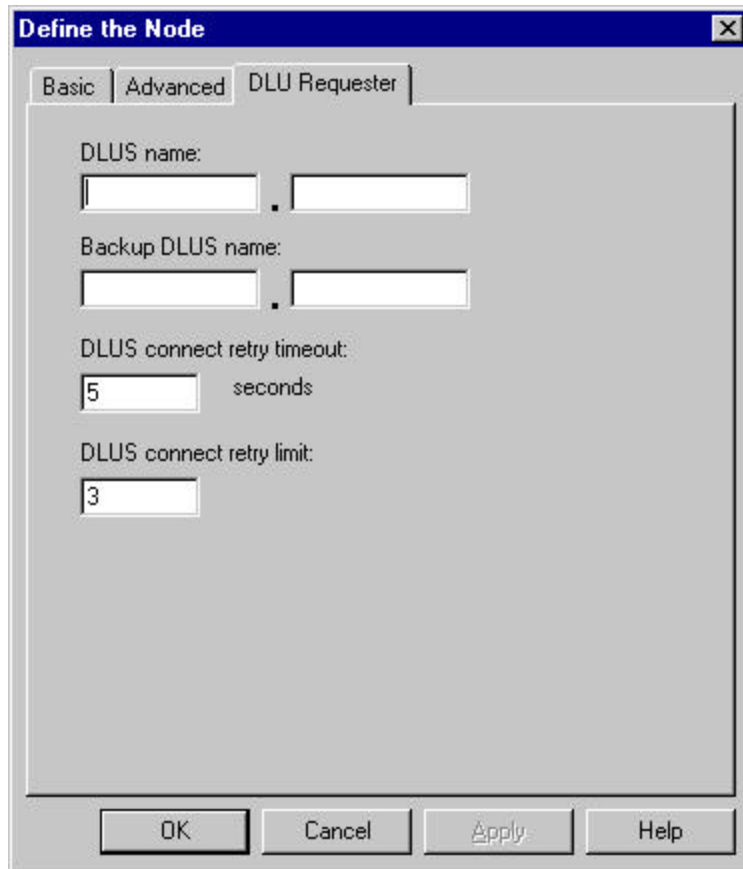

The screenshot shows a dialog box titled "Define the Node" with a close button (X) in the top right corner. The dialog has three tabs: "Basic", "Advanced", and "DLU Requester", with the "DLU Requester" tab selected. The main area contains the following fields:

- DLUS name:** Two text input boxes separated by a period (.)
- Backup DLUS name:** Two text input boxes separated by a period (.)
- DLUS connect retry timeout:** A text input box containing the number "5" followed by the text "seconds".
- DLUS connect retry limit:** A text input box containing the number "3".

At the bottom of the dialog, there are four buttons: "OK", "Cancel", "Apply", and "Help".

Single-click on the **OK** button at the bottom of the screen to save these specifications to the appropriate *.acg file.

AS/400 Device Configuration

You access these panels by right-clicking on the **Devices** box of the **Communications Server SNA Node Configuration** window (displayed below) and selecting the **Create** option.

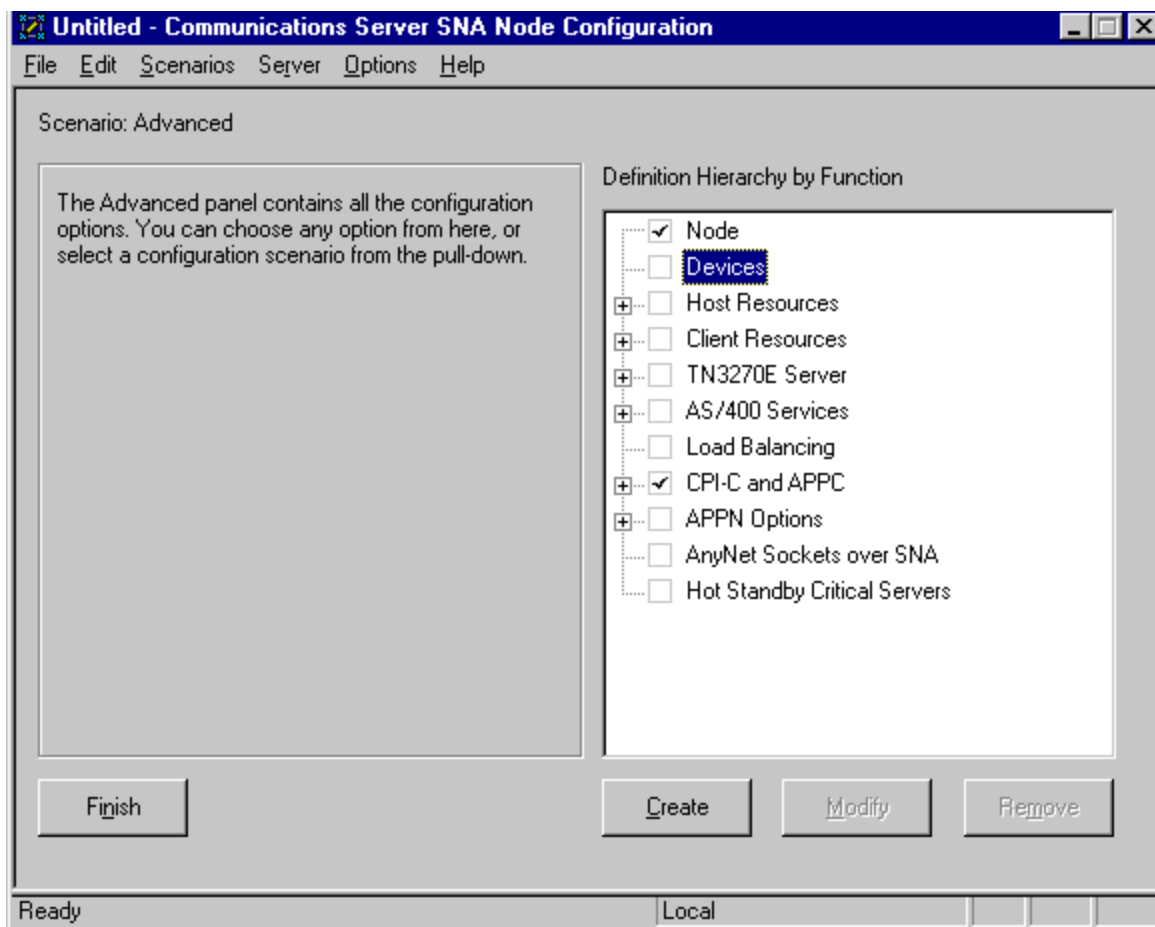

In the **Device Type** pop-up window, select LAN:

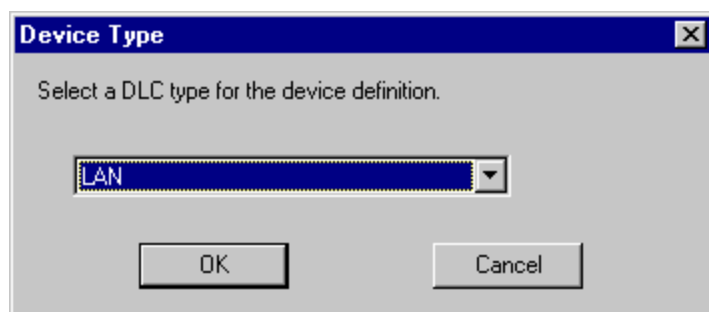

Click **OK**.

On the **Define a LAN Device** window, note that you may have more than one adapter defined at your installation. Ensure that you select the proper token-ring LAN adapter (depending upon your installation may display both token-ring and ethernet adapters).

For more information about this configuration view, refer to the guidelines for [Device Configuration -- the Basic options](#).

Basic Configuration

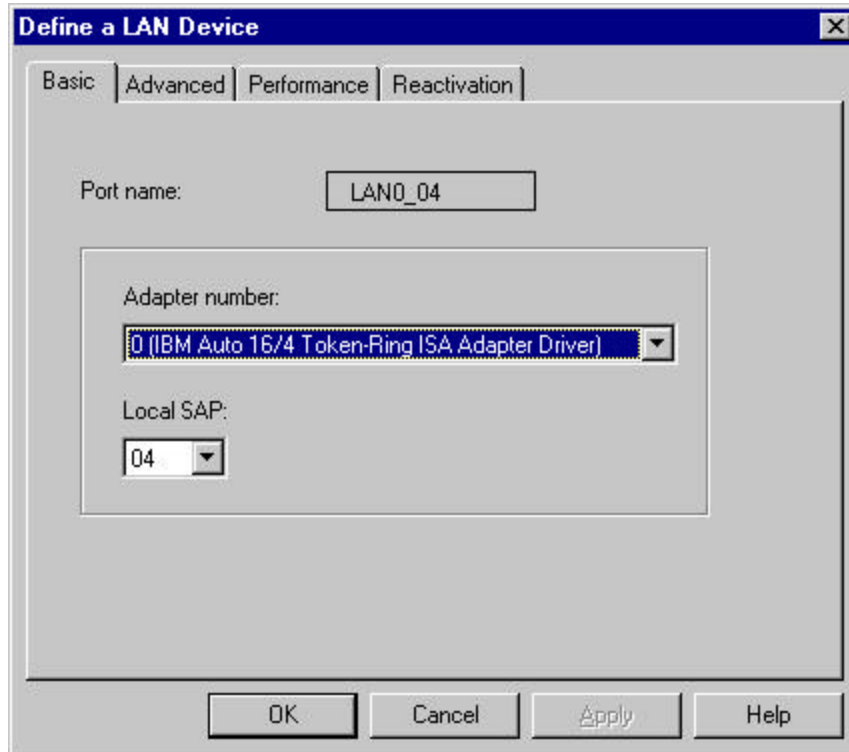

For more information about this configuration view, refer to the guidelines for [Device Configuration -- the Advanced options](#).

Advanced Configuration

The image shows a screenshot of a Windows-style dialog box titled "Define a LAN Device". The dialog has four tabs: "Basic", "Advanced", "Performance", and "Reactivation". The "Advanced" tab is currently selected. The dialog contains the following configuration options:

- XID retry interval: 8 seconds (dropdown menu)
- XID retry limit: 5 (dropdown menu)
- Test retry interval: 8 seconds (dropdown menu)
- Test retry limit: 5 (dropdown menu)
- Receive window count: 7 (dropdown menu)
- Maximum PIU size: 65535 (text input field)

At the bottom of the dialog, there are four buttons: "OK", "Cancel", "Apply", and "Help".

For more information about this configuration view, refer to the guidelines for [Device Configuration -- the Performance options](#).

Note that the **Performance Configuration** panel takes the Communication Server for NT defaults and is shown for reference only.

Performance Configuration

The image shows a screenshot of a Windows dialog box titled "Define a LAN Device". The dialog has four tabs: "Basic", "Advanced", "Performance", and "Reactivation". The "Performance" tab is selected. The dialog contains several configuration options, each with a text input field and a unit label:

Parameter	Value	Unit
Idle timeout:	30	seconds
Busy state timeout:	15	seconds
REJ response timeout:	10	seconds
Acknowledgement delay:	100	ms
POLL response timeout:	8000	ms
Acknowledgement timeout:	10000	ms
Anticipated outstanding transmits:	16	
Receive buffer count:	32	

At the bottom of the dialog, there are four buttons: "OK", "Cancel", "Apply", and "Help".

For more information about this configuration view, refer to the guidelines for [Device Configuration -- the Reactivation options](#).

Note that the **Reactivation Configuration** panel takes the Communication Server for NT defaults and is shown for reference only.

Reactivation Configuration

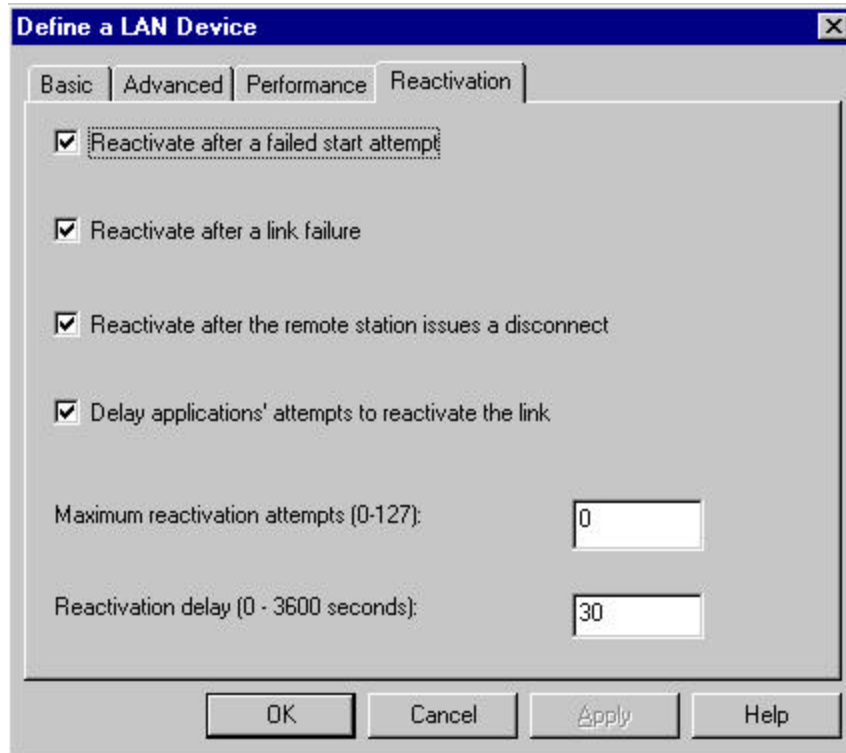

Single-click on the **OK** button at the bottom of the screen to save these specifications to the appropriate *.acg file.

SNA API Client Configuration

For more information about this example, refer to the guidelines for [Enabling SNA API Clients on your Infoprint Microsoft NT Server](#).

You access these panels by clicking the **Client Resources** box and then right-clicking on the **SNA API Clients** box (displayed below) and selecting the **Create** option.

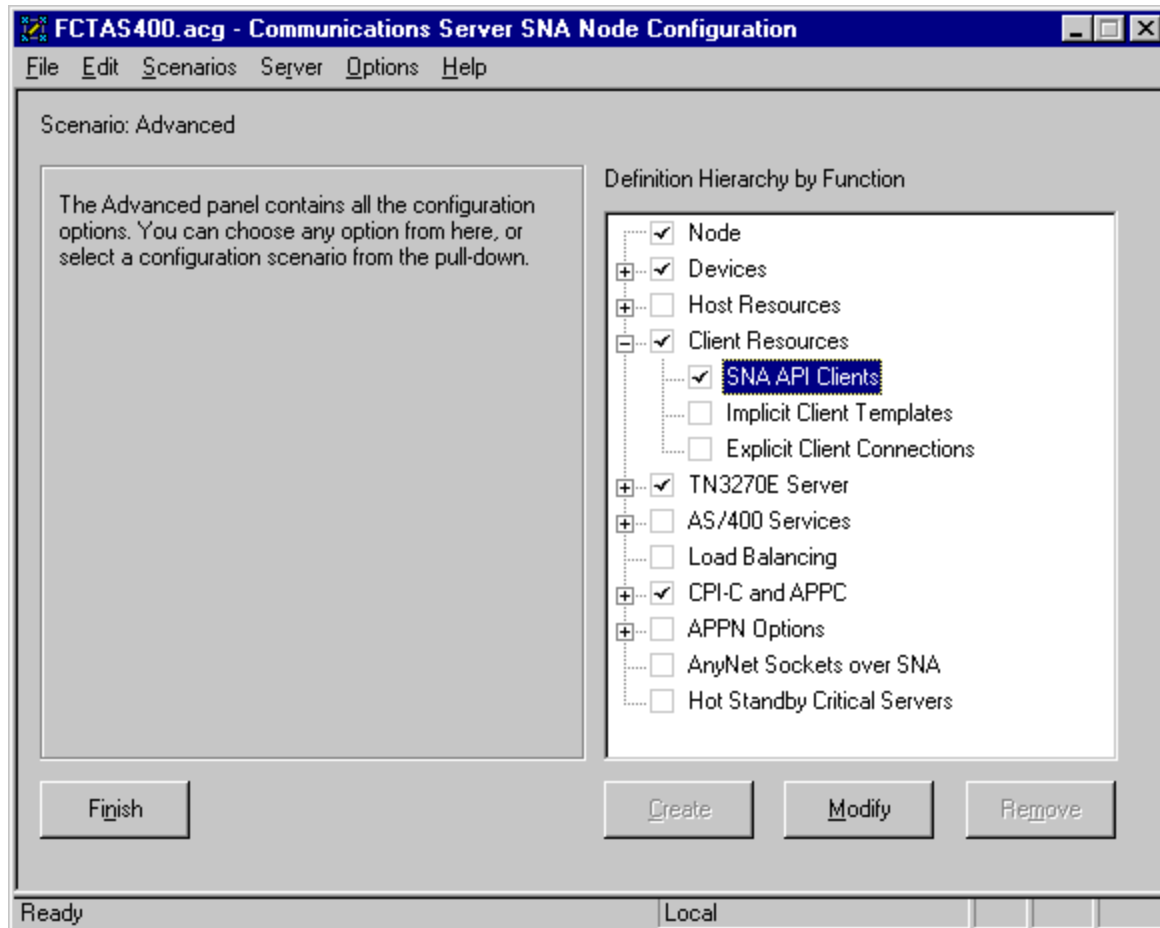

From the SNA Clients pop-up window, accept the default values by clicking **OK**.

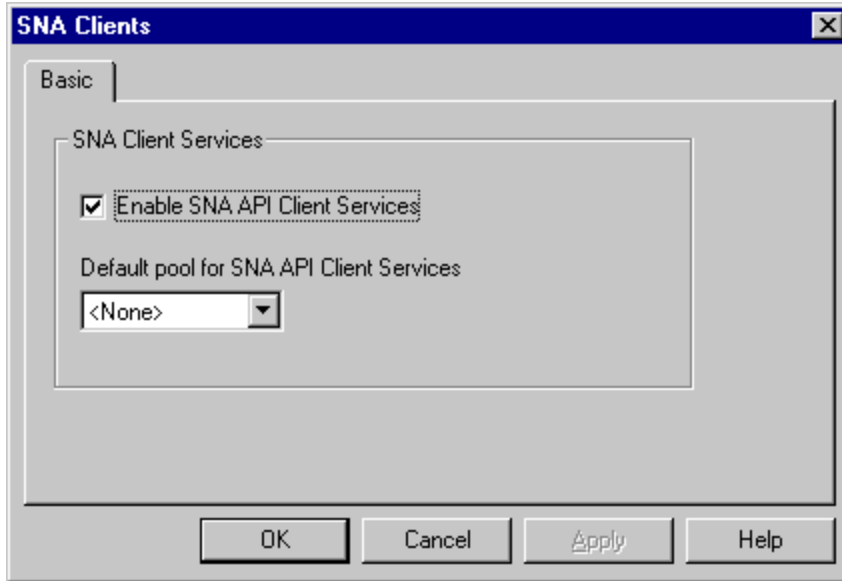

Single-click on the **OK** button at the bottom of the screen to save these specifications to the appropriate *.acg file.

AS/400 Peer Connection Configuration

You access these panels by right-clicking on the **Peer Connections** box (displayed below) and selecting the **Create** option.

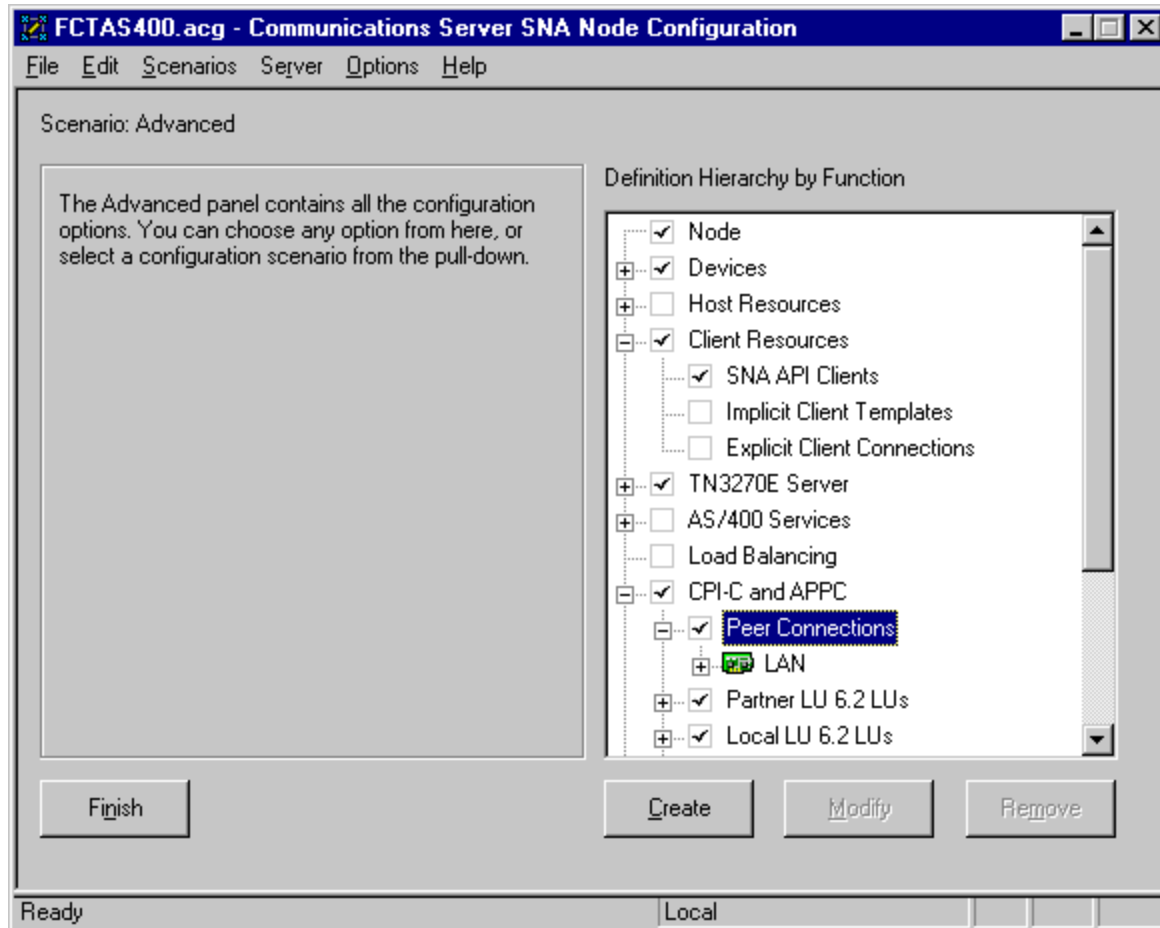

For more information about this configuration view, refer to the guidelines for [Peer Connection Configuration -- the Basic options](#).

Note that the **Link station name** field contents will vary, depending upon the number of links at your installation.

Basic Configuration

The screenshot shows a dialog box titled "Define a LAN Connection" with a close button (X) in the top right corner. The dialog has four tabs: "Basic", "Advanced", "Adjacent Node", and "Reactivation". The "Basic" tab is selected. Inside the dialog, there are several options with checkboxes:

- Activate link at start
- HPR support
- APPN support
- Auto-activate support
- Link to preferred NN server
- Solicit SSCP sessions

Below these options is a text field labeled "PU name:" containing the text "LINK0001".

- Use PU name as CP name
- Encryption mandatory
- Compression requested
- Branch extender connection

At the bottom, there is a section for "Local Node ID" with two sub-fields:

- Block ID: 05D
- Physical Unit ID: C021C

At the very bottom of the dialog are four buttons: "OK", "Cancel", "Apply", and "Help".

For more information about this configuration view, refer to the guidelines for [Peer Connection Configuration -- the Advanced options](#).

Advanced Configuration

The screenshot shows a dialog box titled "Define a LAN Connection" with a close button (X) in the top right corner. The dialog has four tabs: "Basic", "Advanced", "Adjacent Node", and "Reactivation". The "Advanced" tab is selected. The "Advanced" tab contains the following options:

- Activate link at start
- HPR support
- APPN support
- Auto-activate support
- Link to preferred NN server
- Solicit SSCP sessions
- PU name:
- Use PU name as CP name
- Encryption mandatory
- Compression requested
- Branch extender connection

Below these options is a section for "Local Node ID" with two sub-fields:

- Block ID:
- Physical Unit ID:

At the bottom of the dialog are four buttons: "OK", "Cancel", "Apply", and "Help".

For the Adjacent Node Configuration, take the Communications server defaults.

Adjacent Node Configuration

The image shows a Windows-style dialog box titled "Define a LAN Connection" with a close button (X) in the top right corner. The dialog has four tabs: "Basic", "Advanced", "Adjacent Node", and "Reactivation". The "Adjacent Node" tab is currently selected. The main area of the dialog contains the following fields:

- Adjacent CP name:** Two text input boxes separated by a period (.), both of which are empty.
- Adjacent CP type:** A dropdown menu with "Learn" selected.
- TG number:** A dropdown menu with "0" selected.
- Adjacent node ID:** A container box containing two sub-fields:
 - Block ID:** A text input box containing "000".
 - Physical Unit ID:** A text input box containing "00000".

At the bottom of the dialog, there are four buttons: "OK", "Cancel", "Apply", and "Help".

For the Reactivation Configuration, take the Communications server defaults.

Reactivation Configuration

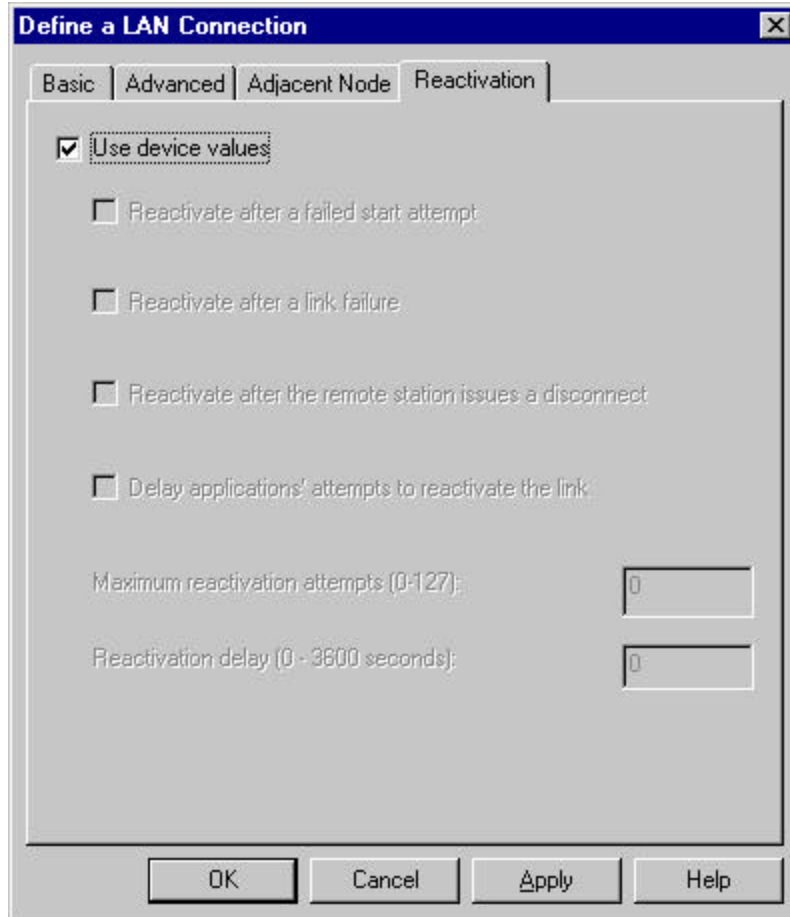

The screenshot shows a dialog box titled "Define a LAN Connection" with a close button (X) in the top right corner. The dialog has four tabs: "Basic", "Advanced", "Adjacent Node", and "Reactivation", with "Reactivation" currently selected. The "Reactivation" tab contains the following options:

- Use device values
- Reactivate after a failed start attempt
- Reactivate after a link failure
- Reactivate after the remote station issues a disconnect
- Delay applications' attempts to reactivate the link

Below these options are two input fields:

- Maximum reactivation attempts (0-127):
- Reactivation delay (0 - 3600 seconds):

At the bottom of the dialog are four buttons: "OK", "Cancel", "Apply", and "Help".

Note that after selecting the **OK** button, a pop-up window appears asking "Do you want to automatically route all applications over this connection?" You must reply yes before the configuration is accepted.

Single-click on the **OK** button at the bottom of the screen to save these specifications to the appropriate *.acg file.

AS/400 Partner LU 6.2 Configuration

You access these panels by right-clicking on the **Partner LU 6.2 LUs** box (displayed below) and selecting the **Create** option.

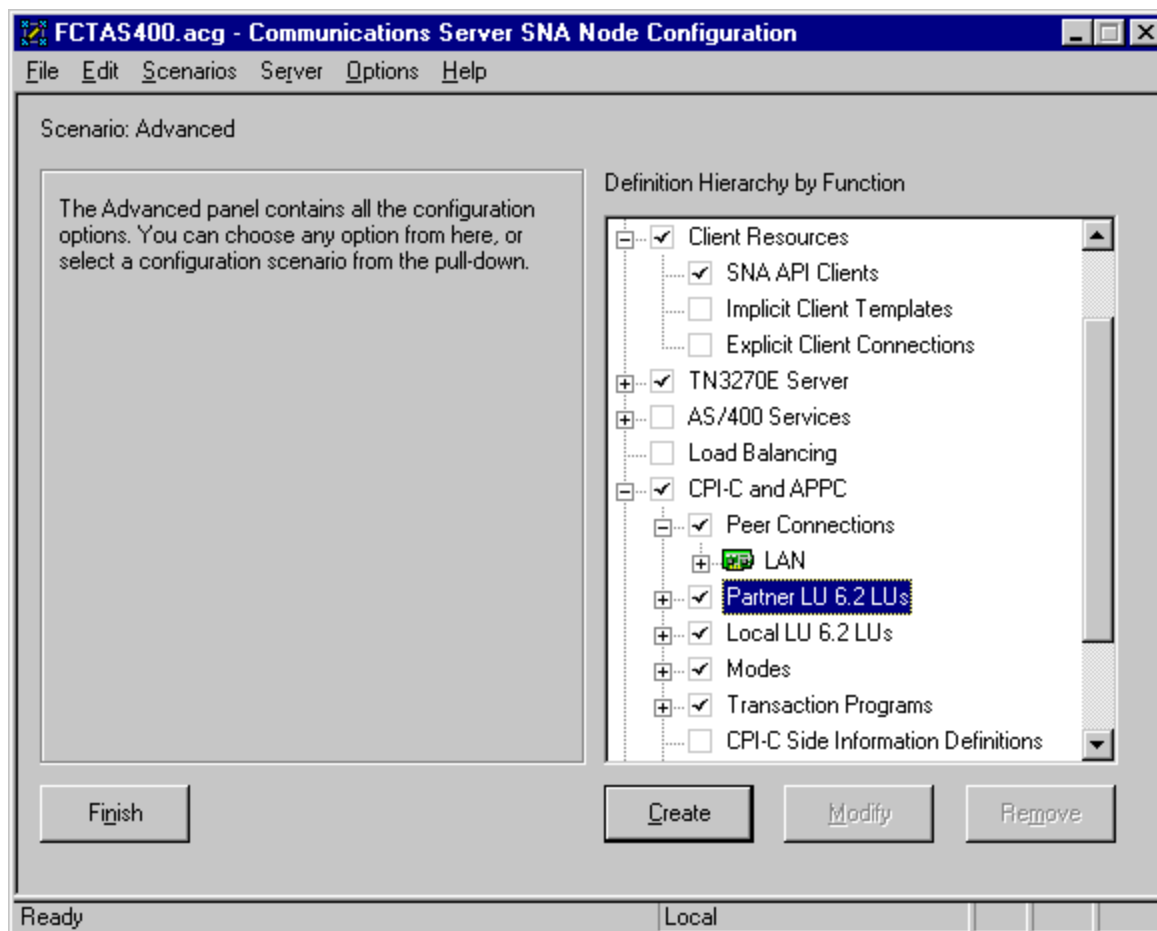

For more information about this configuration view, refer to the guidelines for [Partner LU 6.2 Configuration -- the Basic options](#).

Note that neither panel takes the Communication Server for NT defaults.

Basic Configuration

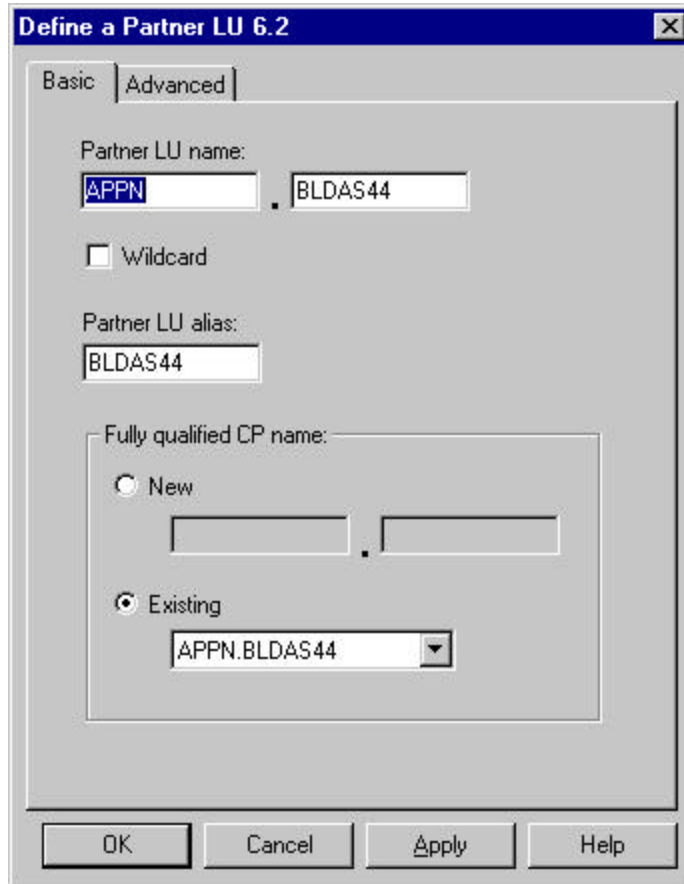

The image shows a Windows-style dialog box titled "Define a Partner LU 6.2". It has two tabs: "Basic" (selected) and "Advanced". The "Basic" tab contains the following fields and options:

- Partner LU name:** Two text boxes. The first contains "APPN" and the second contains "BLDAS44".
- Wildcard**
- Partner LU alias:** A text box containing "BLDAS44".
- Fully qualified CP name:** A section with two radio buttons:
 - New**: Below this are two empty text boxes separated by a period.
 - Existing**: Below this is a dropdown menu showing "APPN.BLDAS44".

At the bottom of the dialog are four buttons: "OK", "Cancel", "Apply", and "Help".

For more information about this configuration view, refer to the guidelines for [Partner LU 6.2 Configuration -- the Advanced options](#).

Advanced Configuration

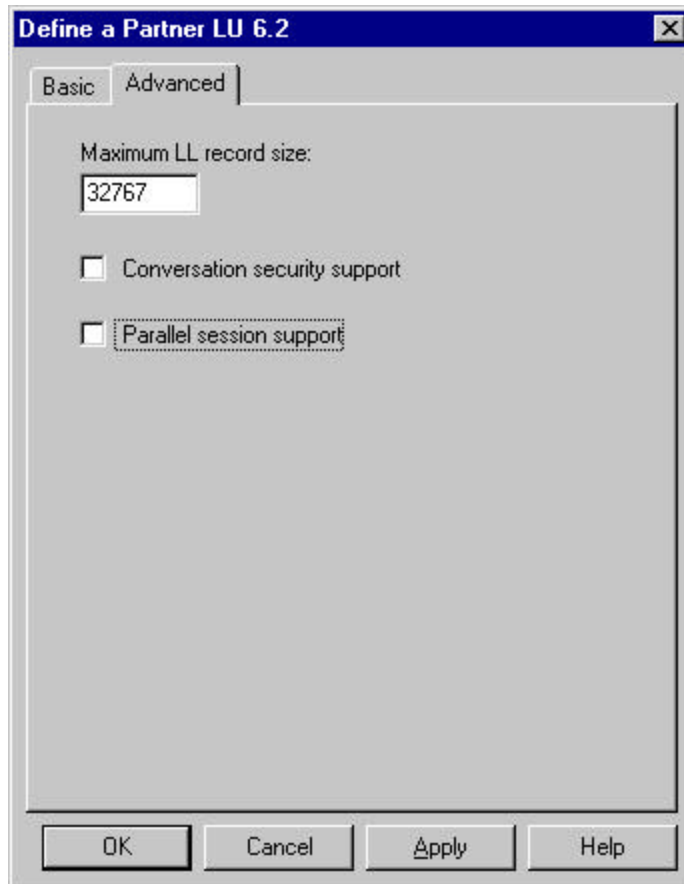

Single-click on the **OK** button at the bottom of the screen to save these specifications to the appropriate *.acg file.

AS/400 Local LU 6.2 Configuration

You access these panels by right-clicking on the **Local LU 6.2 LUs** box (displayed below) and selecting the **Create** option.

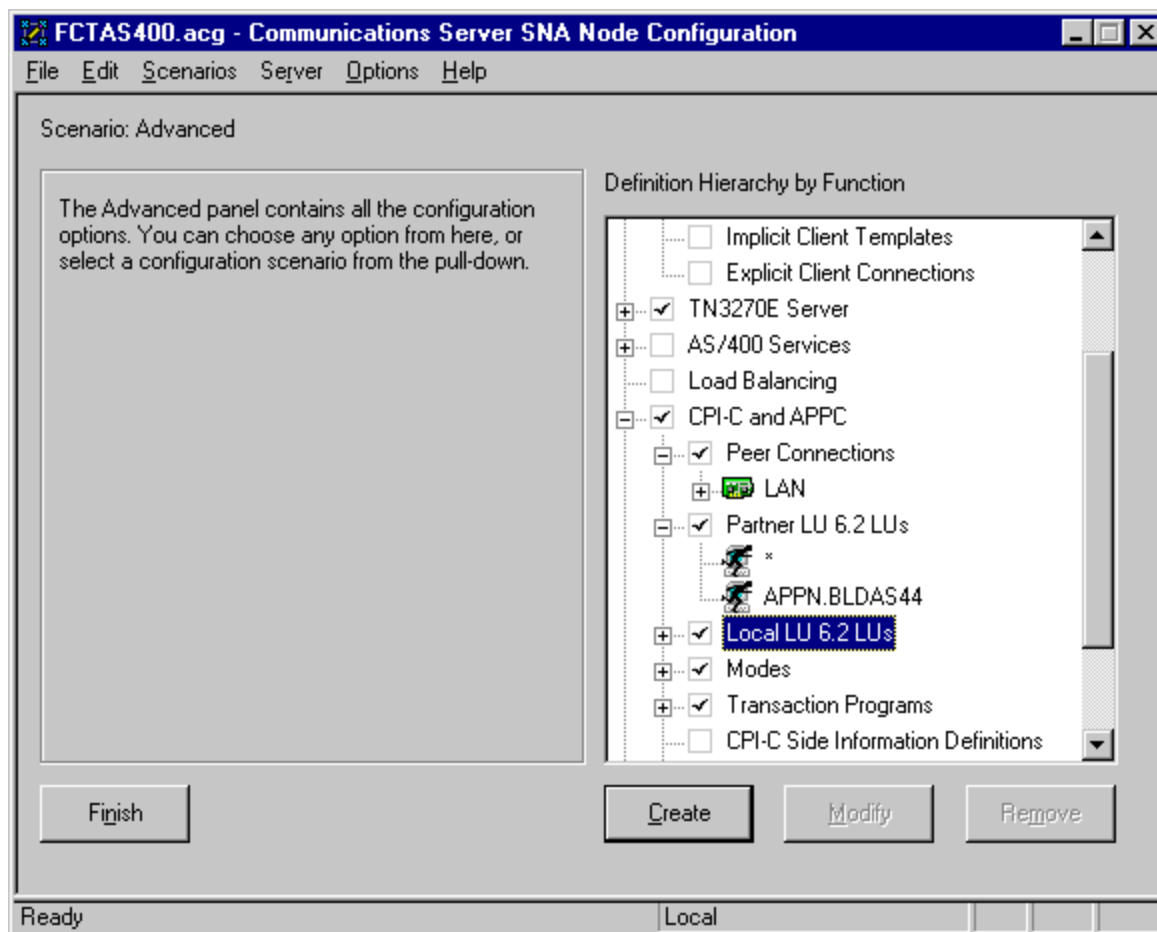

For more information about this configuration view, refer to the guidelines for [Local LU 6.2 Configuration -- the Basic options](#). Note that neither panel takes the Communication Server for NT defaults.

If you are configuring a Dependent LU, these panels cannot be used. If you require Dependent LUs, see [Decide whether to Define a Dependent or an Independent LU](#).

Basic Configuration

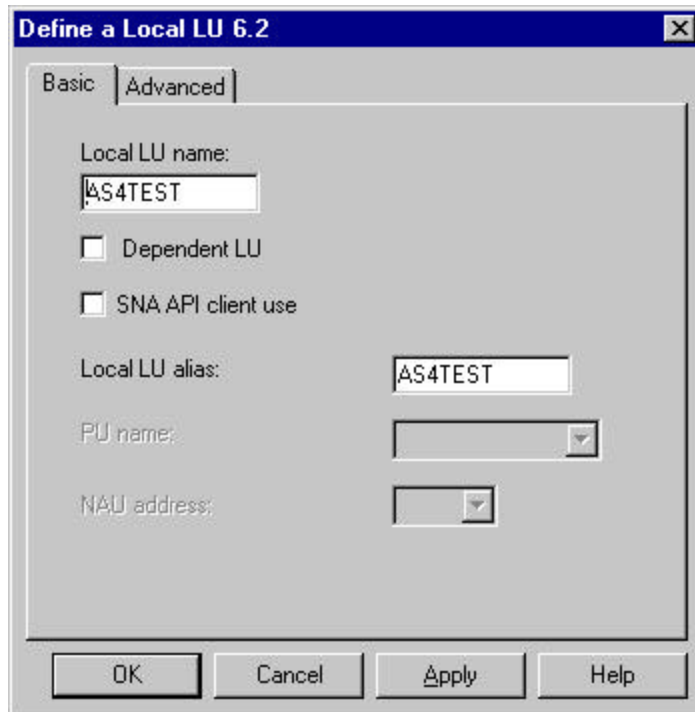

The image shows a Windows-style dialog box titled "Define a Local LU 6.2". It has two tabs: "Basic" (selected) and "Advanced". The "Basic" tab contains the following fields and options:

- Local LU name: AS4TEST
- Dependent LU
- SNA API client use
- Local LU alias: AS4TEST
- PU name: [Empty dropdown menu]
- NAU address: [Empty dropdown menu]

At the bottom of the dialog box are four buttons: "OK", "Cancel", "Apply", and "Help".

For more information about this configuration view, refer to the guidelines for [Local LU 6.2 Configuration -- the Advanced options](#).

Note: The application program only supports 1 LU session at a time, but the SNA session can support more.

Advanced Configuration

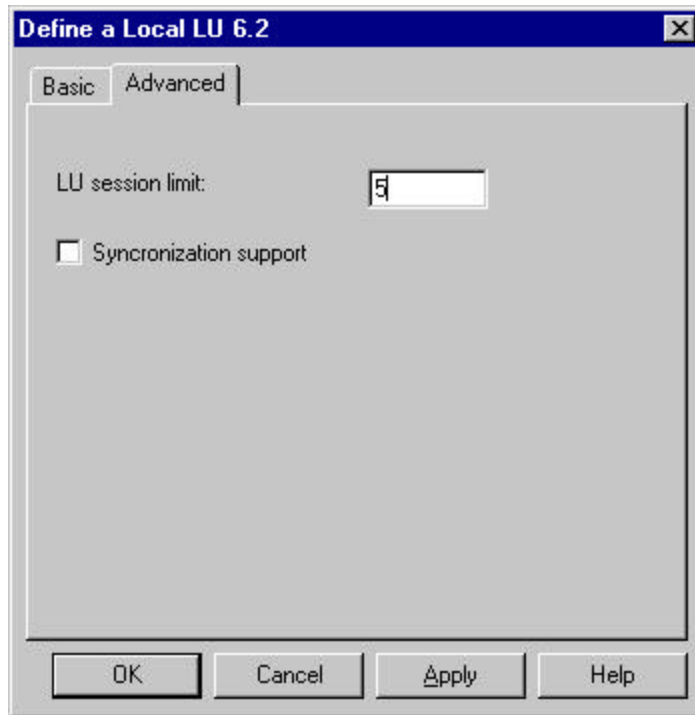

Single-click on the **OK** button at the bottom of the screen to save these specifications to the appropriate *.acg file.

AS/400 Mode Configuration

You access these panels by right-clicking on the **Modes** box (displayed below) and selecting the **Create** option.

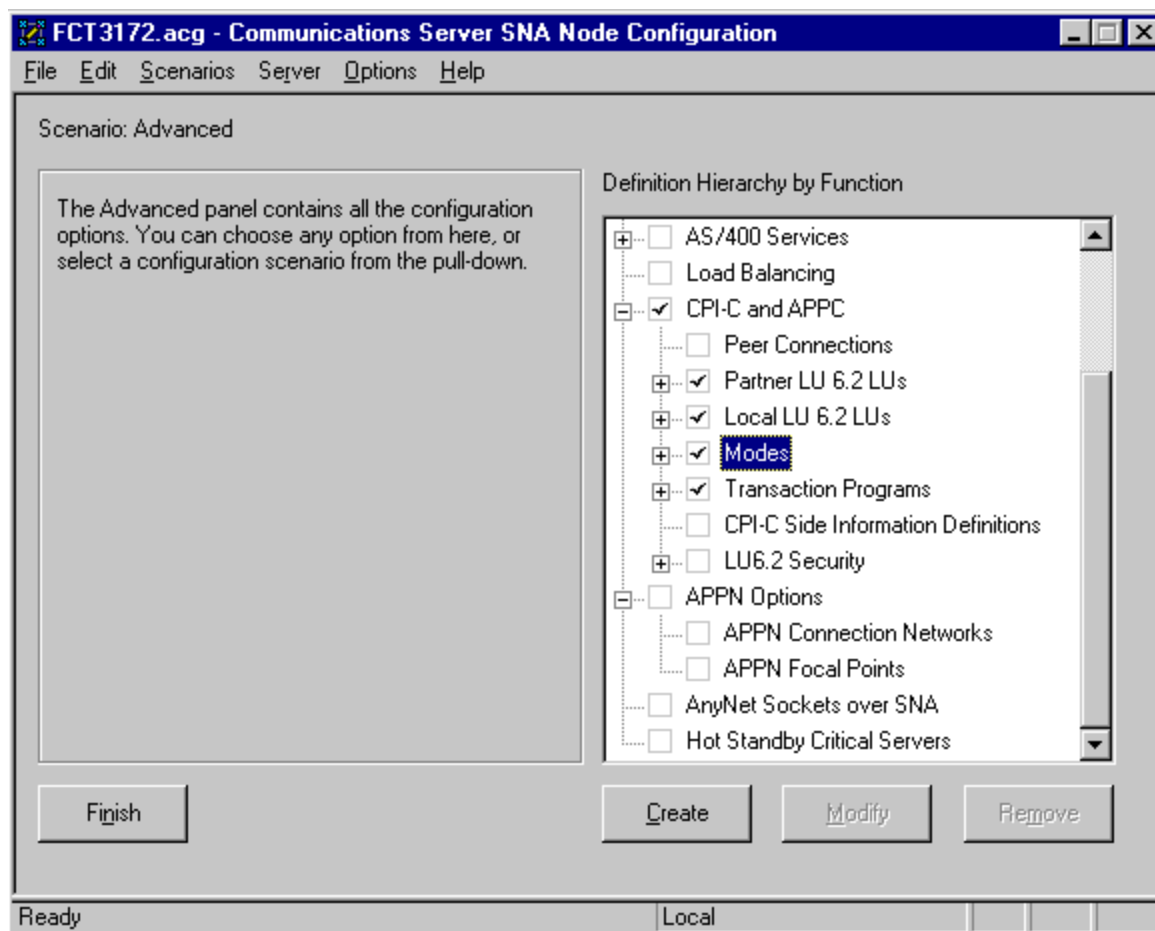

For more information about this configuration view, refer to the guidelines for [Configuring Modes -- the Basic options](#).

Basic Configuration

The image shows a dialog box titled "Define a Mode" with a close button (X) in the top right corner. The dialog has two tabs: "Basic" (selected) and "Advanced". Inside the "Basic" tab, there are three input fields:

- Mode name: QSPWTR
- PLU mode session limit: 8192
- Minimum contention winner sessions: 4096

At the bottom of the dialog, there are four buttons: "OK", "Cancel", "Apply", and "Help".

For more information about this configuration view, refer to the guidelines for [Configuring Modes -- the Advanced options](#).

Note that if the default Maximum RU size displayed below does not work, you might have to change this field to '1024'.

Advanced Configuration

The screenshot shows a dialog box titled "Define a Mode" with a close button (X) in the top right corner. It has two tabs: "Basic" and "Advanced", with "Advanced" selected. The dialog contains the following fields and controls:

- Maximum negotiable session limit: 8192
- Receive pacing window size: 1
- Auto activate sessions: 0
- Class of Service name: #CONNECT (dropdown menu)
- Use default RU size
 - Maximum RU size: 4096
- Encryption support
- Compression support
 - Maximum compression level for outbound data: <NONE> (dropdown menu)
 - Maximum compression level for inbound data: <NONE> (dropdown menu)

At the bottom of the dialog are four buttons: OK, Cancel, Apply, and Help.

Single-click on the **OK** button at the bottom of the screen to save these specifications to the appropriate *.acg file.

AS/400 Transaction Program Configuration

You access these panels by right-clicking on the **Transaction Programs** box (displayed below) and selecting the **Create** option.

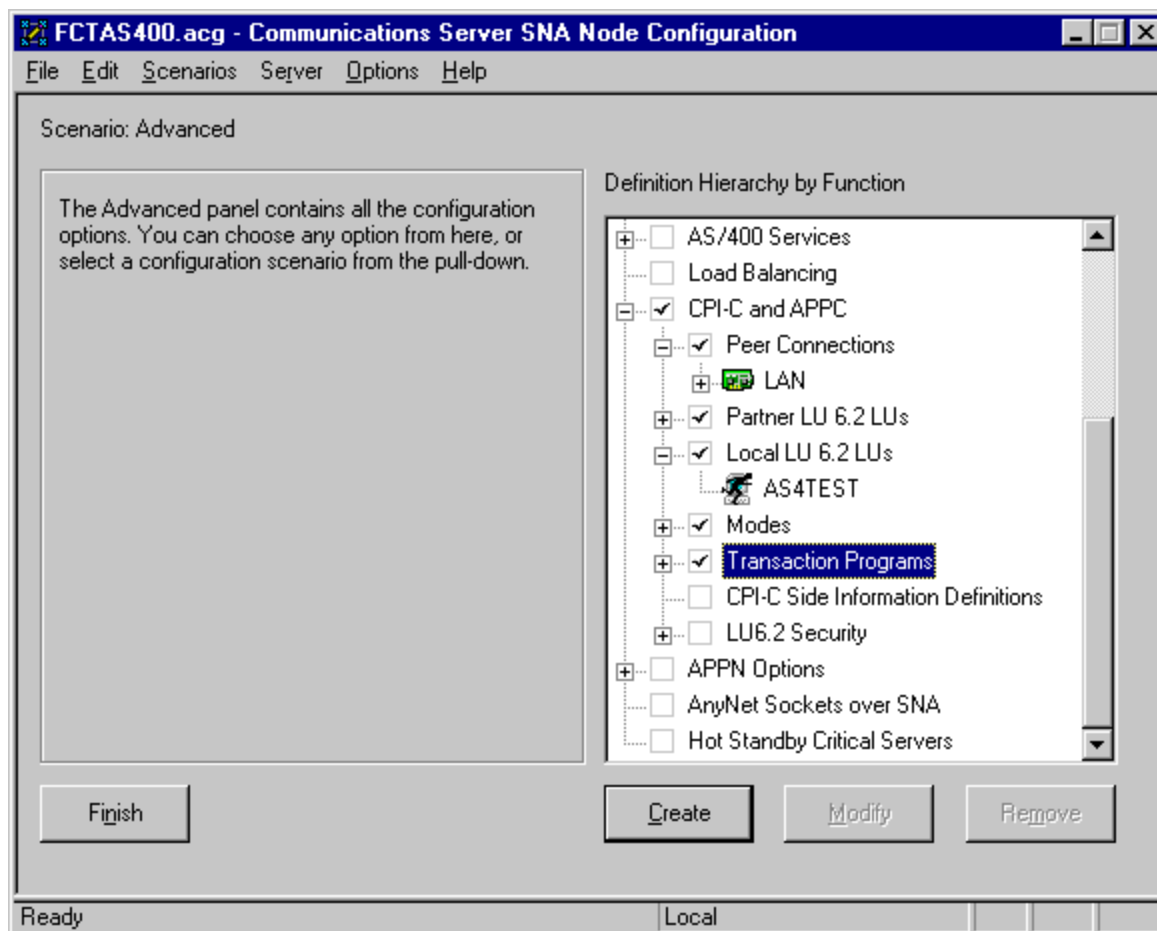

For more information about this configuration view, refer to the guidelines for [Transaction Program Configuration -- the Basic options](#).

Basic Configuration

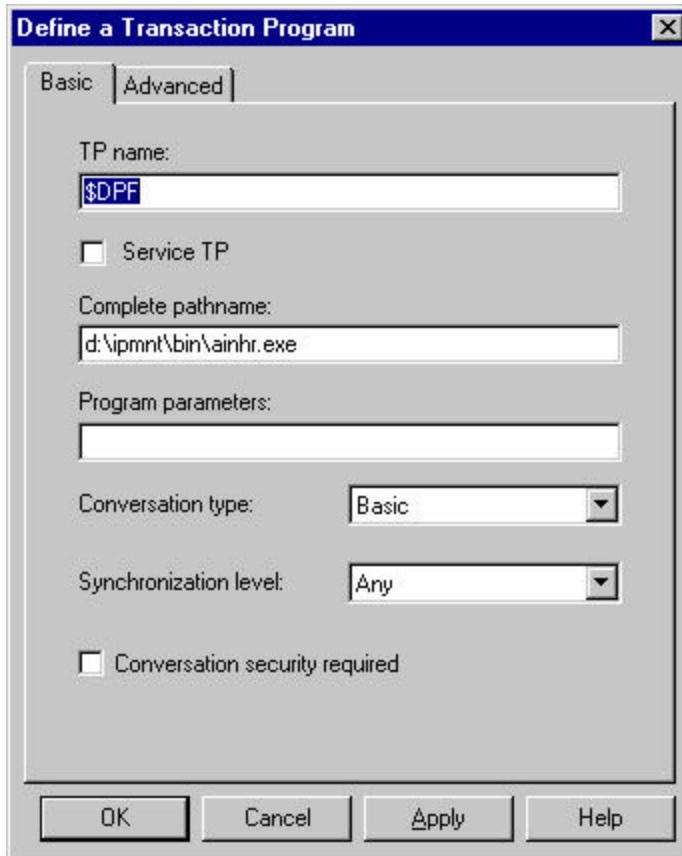

The image shows a Windows-style dialog box titled "Define a Transaction Program". It has two tabs: "Basic" (selected) and "Advanced". The "Basic" tab contains the following fields and options:

- TP name: A text box containing "\$DPF".
- Service TP
- Complete pathname: A text box containing "d:\ipmnt\bin\ainhr.exe".
- Program parameters: An empty text box.
- Conversation type: A dropdown menu set to "Basic".
- Synchronization level: A dropdown menu set to "Any".
- Conversation security required

At the bottom of the dialog box are four buttons: "OK", "Cancel", "Apply", and "Help".

For more information about this configuration view, refer to the guidelines for [Transaction Program Configuration -- the Advanced options](#).

Advanced Configuration

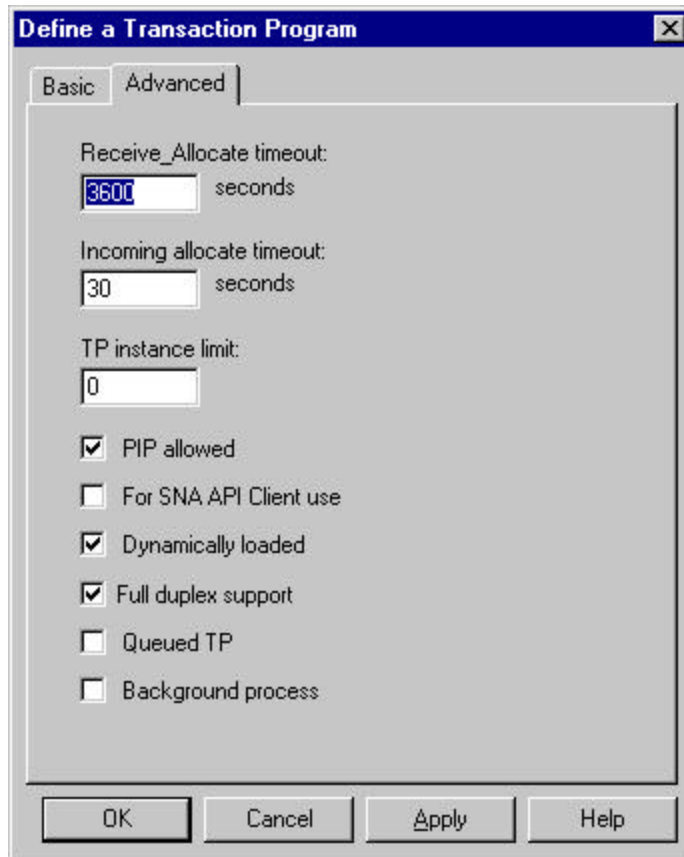

Single-click on the **OK** button at the bottom of the screen to save these specifications to the appropriate *.acg file.

Once you have completed creating this configuration, see [Starting an IBM SecureWay Communications Server for NT Configuration](#).

Guidelines for Configuring Local AS/400 Token-Ring

The following provides guidance for implementing the examples displayed in [AS/400 Token-Ring Example](#) and [AS/400 Configuration Worksheet Examples](#). Note that a subset of the example below displays the pertinent parameters and describing which of these require you to specify *variable_names* and which require a specific name or number, such as `MODETAB=MODEIBM` or `FMPROF=X'13'`.

An underlined value (such as WCONNECT) indicates that the value is a system default.

When [Specifying Communications Server for NT Configuration Profiles](#) (the last guidelines section cited in the list below), please note that Communications Server creates a `xxx.ACG` file (where `xxx` represents the file name you select at the **Welcome to Communications Server Configuration!** window when you first try to configure the node). This `xxx.ACG` file is located in the `C:\IBMCS\private` drive, where `C` is the drive where you choose to install IBM SecureWay Communications Server for NT. For users migrating from PSF Direct on an OS/2 operating system, this `xxx.ACG` file is the equivalent of the OS/2 Communications Manager Communications Server `xxx.NDF` file.

These guidelines consist of the following topics:

- [AS/400 Host Configuration Information](#)
- [Specifying Communications Server for NT Configuration Profiles](#)

AS/400 Host Configuration Information

To learn more about the AS/400 operating system configuration that these commands create to enable your system to work with PSF Direct, you should access both the [AS/400 Information Starting Point](#) at <http://publib.boulder.ibm.com/pubs/html/as400/infocenter.html> and the [AS/400 online Library V4R4 Publications](#) at <http://publib.boulder.ibm.com/pubs/html/as400/online/v4r4eng.htm> on the Web.

The OS/400 Printer Device Programming V4R4 manual provides a great deal of general information on this topic.

To access the bookshelves directly from the [AS/400 online Library V4R4 Publications](http://publib.boulder.ibm.com/pubs/html/as400/online/v4r4eng.htm) page at <http://publib.boulder.ibm.com/pubs/html/as400/online/v4r4eng.htm>,

1. Click on Category Bookshelves for V4R4.
2. Select option #5 (**Host Communications**).

To search AS/400 documentation from the [AS/400 online Library V4R4 Publications](http://publib.boulder.ibm.com/pubs/html/as400/online/v4r4eng.htm) page select **Search or view all V4RE4 books, in English**

Specifying Communications Server for NT Configuration Profiles

This section contains guidelines for configuring the Communications Server for NT Profiles.

AS/400 Node setup

The following describes how to specify the PSF Direct values that are displayed in the [AS/400 Note Setup](#) example.

Basic Configuration

For more information about this configuration view, see [AS/400 Node Configuration Basic example](#).

Fully-qualified Control Point (CP) name

Specifies the name of the component that manages the resources of that node.

If the **CPNAME** operand is used in the VTAM switched major node **PU** statement (rather than **IDBLK** and **IDNUM**), then the **Control Point (CP) name** must match the **CPNAME** operand. By convention, the **CPNAME** is usually the same as the **PU** name. Either the **CPNAME** operand or both the **IDBLK** and the **IDNUM** operands are required. **CPNAME** can only be used with PU type 2.1 nodes, such as Communications Server for NT.

CP alias

Specifies an alternative name for the **CP**. Local applications can use this name, instead of the fully-qualified **CP** name, to refer to the local **CP**.

Local Node ID -

Specifies both the **Block ID** -- a 3-digit hexadecimal string that identifies the product type in an SNA network -- and the **Physical Unit ID** -- a 5-digit hexadecimal string that identifies a physical unit (**PU**).

This identifier is used by the OS/400 operating system to establish a link with this workstation when attached to a token-ring network. The value must be unique within the network and must match the AS/400 APPC controller description **EXCHID** parameter.

Node Type

Specifies the type of node. Take the End node default.

If you are migrating from an AIX operating system, **Node Type** matches the **Control Point Type** parameter.

Advanced Configuration

For more information about this configuration view, see [AS/400 Node Configuration Advanced example](#).

Registration of LU resources

Specifies that directory information about the local logical units (LUs) 6.2 is sent to the server. As the example shows, check both the **Network node server** and the **Central Directory Server**.

Discovery Support

Specifies a LAN address resolution protocol that can be used to find another node that matches given search criteria. By adjusting the search parameter, a node may search for APPN network nodes, nodes that provide SNA boundary function, or AS/400s. Select the check box to enable Discovery Support.

DLU Requester Configuration

For more information about this configuration view, see [AS/400 Node Configuration DLU Requester example](#).

DLUS connect retry timeout

Specifies the time between attempts to reconnect a dependent logical unit server (DLUS). This parameter is based on the **DLUS connect retry limit** parameter. Take the default of 5.

DLUS connect retry limit

Specifies the maximum number of attempts to reconnect a DLUS without receiving an acknowledgment in the time set by the **DLUS connect retry timeout** parameter. Take the default of 3.

AS/400 Device Configuration

The following describes how to specify the PSF Direct values that are displayed in the [AS/400 Device Configuration](#) example.

From the pop-up **Device Type** window, select **LAN** for your Data Link Control (DLC) type. A DLC is a set of rules that nodes on a data link (such as an SDLC link or a Token-Ring) use to accomplish an orderly exchange of information. The **Adapter number** is the only parameter that you should have to either set or change.

Basic Configuration

For more information about this configuration view, see [AS/400 Device Configuration Basic example](#).

Port name

Specifies the port name of the physical connection to the link hardware. This value consists of the word LAN, the adapter number, and the local SAP number, with an underscore between the adapter number and the local SAP number.

Adapter number

Specifies a value from 0 to 7 that uniquely identifies this adapter. Specify this value after you specify LAN as the DLC type.

Local SAP

Specifies the local service access point (SAP) number of the local port as a value from 04 through FC. Note that this number must be a multiple of four. Take the default of 04.

anced Configuration

more information about this configuration view, see [AS/400 Device Configuration Advanced example](#).

) retry interval

Specifies the time the link station waits for a reply to a previous XID command before resending that command. Specify 8. If the link station is a calling link station, this value causes it to try to establish a link connection with the Local 3172 communication controller every 8 seconds, until a link connection can be established. If you are migrating from an AIX operating system to a Windows NT operating system, this parameter replaces the **Response Timeout** parameter from the **Token-Ring SNA DLC** profile.

) retry limit

Specifies the maximum number of times an XID command will be retransmitted before Communications Server for NT presumes that the link is broken and stops retrying. Specify 5. If the link station is a calling link station, this value indicates that there is no limit on the number of attempts the link station makes to establish a link connection with the Local 3172 communication controller. The interval between the attempts is defined by the previous parameter. If you are migrating from an AIX operating system to a Windows NT operating system, this parameter replaces the **XID Retransmit count** parameter from the **Token-Ring SNA DLC** profile.

t retry interval

Specifies the time between attempts to find the adjacent link station on the LAN. This parameter is needed to establish communication with the network and does not necessarily relate to VTAM or the PSF Host system. The number of times an XID is sent is based on the configured **XID retry limit**.

t retry limit

Specifies the number of times COmmunications Server attempts to find the adjacent link station on the LAN. Specify a value from 3 to 30.

Receive window count

Specifies a value that should be equal to the **MAXOUT** value in the VTAM switched major node **PU** statement. The Receive window count defines the size of the link-level window. It specifies the maximum number of frames to receive before sending a link-level acknowledgement. The VTAM **PU MAXOUT** value indicates the number of frames the Local 3172 communication controller sends before waiting for a link-level acknowledgement. If the **MAXOUT** operand is less than the **Receive window count** parameter, extremely poor throughput can result. The default **MAXOUT** value is 1. The default **Receive window count** value is 8. These defaults must be adjusted to yield acceptable throughput.

Maximum PIU size

Specifies a value between 99 and 65535 bytes that represents the maximum number of bytes that are contained in the data buffer used by SNA sessions for this link. If the value of the **Maximum PIU size** exceeds the frame size supported by your local device driver, the value will be reduced to match the frame size.

Performance Configuration

For more information about this configuration view, see [AS/400 Device Configuration Performance example](#).

If you are migrating from an AIX operating system to a Windows NT operating system, see below for how values are mapped:

Windows NT Parameter	AIX Value
Idle timeout	Inactivity time-out
Busy state Timeout	n/a
Acknowledgement delay	n/a
Acknowledgement timeout	Acknowledgement timeout
POLL response timeout	n/a
Anticipated outstanding transmits	Transmit window count
Receive buffer count	n/a

Reactivation Configuration

For more information about this configuration view, see [AS/400 Device Configuration Reactivation example](#).

AS/400 Peer-to-Peer Connection Configuration

The following describes how to specify the PSF Direct values that are displayed in the [Local 3172 Peer-to-Peer Connection Configuration](#) example. This configuration is a call setup because NT searches for and calls the host PSF program.

Basic Configuration

For more information about this configuration view, see [AS/400 Peer-to-Peer Connection Configuration Basic example](#).

Link station name

Specifies a 1- to 8-byte character string that is used to identify a connection

Device name

Specifies the name of the port associated with this link station. This value must match the **Port name** value specified under the Basic options for [Device configuration](#).

Destination address

Specifies a 12-character hexadecimal string that specifies the address to activate a connection to the destination. This value must be specified so the NT system can search for and call the PSF Host program.

Swap address bytes

Check this field to bit-swap the address currently in the **Destination address** field. You may need to select this check box if the next link in the network is an Ethernet link. If not, you can use the default (unchecked).

Advanced Configuration

For more information about this configuration view, see [AS/400 Peer-to-Peer Connection Configuration Advanced example](#).

Activate link at start

Specifies that you will use the link reactivation values specified in the port (device) link reactivation definition. Ensure that you select this check box.

APPN support

Specifies whether CP-CP sessions are supported on this connection. Select the check box to specify APPN support.

PU name

Specifies the physical unit (PU) name is the name of the component that manages and monitors the resources (such as attached links and adjacent link station) associated with a node. The default PU name is automatically created. This definition can be changed.

Block ID

Identifies the product type in an SNA network.

Physical Unit ID

Identifies the physical unit (PU) or component that manages and monitors the resources (such as attached links and adjacent link stations) associated with a node.

Note that the remaining two panels in the Peer-to-Peer Connection Configuration (**Adjacent Node** and **Reactivation**) should take their default values.

Partner LU 6.2 Configuration for AS/400

The following describes how to specify the PSF Direct values that are displayed in the [Local 3172 Partner LU 6.2 Configuration](#) example, which is used to point the personal computer to the host PSF program.

Basic Configuration

For more information about this configuration view, see [AS/400 Partner LU 6.2 Configuration Basic example](#).

Partner LU name

Specifies the network identifier of the network in which the host PSF program resides (followed by a period), and the logical unit name used by the host PSF program. The AS/400 network name (first qualifier) is obtained from the local network ID in the AS/400 network attributes. The PLU second qualifier) is obtained from the AS/400 **LCLLOCNAME** parameter in the AS/400 printer device description. If that device is *NETATR, you use the value specified for the default local location in the AS/400 network attributes. (Do not check the **Wildcard** check box.)

Partner LU alias

Specifies the alternate name for the partner LU. Local applications can use this name, instead of the fully-qualified LU name, to refer to the partner LU. This is the PSF Direct receiver to be used when its real LU is activated by the OS/400 operating system. While you can choose any meaningful value, IBM recommends specifying the second qualifier of the **Partner LU name**.

Fully qualified CP name

Select: **New** to enter the fully-qualified CP name of the partner LU's owning control point. Communications Server for NT requires this field. Infoprint Manager uses this field as the target for any alerts sent by the PSF Direct program.

Advanced Configuration

For more information about this configuration view, see [AS/400 Partner LU 6.2 Configuration Advanced example](#).

Maximum LL record size

Specifies a value between 0 and 32767 as the maximum size of the logical record in the data stream for basic conversations. Specify the default (32767) because the PSF Host program and the PSF Direct Host Receiver should both be able to handle the full range.

Conversation security support

Specifies that the partner logical unit (LU) is authorized to validate the user identifiers for the local LUs. Select the check box to specify conversation security support if you have matching support on the Host PSF program. If not, leave this box unchecked.

Parallel session support

Specifies whether the partner LU supports two or more currently active sessions between the same two LUs using different pairs of network addresses or session identifiers. Because neither PSF Direct nor the PSF Host programs support two sessions with the same Partner LU, do not select this check box.

Local LU 6.2 Configuration for AS/400

The following describes how to specify the PSF Direct values that are displayed in the [AS/400 Local LU Configuration](#) example.

Basic Configuration

For more information about this configuration view, see [AS/400 Local LU 6.2 Configuration Basic example](#).

Local LU name

Specifies a 1- to 8-byte character string that identifies your workstation and gives transaction programs access to the network. This name must match the Partner LU that has been defined at the Host PSF program, as indicated in the [Local AS/400 Worksheet Example](#), as well as the AS/400 printer device description **RMTLOCNAME** parameter.

Local LU alias

Specifies the name for the local LU that is used by Infoprint Manager when configuring the PSF Direct Host Receiver. This is the network addressable unit (NAU) for this logical unit (LU). This parameter value corresponds to the **LOCADR** parameter in the APPC device description and will be created by AS/400. By default, that value is X'00', which means that the AS/400 is an independent LU.

Dependent LU

Specifies whether (if checked) this LU requires assistance from a system services control point (SSCP) in order to initiate an LU-LU session. If you select this check box, ensure that the LU is specified as Dependent on the host PSF program.

SNA API client use

Since this LU is meant to be used by a server-based transaction program (TP), this field should not be checked.

Advanced Configuration

For more information about this configuration view, see [AS/400 Local LU 6.2 Configuration Advanced example](#).

LU session limit

Specifies the maximum number of sessions supported by the LU as a value between 0 and 65535. Specify 5.

Synchronization support

Select this check box if another application is supplying synchronization point management (DB/2, for example). In this instance, do not select it.

Mode Configuration for AS/400

The following describes how to specify the PSF Direct values that are displayed in the [AS/400 Mode Configuration](#) example.

Basic Configuration

For more information about this configuration view, see [AS/400 Mode Configuration Basic example](#).

Mode name

Specifies the characteristics for the session that will be allocated for the conversation. This value is used by the initiator and defines the modes available for Transaction Programs that do not use IBM SecureWay Communications Server for NT-supplied modes. The **Mode name** in the BLANK profile is 8 spaces. This value should match the AS/400 **MODE** parameter in the AS/400 printer device description.

PLU mode session limit

Specifies a value between 0 and 32767 as the primary logical unit (PLU) mode session limit, or maximum number of concurrently active LU-LU sessions that a particular LU can support. Take the default.

Minimum contention winner sessions

Specifies a value between 0 and 32767 as the minimum number of sessions that can be activated by a local logical unit (LU) using this mode to win a contention with a partner. Take the default.

Advanced Configuration

For more information about this configuration view, see [AS/400 Mode Configuration Advanced example](#).

Maximum negotiable session limit

Specifies a value between 0 and 32767 as the maximum number of sessions allowed in this mode between any local logical unit (LU) and partner LU. Take the default

Receive pacing window size

Specifies the lesser of this parameter's value and the **SRCVPAC** value in the VTAM **MODEENT** statement. Specifying 16 yields good throughput in most configurations. This parameter influences performance and can be adjusted as desired.

Auto activate sessions

Specifies a value between 0 and 32767 as the number of parallel LU 6.2 sessions to automatically start when an initial session is started using this mode. Specify 0 so no parallel sessions can be started automatically for this application.

Class of Service name

Specifies the name of a set of transport network characteristics. Select the default:
#CONNECT.

Use default RU size

Instructs the node to use the default maximum size for the request/response unit (RU) sent and received on the sessions. Do not select the check box.

Maximum RU size

Set this value to 1024, if it does not automatically specify that value when you remove the check from the **Use default RU size** parameter above.

AS/400 Transaction Program Configuration

The following describes how to specify the PSF Direct values that are displayed in the [AS/400 Transaction Program Configuration example](#). Note that check box values that should not be selected and most default values are not described.

Basic Configuration

For more information about this configuration view, see [AS/400 Transaction Program Configuration Basic example](#).

TP name

Specifies a 1- to 64-byte character string for the program that uses the advanced program-to-program communications (APPC) system to communicate with a partner application program at the partner node. Select \$DPF. For users migrating from an AIX operating system to a Windows NT operating system, note that this value changes from a binary 30F0F0F0 to a non-binary \$DPF. Ensure that the **Service TP** check box is unchecked because it indicates a non-binary value.

Complete pathname

Specifies an 1- to 255-byte character string that describes the location of the program to be executed, the PSF Direct host receiver program. The location can include the drive, the directory, the subdirectory, and the file name. For the [AS/400 Transaction Program Configuration example](#), d:\ipmnt\bin\ainhr.exe specifies the location where Infoprint Manager for NT is installed on your system.

Conversation type

Specifies the conversation type allowed to start the transaction programs (TPs) using an LU 6.2 session. Select **Basic** for Basic conversation for system TPs.

Synchronization level

Specifies the level allowed on allocation requests that start the local and remote transaction programs (TPs). Select **Any**.

Conversation security required

Allows controlled access to system resources through security parameters associated with a request for access to those resources. If this check box is selected, conversation security information is required to start the TP. Incoming allocation requests for this TP without the conversation security information will be rejected. Do not check this box.

Advanced Configuration

Ensure that **Dynamically loaded** and **Background process** (the two items checked in the [AS/400 Transaction Program Configuration Advanced example](#)) are the only items checked. If you specify other options, this transaction program will not work.

Receive_Allocate timeout

Specifies a value between 0 and 65535 seconds that identifies the time that a Receive_Allocate verb will be queued while waiting for an Attach. Specify 60.

Incoming allocate timeout

Specifies a value between 0 and 65535 seconds that identifies the time that an incoming Attach will be queued waiting for a Receive_Allocate. Specify 60.

TP instance limit

Specifies a value between 0 and 65535 seconds that identifies the maximum number of concurrently active TP instances. Specify at least 1 (or the number of LU's that you have defined).0 means no limit.

Dynamically loaded

Specifies whether the transaction program (TP) can be dynamically started by an allocation request received on a conversation. Select the check box to dynamically load the TP.

Background process

Specifies that the program will execute in the background. Only 32-bit programs can multitask in the Windows NT environment. Select the check box to use the background process.

Local or Remote AS/400 Token-Ring Configuration Worksheets

Use the following worksheets to configure PSF Direct on both the host PSF and Infoprint Manager for NT:

- Use the [AS/400 Worksheet Example](#) to see how IBM SecureWay Communications Server for NT configuration settings used in the [AS/400 Token-Ring Example](#) related to other configuration settings
- Use the [AS/400 Worksheet Sample](#) to record IBM SecureWay Communications Server for NT values used at your installation that related to other configuration settings.

AS/400 Worksheet Example

Communication Server	Token-Ring Line Description	APPC Controller Description	Printer Device Description	Network Attributes
Max I-field size	16393	16393		
Network name		USIBMBQ	USIBMBQ	
Local node name		NT2		
Node ID		05DC021C		
Full PLU name			APPN.BLDAS44	APPN.BLDAS44
LU 6.2 Local LU: Local LU name			AS4TEST	
LU 6.2 Mode: Receive pacing window			QSPWTR	
Destination address	400059550067			
LAN adapter address		400059550067		

AS/400 Worksheet Sample

Communication Server	Token-Ring Line Description	APPC Controller Description	Printer Device Description	Network Attributes
Max I-field size	MAXFRAME	MAXFRAME		
Network name		RMTNETID	RMTLOCNAME	
Local node name		RMTCPNAME		
Node ID		EXCHID		
Full PLU name			LCLLOCNAME	Local network ID
LU 6.2 Local LU: Local LU name			RMTLOCNAME	
LU 6.2 Mode: Receive pacing window Is this the same as Mode name?			MODE	
Destination address	ADPTADR			
LAN adapter address		ADPTADR		

Starting an IBM SecureWay Communications Server for NT Configuration

Use the following procedure to start all IBM SecureWay Communications Server for NT configurations that you created from the Network Configuration Examples and Guidelines.

1. From your NT desktop view, double-click on the **SNA Node Operations** icon that resides on your desktop:



2. From the **Communications Server Node Operations** window, click on the plus (+) sign next to **Connections**.
3. If your configuration is an independent LU, highlight **Peer Connections**. If it is a dependent LU, highlight **Host Connections**.
4. From the window's main menu, select **Operations-->Start Node**.
5. From the **Open** pop-up window, select the *.acg file that represents the configuration you wish to start and click **Open**.

From the right pane of the **Communications Server Node Operations** window, a lightning bolt icon with a Linkxxx description (where xxx represents the number of links on your system) appears. When the lightning bolt icon turns completely **yellow**, the link is active and PSF Direct is ready to receive jobs from the host PSF system. If the lightning bolt turns completely **red**, the link has failed and you need to review your configuration on both the Infoprint Manager Windows NT server and the PSF host program.

Configuring PSF Direct

PSF Direct acts as a communication protocol converter that exchanges data with a host PSF program using an SNA LU 6.2 session, and relays the data to an Infoprint actual destination.

From an application perspective, the entire SNA network can be viewed as a black box with two access points called **logical units**. An LU 6.2 session runs through the network and connects the two logical units, as displayed in the end-to-end view of logical components of a PSF Direct configuration displayed below.

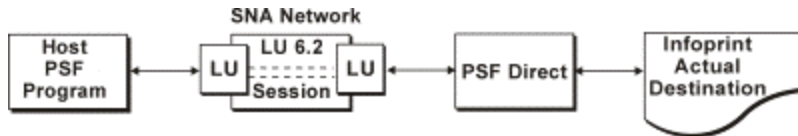

When you configure a PSF Direct Receiver, you associate a logical unit with an Infoprint actual destination (as shown below):



Creating and Configuring an Infoprint PSF Direct Destination (printer)

Before creating an actual destination (printer) to send jobs from PSF Direct, you should determine the type of configuration. See the Administrative procedure "Selecting a type of actual destination," which can be found at the Infoprint Manager for Windows NT sitelet at <http://www.ibm.com/printers>. When you create an Infoprint actual destination, Infoprint adds the facilities required for Infoprint to communicate with the printer. These include a subdirectory and files in the `\var\psf` directory.

For PSF Direct, you can create and configure the Infoprint PSF Direct destination in two ways:

- [Using the Infoprint Manager Administration GUI](#)
- [Using the Infoprint Manager Management Console](#)

Using the Infoprint Manager Administration GUI

If you will be using the PSF Direct destination to print data from a PC-based source as well as from a host system, you must use the **Infoprint Manager Administration GUI** to create an actual destination. Use the **Printer-->Create-->PSF** menu to access the **Create Printer Wizard** and refer to the online help in the **Infoprint Manager Administration GUI**.

To configure the PSF Direct destination created above, you can use the **Infoprint Manager Administration GUI**. Select the actual destination (printer) you want to configure, then use the **Printer-->Properties** menu to open the **Printer Properties Notebook** and refer to the online help in the **Infoprint Manager Administration GUI**.

Using the Infoprint Manager Management Console

If you will be using the PSF Direct destination to print data from PSF host systems only, you can use the Infoprint Manager Management Console to create an actual destination. Ensure that the Infoprint Windows NT server is running and use the **Edit-->New-->Destination** path and select from the range of potential PSF Direct destinations provided. For more information on configuring this destination, see the related **Infoprint Manager Management Console** help.

To communicate with an Infoprint actual destination, PSF Direct uses the facilities that Infoprint created when you added the printer. However, PSF Direct does not accept data from the Infoprint queue that was created for the printer. Rather than obtaining print data from the Infoprint queue, PSF Direct uses an SNA LU 6.2 session that you created through IBM SecureWay Communications Server for NT to obtain print data from a host PSF program.

When you add a PSF Direct receiver, you must indicate which Infoprint actual destination the host receiver should use. This procedure is described in [Defining the PSF Direct Host Receiver](#).

Defining the PSF Direct Host Receiver

IBM recommends setting up the PSF Direct Receiver and managing your PSF Direct operations from the **MVS Download Receiver Manager** window so you can use the **Management Console for Infoprint Manager Server...** window to track Server events.

To set up a PSF Direct Receiver, use the following procedure:

1. From the **Management Console for Infoprint Manager Server...** window, use the **Edit-->PSF Direct Receiver Management...** menu to access the **PSF Direct Receiver Manager** window.
2. Click on the **Add** button.
3. From the **Add PSF Direct Receiver** pop-up menu, specify a value in the **SNA LUNAME** field that matches the SNA Logical Unit name defined through the Secure Way Communication Server configuration.
4. Click on the drop-down menu next to the **Target Destination** field and highlight the Infoprint logical or actual destination to which you want to default for this PSF Direct Receiver.

This list consists of all the logical and actual destinations that have been defined in the **Infoprint Manager Administration GUI**.

5. Allow both numeric values in the the **SNA System Services Control Point ID** field and the **NMVT Subsystem name** field to default.
6. Specify a numeric value from 0 to 9999 (in seconds) for the **Inactivity limit** field.

Setting this value to the system default of 9999 causes the PSF Direct receivers to wait indefinitely if the printer is not available. For more information about the **Inactivity limit** field, see [Automatically Stopping a PSF Direct Host Receiver](#).

7. Specify a numeric value from 0 to 9999 (in seconds) for the **Printer busy limit** field.

Setting this value to the system default of 9999 causes the PSF Direct receivers to wait indefinitely if the printer is not available. For more information on setting this field, see both [Controlling the Wait Period for a PSF Direct Host Receiver](#).

8. Once you are satisfied with the fields on the **Add PSF Direct Receiver** pop-up menu, click on the **Ok** button.
9. Infoprint adds a PSF Direct Receiver to the main pane, with a red marker and STOPPED displaying in the **Status** column.
10. Within a minute or two, the PSF Direct Receiver that you just created will change marking from red to green and RUNNING will display in the **Status** column. At this point, you can submit jobs from the MVS host system for printing directly on Infoprint Manager printers.

For examples of PSF Direct Receivers created for different host programs, see [PSF Direct Host Receiver: Examples](#).

Starting a PSF Direct Host Receiver

IBM SecureWay Communications Server for NT starts a PSF Direct receiver automatically when a host PSF program causes an SNA LU 6.2 session to be established and allocates an SNA conversation on that session. As a result, a host system operator indirectly causes a PSF Direct host receiver to be run by starting a host PSF program that causes IBM SecureWay Communications Server for NT to begin the PSF Direct host receiver.

The operator on the Infoprint Manager Windows NT server does not need to do anything to start a PSF Direct host receiver, as long as IBM SecureWay Communications Server for NT is active on the Windows NT server.

Stopping a PSF Direct Host Receiver

A PSF Direct host receiver can be stopped in several ways:

- The host system operator can end the host PSF program that communicates with the PSF Direct host receiver. When the host PSF program ends the SNA conversation with the PSF Direct host receiver, the PSF Direct host receiver automatically ends.
- The host PSF program's **Disconnect Interval** parameter can be exceeded.

If the host PSF program is waiting for new print files and none become available within the period specified by the **Disconnect Interval** parameter, the host PSF program ends the SNA session with the PSF Direct host receiver. The PSF Direct host receiver then ends.

- The PSF Direct host receiver **Inactivity Limit** can be exceeded.

If the PSF Direct host receiver is waiting for data from the host PSF program and no data arrives within the period specified by the **Inactivity Limit** value, the PSF Direct host receiver UNBINDs the SNA session with the host system.

The **Inactivity Limit** defaults to infinite (9999 seconds) and should only be used in some configurations where a printer is shared.

- If an operator at the Windows NT system stops IBM SecureWay Communications Server for NT, all SNA sessions end, causing all PSF Direct host receivers to end. An operator can also use IBM SecureWay Communications Server for NT to stop an individual SNA session. If the session was used by a PSF Direct host receiver, that PSF Direct host receiver ends.

For information about stopping a PSF Direct host receiver working with a shared Infoprint actual destination, refer to both [Manually Stopping a PSF Direct Host Receiver](#) and [Automatically Stopping a PSF Direct Host Receiver](#).

Displaying the Status of a PSF Direct Destination on the Windows NT/2000 System

Infoprint provides two methods for users to display the status of a PSF Direct host receiver:

- [the Infoprint Manager Management Console](#)
- [the psfstat command](#)

The **Infoprint Manager Management Console** allows you to view the status of Infoprint actual destinations and PSF Direct Receivers. If you click on **PSF Direct Host Receivers** in the left pane, the **PSF Direct Host Receivers** view shows up in the right pane. If you are not using the **Management Console for Infoprint Manager Server...** window to track server events, this is the easiest method to display PSF Direct status. However, if you are using the **Management Console for Infoprint Manager Server...** window to track server events, you should use the **psfstat** command to display status.

Note that if you click **destinations** in the left pane of the **Management Console for Infoprint Manager Server...** window, Infoprint displays the status of all your actual destinations.

The **psfstat** command displays information about the status of Infoprint actual destinations and PSF Direct receivers. It tells you whether each Infoprint printer is receiving data from either the Infoprint Manager Windows NT server or from a PSF Direct receiver. The **psfstat** command provides the source of the display provided by the **Infoprint Manager Management Console**.

Specifying `psfstat` from a Command Prompt window could display the following:

Printer	Attachment	Data	Printer status	Active	Waiting
3827	channel	IPDS	--	--	--
4000wa	TCP/IP	IPDS	intervention	[Queue]	--
4000wb	TCP/IP	IPDS	ok	PSFVM1	[Queue], PSFMVS
ps14	direct	PS	ok	[Queue]	--

LU name	Printer	Attachment	Data	Printer status	Receiver Status
PSFMVS	4000wb	TCP/IP	IPDS	ok	sess/prtr_busy
PSFVM1	4000wb	TCP/IP	IPDS	ok	sess/prtr_con
PSFVSE1	4000wb	TCP/IP	IPDS	ok	idle

This display indicates that

1. Printer 3827 is not active.
2. Printer 4000wa is printing data from Infoprint Manager ([Queue]) and operator intervention is required at the printer.
3. Printer 4000wb is printing data from a PSF Direct receiver that uses the SNA logical unit name (**LUNAME**) PSFVM1. Additional data is also available on the Infoprint actual destination and from a PSF Direct receiver that uses the SNA **LUNAME** PSFMVS. The order of the waiting data sources does not indicate which source will access the printer next.
4. Printer ps14 is printing data from Infoprint Manager.
5. Receiver PSFMVS is in session with the host system and is waiting for printer 4000wb.
6. Receiver PSFVM1 is in session with the host system and is connected to printer 4000wb.
7. Receiver PSFVSE1 is in session with the host system and is idle, but connected to printer 4000wb.

Note that the **psfstat** command can be used to display information about any Infoprint actual destination, not just those used by PSF Direct host receivers. For the syntax of the **psfstat** command, see the *Infoprint Manager Reference*.

Displaying the Status of a PSF Direct Destination on the Host System

A host system operator can display the status of any printer managed by the host PSF program, including printers attached by PSF Direct. For example, an MVS operator can use the JES2 **\$DU** command to display printer status.

Using One Infoprint Actual Destination to Print Data from Multiple Sources

One Infoprint actual destination can print data from more than one host PSF program and from the IBM Infoprint Windows NT server. At any point in time, however, the Infoprint actual destination can only be dedicated to printing data from a single source: one host PSF program or the IBM Infoprint Windows NT server.

This topic describes how to configure and manage the switching of an Infoprint actual destination between data sources:

- [Switching between data sources](#)
- [Sharing an Infoprint actual destination](#)
- [Displaying the status of a shared Infoprint actual destination](#)

Switching between Data Sources

Switching an Infoprint actual destination between data sources requires two steps:

1. The PSF Direct host receiver using an Infoprint actual destination must end; or the Infoprint process printing from the IBM Infoprint Windows NT server must end. When this process ends, the Infoprint actual destination becomes available to another program.
2. A PSF Direct host receiver or Infoprint process that prints from the IBM Infoprint Windows NT server must wait for the Infoprint actual destination while it is used by another program.

Manually Stopping a PSF Direct Host Receiver

A host system operator can end a PSF Direct host receiver by ending the host PSF program that communicates with the host receiver.

For example, an MVS host operator can “purge” the printer using the **\$PPRT***nnn* JES2 command; or the operator can cancel the JES writer procedure.

To end the IBM Infoprint Windows NT server process manually from Infoprint, refer to the **pdshutdown** command as described in *Infoprint Manager Reference*. If you merely disable the printer through the **pddisable** command, the Infoprint processes are not stopped and the PSF Direct host receiver cannot establish a session.

For more detail about shutting down a PSF Direct host receiver, see [Stopping a PSF Direct Host Receiver](#).

Automatically Stopping a PSF Direct Host Receiver

Most host PSF programs have a “Disconnect Interval” configuration parameter, such as the **DISCINTV PRINTDEV** statement parameter in PSF/MVS. This parameter causes the host PSF program to end the SNA session with a PSF Direct host receiver if there is no data to print for the specified period. Ending the SNA session with the host receiver causes the host receiver to end.

Some host PSF programs, such as PSF/400, do not offer a “Disconnect Interval” configuration parameter. To enable PSF Direct host receivers to be automatically ended when they communicate with a host PSF program that does not offer a “Disconnect Interval” configuration parameter, the PSF Direct host receiver configuration panel includes an **Inactivity limit** parameter.

The PSF Direct host receiver **Inactivity limit** parameter causes a host receiver to end if it waits for data from the host system for the specified period.

Using the host PSF program's “Disconnect Interval” is preferable to using the PSF Direct host receiver **Inactivity limit** parameter.

Automatically Stopping Printing from the IBM Infoprint Windows NT Server

Each Infoprint actual destination has an actual destination attribute called the **printer-release-timer** attribute. This attribute causes Infoprint to stop printing from IBM Infoprint Windows NT Server if it has completed the Infoprint spool data and the specified interval elapses with no new IBM Infoprint Windows NT Server data.

Controlling the Wait Period for a PSF Direct Host Receiver

The PSF Direct host receiver **Device busy limit** parameter controls how long a host receiver waits for an Infoprint actual destination to become available. The **Device busy limit** parameter has a default value of 120 seconds. If an Infoprint actual destination is used to print from several sources, increase the **Device busy limit** parameter to 9999, which means that the host receiver should wait indefinitely.

While a PSF Direct host receiver is waiting for an Infoprint actual destination to become available, the SNA session with the host system is maintained but no application data is exchanged.

Controlling the Wait Period for Printing from an IBM Infoprint Windows NT Server

By default, the Infoprint program that prints from the IBM Infoprint Windows NT Server waits indefinitely for an Infoprint actual destination to become available. There is no configuration attribute that controls how long the program waits.

The following table summarizes the time limits for Infoprint printing:

Selected Time Limit Parameters				
For Device	Function	Option	User Interface	Default Value
PSF Direct Host Receiver	Wait for printer	Device Busy Limit field.	PSF Direct Receiver Manager window of Infoprint Manager Management Console .	120 seconds
PSF Direct Host Receiver	End program, making printer available.	DISCINTV	Host PSF configuration program	0 seconds (infinite)
PSF Direct Host Receiver	End program, making printer available.	Inactivity limit field.	PSF Direct Receiver Manager window of Infoprint Manager Management Console .	9999 seconds (infinite)
IBM Infoprint Windows NT Server	Wait for printer	none	none	infinite
IBM Infoprint Windows NT Server	End program, making printer available.	printer-release-timer attribute	On the Infoprint Manager Administration GUI , the PSF Configuration tab of the Printer Notebook .	9999 seconds (infinite)

Sharing an Infoprint Actual Destination: An Example

The following example illustrates how an Infoprint actual destination could be shared between two host PSF programs using PSF Direct and also print data from the IBM Infoprint Windows NT Server.

The configuration parameters cause the printer to be switched automatically.

This section consists of the following topics:

- [Host PSF Program Configuration: Examples](#)
- [Infoprint Actual Destination: PSF Tuning Options](#)
- [PSF Direct Host Receiver: Examples](#)

Host PSF Program Configuration: Examples

For two host PSF programs to share an Infoprint actual destination, they must specify similar **PRINTDEV** statements. Note that the colon (:) indicates that the complete statement would contain more parameters.

Selected PSF/MVS **PRINTDEV** parameters:

```
// PRT833 PRINTDEV
:
//          DISCINTV=60 ,          /*DISCONNECT INTERVAL -- SECONDS
          */
::
// PRT833 ENDCNTL
```

Selected PSF/VSE **PRINTDEV** parameters:

```
    PRT100
    0 PRINTDEV
:
          DISCINTV=60 ,          DISCONNECT INTERVAL -- SECONDS
::
```

Setting the **DISCINTV** to 60 seconds for both host PSF programs causes each host PSF program to end if all spool data from the printer is completed and no additional data becomes available for 60 seconds. When the host PSF program ends, the PSF Direct host receiver ends, and the Infoprint actual destination becomes available to other programs.

If additional host data becomes available for the Infoprint actual destination, the host PSF program starts again and waits, if necessary, for the printer to become available.

Infoprint Actual Destination: PSF Tuning Options

To allow Infoprint to share the printer with two host PSFs, you must adjust the Infoprint actual destination's PSF tuning options from the **Printer Properties** in the **Infoprint Manager Administration GUI**.

Select the actual destination (printer) you want to configure, then use the **Printer-->Properties** menu to open the **Printer Properties** notebook, select the **Tuning** tab, and tune the options described in this section.

The **Release time (sec)** field (or **destination-release-timer** attribute) specifies the amount of time between jobs (in seconds) that Infoprint waits before giving up control of an actual destination. Setting this value to 60 seconds causes the Infoprint program that prints from the IBM Infoprint Windows NT server to end if it has printed the files in the printer's queue and no additional files become available for 60 seconds. When the program ends, the Infoprint actual destination becomes available to other programs such as PSF Direct receivers.

If additional files are added to the printer's queue on the IBM Infoprint Windows NT server, the Infoprint program that prints from the server starts again and waits, if necessary, for the printer to become available.

Accepting the default **intervention-timer** attribute value of 9999 causes the PSF Direct host receivers that use this printer to issue printer intervention messages on the Windows NT system, but not to report intervention conditions to the host PSF program.

If an **intervention-timer** value of 3600 were used instead, the PSF Direct receivers that use this printer would notify the host PSF program if an intervention condition were not addressed within an hour. The host PSF program would issue an operator message and end the SNA session with the PSF Direct receiver. The **intervention-timer** would also cause the PSF program that prints from the IBM Infoprint Windows NT server to end if an intervention condition were not addressed within an hour.

For continuous-forms printers, set the **Non-process-runout-timer** field at a lower value than what is set for the **Release-time (sec)** attribute. For example, if the `destination-release-timer = 60` seconds, the `non-process-runout-timer` attribute should be reduced to 30 seconds.

PSF Direct Host Receiver: Examples

Finally, you must configure the PSF Direct host receivers for each host that will share the printer. This process is described in [Defining the PSF Direct Host Receiver](#).

Sample PSF Direct host receiver values for a PSF/MVS host:

SNA Logical Unit Name	MVS1
Target Destination (actual destination)	4000wb
Inactivity limit (seconds)	9999
Device busy limit (seconds)	9999
SNA System Services Control Point ID	050000000000
NMVT Subsystem Name	NMVT

Sample PSF Direct host receiver values for a PSF/MVS host:

SNA Logical Unit Name	VSE1
Target Destination (actual destination)	4000wb
Inactivity limit (seconds)	9999
Device busy limit (seconds)	9999
SNA System Services Control Point ID	050000000000
NMVT Subsystem Name	NMVT

Displaying the Status of a Shared Infoprint Actual Destination

The **psfstat** command displays information about the status of Infoprint actual destinations and PSF Direct receivers. The information **psfstat** displays about an Infoprint actual destination includes the program that currently controls the printer and a list of the programs waiting to gain control of the printer.

For example, **psfstat** might display the following:

```

Printer Attachment  Data  Printer
                    status
-----
4000wb  TCP/IP      IPDS  intervention  MVS1      [Queue],VSE1

LU name Printer      Atta
                    chme  Data
                    nt
-----
MVS1    4000wb      TCP/  IPDS
                    IP
VSE1    4000wb      TCP/  IPDS
                    IP
                    intervention  sess/prtr_con
                    on              n
                    intervention  sess/prtr_bus
                    on              y

```

This **psfstat** output shows that the printer is currently dedicated to printing data from the MVS spool. There is also data on the IBM Infoprint Windows NT server ([Queue]) and the VSE spool waiting to print.

When the MVS host system releases the printer, the printer will print data either from the IBM Infoprint Windows NT server or the VSE host system. The order in which the two waiting sources are listed does not imply that the IBM Infoprint Windows NT server has been waiting longer or will acquire the printer next.

The **psfstat** output also indicates that the printer requires intervention.

For more information about the **psfstat** command, see both [Displaying the Status of a PSF Direct Destination on NT](#) and the *Infoprint Manager Reference*.

