

IBM InfoPrint Manager for Windows NT



PSF Direct: 37xx Configuration (3/24/2000)

37xx Token-Ring Example: Table of Contents

I. Overview on PSF Direct and Communication Server for NT	1
What is PSF Direct?	1
What is IBM SecureWay Communications Server for NT?	2
What are the Available Network Connections?	3
II. Configuration Planning	4
Understanding PSF Direct Configuration Requirements	4
Application View of an SNA Network	5
Network Internals View of an SNA Network	7
Key Configuration Parameter Interrelationships	8
Preconfiguration Decisions for all PSF Direct Examples	13
Defining devices for IBM SecureWay Communications Server and Infoprint Windows NT	14
Using an alternate token-ring address for a Windows NT server	14
Decide whether to define a dependent or an independent LU	15
Configuring an LU 6.2 Partner LU on your Infoprint Windows NT Server	16
Enable SNA API Clients on your Infoprint Windows NT server	16

Infoprint Manager for Windows NT and Windows 2000

<u>III. Local or Remote 37xx Token-Ring</u>	17
<u>37xx Host Configuration Examples</u>	17
<u>JES2 Initialization Statement Example</u>	18
<u>JES2 External Writer Procedure Example</u>	18
<u>VTAM Start Option List (ATCSTRxx) Example</u>	20
<u>VTAM Configuration List (ATCCONnn) Example</u>	20
<u>VTAM Application Program Major Node and Application Program Example</u>	21
<u>VTAM Mode Table and Entry Example</u>	21
<u>VTAM Switched Major Node Example</u>	22
<u>Network Control Program (NCP) Definitions Example</u>	23
<u>Accessing the Communications Server for NT Profiles</u>	24
<u>Communications Server for NT Configuration Profile Examples</u>	25
<u>37xx Node setup</u>	26
<u>37xx Device configuration</u>	30
<u>Enabling SNA API Clients for Local 37xx</u>	35
<u>37xx Peer connection configuration</u>	36
<u>37xx Partner LU 6.2 configuration</u>	42
<u>37xx Local LU 6.2 configuration</u>	45
<u>37xx Mode Configuration</u>	48
<u>37xx Transaction program configuration</u>	51

Infoprint Manager for Windows NT and Windows 2000

<u>Guidelines for Configuring Local or Remote 37xx Token-Ring</u>	54
<u>Local or Remote 37xx Host Configuration Information</u>	54
<u>Specifying the JES2 Initialization Statement</u>	55
<u>Configuring the Host PSF Printer</u>	55
<u>Specifying the VTAM Start Option List (ATCSTRxx)</u>	58
<u>Specifying the VTAM Configuration List (ATCCONnn)</u>	59
<u>Specifying the VTAM Application Program Major Node and Application Program</u>	59
<u>Specifying the VTAM Mode Table and Entry</u>	59
<u>VTAM Switched Major Node Example</u>	60
<u>Specifying the Network Control Program (NCP) Definitions</u>	65
<u>Specifying Communications Server for NT Configuration Profiles</u>	67
<u>Node Setup</u>	67
<u>Device Configuration</u>	69
<u>Enable SNA Clients on your Infoprint Windows NT Server</u>	16
<u>Peer Connection Configuration</u>	72
<u>Partner LU 6.2 Configuration</u>	73
<u>Local LU 6.2 Configuration</u>	75
<u>Configuring Modes</u>	76
<u>Transaction Program Configuration</u>	78

Infoprint Manager for Windows NT and Windows 2000

[Local or Remote 37xx Configuration Worksheets](#)

[37xx Worksheet Example](#)

[37xx Worksheet Sample](#)

[Starting an IBM SecureWay Communications Server for NT Configuration](#)

IV. Configuring PSF Direct	84
Creating and Configuring an Infoprint PSF Direct Destination (printer) .	84
Using the Infoprint Manager Administration GUI . .	85
Using the Infoprint Manager Management Console	85
Defining the PSF Direct Host Receiver	85
Starting a PSF Direct Host Receiver	87
Stopping a PSF Direct Host Receiver	87
Displaying the Status of a PSF Direct Destination on the Windows NT/2000 System	88
Displaying the Status of a PSF Direct Destination on the Host System	90

Infoprint Manager for Windows NT and Windows 2000

<u>Using One Infoprint Actual Destination to Print Data from Multiple Sources</u>	90
<u>Switching between Data Sources</u>	91
<u>Manually Stopping a PSF Direct Host Receiver</u>	91
<u>Automatically Stopping a PSF Direct Host Receiver</u>	92
<u>Automatically Stopping Printing from the IBM Infoprint Windows NT Server</u>	92
<u>Controlling the Wait Period for a PSF Direct Host Receiver</u>	92
<u>Controlling the Wait Period for Printing from an IBM Infoprint Windows NT Server</u>	93
<u>Sharing an Infoprint Actual Destination</u>	94
<u>Host PSF Program Configuration: Examples</u>	94
<u>Infoprint Actual Destination: PSF Tuning Options</u>	95
<u>PSF Direct Host Receiver: Examples</u>	96
<u>Displaying the Status of a Shared Infoprint Actual Destination</u>	97

Overview on PSF Direct and Communication Server for NT

The following topic contains an overview of the components you need to configure PSF Direct on SNA networks. This topic contains the following:

- [What is PSF Direct?](#)
- [What is IBM SecureWay Communications Server for NT?](#)
- [What are the Available Network Connections?](#)

What is PSF Direct?

PSF Direct provides a direct connection between an MVS, VSE, VM, or AS/400 system and a printer defined to IBM Infoprint Manager for NT. PSF Direct gives you control of key print processes from your mainframe console: an Infoprint physical printer appears to be directly attached to your mainframe system. Jobs print without delay because they are not spooled by the NT workstation. Because the mainframe controls the print process, it returns job-completion and error messages to the mainframe.

PSF Direct uses Communication Server LU6.2 protocols to communicate between the mainframe and the NT system; then PSF Direct uses one of several protocols to communicate between the NT system and the printer:

- TCP/IP
- Channel
- Parallel/Serial

These protocols provide you with access to TCP/IP, Channel, or Parallel/Serial printers that otherwise you might not be able to attach from the mainframe.

To use PSF Direct, you need the IBM SecureWay Communications Server product to communicate between the mainframe and NT. You create printer definitions on the mainframe so that print jobs can be directed to the NT printer. Then, you define the printer to the IBM Infoprint server on NT.

After PSF Direct is installed, you send the job to the printer, using normal print-submission processes. Because PSF Direct is a direct pipeline to the printer, you need to end the PSF Direct session before you can use the printer to print from another mainframe or from IBM Infoprint Manager for NT.

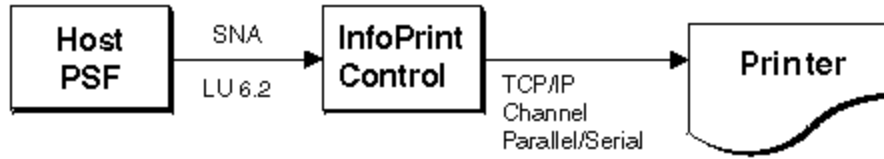

What is IBM SecureWay Communications Server for NT?

The IBM SecureWay Communications Server for NT is required to configure and to use PSF Direct. IBM SecureWay Communications Server is an implementation of SNA for the NT operating system running on the NT workstation. It enables an NT workstation to communicate with other nodes in an SNA network.

Infoprint Manager for NT allows you to create a PSF Direct Host Receiver whether or not you have completed the IBM SecureWay Communications Server node configuration.

PSF Direct requires IBM SecureWay Communications Server for NT system software Version 6, Release 01, with maintenance that includes the following authorized program analysis report (APAR) fixes:

- APAR JR13453
- APAR JR14098
- APAR JR13599

Note that the second APAR (JR13599) is necessary only if you will be creating more than one Communications Server profile for Dependent LUs.

Because Infoprint Manager for NT allows you to create a PSF Direct Host Receiver whether or not you have completed the IBM SecureWay Communications Server node configuration, it does not matter whether you install Infoprint Manager or Communications Server first.

To install IBM SecureWay Communications Server from the CD-ROM:

1. Select the **Install Products** icon that appears on the main window.
2. Choose a **Server** install.
3. From the **Communications Server Installation**, you should select only the **Communications Server for Windows NT** option to use the PSF Direct function.

Once you have completed the installation, create shortcuts for both the **SNA Node Configuration** interface (a default path of `C:\IBMCS\pcscfg.exe` where *C* is the drive where you installed IBM SecureWay Communications Server for NT) and the **Communications Server Node Operations** interface (a default path of `C:\IBMCS\pcsnops.exe` where *C* is the drive where you installed IBM SecureWay Communications Server for NT), so they can be easily invoked from your desktop.

What are the Available Network Connections?

This document includes detailed examples and guidelines for five common SNA configurations. The diagrams in this section illustrate the five network configurations, with references to where more detailed information is provided.

1. Local or Remote 37xx Token-Ring Configuration:

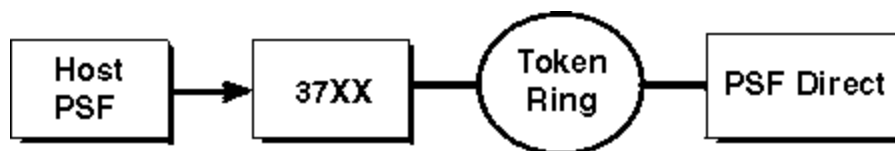

2. Local 3172 Token-Ring Configuration:

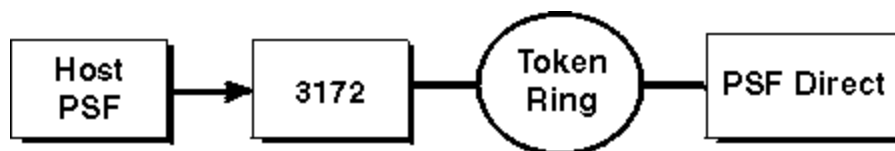

3. Local 3174 Token-Ring Gateway Configuration:

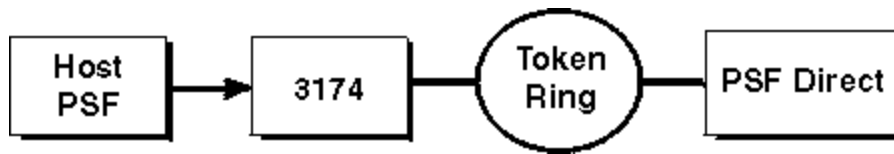

4. Remote 3174 Token-Ring Gateway Configuration:

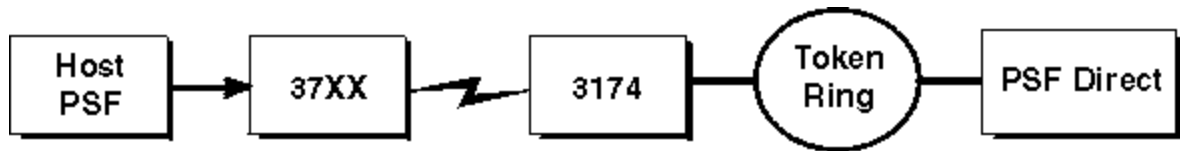

Configuration Planning

All PSF Direct configuration examples require that you understand the following information before creating each individual configuration:

- [Understanding PSF Direct Configuration Requirements](#)
- [Preconfiguration Decisions for all PSF Direct Examples](#)
- [Host Configuration Examples](#)
- [Accessing the Communications Server for NT Profiles](#)
- [Communications Server for NT Configuration Profile Examples](#)

Understanding PSF Direct Configuration Requirements

An SNA network provides powerful communication capabilities to applications without requiring that the applications be aware of the equipment and transmission facilities that comprise the network. So, an SNA application like PSF Direct can communicate using an SDLC telecommunications link between two continents or a Token-Ring LAN in a single room.

To configure an SNA application, one normally need only identify the communication partner and the guidelines for exchanging data.

To configure an SNA network, the internal components of the network and details of their operation must be described.

Considering two views of an SNA network, an [application view](#) and a [network internals view](#), aids in understanding PSF Direct configuration requirements. An overview of the [Key Configuration Parameter Interrelationships](#) when defining logical unit (LU) names follows.

Application View of an SNA Network

An SNA network provides two access points for communication and a logical connection between the two access points. In SNA terminology, the access points are **logical units (LUs)** and the connection between them is a **session**. A **mode** describes a session's characteristics, or guidelines for exchanging data.

The application view displayed in the figure below illustrates the interface that SNA provides to applications, such as the host PSF program and the PSF Direct component of Infoprint Manager. These applications are isolated from details of the internal components of the SNA network.

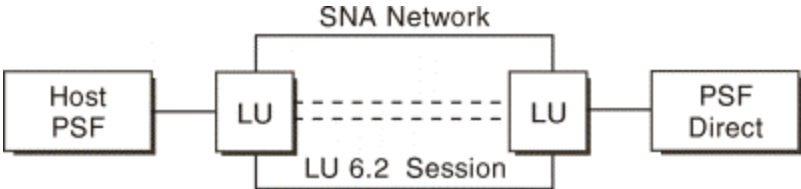

As the application view suggests, only a few values are required to configure the host PSF program and PSF Direct so they can communicate. The following figure displays the values used by both applications. Note that each configuration parameter references a logical unit or mode provided by the SNA network.

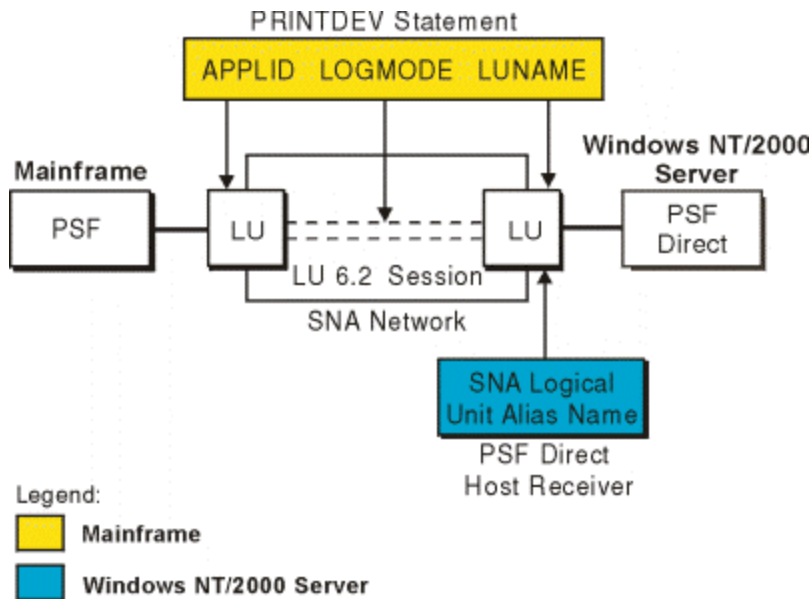

Host **PSF PRINTDEV** Statement Parameters:

APPLID

Specifies the name of the logical unit that the host PSF program uses.

LUNAME

Specifies the name of the logical unit that PSF Direct uses.

LOGMODE

Specifies the session characteristics for communication between the two logical units.

Individual modes, or mode entries, are grouped into a table that contains several modes. **LOGMODE** identifies a mode entry. You identify the mode table through the SNA network definitions for the logical unit that PSF Direct uses.

PSF Direct Host Receiver Parameters:

SNA Logical Unit Alias name

Specifies the name of the local ID that points to the logical unit that PSF Direct uses on the Windows NT server.

Because there may be several PSF Direct host receivers on an NT workstation and several NT workstations in an SNA network, each PSF Direct host receiver must have a unique logical unit name.

Network Internals View of an SNA Network

While the application view illustrates the relationship of an SNA network to the applications that use it, the network internals view aids in understanding the components of an SNA network and how they must be configured.

Network internals view for a 37xx Communications Controller:

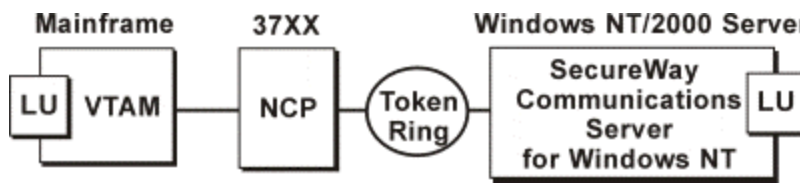

Network internals view for a Local 3172 Communications Controller:



Network internals view for a Local 3174 Communications Controller:



Network internals view for a Remote 3174 Communications Controller:

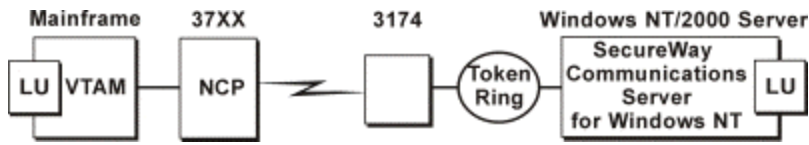

The network internals view illustrates that many components comprise an SNA network. Most of the components have detailed configuration requirements. Many of those requirements are described within the five configuration topics.

First, however, it is important to understand that several network components have configuration parameters whose values are related to configuration parameters for other network components. These interrelated parameters must be configured consistently to make end-to-end communication possible.

Several figures follow. They illustrate some of the key interrelationships among configuration parameters for SNA network components.

Key Configuration Parameter Interrelationships

The following image illustrates the interrelationships required when defining logical unit (LU) names:

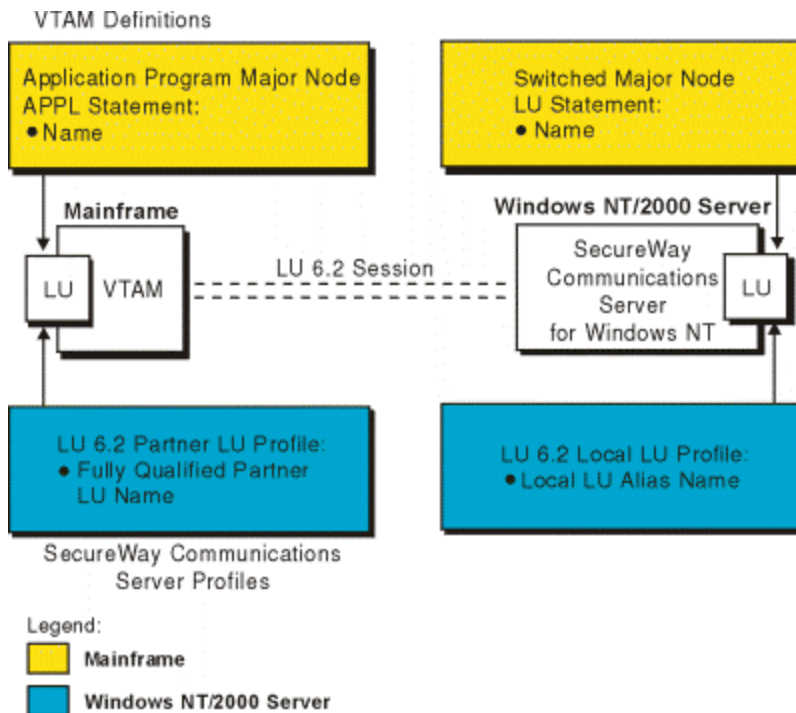

The following image illustrates the interrelationships required when defining the local address of the logical unit provided by SecureWay Communications Server for NT:

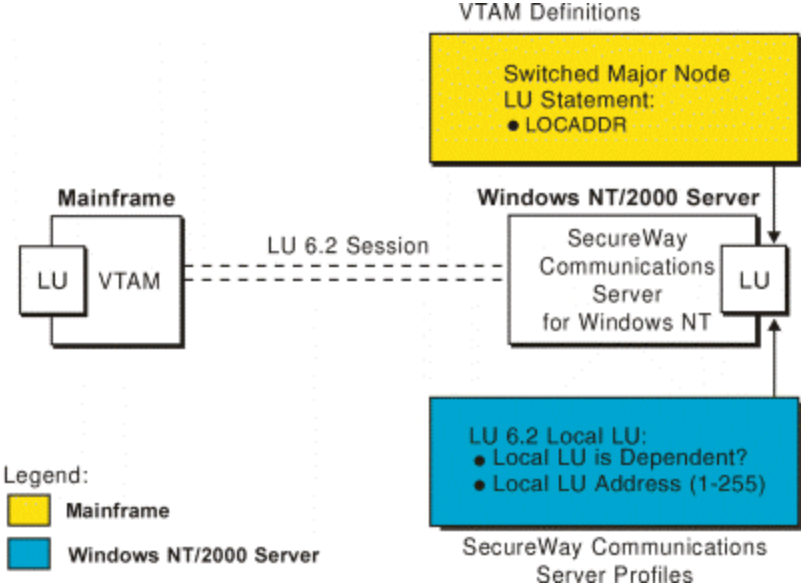

The following image illustrates the interrelationships required when defining session characteristics:

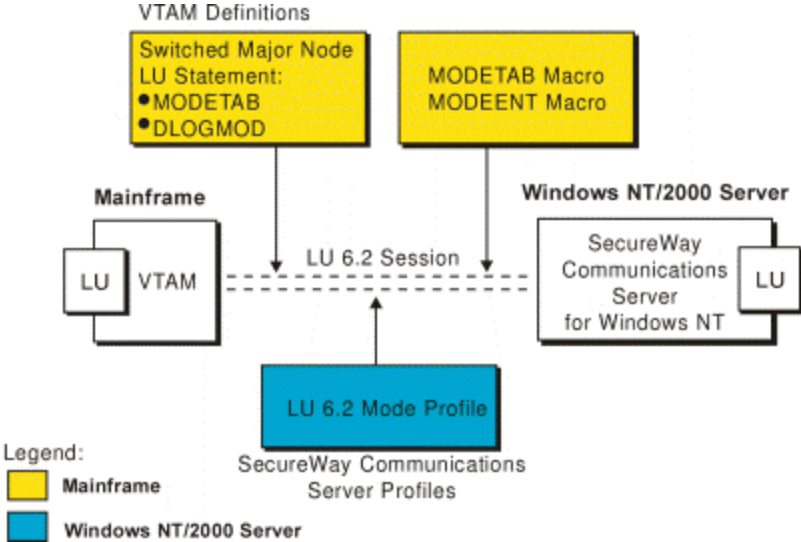

The following image illustrates the interrelationships required when defining the name of the physical unit/control point provided by SecureWay Communications Server for NT:

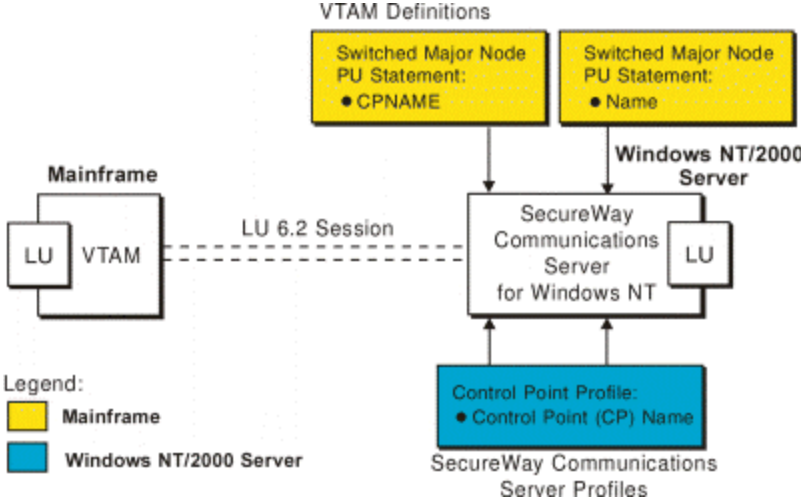

The following image illustrates the interrelationships required when defining the token-ring addresses used in the 37xx configuration:

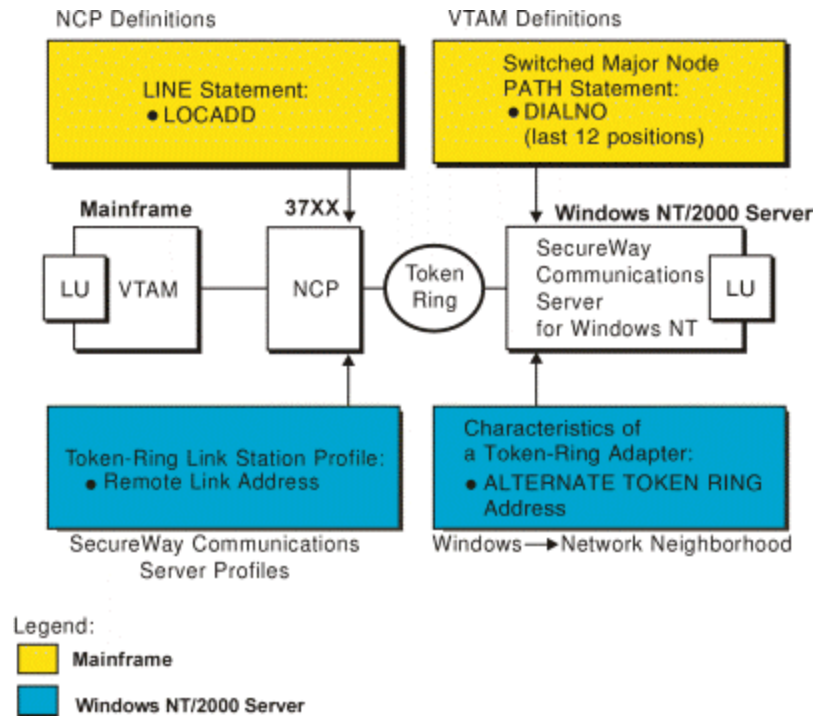

The following image illustrates the interrelationships required when defining the token-ring addresses used in the Local 3172 configuration:

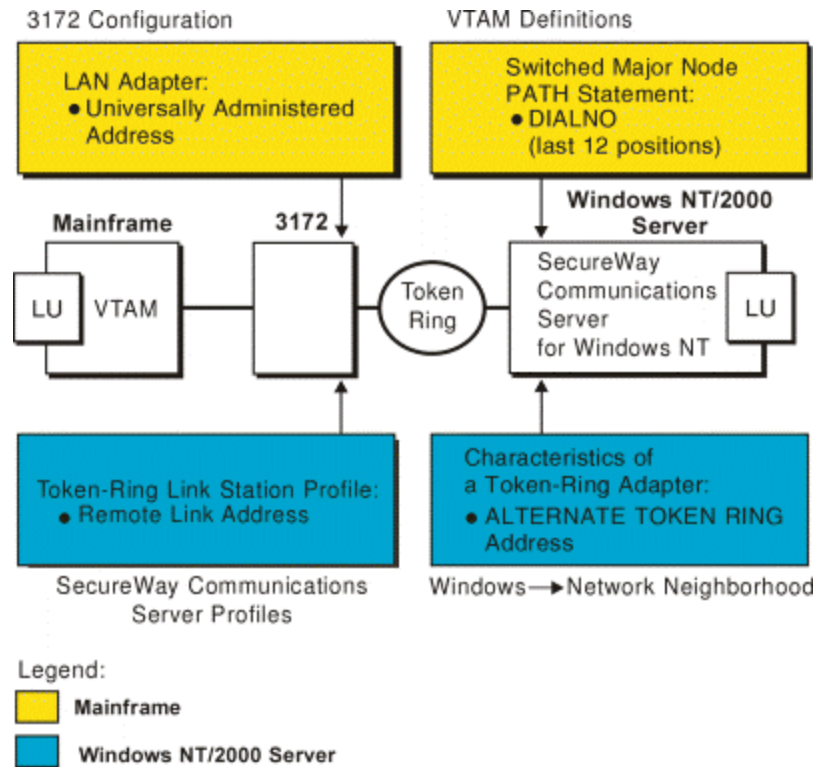

The following image illustrates the interrelationships required when defining the token-ring addresses used in either the Local or the Remote 3172 configuration:

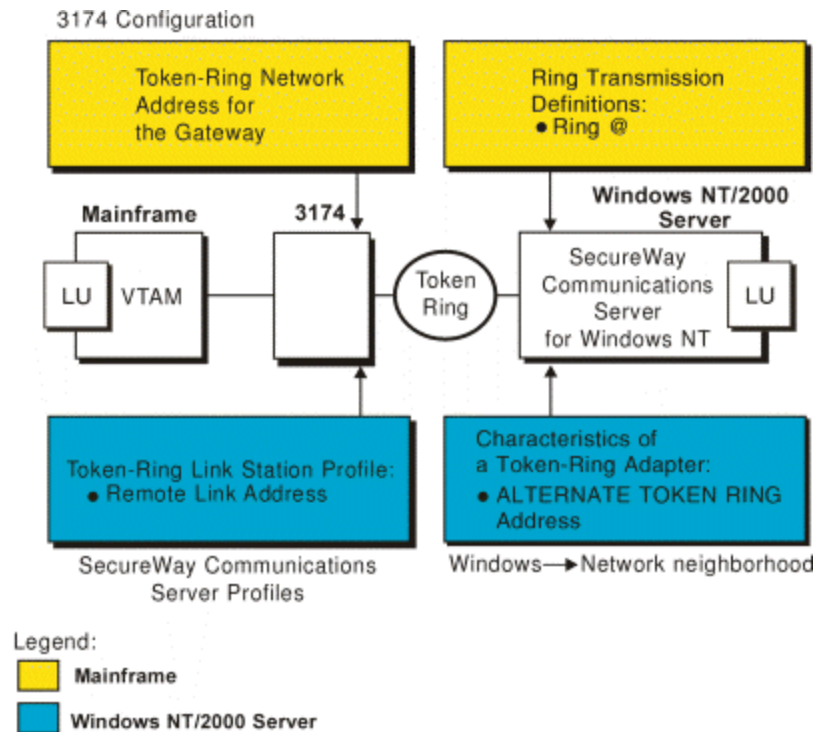

Preconfiguration Decisions for All PSF Direct Examples

Note that for each configuration example you must perform the following tasks, which are defined within the configuration examples:

- [Defining devices for IBM SecureWay Communications Server and Infoprint Windows NT](#)
- [Using an alternate token-ring address for a Windows NT server](#)
- [Decide whether to define a dependent or an independent LU](#)
- [Configuring an LU 6.2 Partner LU on your Infoprint Windows NT Server](#)
- [Enable SNA API Clients on your Infoprint Windows NT server](#)

Defining Devices for IBM SecureWay Communications Server and Infoprint Windows NT

Devices must be defined for both Communications Server and Infoprint Windows NT so that the token-ring (or ethernet) card can be used to carry the SNA data from the PSF host program. Usually, a device must be made available once, and then remains available, even after Windows NT is shutdown and restarted. For each configuration example, you accomplish this task through Device Configuration, the second of the IBM SecureWay Communications Server for NT configuration profiles provided in each example.

Using an Alternate Token-Ring Address for a Windows NT Server

A token-ring address, often called a **MAC address**, has 12 hexadecimal digits, for example, 10005AC8B0EA. Each device in a token-ring network must have a unique address. To facilitate unique token-ring addressing, every manufacturer assigns a distinct address called a **universal MAC address** to each token-ring adapter. By default, a token-ring adapter in a Windows NT server uses the token-ring address that the manufacturer assigned when the adapter was made. However, Windows NT systems allow you to define an **alternate token-ring address**, also called a **local MAC address**.

In some configurations, an alternate token-ring address might be necessary. For example, if the **DIALNO** operand is included in a VTAM switched major node **PATH** statement, an alternate token-ring address is generally required. The **DIALNO** operand accepts only digits in the 0-9 range; however, most universal MAC addresses (assigned by the manufacturer) include at least one digit in the A-F range. In these instances, it might be necessary to use an alternate token-ring address that does not contain any digits in the A-F range. Generally, the first four digits of alternate token-ring addresses must be 4000.

To assign an alternate token-ring address to an token-ring adapter in a Windows NT or Windows 2000 server, you must refer to the operating system online help because different levels of the operating systems can vary.

If you want to assign an alternate token-ring address to a token-ring adapter on a Microsoft Windows NT Version 4.00.1381 system, for example, use the following procedure:

1. Specify the **My Computer-->Control Panel-->Network** path.
2. Select the **Adapters** tab.
3. Highlight the token-ring adapter and click the **Properties...** button.
4. From the **IBM Auto 16/4 Token-Ring Adapter Card Setup** pop-up, specify the local MAC address in the Network Address field.
5. Shut down and reboot your Infoprint Windows NT server so the new address can take effect.

Decide whether to Define a Dependent or an Independent LU

You will usually add an LU 6.2 Local LU profile for each logical unit used by PSF Direct, whether the logical unit is dependent or independent. Whenever possible, you should define an independent LU, because they are easier to manage. With a dependent LU, you must assign a session ID and track its NAU address.

A dependent LU requires the following from the **Communications Server SNA Node Configuration** window:

1. Click the plus sign (+) next to **Host Resources** to access **Host Connections**.
2. Highlight **Host Connections** and select the **Create** option.
3. Fill in all the values on the **Define a LAN Connection** window, then specify **OK**.
4. At the **Do you wish to create and assign new LUs to this connection?** pop-up dialog, specify **YES**.
5. Fill in the **Host LU Definition** window, specifying a **base LU name** value.

An independent LU requires the following from the **Communications Server SNA Node Configuration** window:

1. Select and define **Peer Connections**, while leaving **Host Resources** empty.
2. Select the **Local LU 6.2 LUs** option under the **CPI-C and APPC** heading.
3. Specify the **Define a Local LU 6.2 (Basic)** window, leaving the **Dependent LU** unchecked.
4. Specify the **Define a Local LU 6.2 (Advanced)** window.

Configuring an LU 6.2 Partner LU on your Infoprint Windows NT Server

You must configure an LU 6.2 Partner LU profile for each logical unit used by a host PSF program. Some IBM SecureWay Communications Server for NT documentation indicates that an LU 6.2 Partner LU profile is not required if the local LU is an independent logical unit. However, because the logical unit used by the host PSF program does not support parallel sessions, IBM SecureWay Communications Server for NT requires an LU 6.2 profile in all PSF Direct configurations.

Enable SNA API Clients on your Infoprint Microsoft NT Server

Access these panels by clicking on the plus (+) sign next to **Client Resources** and right-clicking on the **SNA API Clients** box. Then, follow the instructions provided below:

1. From the **SNA Clients** panel, check the **Enable SNA API Client Services** box.
2. Single-click on the **OK** button at the bottom of the screen to save these specifications to the appropriate *.acg file, where * is the first-qualifier name of the .acg file that you named on the **Welcome to Communications Server Configuration!** window.

Local or Remote 37xx Token-Ring

The following displays a view of a local or remote 37xx Token-Ring configuration:

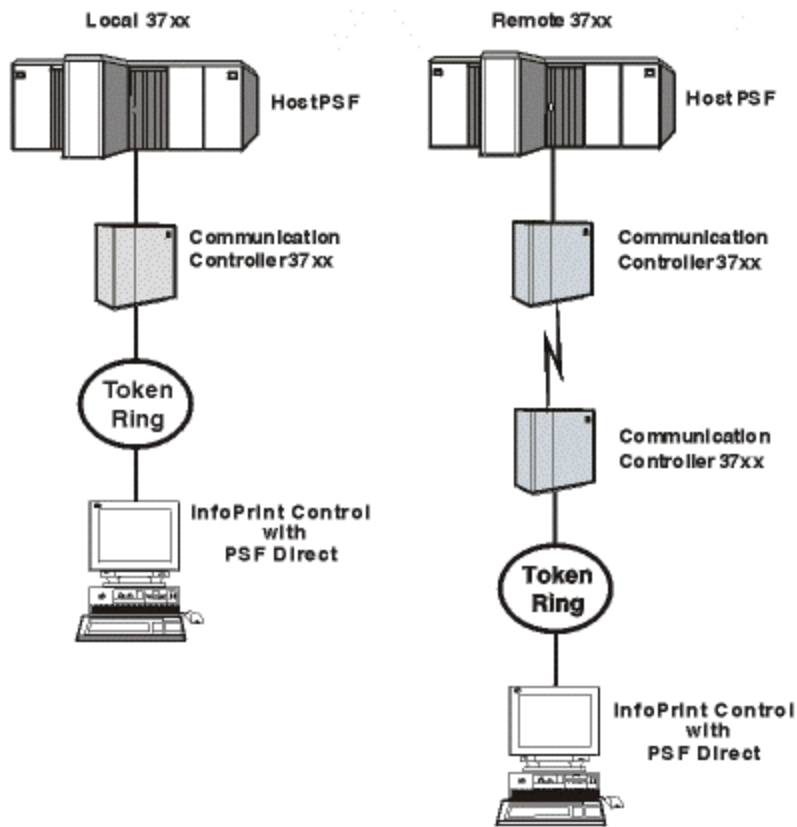

This configuration example defines an Independent LU.

For an explanation of pertinent configuration parameters, see [Guidelines for Configuring Local or Remote 37xx Token-Ring](#).

37xx Host Configuration Examples

The following local 37xx Token-Ring example uses MVS and JES2. For an explanation of pertinent configuration parameters, see [Guidelines for Configuring Local or Remote 37xx Token-Ring](#).

- [JES2 Initialization Statement Example](#)
- [JES2 External Writer Procedure Example](#)
- [VTAM Start Option List \(ATCSTRxx\) Example](#)
- [VTAM Configuration List \(ATCCONnn\) Example](#)
- [VTAM Application Program Major Node and Application Program Example](#)
- [VTAM Mode Table and Entry Example](#)
- [VTAM Switched Major Node Example](#)
- [Network Control Program \(NCP\) Definitions Example](#)
- [Accessing the Communications Server for NT Profiles](#)
- [Communications Server for NT Configuration Profile Examples](#)

JES2 Initialization Statement Example

For more information about this example, refer to the guidelines for [Specifying the JES2 Initialization Statement](#).

```
PRT618
CLASS=Y, MARKS=YES, START=NO, MODE=FSS, FSS=WTRES600, X
PRMODE=(LINE, PAGE), UCS=0
```

JES2 External Writer Procedure Example

For more information about this example, refer to the guidelines for [Configuring the Host PSF Printer](#).

```
//WTRES600 PROC
//*
//STEP01 EXEC PGM=APSPPIEP, REGION=4096K
//*
//STEPLIB DD DSN=SYSTEM.PSF.V220.LINKLIB, DISP=SHR
//*
//JOBHDR OUTPUT PAGEDEF=A06462, /* JOB HEADER PAGEDEF */
```



```

//          FORMDEF=A10110          /* JOB HEADER FORMDEF    */
//JOBTLR OUTPUT PAGEDEF=A06462,    /* JOB TRAILER PAGEDEF  */
//          FORMDEF=A10110          /* JOB TRAILER FORMDEF  */
//DSHDR OUTPUT PAGEDEF=A06462,     /* DATA SET HEADER PAGEDEF*/
//          FORMDEF=A10110          /* DATA SET HEADER FORMDEF*/
//MSGDS OUTPUT PAGEDEF=A06462,     /* MESSAGE DATASET PAGEDEF*/
//          FORMDEF=A10110          /* MESSAGE DATASET FORMDEF*/
//*
//FONT01 DD DSN=SYS1.FONTLIB,DISP=SHR
//OLAY01 DD DSN=SYS1.OVERLIB,DISP=SHR
//PSEG01 DD DSN=SYS1.PSEGLIB,DISP=SHR
//FDEF01 DD DSN=SYS1.FDEFLIB,DISP=SHR
//PDEF01 DD DSN=SYS1.PDEFLIB,DISP=SHR
//*
//PRT618 PRINTDEV FONTDD=*.FONT01, /* FONT LIBRARY DD      */
//          OVLYDD=*.OLAY01,        /* OVERLAY LIBRARY DD   */
//          PSEGDD=*.PSEG01,        /* SEGMENT LIBRARY DD   */
//          PDEFDD=*.OLAY01,        /* PAGEDEF LIBRARY DD   */
//          FDEFDD=*.OLAY01,        /* FORMDEF LIBRARY DD   */
//          JOBHDR=*.JOBHDR,         /* JOB HEADER DD        */
//          JOBTLR=*.JOBTLR,        /* JOB TRAILER DD       */
//          DSHDR=*.DSHDR,          /* DATA SET HEADER DD  */
//          MESSAGE=*.MSGDS,        /* MESSAGE DATA DD     */
//          PAGEDEF=A06462,         /* DEFAULT PAGEDEF     */
//          FORMDEF=A10110,         /* DEFAULT FORMDEF     */
//          CHARS=(gt10,GC15,GB10,GR10,), /* DEFAULT FONT SET*/
//          PIMSG=YES,              /* ACCUMULATE DATA SET MESSAGES*/
//          SETUP=FORMS,            /* ISSUE FORMS SETUP MESSAGES */
//          MGMTMODE=OUTAVAIL,      /* START WHEN OUTPUT AVAILABLE */
//          DISCINTV=60,            /* DISCONNECT INTERVAL -- SECS */

```

```

//      LOGMODE=IBM3820T,          /* LOGON MODE TABLE ENTRY */
//      APPLID=FSAES618,          /* APPLICATION PGM NAME */
//      LUNAME=PSFDC4LU          /* LOGICAL UNIT NAME */

//PRT618 ENDCNTL

```

VTAM Start Option List (ATCSTRxx) Example

For more information about this example, refer to the guidelines for [Specifying the VTAM Start Option List \(ATCSTRxx\)](#).

```

CONFIG=00,          ATCCON MEMBER OF VTAMLST      x
NETID=USIBMBQ,     NETWORK IDENTIFIER                x
SSCPID=1,          SSCP IDENTIFIER                x
:

```

VTAM Configuration List (ATCCONnn) Example

For more information about this example, refer to the guidelines for [Specifying the VTAM Configuration List \(ATCCONnn\)](#).

```

PSFAPPLS,          x
:

```

VTAM Application Program Major Node and Application Program Example

For more information about this example, refer to the guidelines for [Specifying the VTAM Application Program Major Node and Application Program](#) .

```
PSFAPPLS,      VBUILD TYPE=APPL                x
FSAES618,      APPL AUTH=ACQ,EAS=1,SONSCIP=YES  x
:
```

VTAM Mode Table and Entry Example

For more information about this example, refer to the guidelines for [Specifying the VTAM Mode Table and Entry](#) .

```
MODEIBM      MODETAB                                x
IBM3820T     MODEENT LOGMODE=IBM3820T,FMPROF=X'13',TSPROF=X'07',
:             PRIPROC=X'B0',SECPROT=X'B0',COMPROT=X'B0B1'      x
             PSERVIC=X'06020000000000000000200'              x
             PSNDPAC=X'10',SRCVPAC=X'10',SSNDPAC=X'00'        x
             RUSIZES=X'8787'
```

VTAM Switched Major Node Example

For more information about this example, refer to the guidelines for [VTAM Switched Major Node Example](#).

```
:
PSFDC3SW  VBUILD TYPE=SWNET
*
DEVTESTB  PU      ADDR=04 ,                ADDRESS REQUIRED, BUT IGNORED      x
          CPNAME=DEVTESTB ,              CONTROL POINT NAME                x
:
          MAXOUT=7 ,                      LINK LEVEL WINDOW                  x
          MODETAB=MODEIBM ,              LOGON MODE TABLE                  x
          DLOGMOD=IBM3820T ,            LOGON MODE TABLE ENTRY            x
          VPACING=0 ,                    NO PACING TO BOUNDARY NODE
*
PSFDLU    LU      LOCADDR=0 ,             INDEPENDENT LU
```

Network Control Program (NCP) Definitions Example

For more information about this example, refer to the guidelines for [Specifying the Network Control Program \(NCP\) Definitions](#) .

```
:
G31P   GROUP  ECLTYPE=PHYSICAL,          PHYSICAL GROUP           x
        ISTATUS=ACTIVE,                 INITIAL STATUS            x
LN31   LINE   ADDRESS=(1088,FULL),       LINE NUM AND DATA TRANS x
        LOCADD=400023101088,           TOKEN RING ADDRESS FOR   x
:      MAXTSL=1033,                     MAXIMUM BYTES OF DATA   x
        PORTADD=1,                      PORT ADDRESS              x
        DLOGMOD=IBM3820T,               BUFFER CAPACITY          x
PU31   PU
LU31   LU    ISTATUS=INACTIVE,          INITIAL STATUS
*
G31L   GROUP  ECLTYPE=LOGICAL,          LOGICAL GROUP            x
        ISTATUS=ACTIVE,                 INITIAL STATUS            x
        AUTOGEN=8,                      # OF LINE AND PU PAIRS  x
        CALL=INOUT,                     CALL IN OR OUT           x
        PHYPORT=1                       CORRELATES WITH PORTADD
*
```

Accessing the Communications Server for NT Profiles

Use the following procedure to access the IBM SecureWay Communications Server for NT applications described in the [What is Communications Server for NT?](#) topic.

Note that the following presumes you have dragged the icons for **SNA Node Configuration** and **SNA Node Operations** to your desktop after they were created at installation.

1. From your NT desktop view, double-click on the **SNA Node Configuration** icon that resides on your desktop:

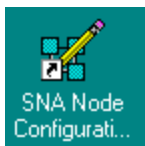

2. At the **Welcome to Communications Server Configuration!** pop-up window, select the **New** button (for a new configuration) and click on the **Next>** button.
3. Check the **Advanced** box, which causes the display to turn to grey (displayed below) and click the **Finish** button.

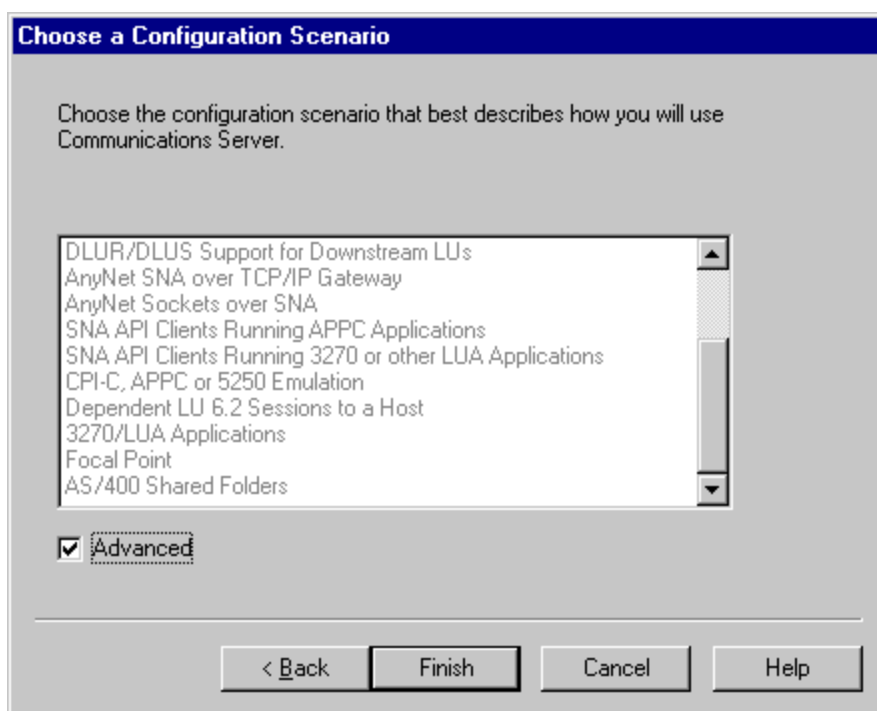

4. From the **Communications Server SNA Node Configuration** window (displayed below), you are ready to begin configuring your system for PSF Direct.

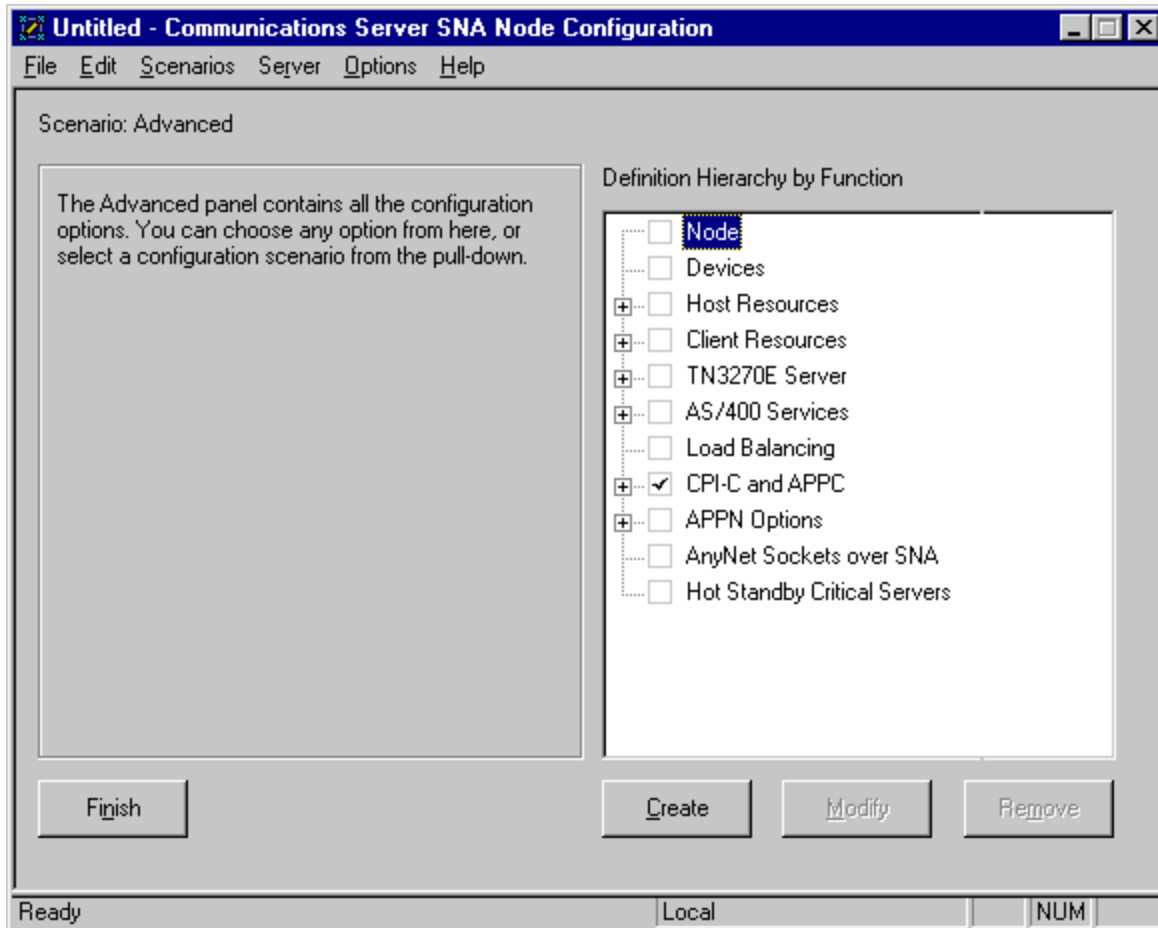

Communications Server for NT Configuration Profile Examples

From the preceding display of the **Communications Server SNA Node Configuration** window, there are eight configuration steps that you must complete. The following examples provide images with the appropriate examples filled in.

37xx Node Setup

You access this panel by right-clicking on the checked **Node** box of the **Communications Server SNA Node Configuration** window (displayed below) and selecting the **Create** option.

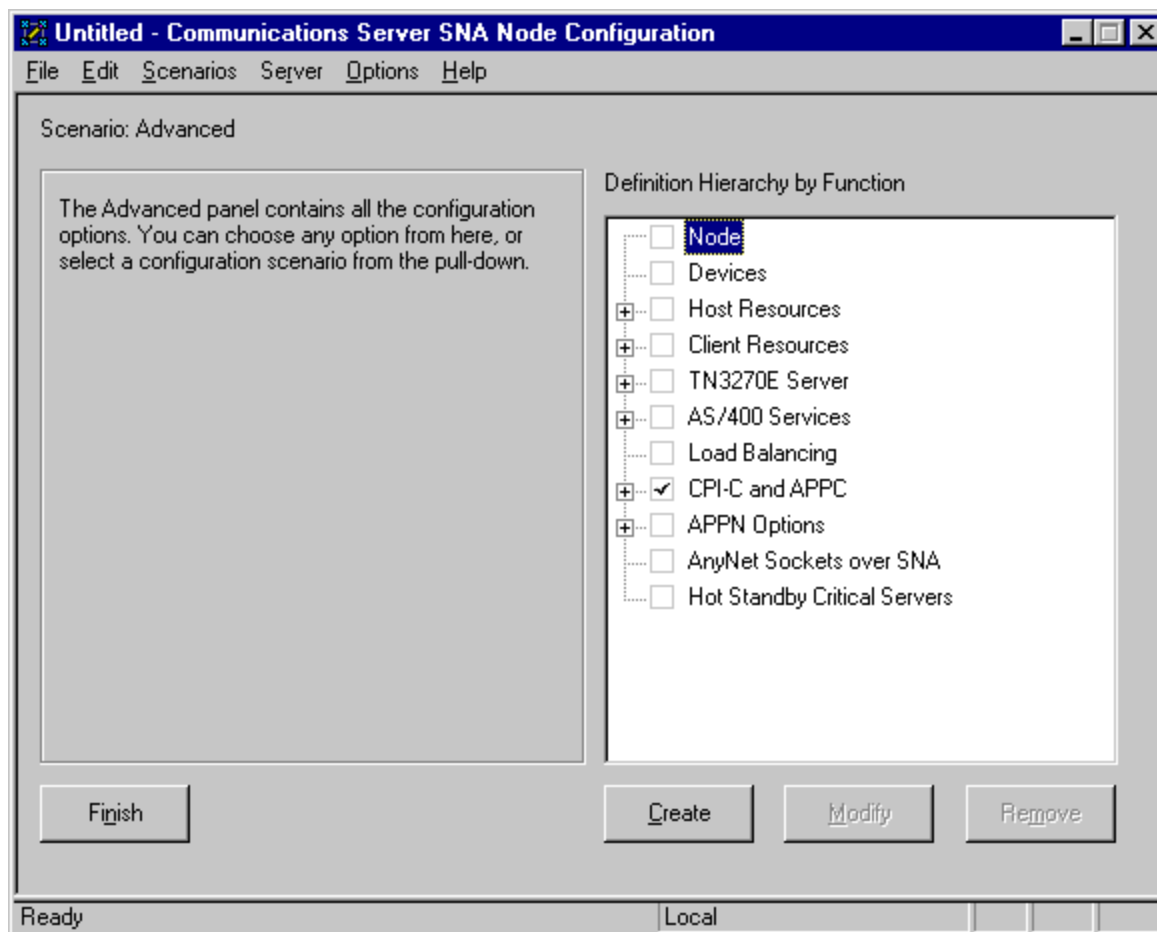

For more information about this configuration view, refer to the guidelines for [37xx Node setup - Basic Configuration](#).

Basic Configuration

The image shows a software configuration window titled "Define the Node". It has three tabs: "Basic", "Advanced", and "DLU Requester". The "Basic" tab is selected. The window is divided into three main sections:

- Control Point (CP):** Contains two input fields for the "Fully qualified CP name": "USIBMBQ" and "DEVTESTB", separated by a period. Below them is a "CP alias" field containing "DEVTESTB".
- Local Node ID:** Contains two input fields: "Block ID" with the value "05D" and "Physical Unit ID" with the value "C021B".
- Node Type:** Contains three radio button options: "End Node" (which is selected), "Network Node", and "Branch Extender Node".

At the bottom of the window are three buttons: "OK", "Cancel", and "Apply".

For more information about this configuration view, refer to the guidelines for [37xx Node setup - Advanced Configuration](#).

Note that the **Advanced Configuration** panel takes the Communication Server for NT defaults and is shown for reference only.

Advanced Configuration

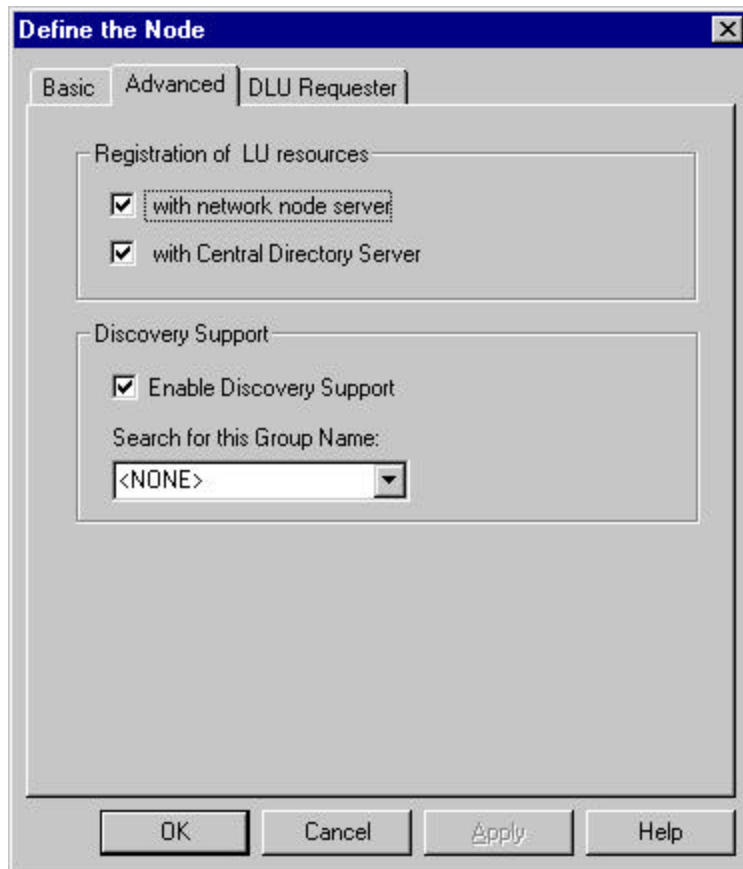

Note that the **DLU Requester** panel takes the Communication Server for NT defaults and is shown for reference only.

DLU Requester

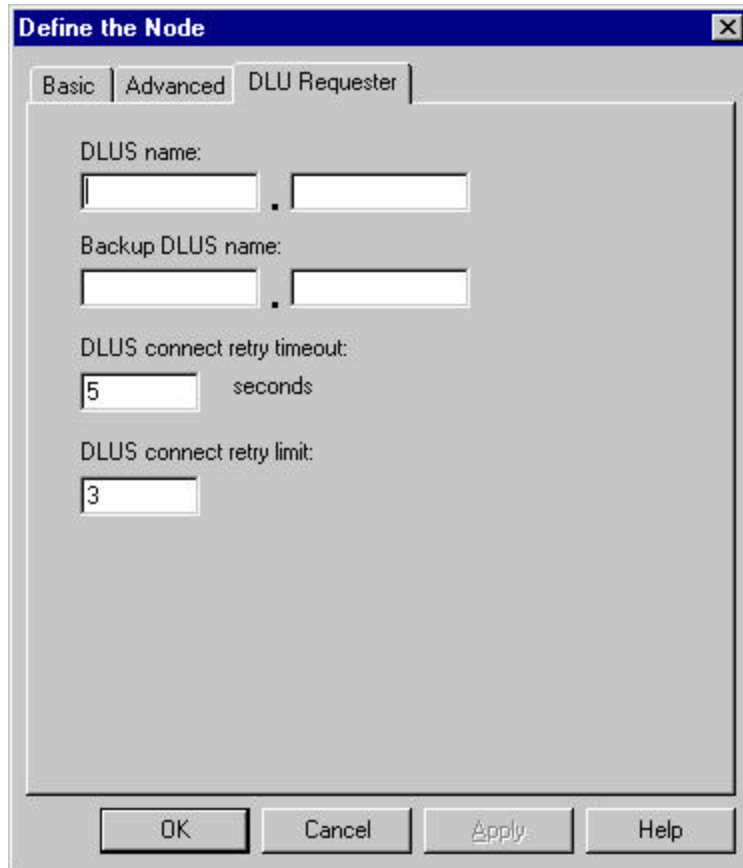

The screenshot shows a dialog box titled "Define the Node" with a close button (X) in the top right corner. It has three tabs: "Basic", "Advanced", and "DLU Requester", with the "DLU Requester" tab selected. The dialog contains the following fields and controls:

- DLUS name:** Two text input boxes separated by a period (.)
- Backup DLUS name:** Two text input boxes separated by a period (.)
- DLUS connect retry timeout:** A text input box containing the number "5" followed by the text "seconds".
- DLUS connect retry limit:** A text input box containing the number "3".

At the bottom of the dialog, there are four buttons: "OK", "Cancel", "Apply", and "Help".

Single-click on the **OK** button at the bottom of the screen to save these specifications to the appropriate *.acg file.

37xx Device Configuration

You access these panels by right-clicking on the **Devices** box of the **Communications Server SNA Node Configuration** window (displayed below) and selecting the **Create** option.

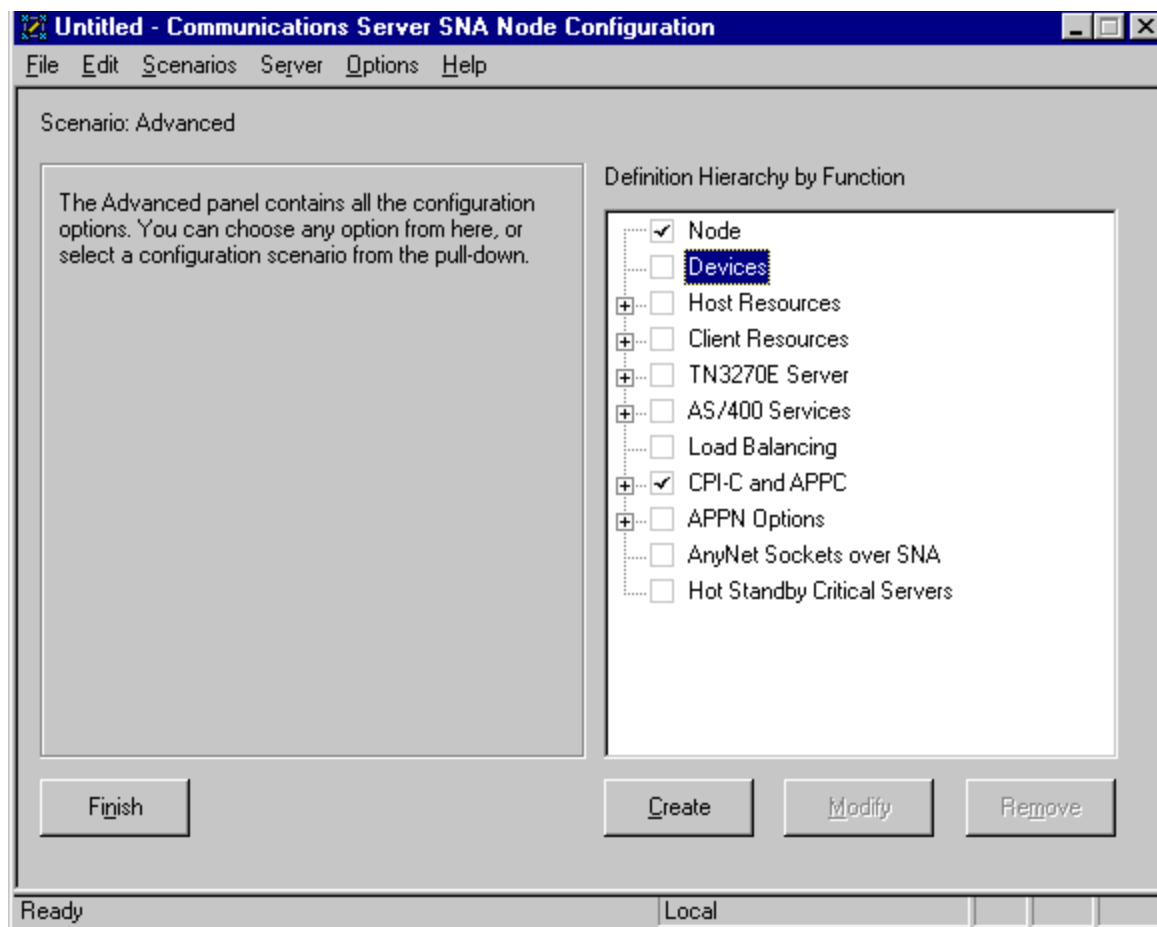

In the **Device Type** pop-up window, select LAN:

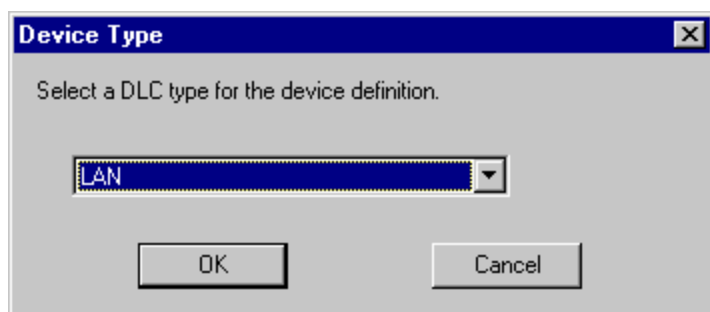

Click **OK**.

On the **Define a LAN Device** window, note that you may have more than one adapter defined at your installation. Ensure that you select the proper token-ring LAN adapter (depending upon your installation, you may see both token-ring and ethernet adapters).

For more information about this configuration view, refer to the guidelines for [Basic Device Configuration](#).

Basic Configuration

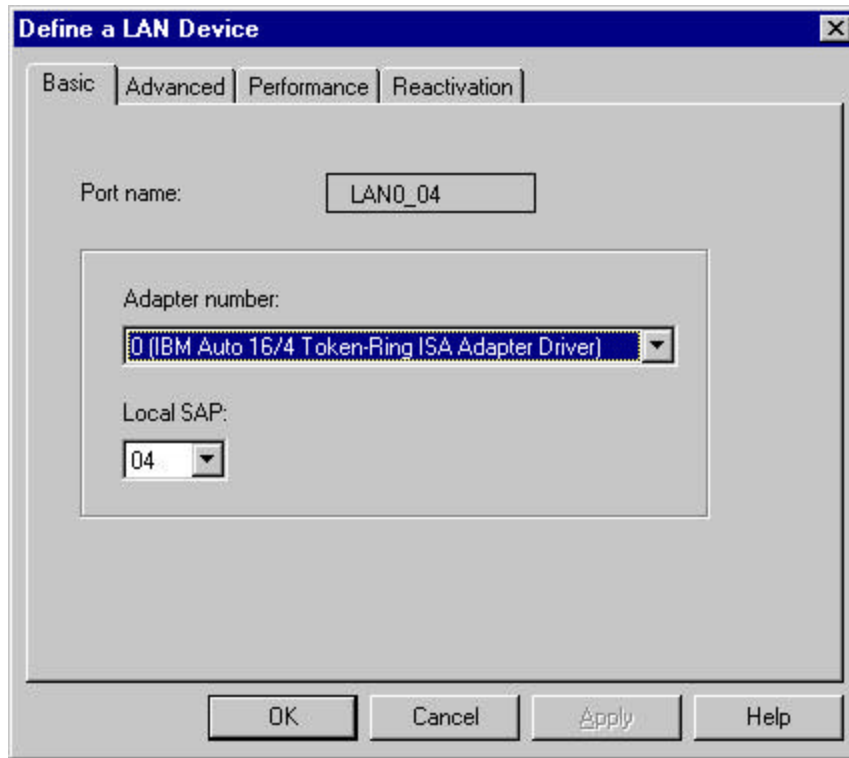

For more information about this configuration view, refer to the guidelines for [Advanced Device Configuration](#).

Advanced Configuration

The image shows a Windows-style dialog box titled "Define a LAN Device". It has four tabs: "Basic", "Advanced", "Performance", and "Reactivation". The "Advanced" tab is selected. The dialog contains the following configuration options:

- XID retry interval: 8 seconds (dropdown menu)
- XID retry limit: 5 (dropdown menu)
- Test retry interval: 30 seconds (dropdown menu)
- Test retry limit: 3 (dropdown menu)
- Receive window count: 7 (dropdown menu)
- Maximum PIU size: 65535 (text input field)

At the bottom of the dialog are four buttons: "OK", "Cancel", "Apply", and "Help".

For more information about this configuration view, refer to the guidelines for [Performance Device Configuration](#).

Note that the **Performance Configuration** panel takes the Communication Server for NT defaults and is shown for reference only.

Performance Configuration

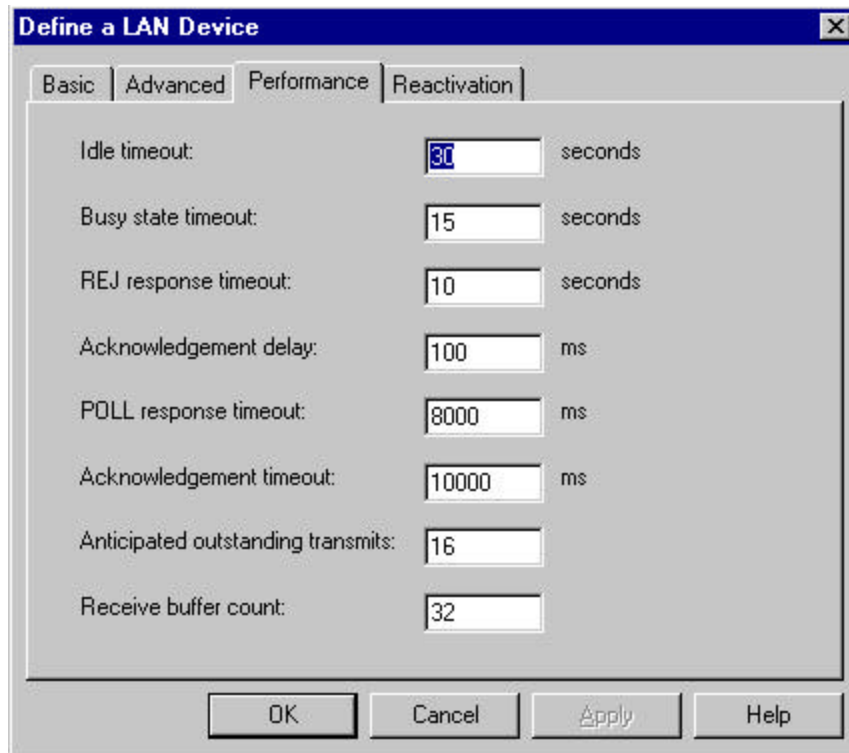

The screenshot shows a dialog box titled "Define a LAN Device" with a close button (X) in the top right corner. The dialog has four tabs: "Basic", "Advanced", "Performance", and "Reactivation". The "Performance" tab is selected. The dialog contains several configuration fields:

Parameter	Value	Unit
Idle timeout:	30	seconds
Busy state timeout:	15	seconds
REJ response timeout:	10	seconds
Acknowledgement delay:	100	ms
POLL response timeout:	8000	ms
Acknowledgement timeout:	10000	ms
Anticipated outstanding transmits:	16	
Receive buffer count:	32	

At the bottom of the dialog, there are four buttons: "OK", "Cancel", "Apply", and "Help".

For more information about this configuration view, refer to the guidelines for [Reactivation Device Configuration](#).

Note that the **Reactivation Configuration** panel takes the Communication Server for NT defaults and is shown for reference only.

Reactivation Configuration

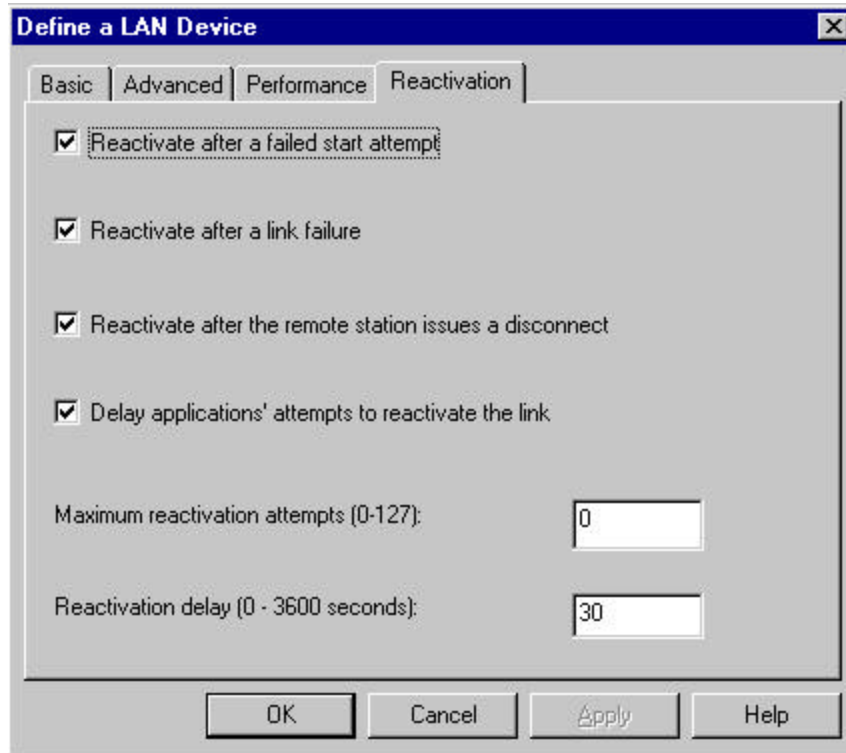

Single-click on the **OK** button at the bottom of the screen to save these specifications to the appropriate *.acg file.

Enabling SNA API Clients for Local 37xx

For more information about this example, refer to [Enabling SNA API Clients on your Infoprint Microsoft NT Server](#).

You access these panels by clicking on the **Client Resources** box and then right-clicking on the **SNA API Clients** box (displayed below) and selecting the **Create** option.

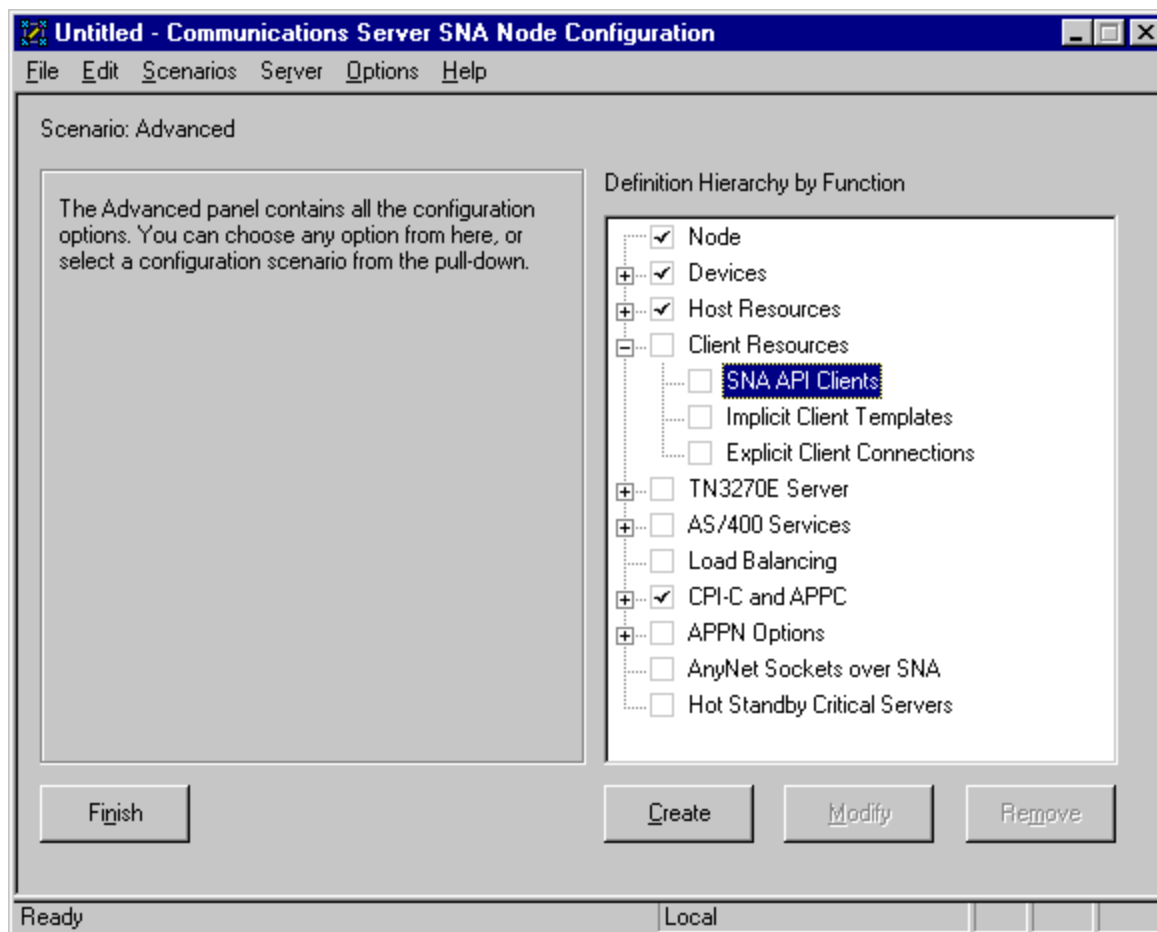

From the **SNA Clients** panel, check the **Enable SNA API Client Services** box.

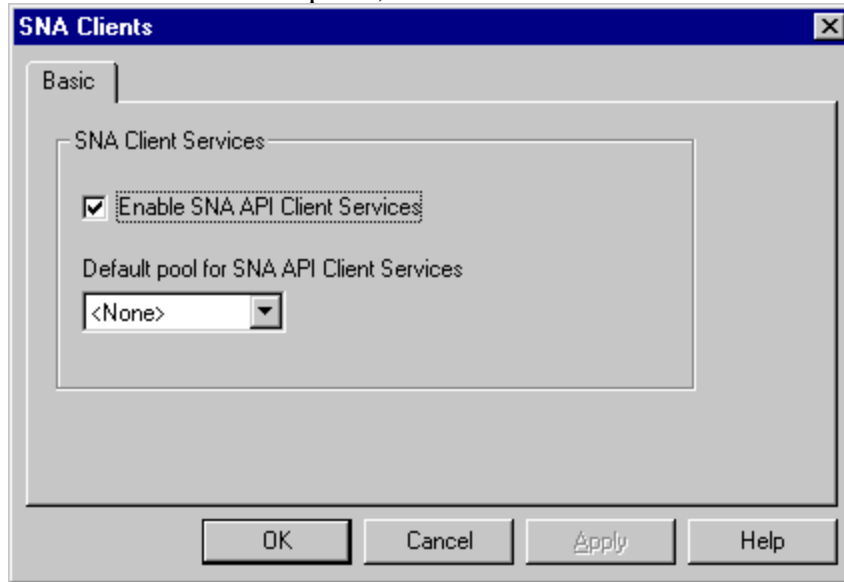

Single-click on the **OK** button at the bottom of the screen to save these specifications to the appropriate *.acg file.

37xx Peer Connection Configuration

You access the panels on the following pages by clicking on the **CPI-C and APPC** box and then right-clicking on the **Peer Connections** box (displayed below) and selecting the **Create** option.

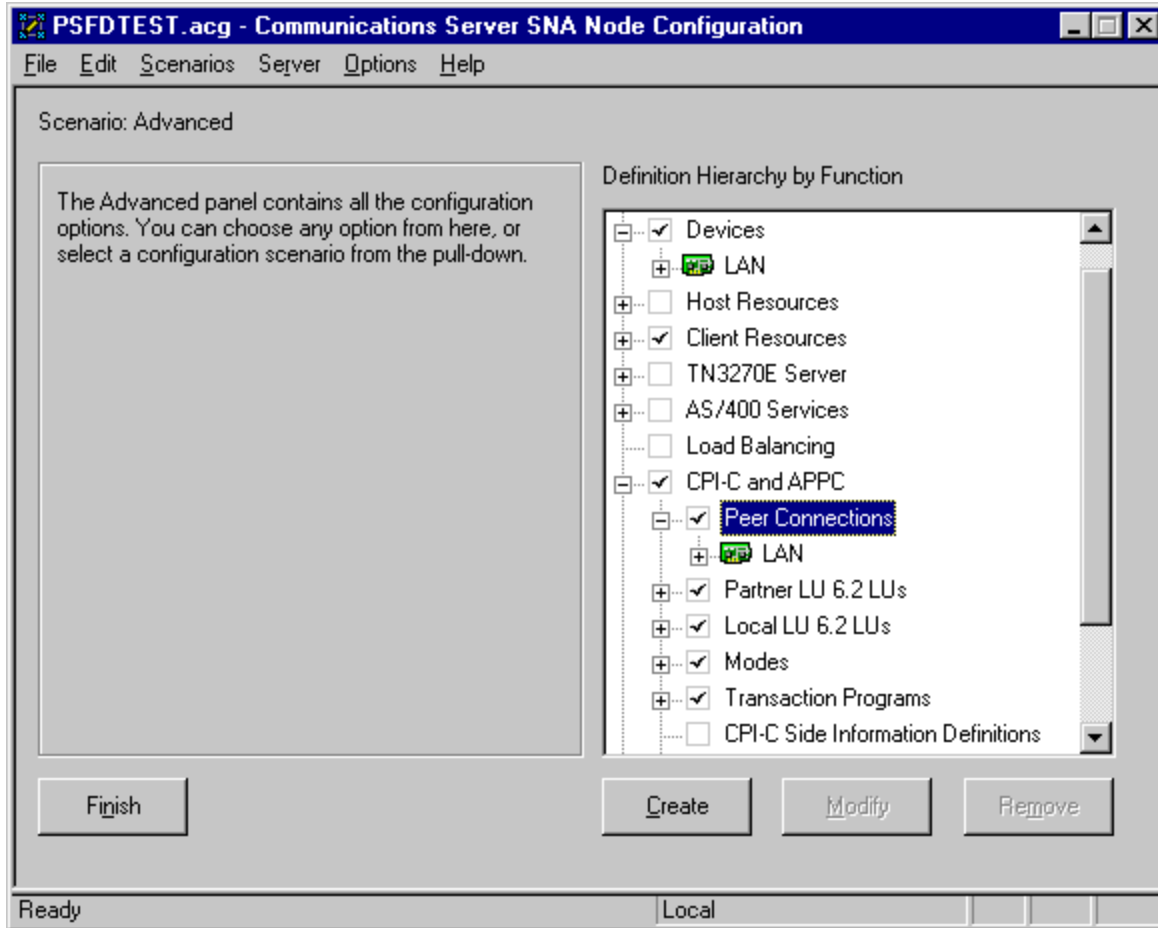

For more information about this configuration view, refer to the guidelines for [Peer Connection - Basic Configuration](#). Note that the **Link station name** field contents will vary, depending upon the number of links at your installation.

Basic Configuration

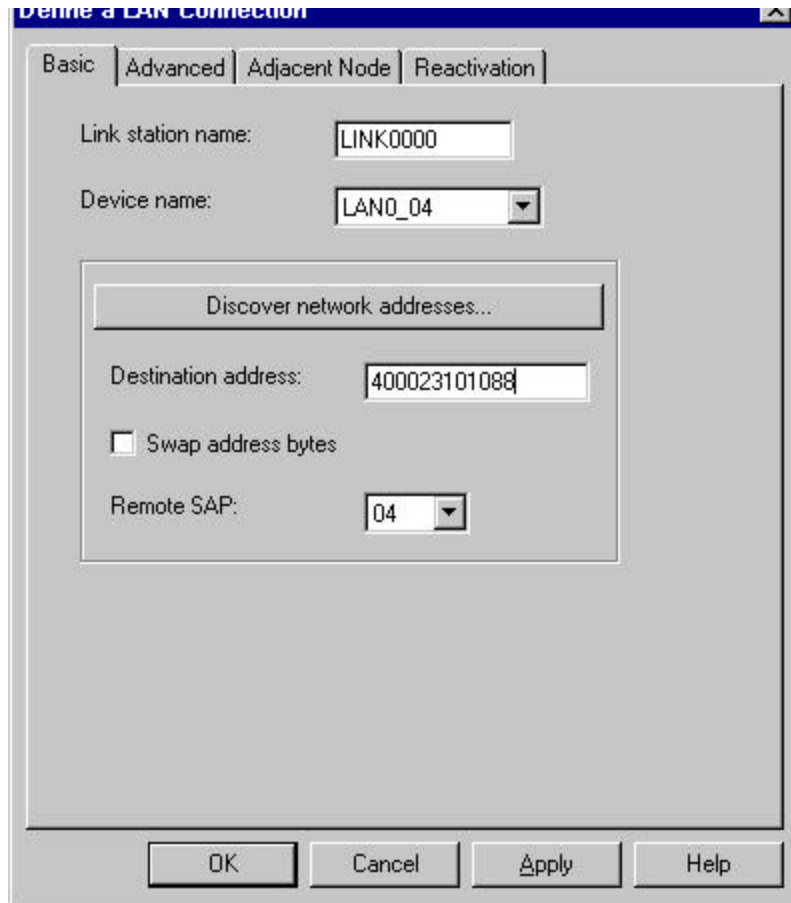

The image shows a screenshot of a software dialog box titled "Define a LAN Connection". The dialog has four tabs: "Basic", "Advanced", "Adjacent Node", and "Reactivation". The "Basic" tab is selected. The fields are as follows:

- Link station name: LINK0000
- Device name: LAN0_04 (dropdown menu)
- Discover network addresses... (button)
- Destination address: 400023101088
- Swap address bytes
- Remote SAP: 04 (dropdown menu)

At the bottom of the dialog are four buttons: OK, Cancel, Apply, and Help.

For more information about this configuration view, refer to the guidelines for [Peer Connection - Advanced Configuration](#).

Note that the **Advanced Configuration** panel takes the Communication Server for NT defaults and is shown for reference only.

Advanced Configuration

The screenshot shows a dialog box titled "Define a LAN Connection" with four tabs: "Basic", "Advanced", "Adjacent Node", and "Reactivation". The "Advanced" tab is selected. The dialog contains several checkboxes and text input fields. The "Activate link at start" checkbox is checked. Other checkboxes include "HPR support", "APPN support", "Auto-activate support", "Link to preferred NN server", "Solicit SSCP sessions", "Use PU name as CP name", "Encryption mandatory", "Compression requested", and "Branch extender connection". The "PU name" field contains "LINK0000". The "Local Node ID" section has "Block ID" set to "05D" and "Physical Unit ID" set to "C021B". At the bottom are "OK", "Cancel", and "Apply" buttons.

Option	Value
Activate link at start	<input checked="" type="checkbox"/>
HPR support	<input type="checkbox"/>
APPN support	<input checked="" type="checkbox"/>
Auto-activate support	<input type="checkbox"/>
Link to preferred NN server	<input type="checkbox"/>
Solicit SSCP sessions	<input type="checkbox"/>
PU name	LINK0000
Use PU name as CP name	<input type="checkbox"/>
Encryption mandatory	<input type="checkbox"/>
Compression requested	<input type="checkbox"/>
Branch extender connection	<input type="checkbox"/>
Local Node ID - Block ID	05D
Local Node ID - Physical Unit ID	C021B

Note that the **Adjacent Node Configuration** panel takes the Communication Server for NT defaults and is shown for reference only.

Adjacent Node Configuration

The image shows a Windows-style dialog box titled "Define a LAN Connection" with a close button (X) in the top right corner. The dialog has four tabs: "Basic", "Advanced", "Adjacent Node", and "Reactivation". The "Adjacent Node" tab is currently selected. The main area of the dialog contains the following fields:

- Adjacent CP name:** Two empty text input boxes separated by a period.
- Adjacent CP type:** A dropdown menu with "Learn" selected.
- TG number:** A dropdown menu with "0" selected.
- Adjacent node ID:** A container box containing two sub-fields:
 - Block ID:** A text input box containing "000".
 - Physical Unit ID:** A text input box containing "00000".

At the bottom of the dialog, there are four buttons: "OK", "Cancel", "Apply", and "Help".

Note that the **Reactivation Configuration** panel takes the Communication Server for NT defaults and is shown for reference only.

Reactivation Configuration

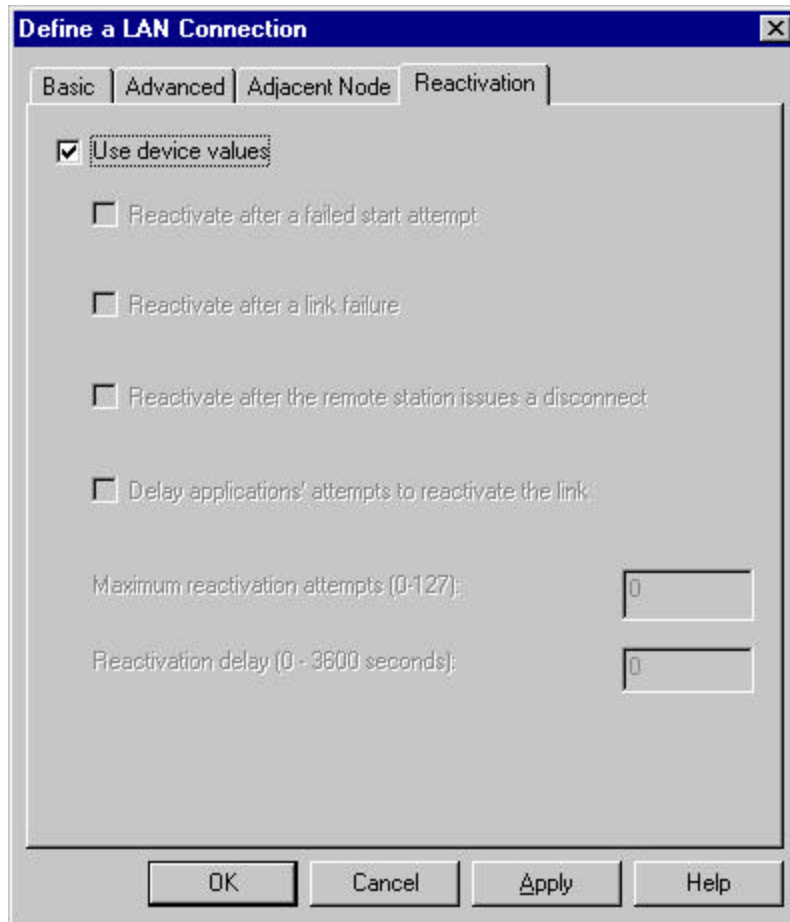

Note that after selecting the **OK** button, a pop-up window appears asking "Do you want to automatically route all APPC sessions over this connection?" You must reply **yes** before the configuration is accepted.

37xx Partner LU 6.2 Configuration

You access these panels by clicking on the checked **CPI-C and APPC** box of the **Communications Server SNA Node Configuration** window and then right-clicking on the **Partner LU 6.2 LUs** box (displayed below) and selecting the **Create** option.

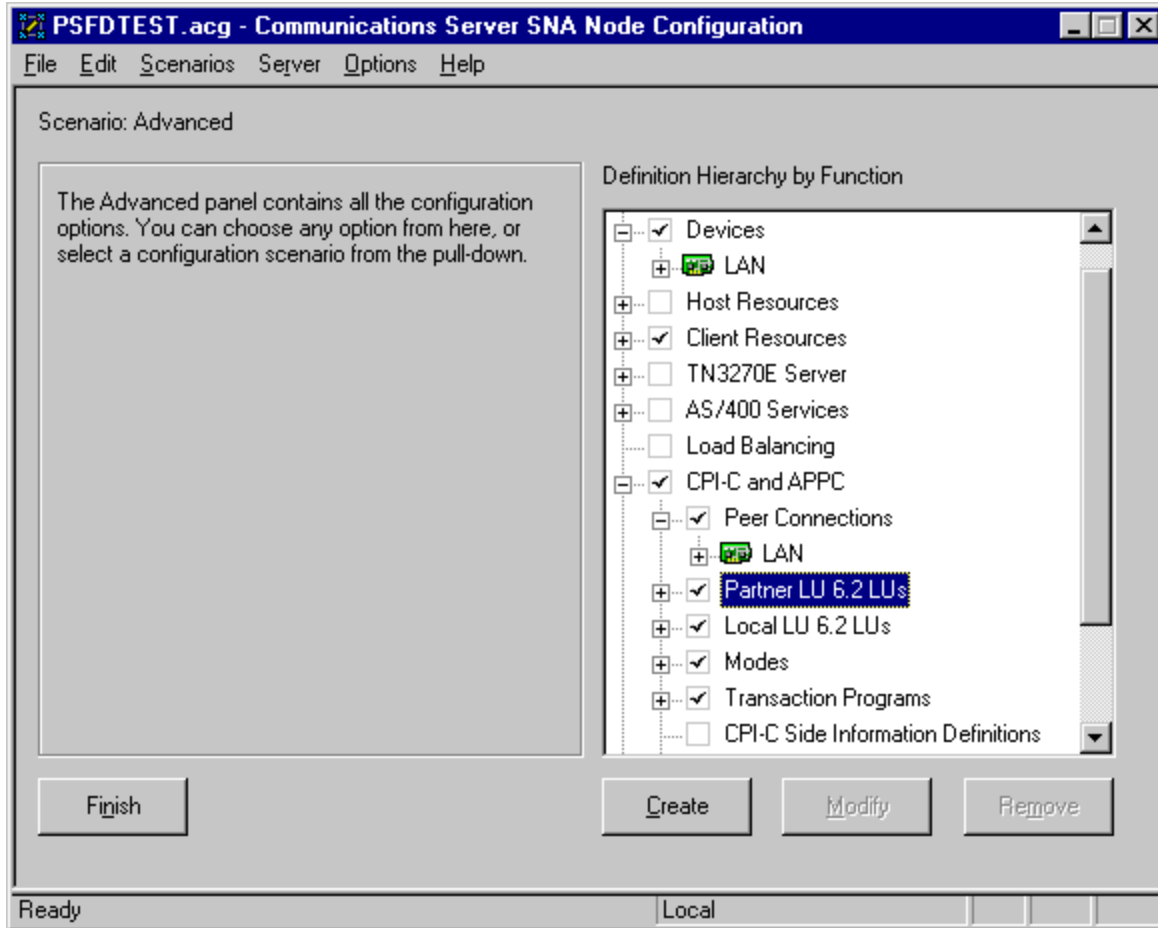

For more information about this configuration view, refer to the guidelines for [Partner LU 6.2 Basic Configuration](#). Note that neither panel takes the Communication Server for NT defaults.

Basic Configuration

The image shows a dialog box titled "Define a Partner LU 6.2" with a "Basic" tab selected. The "Advanced" tab is also visible. The "Partner LU name:" field contains "USIBMBQ" and "FSAES618". There is an unchecked checkbox for "Wildcard". The "Partner LU alias:" field contains "FSAES618". Under "Fully qualified CP name:", the "New" radio button is selected, with "USIBMBQ" and "DEVTESTB" in the adjacent fields. The "Existing" radio button is unselected, with an empty dropdown menu below it. At the bottom are "OK", "Cancel", and "Apply" buttons.

Define a Partner LU 6.2

Basic | Advanced

Partner LU name:
USIBMBQ . FSAES618

Wildcard

Partner LU alias:
FSAES618

Fully qualified CP name:

New
USIBMBQ . DEVTESTB

Existing
[Dropdown menu]

OK Cancel Apply

For more information about this configuration view, refer to the guidelines for [Partner LU 6.2 Advanced Configuration](#).

Advanced Configuration

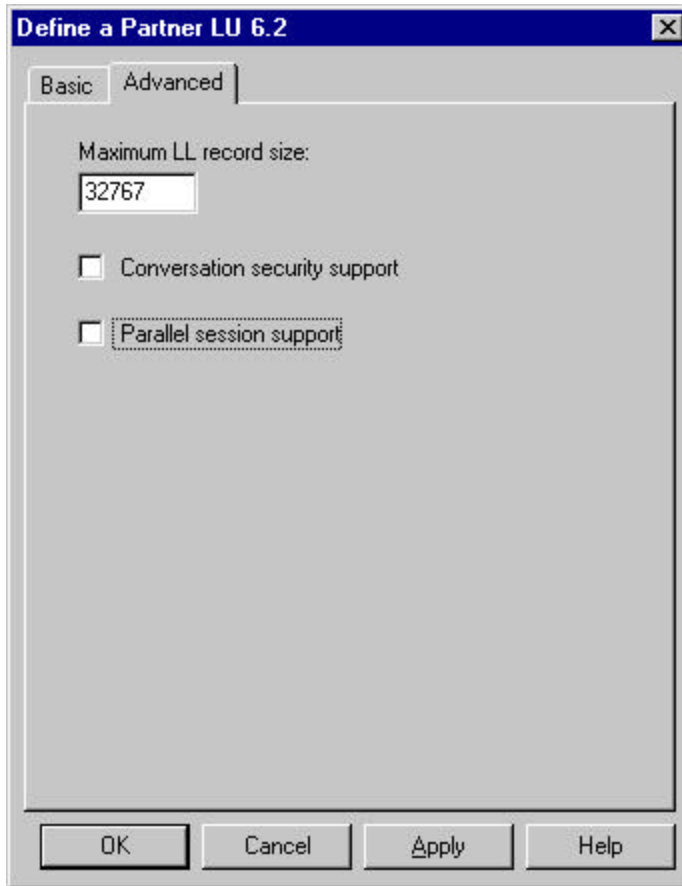

Single-click on the **OK** button at the bottom of the screen to save these specifications to the appropriate *.acg file.

37xx Local LU 6.2 Configuration

You access these panels by right-clicking on the **Local LU 6.2 LUs** box (displayed below) and selecting the **Create** option.

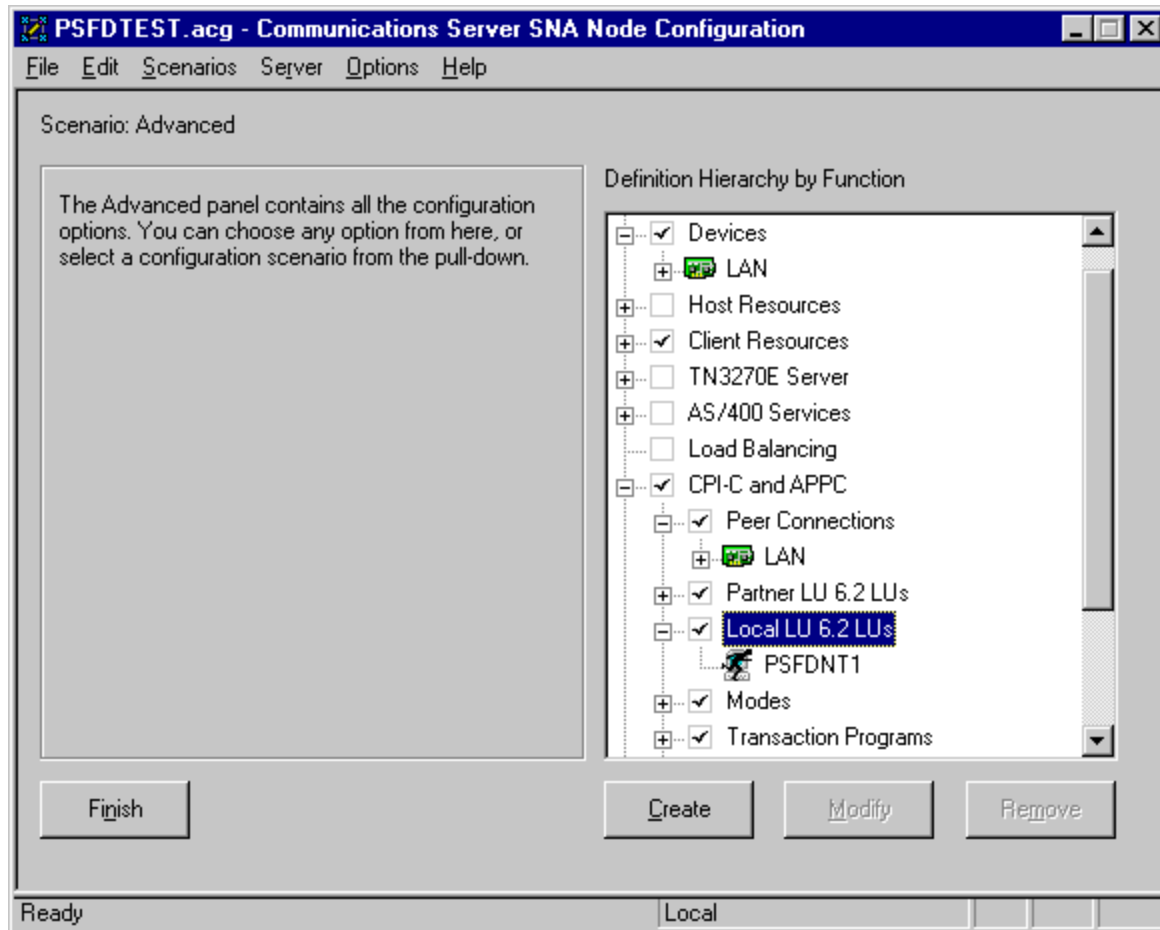

For more information about this configuration view, refer to the guidelines for [Local LU 6.2 Basic Configuration](#). Note that neither panel takes the Communication Server for NT defaults.

If you are configuring a Dependent LU, these panels cannot be used. If you require Dependent LUs, see [Decide whether to Define a Dependent or an Independent LU](#).

Basic Configuration

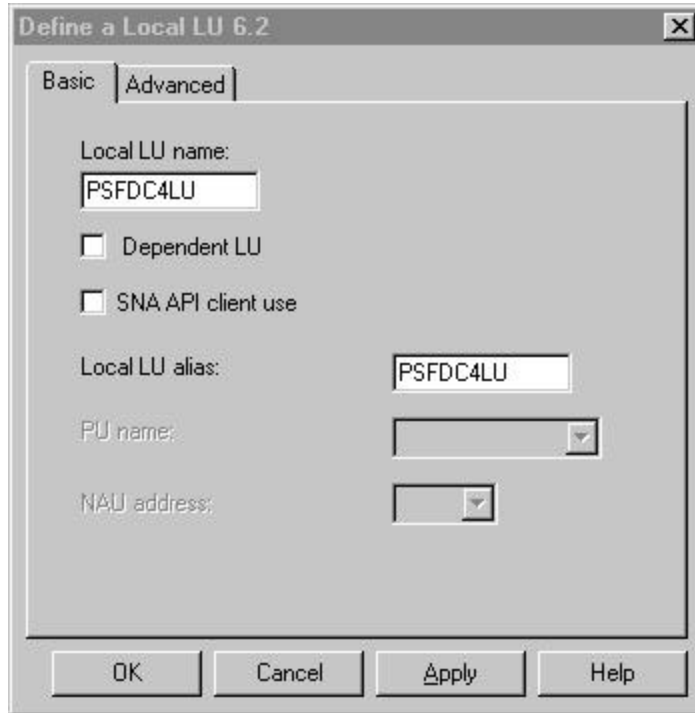

The image shows a Windows-style dialog box titled "Define a Local LU 6.2". It has two tabs: "Basic" (selected) and "Advanced". The "Basic" tab contains the following fields and controls:

- Local LU name:** A text input field containing "PSFDC4LU".
- Dependent LU:** An unchecked checkbox.
- SNA API client use:** An unchecked checkbox.
- Local LU alias:** A text input field containing "PSFDC4LU".
- PU name:** A dropdown menu.
- NAU address:** A dropdown menu.

At the bottom of the dialog box are four buttons: "OK", "Cancel", "Apply", and "Help".

For more information about this configuration view, refer to the guidelines for [Local LU 6.2 Advanced Configuration](#). Note that neither panel takes the Communication Server for NT defaults.

Note: The application program only supports 1 LU session at a time, but the SNA session can support more.

Advanced Configuration

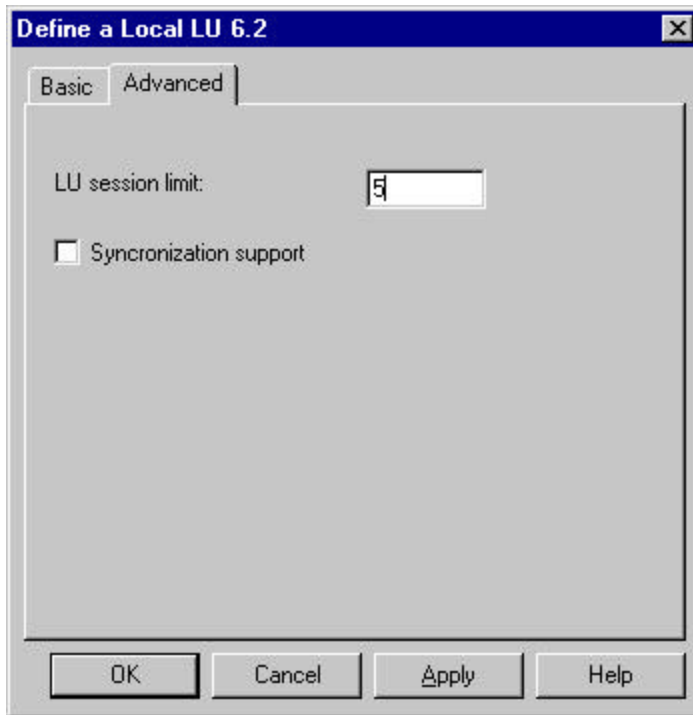

Single-click on the **OK** button at the bottom of the screen to save these specifications to the appropriate *.acg file.

37xx Mode Configuration

You access these panels by right-clicking on the **Modes** box (displayed below) and selecting the **Create** option.

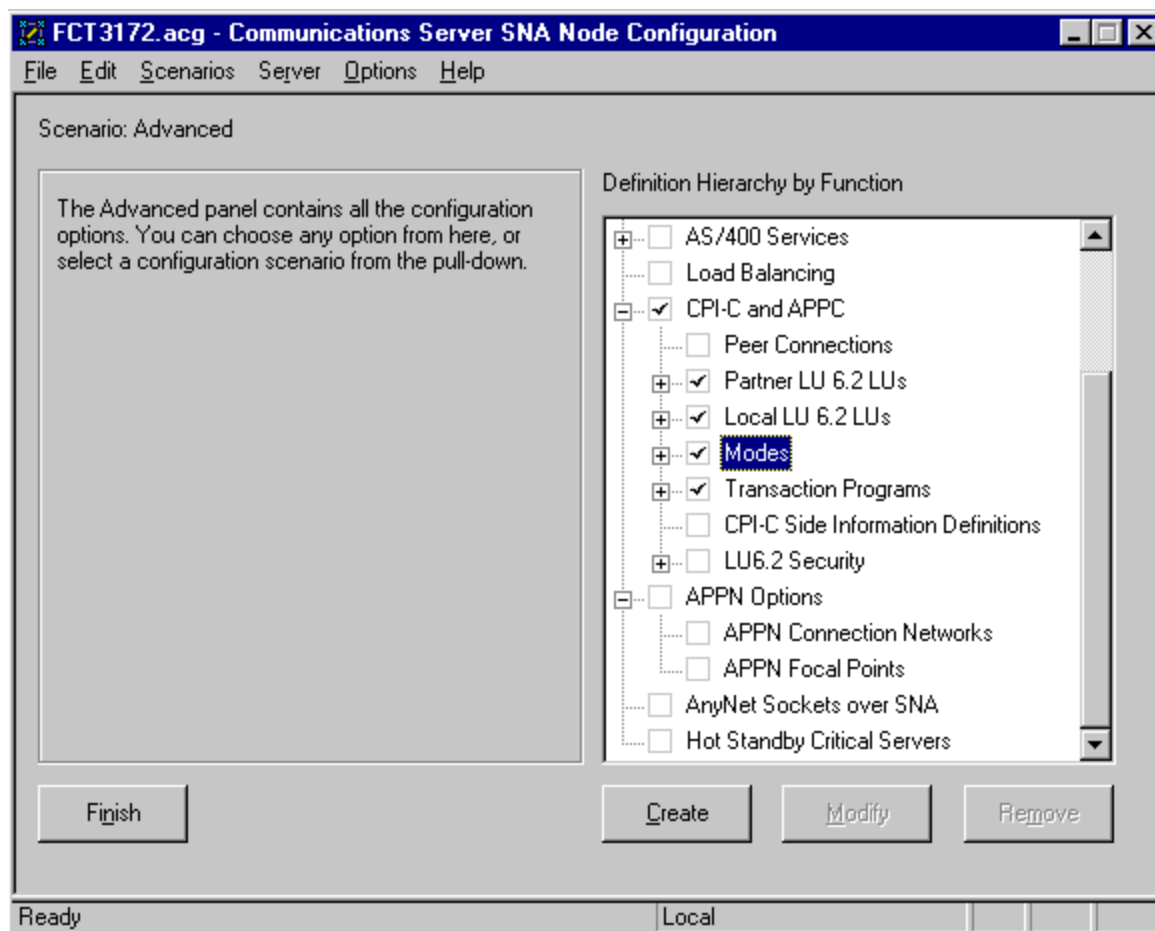

For more information about this configuration view, refer to the guidelines for [Configuring Modes Basic Configuration](#).

Basic Configuration

The image shows a dialog box titled "Define a Mode" with a close button (X) in the top right corner. The dialog has two tabs: "Basic" (selected) and "Advanced". Under the "Basic" tab, there are three input fields:

- "Mode name:" with the text "BLANK" entered.
- "PLU mode session limit:" with the value "8192" entered.
- "Minimum contention winner sessions:" with the value "4096" entered.

At the bottom of the dialog, there are four buttons: "OK", "Cancel", "Apply", and "Help".

For more information about this configuration view, refer to the guidelines for [Configuring Modes Advanced Configuration](#).

Note that if the default Maximum RU size displayed below does not work, you might have to change this field to '1024'.

Advanced Configuration

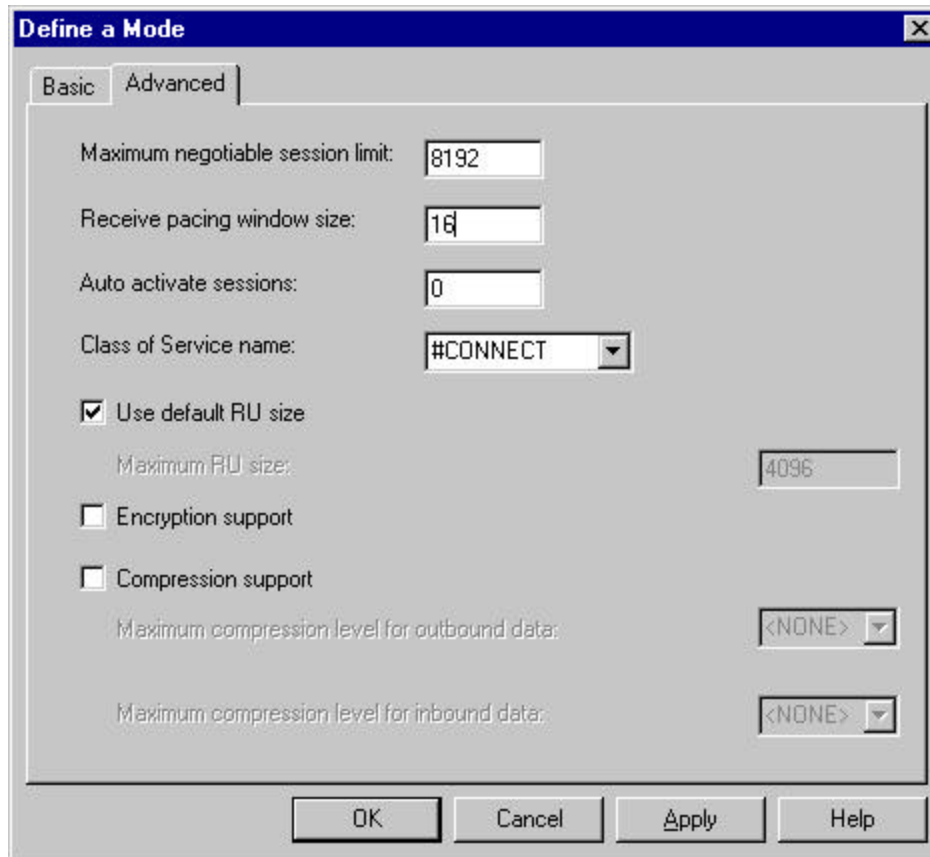

The screenshot shows a dialog box titled "Define a Mode" with a close button (X) in the top right corner. It has two tabs: "Basic" and "Advanced", with "Advanced" selected. The dialog contains the following fields and options:

- Maximum negotiable session limit: 8192
- Receive pacing window size: 16
- Auto activate sessions: 0
- Class of Service name: #CONNECT (dropdown menu)
- Use default RU size
 - Maximum RU size: 4096
- Encryption support
- Compression support
 - Maximum compression level for outbound data: <NONE> (dropdown menu)
 - Maximum compression level for inbound data: <NONE> (dropdown menu)

At the bottom of the dialog are four buttons: OK, Cancel, Apply, and Help.

Single-click on the **OK** button at the bottom of the screen to save these specifications to the appropriate *.acg file.

37xx Transaction Program Configuration

You access these panels by right-clicking on the **Transaction Programs** box (displayed below) and selecting the **Create** option.

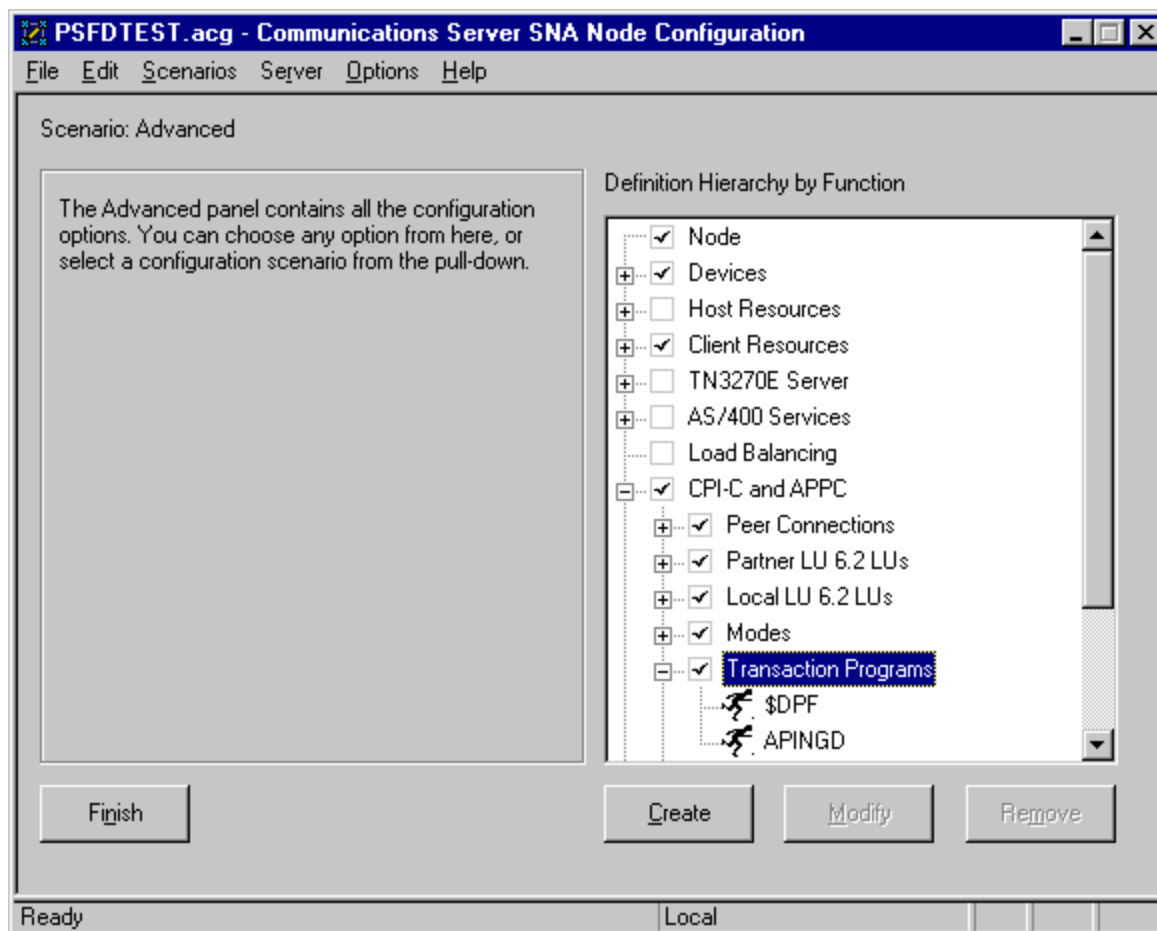

For more information about this configuration view, refer to the guidelines for [Transaction Program Basic Configuration](#).

Basic Configuration

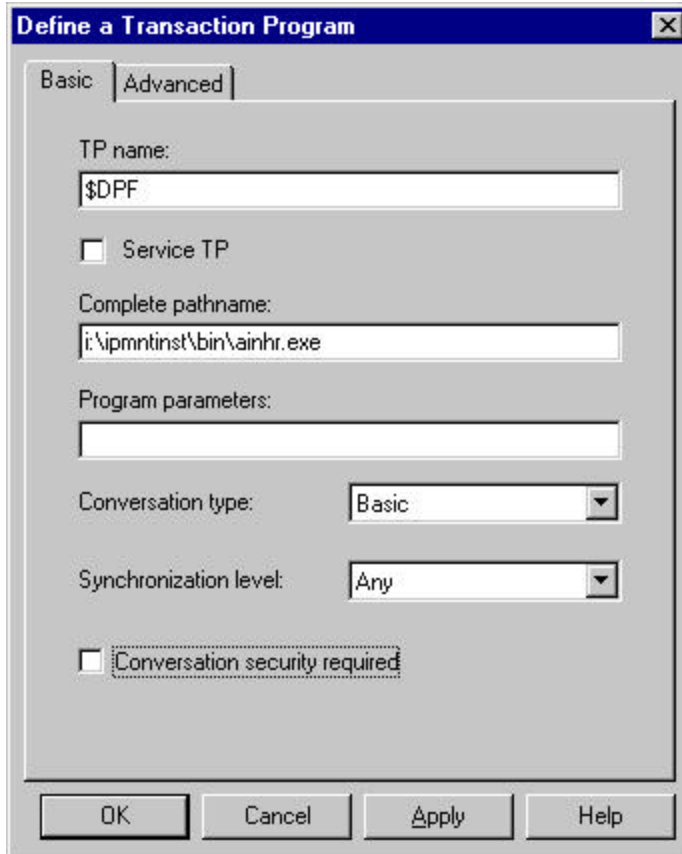

The image shows a Windows-style dialog box titled "Define a Transaction Program". It has two tabs: "Basic" (selected) and "Advanced". The "Basic" tab contains the following fields and controls:

- TP name:
- Service TP
- Complete pathname:
- Program parameters:
- Conversation type: (dropdown menu)
- Synchronization level: (dropdown menu)
- Conversation security required

At the bottom of the dialog box are four buttons: "OK", "Cancel", "Apply", and "Help".

For more information about this configuration view, refer to the guidelines for [Transaction Program Advanced Configuration](#).

Advanced Configuration

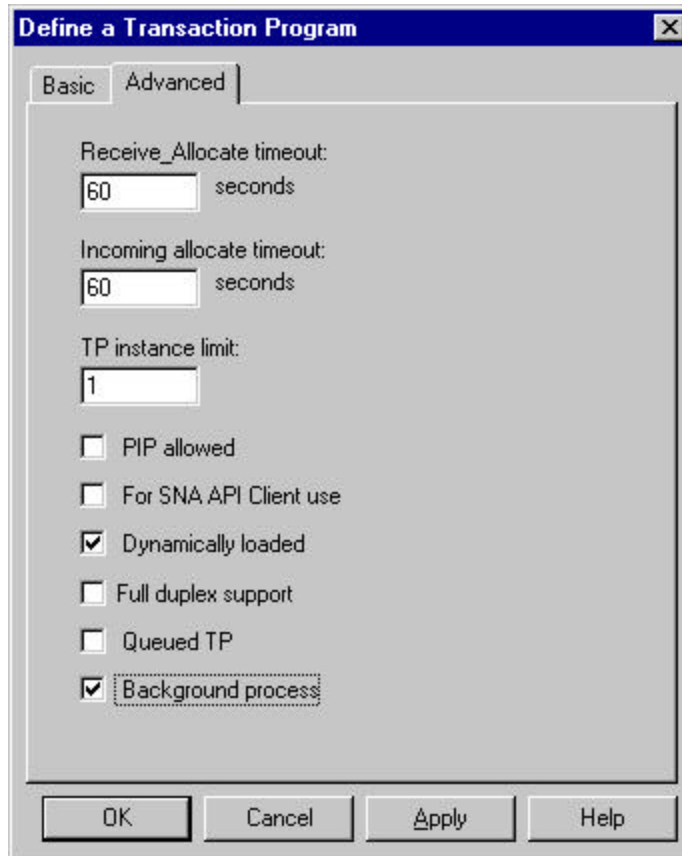

Single-click on the **OK** button at the bottom of the screen to save these specifications to the appropriate *.acg file.

Once you have completed creating this configuration, see [Starting an IBM SecureWay Communications Server for NT Configuration](#).

Guidelines for Configuring Local or Remote 37xx Token-Ring

The following provides guidance for implementing the examples displayed in [Local or Remote 37xx Configuration Worksheet Examples](#). Note that a subset of the example below displays the pertinent parameters and describing which of these require you to specify *variable_names* and which require a specific name or number, such as **MODETAB=MODEIBM** or **FMPROF=X'13'**.

An underlined value (such as WCONNECT) indicates that the value is a system default.

When [Specifying Communications Server for NT Configuration Profiles](#) (the last guidelines section cited in the list below), please note that Communications Server creates a *xxx.ACG* file (where *xxx* represents the file name you select at the **Welcome to Communications Server Configuration!** window when you first try to configure the node). This *xxx.ACG* file is located in the C:\IBMCS\private drive, where C is the drive where you choose to install IBM SecureWay Communications Server for NT. For users migrating from PSF Direct on an OS/2 operating system, this *xxx.ACG* file is the equivalent of the OS/2 Communications Manager Communications Server *xxx.NDF* file.

These guidelines consist of the following topics:

- [Local or Remote 37xx Host Configuration Information](#)
- [Specifying Communications Server for NT Configuration Profiles](#)

Local or Remote 37xx Host Configuration Information

This section provides guidelines on the configurations required on the Host PSF Program.

Specifying the JES2 Initialization Statement

Define the Host PSF printer as you would any other SNA-attached printer. For example, on an MVS system you must provide either JES2 or JES3 initialization statements. For an example, see [JES2 Initialization Statement Example](#).

Configuring the Host PSF Printer

For an example of these values, see [JES2 External Writer Procedure Example](#).

The manner in which a host PSF printer is configured depends upon the operating system. You will use one of the following statements:

- PSF/MVS **PRINTDEV** statement
- PSF/VSE **PRINTDEV** statement
- Parameters in the PSF/VM **OPTIONS PDM** file

On each operating system, PSF supports specification of both the application program ID (APPLID) and the logical unit name (LUNAME):

...

APPLID= *appl_prog*

LUNAME= *lu_name*

...

On some operating systems, PSF also supports other configuration parameters. The following text describes these parameters (listed in order of importance) and notes whether they are required or optional:

APPLID (required)

Specifies the application program that is the SNA logical unit provided by VTAM and used by PSF. The **APPLID** value must match:

- An **APPL** statement name in a VTAM application program major node
- The second portion of the **Fully qualified partner LU name** parameter in the SNA Server/6000 LU 6.2 Partner LU profile.

LUNAME (required)

Specifies the SNA logical unit with which PSF tries to initiate a session. The **LUNAME** value must match:

- An **LU** statement name in a **VTAM** switched major node
- The **Local LU name** parameter in an SNA Server/6000 LU 6.2 Local LU profile.

LOGMODE (optional)

Specifies the **VTAM** logon mode table entry that defines characteristics of the session between the logical units identified by the **APPLID** and **LUNAME** parameters. The **LOGMODE** parameter identifies an entry within a logon mode table. The **MODETAB** operand on the **VTAM** switched major node LU statement identifies the logon mode table. If you omit the **LOGMODE** parameter, the **DLOGMOD** operand on the **VTAM switched major node LU** statement identifies the entry within the logon mode table.

Note that if the logical unit identified by the **LUNAME** parameter is a cross-domain resource, you must not use the **LOGMODE** parameter.

SETUP (optional)

Specify **SETUP=FORMS** to cause JES to issue forms setup messages to the operator.

By default, JES issues forms setup messages to the operator for channel-attached printers, but does not issue forms setup messages to the operator for SNA-attached printers.

MGMTMODE={IMMED | OUTAVAIL | DIALIN} (optional)

Determines how the host PSF program and PSF Direct initiate communication.

IMMED

Causes the host PSF program to initiate communication when it is started.

OUTAVAIL

Causes the host PSF program to initiate communication when there is available output to print.

DIALIN

Causes the host PSF program to initiate communication only after a switched line becomes available. The switched line can become available either when VTAM dials out or the remote node dials in.

Note that if you specify DIALIN:

- Do not use the **LOGMODE** parameter
- Include the **LOGAPPL** operand on the **VTAM switched major node LU** statement
- Ensure that the **LOGAPPL** operand on the **VTAM switched major node LU** statement matches the **APPLID** value

FAILURE= { **WCONNECT** | **STOP** } (optional)

Specifies whether or not the host PSF program re-attempts communication after a printer or communication failure. If you do not specify a value for the **FAILURE** parameter, it defaults to **WCONNECT**.

WCONNECT

Specifies that the host PSF program attempts to communicate again.

STOP

Specifies that the host PSF program must be restarted by the operator.

DISCINTV (optional)

Specifies the interval (in seconds) that the host PSF program waits for output to become available to print. If no output becomes available, the host PSF program ends communication with the printer.

Specify 0 to cause the host PSF program to maintain communication indefinitely. If you do not specify a value for **DISCINTV**, it defaults to 0.

Specifying the VTAM Start Option List (ATCSTRxx)

For an example of these values, see [VTAM Start Option List \(ATCSTRxx\) Example](#). You must specify the values illustrated and described below:

CONFIG= <i>nn</i> ,	ATCCON MEMBER OF VTAMLST	x
NETID= <i>network_id</i> ,	NETWORK IDENTIFIER	x
SSCPID= <i>nn</i> ,	SSCP IDENTIFIER	x

:

CONFIG

Specifies the ATCCON *nn* member to use.

NETID

Specifies the network identifier for the host system. The first portion of the **Fully qualified partner LU name** parameter in the SNA Server/6000 LU 6.2 Partner LU profile must match the **NETID** value.

SSCPID

Specifies the System Services Control Point (SSCP) at the host. The SSCPID is a decimal integer from 0 to 65535.

The SSCP, normally VTAM, provides several network management functions. They include managing dependent logical units and accepting Network Management Vector Transports, such as alerts. Alerts often include information about devices that are unavailable or require corrective action.

To configure a PSF Direct host receiver to send alerts to this SSCP, the least significant portion of the **SNA System Services Control Point ID** value in the PSF Direct Host Receiver profile must be the hexadecimal equivalent of the SSCPID value. The **SNA System Services Control Point ID** must be in the form 05xxxxxxxxxxx where x is a hexadecimal digit.

For example, to configure a PSF Direct host receiver to send alerts to an SSCP with an SSCPID value of 283, the host receiver's SNA System Services Control Point ID value must be 05000000011B.

Specifying the VTAM Configuration List (ATCCONnn)

For an example of these values, see [VTAM Configuration List \(ATCCONnn\) Example](#). The VTAM configuration list indicates the application program major nodes that should be made available when VTAM is started. Include the application program major node that contains the application program that PSF uses:

```
appl_pr0g_major_node ,                x
:
```

Specifying the VTAM Application Program Major Node and Application Program

For an example of these values, see [VTAM Application Program Major Node and Application Program Example](#). The pertinent operands for the VTAM Application Program Major Node and Application Program are illustrated and described below:

```
appl_prog_major_node ,  VBUILD TYPE=APPL                x
appl_prog ,             APPL AUTH=ACQ , EAS=1 , SONSCIP=YES  x
:
```

The host PSF program does not support application programs that use APPC=YES or PARSESS=YES. The default value for both **APPC** and **PARSESS** is *NO*.

Specifying the VTAM Mode Table and Entry

For an example of these values, see [VTAM Mode Table and Entry Example](#). The operands for the VTAM Mode Table are illustrated and described below:

```
table_name  MODETAB                x
entry_name  MODEENT LOGMODE=IBM3820T , FMPROF=X'13' , TS PROF=X'07' ,    x
:           PRIPROC=X'B0' , SEC PROT=X'B0' , COMPROT=X'B0B1'            x
           PSERVIC=X'060200000000000000000000200'                    x
           PSNDPAC=X'10' , SRCVPAC=X'10' , SSNDPAC=X'00'              x
           RUSIZES=X'8787'
```

PSNDPAC

Specifies the primary send pacing count. This value influences performance and can be adjusted as desired. Specifying X ' 10 ' yields good throughput in most configurations.

SRCVPAC

Specifies the secondary receive pacing count. This value influences performance and can be adjusted as desired. Specifying X ' 10 ' yields good throughput in most configurations.

RUSIZES

Specifies the maximum Request Unit (RU) sizes from the primary and secondary logical units. The RU sizes influence performance and can be adjusted as desired. Specifying X ' 8787 ' means 1024 bytes for both RU sizes and yields good throughput in most configurations.

Other configuration parameters are influenced by the RUSIZES specification. These include:

- the **Maximum RU size** parameter in the SNA Server/6000 Mode profile.
- the **MAXSTL** operand in the NCP **LINE** statement.

Specifying the VTAM Switched Major Node

For an example of these values, see [VTAM Switched Major Node Example](#).

A different set of statements and values is required depending upon whether

- a **calling** Communications Server for NT link station [initiates](#) a link connection with a 37xx communication controller
- a **listening** Communications Server for NT link station [waits](#) for the 37xx communication controller to initiate a link connection.

Illustration of a **calling** Communicaitons Server for NT link station:

```

node_name  VBUILD  TYPE=SWNET
*
pu_name    PU      ADDR=nn,                ADDRESS REQUIRED, BUT IGNORED    x
           CPNAME=cp_name,        CONTROL POINT NAME              x
:          MAXOUT=7,              LINK LEVEL WINDOW                x
           MODETAB=mode_table,    LOGON MODE TABLE                x
           DLOGMOD=mode_entry,    LOGON MODE TABLE ENTRY          x
           VPACING=0,              NO PACING TO BOUNDARY NODE
*
lu_name    LU      LOCADDR=nn,                INDEPENDENT LU

```

Illustration of a **listening** Communicaitons Server for NT link station:

```

node_name  VBUILD  TYPE=SWNET,MAXGRP=1,MAXNO=1
*
pu_name    PU      ADDR=nn,                ADDRESS REQUIRED, BUT           x
           CPNAME=cp_name,        CONTROL POINT NAME              x
:          MAXOUT=7,              LINK LEVEL WINDOW                x
           MODETAB=mode_table,    LOGON MODE TABLE                x
           DLOGMOD=mode_entry,    LOGON MODE TABLE ENTRY          x
           VPACING=0,              NO PACING TO BOUNDARY          x
           NODE
*
path_name  PATH  DIALNO=xx044000nnnnnnnnn,
           GRPNM=ncp_group,
*
lu_name    LU      LOCADDR=nn,                INDEPENDENT LU

```

The following describes the pertinent operands on the **VBUILD** statement:

TYPE

Specify **SWNET** to indicate that the node is a switched major node.

MAXGRP

Specifies the number of unique path groups (**GROUP** names) that are defined in the **GRPNM** operand of all **PATH** statements within the switched major node. There is one unique path group in the switched major node guideline presented in the figure for a Communications Server [listening](#) link station.

MAXNO

Specifies the number of unique Token-Ring addresses that are defined in the **DIALNO** operand of all **PATH** statements within the switched major node. There is one unique Token-Ring address in the switched major node guideline presented in the figure for a Communications Server [listening](#) link station.

The following describes the pertinent operands on the **PU** statement:

Note that the **DLOGMOD**, **MODETAB**, and **VPACING** operands are **LU** operands, but are included here on the **PU** statement. **VTAM** definitions support a "sift-down effect" that allows you to code an operand on a higher-level statement so you do not need to code it on each lower-level statement for which the same value is desired.

There is only one logical unit in the guideline presented here, so the sift-down effect is for demonstration only. If the **DLOGMOD**, **MODETAB**, and **VPACING** operands are specified on the **PU** statement, they do not have to be specified on any of the **LU** statements.

ADDR

Specifies the address of the physical unit. Note that this operand is required, but ignored.

CPNAME

Identifies the control point. The value specified for **CPNAME** must match the **Control Point (CP)** name value in the Communications Server Control Point profile. By convention, the **CPNAME** value usually matches the **PU** name. Either the **CPNAME** operand or both the **IDBLK** and the **IDNUM** operands are required. **CPNAME** can only be used with **PU** type 2.1 nodes, such as Communications Server for NT.

MAXDATA

Specifies the maximum amount of data (in bytes) that the physical unit can receive in one path information unit (PIU). This amount includes the transmission header (TH) and the request/response header (RH).

Note that **MAXDATA** is ignored for type 2.1 nodes, such as Communications Server for NT, that are attached through an NCP with peripheral node type 2.1 support. The type 2.1 node indicates the maximum PIU size when the connection is established. The value that SNA Server/6000 supplies can be configured using the Token-Ring SNA DLC profile's **User-defined maximum I-Field size?** and **Max. I-Field** size parameters.

MAXOUT

Specifies the maximum number of path information units (PIUs) that are sent to the physical unit before waiting for a response from that physical unit. For optimum performance, the **MAXOUT** value must be equal to, or greater than, the **Receive window count** in the Communications Server for NT Token-Ring SNA DLC profile. The **Receive window count** parameter specifies how many frames are received by the link station before Communications Server for NT sends an acknowledgement.

MAXPATH

Specifies the number of dial-out paths to the physical unit. There is one dial-out path presented in the figure for a Communications Server [listening](#) link station.

MODETAB

Specifies the name of the logon mode table that contains entries that describe session characteristics.

DLOGMOD

Specifies the name of the logon mode table entry that describes session characteristics.

VPACING

Determines how VTAM paces the flow of the data from VTAM to the boundary node to which the logical unit is connected. In this configuration, the boundary node is the communication controller. A value of zero means that no pacing is performed for sessions with the logical unit, or that the largest possible pacing is used if the session is adaptively paced.

The following describes the pertinent operands on the **PATH** statement:

DIALNO= *xx044000nnnnnnnn*

This parameter value has three parts:

xx

Specifies the Token-Ring Interface Coupler (TIC) number in the communication controller.

04

Specifies the Service Access Point (SAP). This value must always be 04.

4000nnnnnnnn

Specifies the Token-Ring address of the Token-Ring adapter in the NT workstation. Although Token-Ring addresses include twelve hexadecimal digits, the **VTAM DIALNO** operand only accepts digits in the range 0-9. Therefore, an alternate token-ring address that contains only digits in the range 0-9 must be assigned to the Token-Ring adapter in the NT workstation.

GRPNM

Refers to a logical **GROUP** statement in the NCP definitions.

The following describes the pertinent operands on the **LU** statement:

LOCADDR

LOCADDR=0 specifies that this logical unit is an independent logical unit. An SSCP-LU session does not have to be established prior to an LU-LU session with an independent logical unit. For independent logical units, the **Local LU is dependent?** parameter in the Communications Server for NT LU 6.2 Local LU profile must be **no**. To use a dependent logical unit, specify a value between 1 and 255 for **LOCADDR**. Also, in the Communications Server for NT LU 6.2 Local LU profile, specify **yes** for the **Local LU is dependent?** parameter, and the **LOCADDR** value for the **Local LU address** parameter.

SSCPFM

The **SSCPFM** operand indicates the type of request units (RUs) that the logical unit supports over its SSCP-LU session. The guidelines illustrated in both the [calling](#) link station and the [listening](#) link station use an independent logical unit. Therefore, the **SSCPFM** operand is not specified. If you require a dependent logical unit, specify **SSCPFM=USSSCS**.

Specifying the Network Control Program (NCP) Definitions

The keywords and values for the Network Control Program (NCP) definitions are illustrated and described below. For an example of these values, see [Network Control Program \(NCP\) Definitions Example](#).

The Network Control Program (NCP) definitions include a physical group and a logical group. The **PORTADD** keyword on the **LINE** statement and the **PHYPORT** keyword on the logical **GROUP** statement both refer to the same port number.

```

:
  pgroup_name  GROUP  ECLTYPE=PHYSICAL,          PHYSICAL GROUP          x
                ISTATUS=ACTIVE,                INITIAL STATUS          x
  line_name    LINE   ADDRESS=(line_number,FULL), LINE NUM AND DATA TRANS MODE x
                LOCADD=4000nnnnnnnnnn,        TOKEN RING ADDRESS FOR LINE x
:
                MAXTSL=nnnnn,                MAXIMUM BYTES OF DATA  x
                PORTADD=port_number,          PORT ADDRESS            x
                RVCBUFC=4095,                BUFFER CAPACITY        x
  pu_name      PU
  lu_name      LU   ISTATUS=INACTIVE,          INITIAL STATUS
*
  lgroup_name GROUP  ECLTYPE=LOGICAL,          LOGICAL GROUP          x
                ISTATUS=ACTIVE,                INITIAL STATUS          x
                AUTOGEN=n,                    # OF LINE AND PU PAIRS GENED x
                CALL=INOUT,                    CALL IN OR OUT          x
                PHYPORT=port_number          CORRELATES WITH PORTADD
*

```

The following describes the pertinent keywords on the **LINE** statement:

ADDRESS

Specifies the relative line number and data transfer mode for the line.

LOCADD

Indicates the Token-Ring address that the Token-Ring Interface Coupler (TIC) uses.

MAXTSL

Specifies the maximum amount of data (in bytes) that can be transmitted over the Token-Ring connection. Note that this amount includes both the transmission header (TH) and the request/response header (RH). **MAXTSL** must be greater than or equal to the maximum size of a path information unit (PIU).

PORTADD

Assigns a port number to the physical line.

RCVBUFC

Specifies the NTRI (NCP token-ring interconnect) buffer capacity for receiving data from a telecommunication link during one data transfer. The value must be greater than or equal to the maximum size of a path information unit (PIU).

The following describes the pertinent keywords on the logical **GROUP** statement:

AUTOGEN

Specifies how many **LINE** and **PU** statements the NCP Definition Facility (NDF) should automatically add to this group.

CALL

Specifies whether the link station in the communication controller should call out to the remote link station, or whether the remote link station should call into the communication controller link station. Specify **CALL=INOUT**, which enables either calling or listening link stations to be configured in Communications Server for NT. **CALL** is a **LINE** statement operand that sifts down to each of the automatically-generated **LINE** statements.

PHYPORT

Associates the logical lines in this group with a particular physical line. The **PHYPORT** value must match the **PORTADD** value on the **LINE** statement for the physical line.

Specifying Communications Server for NT Configuration Profiles

This section contains guidelines for configuring the Communications Server for NT Profiles. To access these profiles, see [Accessing the Communications Server for NT Profiles](#).

Node setup

The following describes how to specify the PSF Direct values that are displayed in the [37xx Note Setup](#) example.

Basic Configuration

To view an example screen with these values, see [37xx Node Basic](#).

Fully-qualified Control Point (CP) name

Specifies the name of the component that manages the resources of that node.

If the **CPNAME** operand is used in the VTAM switched major node **PU** statement (rather than **IDBLK** and **IDNUM**), then the **Control Point (CP) name** must match the **CPNAME** operand. By convention, the **CPNAME** is usually the same as the **PU** name. Either the **CPNAME** operand or both the **IDBLK** and the **IDNUM** operands are required. **CPNAME** can only be used with PU type 2.1 nodes, such as Communications Server for NT.

CP alias

Specifies an alternative name for the **CP**. Local applications can use this name, instead of the fully-qualified **CP** name, to refer to the local **CP**.

Local Node ID -

Specifies both the **Block ID** -- a 3-digit hexadecimal string that identifies the product type in an SNA network -- and the **Physical Unit ID** -- a 5-digit hexadecimal string that identifies a physical unit (**PU**).

If the **IDBLK** and **IDNUM** operands are used in the VTAM switched major node **PU** statement (rather than **CPNAME**), then the **Local Node ID** value in the Node setup profile must match the combined **IDBLK** and **IDNUM** operands. The **IDBLK** operand is normally 071 for Communications Server for NT. Either the **CPNAME** operand or both the **IDBLK** and **IDNUM** operands are required. **CPNAME** can only be used with PU type 2.1 nodes, such as Communications Server for NT.

If you are migrating from an AIX operating system, **Local Node ID** matches the **XID Node ID** parameter.

Node Type

Specifies the type of node. Take the `End node` default.

If you are migrating from an AIX operating system, **Node Type** matches the **Control Point Type** parameter.

Advanced Configuration

To view an example screen with these values, see [37xx Node Advanced](#).

This panel should be allowed to default as specified in the [37xx Node Setup](#) example.

Registration of LU resources

Specifies that directory information about the local logical units (LUs) 6.2 is sent to the server. As the example shows, check both the **Network node server** and the **Central Directory Server**.

Discovery Support

Specifies a LAN address resolution protocol that can be used to find another node that matches given search criteria. By adjusting the search parameter, a node may search for APPN network nodes, nodes that provide SNA boundary function, or AS/400s. Select the check box to enable Discovery Support.

Device Configuration

The following describes how to specify the PSF Direct values that are displayed in the [37xx Device Configuration](#) example.

From the pop-up **Device Type** window, select **LAN** for your Data Link Control (DLC) type. A DLC is a set of rules that nodes on a data link (such as an SDLC link or a Token-Ring) use to accomplish an orderly exchange of information. The **Adapter number** is the only parameter that you should have to either set or change.

Basic Configuration

To view an example screen with these values, see [37xx Device Basic](#).

Port name

Specifies the port name of the physical connection to the link hardware. This value consists of the word LAN, the adapter number, and the local SAP number, with an underscore between the adapter number and the local SAP number.

Adapter number

Specifies a value from 0 to 7 that uniquely identifies this adapter. Specify this value after you specify LAN as the DLC type.

Local SAP

Specifies the local service access point (SAP) number of the local port as a value from 04 through FC. Note that this number must be a multiple of four. Take the default of 04.

Advanced Configuration

To view an example screen with these values, see [37xx Device Advanced](#).

For this panel, you should take the defaults that are specified in the [37xx Device configuration](#) example and described below.

XID retry interval

Specifies the time the link station waits for a reply to a previous XID command before resending that command. Specify 60. If the link station is a calling link station, this value causes it to try to establish a link connection with the 37xx communication controller every 60 seconds, until a link connection can be established. If you are migrating from an AIX operating system to a Windows NT operating system, this parameter replaces the **Response Timeout** parameter from the **Token-Ring SNA DLC** profile.

XID retry limit

Specifies the maximum number of times an XID command will be retransmitted before Communications Server for NT presumes that the link is broken and stops retrying. Specify 0. If the link station is a calling link station, this value indicates that there is no limit on the number of attempts the link station makes to establish a link connection with the 37xx communication controller. The interval between the attempts is defined by the previous parameter. If you are migrating from an AIX operating system to a Windows NT operating system, this parameter replaces the **XID Retransmit count** parameter from the **Token-Ring SNA DLC** profile.

Test retry interval

Specifies the time between attempts to find the adjacent link station on the LAN. This parameter is needed to establish communication with the network and does not necessarily relate to VTAM or the PSF Host system. The number of times an XID is sent is based on the configured **XID retry limit**.

Test retry limit

Specifies the number of times COmmunications Server attempts to find the adjacent link station on the LAN. Specify a value from 3 to 30.

Receive window count

Specifies a value that should be equal to the **MAXOUT** value in the VTAM switched major node **PU** statement. The Receive window count defines the size of the link-level window. It specifies the maximum number of frames to receive before sending a link-level acknowledgement. The VTAM **PU MAXOUT** value indicates the number of frames the 37xx communication controller sends before waiting for a link-level acknowledgement. If the **MAXOUT** operand is less than the **Receive window count** parameter, extremely poor throughput can result. The default **MAXOUT** value is 1. The default **Receive window count** value is 8. These defaults must be adjusted to yield acceptable throughput.

Maximum PIU size

Specifies a value between 99 and 65535 bytes that represents the maximum number of bytes that are contained in the data buffer used by SNA sessions for this link. If the value of the **Maximum PIU size** exceeds the frame size supported by your local device driver, the value will be reduced to match the frame size.

Performance Configuration

To view an example screen with these values, see [37xx Device Performance](#).

Port name

For this panel, you should take the defaults that are specified in the [37xx Device configuration](#) example.

If you are migrating from an AIX operating system to a Windows NT operating system, see below for how values are mapped:

Windows NT Parameter	AIX Value
Idle timeout	Inactivity time-out
Busy state Timeout	n/a
Acknowledgement delay	n/a
Acknowledgement timeout	Acknowledgement timeout
POLL response timeout	n/a
Anticipated outstanding transmits	Transmit window count
Receive buffer count	n/a

Reactivation Configuration

To view an example screen with these values, see [37xx Device Reactivation](#).

Port name

For this panel, you should take the defaults that are specified in the [37xx Device configuration](#) example.

Peer Connection Configuration

The following describes how to specify the PSF Direct values that are displayed in the [37xx Peer-to-Peer Connection Configuration](#) example. This configuration is a call setup because NT searches for and calls the host PSF program.

Basic Configuration

To view an example screen with these values, see [37xx Peer Basic](#).

Link station name

Specifies a 1- to 8-byte character string that is used to identify a connection

Device name

Specifies the name of the port associated with this link station. This value must match the **Port name** value specified under the Basic options for [Device configuration](#).

Destination address

Specifies a 12-character hexadecimal string that specifies the address to activate a connection to the destination. This value must be specified so the NT system can search for and call the PSF Host program.

Swap address bytes

Check this field to bit-swap the address currently in the **Destination address** field. You may need to select this check box if the next link in the network is an Ethernet link. If not, you can use the default (unchecked).

Advanced Configuration

To view an example screen with these values, see [37xx Peer Advanced](#).

Activate link at start

Specifies that you will use the link reactivation values specified in the port (device) link reactivation definition. Ensure that you select this check box.

APPN support

Specifies whether CP-CP sessions are supported on this connection. Select the check box to specify APPN support.

PU name

Specifies the physical unit (PU) name is the name of the component that manages and monitors the resources (such as attached links and adjacent link station) associated with a node. The default PU name is automatically created. This definition can be changed.

Block ID

Identifies the product type in an SNA network.

Physical Unit ID

Identifies the physical unit (PU) or component that manages and monitors the resources (such as attached links and adjacent link stations) associated with a node.

Note that the remaining two panels in the Peer-to-Peer Connection Configuration (**Adjacent Node** and **Reactivation**) should take their default values.

Partner LU 6.2 Configuration

The following describes how to specify the PSF Direct values that are displayed in the [37xx Partner LU 6.2 Configuration](#) example, which is used to point the personal computer to the host PSF program.

Basic Configuration

To view an example screen with these values, see [37xx Partner Basic](#).

Partner LU name

Specifies the network identifier of the network in which the host PSF program resides (followed by a period), and the logical unit name used by the host PSF program. The network identifier portion must match the **NETID** value in the **VTAM start option list (ATCSTRxx)**. The logical unit name portion must match the **APPLID** parameter on the PSF/MVS **PRINTDEV** statement, the PSF/VSE **PRINTDEV** statement, or the PSF/VM **OPTIONS PDM** file. That **APPLID** parameter on the PSF host system must also match an **APPL** statement in a VTAM application program major node. (Do not check the **Wildcard** check box.)

Partner LU alias

Specifies the alternate name for the partner LU. Local applications can use this name, instead of the fully-qualified LU name, to refer to the partner LU. While you can choose any meaningful value, IBM recommends specifying the second qualifier of the **Partner LU name**.

Fully qualified CP name

Select: **New** to enter the fully-qualified CP name of the partner LU's owning control point. Communications Server for NT requires this field. Infoprint Manager uses this field as the target for any alerts sent by the PSF Direct program.

Advanced Configuration

To view an example screen with these values, see [37xx Partner Advanced](#).

Maximum LL record size

Specifies a value between 0 and 32767 as the maximum size of the logical record in the data stream for basic conversations. Specify the default (32767) because the PSF Host program and the PSF Direct Host Receiver should both be able to handle the full range.

Conversation security support

Specifies that the partner logical unit (LU) is authorized to validate the user identifiers for the local LUs. Select the check box to specify conversation security support if you have matching support on the Host PSF program. If not, leave this box unchecked.

Parallel session support

Specifies whether the partner LU supports two or more currently active sessions between the same two LUs using different pairs of network addresses or session identifiers. Because neither PSF Direct nor the PSF Host programs support two sessions with the same Partner LU, do not select this check box.

Local LU 6.2 Configuration

The following describes how to specify the PSF Direct values that are displayed in the [37xx Local LU Configuration](#) example.

Basic Configuration

To view an example screen with these values, see [37xx Local LU 6.2 Basic](#).

Local LU name

Specifies a 1- to 8-byte character string that identifies your workstation and gives transaction programs access to the network. This name must match the Partner LU that has been defined at the Host PSF program, as indicated in the [37xx Worksheet Example](#).

Local LU alias

Specifies the name for the local LU that is used by Infoprint Manager when configuring the PSF Direct Host Receiver.

Dependent LU

Specifies whether (if checked) this LU requires assistance from a system services control point (SSCP) in order to initiate an LU-LU session. If you select this check box, ensure that the LU is specified as Dependent on the host PSF program.

SNA API client use

Since this LU is meant to be used by a server-based transaction program (TP), this field should not be checked.

Advanced Configuration

To view an example screen with these values, see [37xx Local LU 6.2 Advanced](#).

LU session limit

Specifies the maximum number of sessions supported by the LU as a value between 0 and 65535. Specify 1.

Synchronization support

Select this check box if another application is supplying synchronization point management (DB/2, for example). In this instance, do not select it.

Mode Configuration

The following describes how to specify the PSF Direct values that are displayed in the [37xx Mode Configuration](#) example.

Basic Configuration

To view an example screen with these values, see [37xx Mode Basic](#).

Mode name

Specifies the characteristics for the session that will be allocated for the conversation. This value is used by the initiator. The **Mode name** in the BLANK profile is 8 spaces.

PLU mode session limit

Specifies a value between 0 and 32767 as the primary logical unit (PLU) mode session limit, or maximum number of concurrently active LU-LU sessions that a particular LU can support. Take the default.

Minimum contention winner sessions

Specifies a value between 0 and 32767 as the minimum number of sessions that can be activated by a local logical unit (LU) using this mode to win a contention with a partner. Take the default.

Advanced Configuration

To view an example screen with these values, see [37xx Mode Advanced](#).

Maximum negotiable session limit

Specifies a value between 0 and 32767 as the maximum number of sessions allowed in this mode between any local logical unit (LU) and partner LU. Take the default

Receive pacing window size

Specifies the lesser of this parameter's value and the **SRCVPAC** value in the VTAM **MODEENT** statement. Specifying 16 yields good throughput in most configurations. This parameter influences performance and can be adjusted as desired.

Auto activate sessions

Specifies a value between 0 and 32767 as the number of parallel LU 6.2 sessions to automatically start when an initial session is started using this mode. Specify 0 so no parallel sessions can be started automatically for this application.

Class of Service name

Specifies the name of a set of transport network characteristics. Select the default: #CONNECT.

Use default RU size

Instructs the node to use the default maximum size for the request/response unit (RU) sent and received on the sessions. Do not select the check box.

Maximum RU size

Set this value to 1024, if it does not automatically specify that value when you remove the check from the **Use default RU size** parameter above.

Transaction Program Configuration

The following describes how to specify the PSF Direct values that are displayed in the [37xx Peer-to-Peer Connection Configuration](#) example. Note that check box values that should not be selected and most default values are not described.

Basic Configuration

To view an example screen with these values, see [37xx Transaction Basic](#).

TP name

Specifies a 1- to 64-byte character string for the program that uses the advanced program-to-program communications (APPC) system to communicate with a partner application program at the partner node. Select `$DPF`. For users migrating from an AIX operating system to a Windows NT operating system, note that this value changes from a binary `30F0F0F0` to a non-binary `$DPF`. Ensure that the **Service TP** check box is unchecked because it indicates a non-binary value.

Complete pathname

Specifies an 1- to 255-byte character string that describes the location of the program to be executed. The location can include the drive, the directory, the subdirectory, and the file name. For the [37xx Transaction program configuration](#) example, `i:\ipmntinst` specifies the location where Infoprint Manager for NT is installed on your system.

Conversation type

Specifies the conversation type allowed to start the transaction programs (TPs) using an LU 6.2 session. Select **Basic** for Basic conversation for system TPs.

Synchronization level

Specifies the level allowed on allocation requests that start the local and remote transaction programs (TPs). Select **Any**.

Conversation security required

Allows controlled access to system resources through security parameters associated with a request for access to those resources. If this check box is selected, conversation security information is required to start the TP. Incoming allocation requests for this TP without the conversation security information will be rejected. Do not check this box.

Advanced Configuration

To view an example screen with these values, see [37xx Transaction Advanced](#).

Ensure that **Dynamically loaded** and **Background process** (the two items checked in the [37xx Transaction program configuration](#) example) are the only items checked. If you specify other options, this transaction program will not work.

Receive_Allocate timeout

Specifies a value between 0 and 65535 seconds that identifies the time that a Receive_Allocate verb will be queued while waiting for an Attach. Specify 60.

Incoming allocate timeout

Specifies a value between 0 and 65535 seconds that identifies the time that an incoming Attach will be queued waiting for a Receive_Allocate. Specify 60.

TP instance limit

Specifies a value between 0 and 65535 seconds that identifies the maximum number of concurrently active TP instances. Specify at least 1 (or the number of LU's that you have defined).0 means no limit.

Dynamically loaded

Specifies whether the transaction program (TP) can be dynamically started by an allocation request received on a conversation. Select the check box to dynamically load the TP.

Background process

Specifies that the program will execute in the background. Only 32-bit programs can multitask in the Windows NT environment. Select the check box to use the background process.

Local or Remote 37xx Configuration Worksheets

Use the following worksheets to configure PSF Direct on both the host PSF and Infoprint Manager for NT:

- Use the [37xx Worksheet Example](#) to see how Communications Server for NT configuration settings used in the [Local or Remote 37xx Token-Ring Example](#) related to other configuration settings
- Use the [37xx Worksheet Sample](#) to record Communications Server for NT values used at your installation that related to other configuration settings.

37xx Worksheet Example

Communication Server	Value	Infoprint Manager	VTAM	NCP
Control Point: Control Point (CP) name	NT01		PU: DEVTESTB PU: DEVTESTB	
Token-Ring SNA DLC: Receive window count	7		PU: 7	
Token-Ring Link Station: Remote link address	4000023101088			LINE: 400023101088
LU 6.2 Local LU: Local LU name	PSFD0101	LUNAME	LU: PSFDC4LU	
LU 6.2 Local LU: Local LU is dependent?	no		LU: 0	
LU 6.2 Local LU: Local LU address	n/a		LU: 0	
LU 6.2 Partner LU:	USIBMBQ.FSAE	APPLID	ATCSTRxx:	

Fully qualified partner LU name	S618		NETID APPL: FSAES618	
LU 6.2 Side Information: Fully qualified partner LU name	n/a	APPLID	ATCSTRxx: NETID APPL: n/a	
LU 6.2 Mode: Receive pacing window	16		MODEENT: 10	
LU 6.2 Mode Maximum RU size	1024		MODEENT: 8787	

37xx Worksheet Sample

Communication Server	Value	Infoprint Manager	VTAM	NCP
Control Point: Control Point (CP) name			PU: name PU: CPNAME	
Token-Ring SNA DLC: Receive window count			PU: MAXOUT	
Token-Ring Link Station: Remote link address				LINE: LOCADD
LU 6.2 Local LU: Local LU name		LUNAME	LU: name	

LU 6.2 Local LU: Local LU is dependent?			LU: LOCADDR	
LU 6.2 Local LU: Local LU address			LU: LOCADDR	
LU 6.2 Partner LU: Fully qualified partner LU name		APPLID	ATCSTRxx: NETID APPL: name	
LU 6.2 Side Information: Fully qualified partner LU name		APPLID	ATCSTRxx: NETID APPL: name	
LU 6.2 Mode: Receive pacing window			MODEENT: SRCVPAC	
LU 6.2 Mode Maximum RU size			MODEENT: RUSIZES	

Starting an IBM SecureWay Communications Server for NT Configuration

Use the following procedure to start all IBM SecureWay Communications Server for NT configurations that you created from the Network Configuration Examples and Guidelines.

1. From your NT desktop view, double-click on the **SNA Node Operations** icon that resides on your desktop:



2. From the **Communications Server Node Operations** window, click on the plus (+) sign next to **Connections**.
3. If your configuration is an independent LU, highlight **Peer Connections**. If it is a dependent LU, highlight **Host Connections**.
4. From the window's main menu, select **Operations-->Start Node**.
5. From the **Open** pop-up window, select the *.acg file that represents the configuration you wish to start and click **Open**.

From the right pane of the **Communications Server Node Operations** window, a lightning bolt icon with a Linkxxx description (where xxx represents the number of links on your system) appears. When the lightning bolt icon turns completely **yellow**, the link is active and PSF Direct is ready to receive jobs from the host PSF system. If the lightning bolt turns completely **red**, the link has failed and you need to review your configuration on both the Infoprint Manager Windows NT server and the PSF host program.

Configuring PSF Direct

PSF Direct acts as a communication protocol converter that exchanges data with a host PSF program using an SNA LU 6.2 session, and relays the data to an Infoprint actual destination.

From an application perspective, the entire SNA network can be viewed as a black box with two access points called **logical units**. An LU 6.2 session runs through the network and connects the two logical units, as displayed in the end-to-end view of logical components of a PSF Direct configuration displayed below.

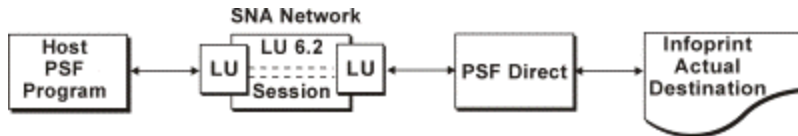

When you configure a PSF Direct Receiver, you associate a logical unit with an Infoprint actual destination (as shown below):



Creating and Configuring an Infoprint PSF Direct Destination (printer)

Before creating an actual destination (printer) to send jobs from PSF Direct, you should determine the type of configuration. See the Administrative procedure "Selecting a type of actual destination," which can be found at the Infoprint Manager for Windows NT sitelet at <http://www.ibm.com/printers>. When you create an Infoprint actual destination, Infoprint adds the facilities required for Infoprint to communicate with the printer. These include a subdirectory and files in the `\var\psf` directory.

For PSF Direct, you can create and configure the Infoprint PSF Direct destination in two ways:

- [Using the Infoprint Manager Administration GUI](#)
- [Using the Infoprint Manager Management Console](#)

Using the Infoprint Manager Administration GUI

If you will be using the PSF Direct destination to print data from a PC-based source as well as from a host system, you must use the **Infoprint Manager Administration GUI** to create an actual destination. Use the **Printer-->Create-->PSF** menu to access the **Create Printer Wizard** and refer to the online help in the **Infoprint Manager Administration GUI**.

To configure the PSF Direct destination created above, you can use the **Infoprint Manager Administration GUI**. Select the actual destination (printer) you want to configure, then use the **Printer-->Properties** menu to open the **Printer Properties Notebook** and refer to the online help in the **Infoprint Manager Administration GUI**.

Using the Infoprint Manager Management Console

If you will be using the PSF Direct destination to print data from PSF host systems only, you can use the Infoprint Manager Management Console to create an actual destination. Ensure that the Infoprint Windows NT server is running and use the **Edit-->New-->Destination** path and select from the range of potential PSF Direct destinations provided. For more information on configuring this destination, see the related **Infoprint Manager Management Console** help.

To communicate with an Infoprint actual destination, PSF Direct uses the facilities that Infoprint created when you added the printer. However, PSF Direct does not accept data from the Infoprint queue that was created for the printer. Rather than obtaining print data from the Infoprint queue, PSF Direct uses an SNA LU 6.2 session that you created through IBM SecureWay Communications Server for NT to obtain print data from a host PSF program.

When you add a PSF Direct receiver, you must indicate which Infoprint actual destination the host receiver should use. This procedure is described in [Defining the PSF Direct Host Receiver](#).

Defining the PSF Direct Host Receiver

IBM recommends setting up the PSF Direct Receiver and managing your PSF Direct operations from the **MVS Download Receiver Manager** window so you can use the **Management Console for Infoprint Manager Server...** window to track Server events.

To set up a PSF Direct Receiver, use the following procedure:

1. From the **Management Console for Infoprint Manager Server...** window, use the **Edit-->PSF Direct Receiver Management...** menu to access the **PSF Direct Receiver Manager** window.
2. Click on the **Add** button.
3. From the **Add PSF Direct Receiver** pop-up menu, specify a value in the **SNA LUNAME** field that matches the SNA Logical Unit name defined through the Secure Way Communication Server configuration.
4. Click on the drop-down menu next to the **Target Destination** field and highlight the Infoprint logical or actual destination to which you want to default for this PSF Direct Receiver.

This list consists of all the logical and actual destinations that have been defined in the **Infoprint Manager Administration GUI**.

5. Allow both numeric values in the the **SNA System Services Control Point ID** field and the **NMVT Subsystem name** field to default.
6. Specify a numeric value from 0 to 9999 (in seconds) for the **Inactivity limit** field.

Setting this value to the system default of 9999 causes the PSF Direct receivers to wait indefinitely if the printer is not available. For more information about the **Inactivity limit** field, see [Automatically Stopping a PSF Direct Host Receiver](#).

7. Specify a numeric value from 0 to 9999 (in seconds) for the **Printer busy limit** field.

Setting this value to the system default of 9999 causes the PSF Direct receivers to wait indefinitely if the printer is not available. For more information on setting this field, see both [Controlling the Wait Period for a PSF Direct Host Receiver](#).

8. Once you are satisfied with the fields on the **Add PSF Direct Receiver** pop-up menu, click on the **Ok** button.
9. Infoprint adds a PSF Direct Receiver to the main pane, with a red marker and STOPPED displaying in the **Status** column.
10. Within a minute or two, the PSF Direct Receiver that you just created will change marking from red to green and RUNNING will display in the **Status** column. At this point, you can submit jobs from the MVS host system for printing directly on Infoprint Manager printers.

For examples of PSF Direct Receivers created for different host programs, see [PSF Direct Host Receiver: Examples](#).

Starting a PSF Direct Host Receiver

IBM SecureWay Communications Server for NT starts a PSF Direct receiver automatically when a host PSF program causes an SNA LU 6.2 session to be established and allocates an SNA conversation on that session. As a result, a host system operator indirectly causes a PSF Direct host receiver to be run by starting a host PSF program that causes IBM SecureWay Communications Server for NT to begin the PSF Direct host receiver.

The operator on the Infoprint Manager Windows NT server does not need to do anything to start a PSF Direct host receiver, as long as IBM SecureWay Communications Server for NT is active on the Windows NT server.

Stopping a PSF Direct Host Receiver

A PSF Direct host receiver can be stopped in several ways:

- The host system operator can end the host PSF program that communicates with the PSF Direct host receiver. When the host PSF program ends the SNA conversation with the PSF Direct host receiver, the PSF Direct host receiver automatically ends.
- The host PSF program's **Disconnect Interval** parameter can be exceeded.

If the host PSF program is waiting for new print files and none become available within the period specified by the **Disconnect Interval** parameter, the host PSF program ends the SNA session with the PSF Direct host receiver. The PSF Direct host receiver then ends.

- The PSF Direct host receiver **Inactivity Limit** can be exceeded.

If the PSF Direct host receiver is waiting for data from the host PSF program and no data arrives within the period specified by the **Inactivity Limit** value, the PSF Direct host receiver UNBINDs the SNA session with the host system.

The **Inactivity Limit** defaults to infinite (9999 seconds) and should only be used in some configurations where a printer is shared.

- If an operator at the Windows NT system stops IBM SecureWay Communications Server for NT, all SNA sessions end, causing all PSF Direct host receivers to end. An operator can also use IBM SecureWay Communications Server for NT to stop an individual SNA session. If the session was used by a PSF Direct host receiver, that PSF Direct host receiver ends.

For information about stopping a PSF Direct host receiver working with a shared Infoprint actual destination, refer to both [Manually Stopping a PSF Direct Host Receiver](#) and [Automatically Stopping a PSF Direct Host Receiver](#).

Displaying the Status of a PSF Direct Destination on the Windows NT/2000 System

Infoprint provides two methods for users to display the status of a PSF Direct host receiver:

- [the Infoprint Manager Management Console](#)
- [the psfstat command](#)

The **Infoprint Manager Management Console** allows you to view the status of Infoprint actual destinations and PSF Direct Receivers. If you click on **PSF Direct Host Receivers** in the left pane, the **PSF Direct Host Receivers** view shows up in the right pane. If you are not using the **Management Console for Infoprint Manager Server...** window to track server events, this is the easiest method to display PSF Direct status. However, if you are using the **Management Console for Infoprint Manager Server...** window to track server events, you should use the **psfstat** command to display status.

Note that if you click **destinations** in the left pane of the **Management Console for Infoprint Manager Server...** window, Infoprint displays the status of all your actual destinations.

The **psfstat** command displays information about the status of Infoprint actual destinations and PSF Direct receivers. It tells you whether each Infoprint printer is receiving data from either the Infoprint Manager Windows NT server or from a PSF Direct receiver. The **psfstat** command provides the source of the display provided by the **Infoprint Manager Management Console**.

Specifying `psfstat` from a Command Prompt window could display the following:

Printer	Attachment	Data	Printer status	Active	Waiting
3827	channel	IPDS	--	--	--
4000wa	TCP/IP	IPDS	intervention	[Queue]	--
4000wb	TCP/IP	IPDS	ok	PSFVM1	[Queue], PSFMVS
ps14	direct	PS	ok	[Queue]	--

LU name	Printer	Attachment	Data	Printer status	Receiver Status
PSFMVS	4000wb	TCP/IP	IPDS	ok	sess/prtr_busy
PSFVM1	4000wb	TCP/IP	IPDS	ok	sess/prtr_con
PSFVSE1	4000wb	TCP/IP	IPDS	ok	idle

This display indicates that

1. Printer 3827 is not active.
2. Printer 4000wa is printing data from Infoprint Manager ([Queue]) and operator intervention is required at the printer.
3. Printer 4000wb is printing data from a PSF Direct receiver that uses the SNA logical unit name (**LUNAME**) PSFVM1. Additional data is also available on the Infoprint actual destination and from a PSF Direct receiver that uses the SNA **LUNAME** PSFMVS. The order of the waiting data sources does not indicate which source will access the printer next.
4. Printer ps14 is printing data from Infoprint Manager.
5. Receiver PSFMVS is in session with the host system and is waiting for printer 4000wb.
6. Receiver PSFVM1 is in session with the host system and is connected to printer 4000wb.
7. Receiver PSFVSE1 is in session with the host system and is idle, but connected to printer 4000wb.

Note that the **psfstat** command can be used to display information about any Infoprint actual destination, not just those used by PSF Direct host receivers. For the syntax of the **psfstat** command, see the *Infoprint Manager Reference*.

Displaying the Status of a PSF Direct Destination on the Host System

A host system operator can display the status of any printer managed by the host PSF program, including printers attached by PSF Direct. For example, an MVS operator can use the JES2 **\$DU** command to display printer status.

Using One Infoprint Actual Destination to Print Data from Multiple Sources

One Infoprint actual destination can print data from more than one host PSF program and from the IBM Infoprint Windows NT server. At any point in time, however, the Infoprint actual destination can only be dedicated to printing data from a single source: one host PSF program or the IBM Infoprint Windows NT server.

This topic describes how to configure and manage the switching of an Infoprint actual destination between data sources:

- [Switching between data sources](#)
- [Sharing an Infoprint actual destination](#)
- [Displaying the status of a shared Infoprint actual destination](#)

Switching between Data Sources

Switching an Infoprint actual destination between data sources requires two steps:

1. The PSF Direct host receiver using an Infoprint actual destination must end; or the Infoprint process printing from the IBM Infoprint Windows NT server must end. When this process ends, the Infoprint actual destination becomes available to another program.
2. A PSF Direct host receiver or Infoprint process that prints from the IBM Infoprint Windows NT server must wait for the Infoprint actual destination while it is used by another program.

Manually Stopping a PSF Direct Host Receiver

A host system operator can end a PSF Direct host receiver by ending the host PSF program that communicates with the host receiver.

For example, an MVS host operator can “purge” the printer using the **\$PPRT***nnn* JES2 command; or the operator can cancel the JES writer procedure.

To end the IBM Infoprint Windows NT server process manually from Infoprint, refer to the **pdshutdown** command as described in *Infoprint Manager Reference*. If you merely disable the printer through the **pddisable** command, the Infoprint processes are not stopped and the PSF Direct host receiver cannot establish a session.

For more detail about shutting down a PSF Direct host receiver, see [Stopping a PSF Direct Host Receiver](#).

Automatically Stopping a PSF Direct Host Receiver

Most host PSF programs have a “Disconnect Interval” configuration parameter, such as the **DISCINTV PRINTDEV** statement parameter in PSF/MVS. This parameter causes the host PSF program to end the SNA session with a PSF Direct host receiver if there is no data to print for the specified period. Ending the SNA session with the host receiver causes the host receiver to end.

Some host PSF programs, such as PSF/400, do not offer a “Disconnect Interval” configuration parameter. To enable PSF Direct host receivers to be automatically ended when they communicate with a host PSF program that does not offer a “Disconnect Interval” configuration parameter, the PSF Direct host receiver configuration panel includes an **Inactivity limit** parameter.

The PSF Direct host receiver **Inactivity limit** parameter causes a host receiver to end if it waits for data from the host system for the specified period.

Using the host PSF program's “Disconnect Interval” is preferable to using the PSF Direct host receiver **Inactivity limit** parameter.

Automatically Stopping Printing from the IBM Infoprint Windows NT Server

Each Infoprint actual destination has an actual destination attribute called the **printer-release-timer** attribute. This attribute causes Infoprint to stop printing from IBM Infoprint Windows NT Server if it has completed the Infoprint spool data and the specified interval elapses with no new IBM Infoprint Windows NT Server data.

Controlling the Wait Period for a PSF Direct Host Receiver

The PSF Direct host receiver **Device busy limit** parameter controls how long a host receiver waits for an Infoprint actual destination to become available. The **Device busy limit** parameter has a default value of 120 seconds. If an Infoprint actual destination is used to print from several sources, increase the **Device busy limit** parameter to 9999, which means that the host receiver should wait indefinitely.

While a PSF Direct host receiver is waiting for an Infoprint actual destination to become available, the SNA session with the host system is maintained but no application data is exchanged.

Controlling the Wait Period for Printing from an IBM Infoprint Windows NT Server

By default, the Infoprint program that prints from the IBM Infoprint Windows NT Server waits indefinitely for an Infoprint actual destination to become available. There is no configuration attribute that controls how long the program waits.

The following table summarizes the time limits for Infoprint printing:

Selected Time Limit Parameters				
For Device	Function	Option	User Interface	Default Value
PSF Direct Host Receiver	Wait for printer	Device Busy Limit field.	PSF Direct Receiver Manager window of Infoprint Manager Management Console .	120 seconds
PSF Direct Host Receiver	End program, making printer available.	DISCINTV	Host PSF configuration program	0 seconds (infinite)
PSF Direct Host Receiver	End program, making printer available.	Inactivity limit field.	PSF Direct Receiver Manager window of Infoprint Manager Management Console .	9999 seconds (infinite)
IBM Infoprint Windows NT Server	Wait for printer	none	none	infinite
IBM Infoprint Windows NT Server	End program, making printer available.	printer-release-timer attribute	On the Infoprint Manager Administration GUI , the PSF Configuration tab of the Printer Notebook .	9999 seconds (infinite)

Sharing an Infoprint Actual Destination: An Example

The following example illustrates how an Infoprint actual destination could be shared between two host PSF programs using PSF Direct and also print data from the IBM Infoprint Windows NT Server.

The configuration parameters cause the printer to be switched automatically.

This section consists of the following topics:

- [Host PSF Program Configuration: Examples](#)
- [Infoprint Actual Destination: PSF Tuning Options](#)
- [PSF Direct Host Receiver: Examples](#)

Host PSF Program Configuration: Examples

For two host PSF programs to share an Infoprint actual destination, they must specify similar **PRINTDEV** statements. Note that the colon (:) indicates that the complete statement would contain more parameters.

Selected PSF/MVS **PRINTDEV** parameters:

```
// PRT833 PRINTDEV
:
//          DISCINTV=60 ,          /*DISCONNECT INTERVAL -- SECONDS
          */
::
// PRT833 ENDCNTL
```

Selected PSF/VSE **PRINTDEV** parameters:

```
    PRT100
    0 PRINTDEV
:
          DISCINTV=60 ,          DISCONNECT INTERVAL -- SECONDS
::
```

Setting the **DISCINTV** to 60 seconds for both host PSF programs causes each host PSF program to end if all spool data from the printer is completed and no additional data becomes available for 60 seconds. When the host PSF program ends, the PSF Direct host receiver ends, and the Infoprint actual destination becomes available to other programs.

If additional host data becomes available for the Infoprint actual destination, the host PSF program starts again and waits, if necessary, for the printer to become available.

Infoprint Actual Destination: PSF Tuning Options

To allow Infoprint to share the printer with two host PSFs, you must adjust the Infoprint actual destination's PSF tuning options from the **Printer Properties** in the **Infoprint Manager Administration GUI**.

Select the actual destination (printer) you want to configure, then use the **Printer-->Properties** menu to open the **Printer Properties** notebook, select the **Tuning** tab, and tune the options described in this section.

The **Release time (sec)** field (or **destination-release-timer** attribute) specifies the amount of time between jobs (in seconds) that Infoprint waits before giving up control of an actual destination. Setting this value to 60 seconds causes the Infoprint program that prints from the IBM Infoprint Windows NT server to end if it has printed the files in the printer's queue and no additional files become available for 60 seconds. When the program ends, the Infoprint actual destination becomes available to other programs such as PSF Direct receivers.

If additional files are added to the printer's queue on the IBM Infoprint Windows NT server, the Infoprint program that prints from the server starts again and waits, if necessary, for the printer to become available.

Accepting the default **intervention-timer** attribute value of 9999 causes the PSF Direct host receivers that use this printer to issue printer intervention messages on the Windows NT system, but not to report intervention conditions to the host PSF program.

If an **intervention-timer** value of 3600 were used instead, the PSF Direct receivers that use this printer would notify the host PSF program if an intervention condition were not addressed within an hour. The host PSF program would issue an operator message and end the SNA session with the PSF Direct receiver. The **intervention-timer** would also cause the PSF program that prints from the IBM Infoprint Windows NT server to end if an intervention condition were not addressed within an hour.

For continuous-forms printers, set the **Non-process-runout-timer** field at a lower value than what is set for the **Release-time (sec)** attribute. For example, if the `destination-release-timer = 60` seconds, the `non-process-runout-timer` attribute should be reduced to 30 seconds.

PSF Direct Host Receiver: Examples

Finally, you must configure the PSF Direct host receivers for each host that will share the printer. This process is described in [Defining the PSF Direct Host Receiver](#).

Sample PSF Direct host receiver values for a PSF/MVS host:

SNA Logical Unit Name	MVS1
Target Destination (actual destination)	4000wb
Inactivity limit (seconds)	9999
Device busy limit (seconds)	9999
SNA System Services Control Point ID	050000000000
NMVT Subsystem Name	NMVT

Sample PSF Direct host receiver values for a PSF/MVS host:

SNA Logical Unit Name	VSE1
Target Destination (actual destination)	4000wb
Inactivity limit (seconds)	9999
Device busy limit (seconds)	9999
SNA System Services Control Point ID	050000000000
NMVT Subsystem Name	NMVT

Displaying the Status of a Shared Infoprint Actual Destination

The **psfstat** command displays information about the status of Infoprint actual destinations and PSF Direct receivers. The information **psfstat** displays about an Infoprint actual destination includes the program that currently controls the printer and a list of the programs waiting to gain control of the printer.

For example, **psfstat** might display the following:

```

Printer Attachment  Data  Printer
                  status
-----  -----  -----
4000wb  TCP/IP      IPDS  intervention  MVS1
                  [Queue],VSE1

```

```

LU name Printer      Atta
                  chme Data
                  nt
-----  -----  ----
MVS1    4000wb      TCP/
                  IP  IPDS      interventi
                  on  sess/prtr_con
VSE1    4000wb      TCP/
                  IP  IPDS      interventi
                  on  sess/prtr_bus

```

This **psfstat** output shows that the printer is currently dedicated to printing data from the MVS spool. There is also data on the IBM Infoprint Windows NT server ([Queue]) and the VSE spool waiting to print.

When the MVS host system releases the printer, the printer will print data either from the IBM Infoprint Windows NT server or the VSE host system. The order in which the two waiting sources are listed does not imply that the IBM Infoprint Windows NT server has been waiting longer or will acquire the printer next.

The **psfstat** output also indicates that the printer requires intervention.

For more information about the **psfstat** command, see both [Displaying the Status of a PSF Direct Destination on NT](#) and the *Infoprint Manager Reference*.

