

IBM Network Color Printer



# Installation and Relocation

**Note**

Before using this information and the product it supports, be sure to read the general information under "Notices" on page v.

### **Third Edition (November 1996)**

This edition applies to the *Network Color Printer Installation and Relocation Guide*, G544-5362-02.

The following paragraph does not apply to any country where such provisions are inconsistent with local law.

INTERNATIONAL BUSINESS MACHINES CORPORATION PROVIDES THIS PUBLICATION "AS IS" WITHOUT WARRANTY OF ANY KIND, EITHER EXPRESS OR IMPLIED, INCLUDING, BUT NOT LIMITED TO THE IMPLIED WARRANTIES OF MERCHANTABILITY OR FITNESS FOR A PARTICULAR PURPOSE. Some states do not allow disclaimer of express or implied warranties in certain transactions, therefore, this statement may not apply to you.

Order publications through your IBM representative, your IBM Printing Systems Company printing specialist, or the IBM branch office serving your locality. Publications are not stocked at the address given below.

IBM and the IBM Printing Systems Company welcome your comments. A reader's comment form is provided at the back of this publication. Either fax your comments to 1-303-924-5944, e-mail them to [print\\_pubs@vnet.ibm.com](mailto:print_pubs@vnet.ibm.com), or mail them to:

IBM Printing Systems Company  
Department H7FE, Building 003G  
Information Development  
P.O. Box 1900  
Boulder, CO 80301-9191, U.S.A.

When you send information to IBM, you grant IBM a non-exclusive right to use or distribute the information in any way it believes appropriate without incurring any obligation to you.

© **Copyright Electronics for Imaging 1996.**

© **Copyright International Business Machines Corporation 1996. All rights reserved.**

Note to U.S. Government Users — Documentation related to restricted rights — Use, duplication or disclosure is subject to restrictions set forth in GSA ADP Schedule Contract with IBM Corp.

---

# Contents

<b>Notices</b> . . . . .	v
Trademarks . . . . .	vi
Communications Statements . . . . .	vii
Federal Communication Notices Commission (FCC) Statement . . . . .	vii
European Union (EU) Electromagnetic Conformity Statement . . . . .	vii
Safety Notices . . . . .	viii
DANGER Notices . . . . .	viii
Caution Notices . . . . .	viii
Attention Notice . . . . .	viii
Safety Precautions . . . . .	ix
Electrical Safety . . . . .	ix
Laser Safety . . . . .	ix
Disposal of Materials . . . . .	ix
<b>Preface</b> . . . . .	xi
Related Publications . . . . .	xi
<b>Chapter 1. Installation</b> . . . . .	1-1
Establishing the Printer Environment . . . . .	1-1
Operating Space . . . . .	1-1
Temperature and Humidity . . . . .	1-1
Electrical Requirements . . . . .	1-1
Weight of the Printer . . . . .	1-2
Other Considerations . . . . .	1-2
Preparing for Installation . . . . .	1-2
Checking the Package Contents . . . . .	1-3
Preparing to Install the Printer . . . . .	1-4
Setting Up the Optional Printer Stand . . . . .	1-4
Setting Up the Optional Tray 2 Paper Feeder . . . . .	1-5
Installing the Printer . . . . .	1-6
Installing the Printer on the Optional Tray 2 Paper Feeder . . . . .	1-6
Installing the Printer on the Optional Printer Stand . . . . .	1-7
Installing the Printer on a Table . . . . .	1-8
Completing the Printer Installation . . . . .	1-8
Installing Supplies . . . . .	1-9
Photoconductor Drum Cartridge . . . . .	1-9
Used Toner Bottle . . . . .	1-11
Toner Cartridges . . . . .	1-11
Inserting Toner Cartridges . . . . .	1-11
Fuser Oil Bottle . . . . .	1-14
Upgrading the Controller Memory Configuration . . . . .	1-15
Electrostatic Discharge Procedures . . . . .	1-15
SIMM Identification and Location . . . . .	1-16
How to Remove a SIMM . . . . .	1-16
How to Install a SIMM . . . . .	1-16
Removing the Controller . . . . .	1-17
Configuring the SIMMs . . . . .	1-17
16MB SIMM Configuration . . . . .	1-18
32MB SIMM Upgrade from 16MB Configuration . . . . .	1-19
48MB SIMM Upgrade from 16MB Configuration . . . . .	1-20

48MB SIMM Upgrade from 32MB Configuration . . . . .	1-21
Reinstalling the Controller . . . . .	1-22
Connecting the Power Cords . . . . .	1-22
Printing a Test Page . . . . .	1-24
Printer Configuration . . . . .	1-24
<b>Chapter 2. Relocation . . . . .</b>	<b>2-1</b>
Preparation . . . . .	2-1
Disposing of Materials . . . . .	2-2
Turning Off the Printer . . . . .	2-2
Disconnecting the Power Cord . . . . .	2-2
Removing Paper . . . . .	2-3
Removing the Four Toner Cartridges . . . . .	2-4
Removing the Photoconductor Drum Cartridge . . . . .	2-5
Removing the Fuser Oil . . . . .	2-7
Preparing the Work Area . . . . .	2-7
Removing the Oil . . . . .	2-7
Taping the Printer . . . . .	2-10
Removing the Printer . . . . .	2-11
Removing the Optional Tray 2 Paper Feeder . . . . .	2-11
Taping the Optional Paper Stand . . . . .	2-11
Packing the Printer . . . . .	2-12

---

## Notices

References in this publication to IBM products, programs or services do not imply that IBM intends to make these available in all countries in which IBM operates. Any reference to an IBM licensed product, program, or service is not intended to state or imply that only IBM's product, program, or service may be used. Any functionally equivalent product, program, or service that does not infringe any of IBM's intellectual property rights may be used instead of the IBM product. Evaluation and verification of operation in conjunction with other products, except those expressly designated by IBM, is the user's responsibility.

Any performance data contained in this document was obtained in a controlled environment based on the use of specific data. The results that may be obtained in other operating environments may vary significantly. Users of this document should verify the applicable data in their specific environment. Therefore, such data does not constitute a performance guarantee or warranty.

IBM may have patents or pending patent applications covering subject matter in this document. The furnishing of this document does not give you any license to these patents. You can send license inquiries, in writing, to the IBM Corporation, IBM Director of Licensing, 208 Harbor Drive, Stamford, Connecticut, United States, 06904.

---

## Trademarks

The following terms are trademarks of the IBM Corporation in the United States or other countries or both:

AIX®  
AIX/6000®  
IBM®  
OS/2®  
Personal System/2®  
PS/2®  
RISC System/6000®  
WIN-OS/2

The following terms are trademarks or registered trademarks of other companies:

Acrobat	Adobe Systems, Inc.
Adobe	Adobe Systems, Inc.
Adobe logo	Adobe Systems, Inc.
Adobe Separator	Adobe Systems, Inc.
Adobe Type Manager	Adobe Systems, Inc.
Apple®	Apple Computer, Inc.
Apple logo	Apple Computer, Inc.
Apple Talk®	Apple Computer, Inc.
Agfa®	Afga-Gevaert A.G.
AXIS®	AXIS Communication, Inc.
EPS (Encapsulated PostScript)	Altsys Corporation
Ethernet	Xerox Corporation
EtherTalk®	Applelice Computer, Inc.
Fiery	Electronics for Imaging, Inc.
Fiery Driven	Electronics for Imaging, Inc.
Fiery XJ	Electronics for Imaging, Inc.
Fiery logo	Electronics for Imaging, Inc.
IPX (Internetwork Packet Exchange)	Novell, Inc.
ITC Advant Garde Gothic®	International Typeface, Inc.
ITC Bookman®	International Typeface, Inc.
ITC Zapf Chancery®	International Typeface, Inc.
ITC Zapf Dingbat®	International Typeface, Inc.
Macintosh®	Apple Computer, Inc.
Microsoft®	Microsoft Corp.
NetWare®	Novell, Inc.
Novell®	Novell, Inc.
PageMaker	Adobe Systems, Inc.
PANTONE®	Pantone, Inc.
PostScript	Adobe Systems, Inc.
QuarkXPress®	Quark, Inc.
TrueType	Apple Computer, Inc.
Univers®	Linotype AG and Subsidiaries
UNIX®	AT&T Corporation
Windows	Microsoft Corp.

---

## Communications Statements

### Federal Communication Notices Commission (FCC) Statement

This equipment has been tested and found to comply with the limits for a Class B digital device, pursuant to Part 15 of the FCC Rules. These limits are designed to provide reasonable protection against harmful interference in a residential installation. This equipment generates, uses, and can radiate radio frequency energy and, if not installed and used in accordance with the instructions, may cause harmful interference to radio communications. However, there is no guarantee that interference will not occur in a particular installation. If this equipment does cause harmful interference to radio or television reception, which can be determined by turning the equipment off and on, the user is encouraged to try to correct the interference by one or more of the following measures:

- Reorient or relocate the receiving antenna.
- Increase the separation between the equipment and receiver.
- Connect the equipment into an outlet on a circuit different from that to which the receiver is connected.
- Consult an IBM authorized dealer or service representative for help.

Properly shielded and grounded cables and connectors (IBM part number 68X3949 or its equivalent for PC parallel) must be used in order to meet FCC emission limits. Proper cables and connectors are available from IBM authorized dealers. IBM is not responsible for any radio or television interference caused by using other than recommended cables and connectors or by unauthorized changes or modifications to this equipment. Unauthorized changes or modifications could void the user's authority to operate the equipment.

This device complies with Part 15 of the FCC Rules. Operation is subject to the following two conditions: (1) this device may not cause harmful interference, and (2) this device must accept any interference received, including interference that may cause undesired operation.

### European Union (EU) Electromagnetic Conformity Statement

This product is in conformity with the protection requirements of EU Council Directive 89/336/EEC on the approximation of the laws of the Member States relating to electromagnetic compatibility. IBM cannot accept responsibility for any failure to satisfy the protection requirements resulting from a non-recommended modification of the product, including the fitting of non-IBM option cards.

**EU Conformity Statement:** This product has been tested and found to comply with the limits for Class B Information Technology Equipment according to CISPR 22/European standard EN 55022. The limits for Class B equipment were derived for typical environments to provide reasonable protection against interference with licensed communication devices.

**German Conformity Statement:** Dieses Gerät erfüllt die Bedingungen der EN 55022 Klasse B.

**Industry Canada Compliance Statement:** This Class B digital apparatus meets the requirements of the Canadian Interference-causing equipment regulations. Cet appareil numérique de la classe B respecte toutes les exigences du Règlement sur le matériel brouiller du Canada.

**Japanese VCCI Class 2 ITE Statement.**

この装置は、第二種情報処理装置（住宅地域又はその隣接した地域において使用されるべき情報処理装置）で住宅地域での電法障害防止を目的とした情報処理装置等電波障害防止技術協議会（VCCI）基準に適合しております。

しかし、本装置をラジオ、テレビジョン受信機に近接してご使用になると、受信障害の原因となることがあります。

取扱説明書に従って正しい取り扱いをして下さい。

vccib

---

## Safety Notices

There are three levels of safety notices: **DANGER**, **CAUTION**, and **Attention**.

### DANGER Notices

A **DANGER** notice calls attention to a possible lethal condition. **DANGER** notices are numbered <1-1>, <1-2>, and so forth where they appear in the text of this manual. Use the notice number to locate the national language translation of that notice in *IBM Network Color Printer: Safety Information, G544-5352*.

### Caution Notices

A **CAUTION** notice calls attention to a possible hazard to people. **CAUTION** notices are numbered <2-1>, <2-2>, and so forth where they appear in the text of this manual. Use the notice number to locate the national language translation of that notice in *IBM Network Color Printer: Safety Information, G544-5352*.

### Attention Notice

An **Attention** notice warns of possible of damage to a program, device, system, or data. **Attention** notices are located throughout this publication. Attention notices are not translated.



---

## Safety Precautions

### Electrical Safety

This printer is inspected and listed by recognized national testing laboratories, such as Underwriters Laboratories, Inc. (UL) in the U.S.A. and Canadian Standards Association (CSA) in Canada. Listing of a product by a national testing laboratory indicates that the product is designed and manufactured in accordance with national requirements intended to minimize safety hazards. IBM equipment meets a very high standard of safety in design and manufacture. Remember, however, that this product operates under conditions of high electrical potentials and heat generation, both of which are functionally necessary.

Because the paper and toner used in the printer can burn, you should take normal precautions to prevent fire. These precautions include common-sense measures, such as keeping potentially combustible materials (for example, curtains and chemicals) away from the printer, providing adequate ventilation and cooling, limiting unattended operation, and having trained personnel available and assigned to the printer.

### Laser Safety

This printer complies with the performance standards set by U.S. Food and Drug Administration for a Class 1 Laser Product. This means that the printer belongs to a class of laser products that does not produce hazardous laser radiation in a customer access area. This classification was accomplished by providing the necessary protective housing and scanning safeguards to ensure that laser radiation is inaccessible or within Class 1 limits.

There are various tool-operated machine covers that should be moved, removed, or replaced only by trained service personnel. There are no operator controls or adjustments associated with the laser.

No operator maintenance is required to keep the product in compliance as a Class 1 Laser Product. No adjustments that affect laser operation or power are accessible to the operator.

**Note:** See *IBM Network Color Printer: Safety Information, G544-5352*, for national language translations regarding laser safety.

### Disposal of Materials

#### **CAUTION:**

**This printer may contain materials, either components or consumable supplies, that are regulated for disposal. Dispose of all items in accordance with local regulations.**



---

## Preface

IBM has prepared this document to guide you through either installing or relocating the IBM Network Color Printer. This publication is not meant for any other purpose. Refer to *IBM Network Color Printer: Administrator's Guide*, S544-5364 for system and network attachment instructions.

---

## Related Publications

The following books provide additional information about the IBM Network Color Printer:

*IBM Network Color Printer: Installation and Operation Video*

*IBM Network Color Printer: Quick Print Guide* (softcopy only)

*IBM Network Color Printer: Operator's Guide*, S544-53 61

*IBM Network Color Printer: Administrator's Guide*, S544-5364

*IBM Network Color Printer: User's Guide*, S544-5363

*IBM Network Color Printer: Maintenance Information Manual*, S544-5365

*IBM Network Color Printer: Safety Information*, G544-5352



# Chapter 1. Installation

These procedures guide you through the following:

- Establishing a suitable printing environment
- Preparing to install the printer
- Installing the printer
- installing printer supplies
- Upgrading the controller memory configuration
- Connecting power
- Printing test pages
- Locating configuration information

An installation and operation video, included in the shipping package, demonstrates the proper procedures for installing and operating the printer. Take a few minutes before beginning this section to view this video.

The printer shipping package also contains the necessary printer publications, instructions, driver software, and start-up supplies for getting the printer up and running.

The optional printer stand and the optional tray 2 paper feeder are each shipped in a separate box.

If you require assistance during installation or prefer that an IBM service representative install your printer, please call your authorized service dealer or IBM at 1-800-358-6661 (U.S. and Canada).

## Establishing the Printer Environment

To ensure high-quality operation, the following environmental conditions and requirements should exist:

- Adequate operating space
- Correct operating temperature and humidity
- Correct electrical supply
- Strong printer stand or table
- Other considerations

## Operating Space

Verify that the minimum space requirements as shown below, are met.

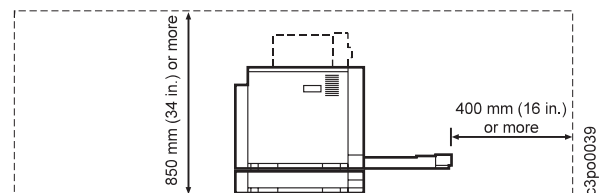
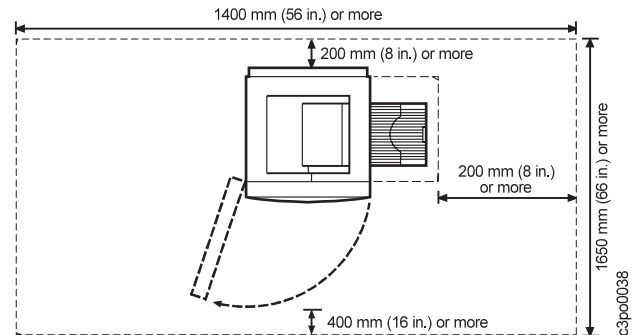

## Temperature and Humidity

Make sure that the following environmental conditions exist:

- Room temperature of 15–32.5°C (60–90°F)
- Relative humidity of 20–80%
- Adequate ventilation

## Electrical Requirements

<1-1> DANGER

**This procedure should be performed by either a qualified service representative, or a qualified electrician.**

The supply voltage should be within one of the following two specifications:

- 100/120 V ac 50Hz/60Hz, 10 amps
- 220/240 V ac 50Hz/60Hz, 5 amps

**Note:** Do not connect the printer to an extension cord.

## Weight of the Printer

<2-7> CAUTION:

The printer weighs approximately 50 kg (110 lb). You need at least two people to move the printer.

The surface on which the printer will be installed should be flat, level, and strong enough to support the weight of the printer, 50 kg (110 lb), plus that of any additional items that may be placed there.

## Other Considerations

Do not place the printer in any of the following environments:

- In direct sunlight
- Near magnets or magnetic fields
- Near open flames or water
- In a dusty location
- Where there is vibration

---

## Preparing for Installation

Perform the following activities before installing the IBM Network Color Printer:

- To avoid temporary problems caused by moisture, allow sufficient time for the printer to stabilize in the environment of the room before continuing with the unpacking.
- Make sure that you have the following publications:
  - *IBM Network Color Printer: Installation and Operation Video*
  - *IBM Network Color Printer: Operator's Guide, S5445361*
  - *IBM Network Color Printer: Administrator's Guide, S5445364*
  - *IBM Network Color Printer: User's Guide, S5445363*
  - *IBM Network Color Printer: Safety Information, G544-5352*

# Checking the Package Contents

Make sure that the items shown here are included in the printer shipping package.

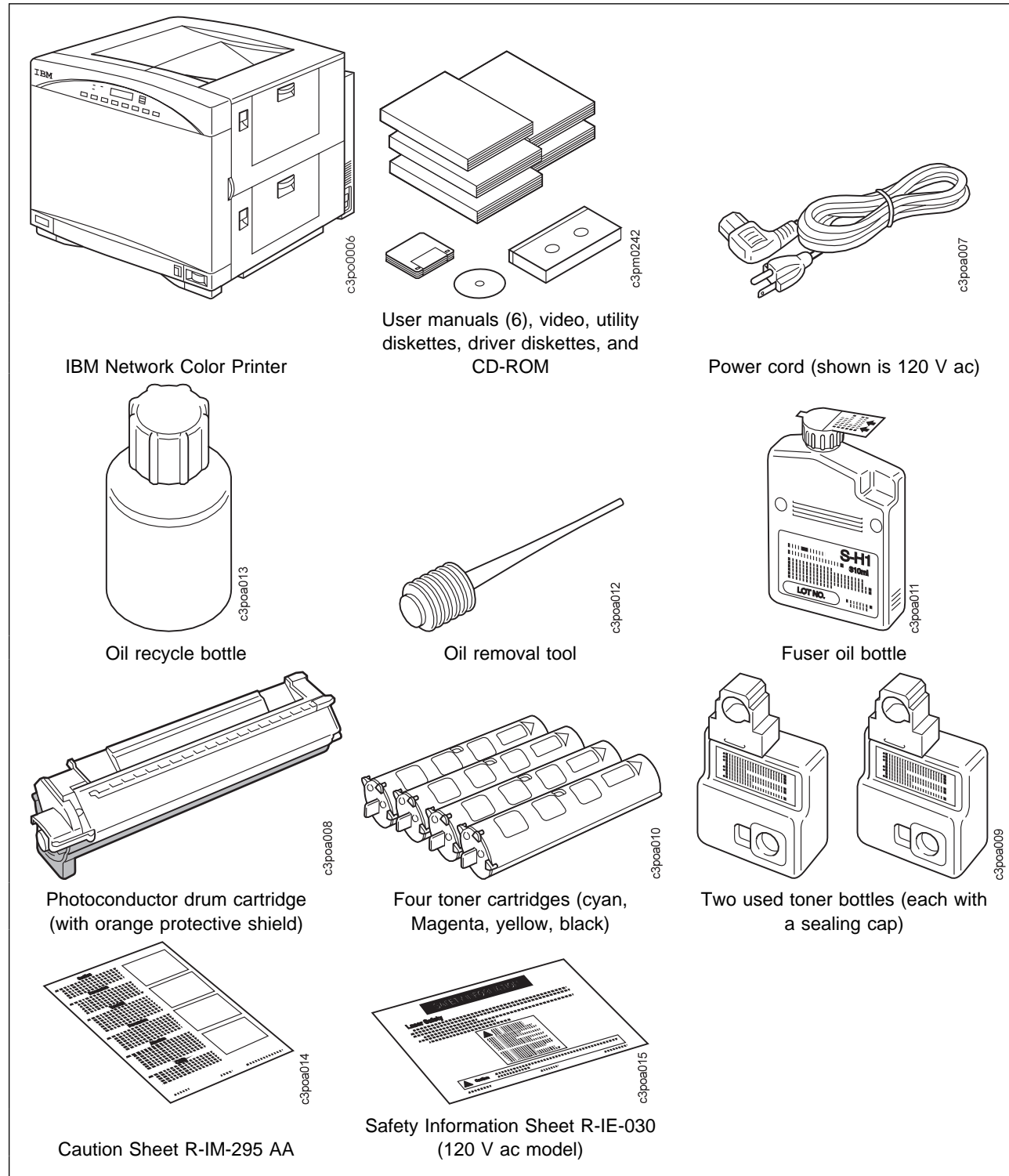

## Preparing to Install the Printer

In the following procedures, you will prepare the optional printer stand or a table for the printer. If you purchased the optional tray 2 paper feeder, you will set it either on the printer stand or on a table.

*Do not move the printer until instructed to do so.*

If you purchased the printer with the optional printer stand *and* the optional tray 2 paper feeder, perform the following:

1. Setting Up the Optional Printer Stand
2. Setting Up the Optional Tray 2 Paper Feeder
3. "Installing the Printer" on page 1-6

If you purchased the printer and *only* the optional tray 2 paper feeder, perform the following:

1. Setting Up the Optional Tray 2 Paper Feeder
2. "Installing the Printer" on page 1-6

If you purchased the printer and *only* the optional printer stand, perform the following:

1. Setting Up the Optional Printer Stand
2. "Installing the Printer" on page 1-6

If you are installing the printer on a table *without* the optional tray 2 paper feeder, perform the following:

- "Installing the Printer" on page 1-6

## Setting Up the Optional Printer Stand

1. Unpack the optional printer stand.
2. There are two locating pins shipped with the printer stand. Make sure that the pins are positioned as follows:
  - If you are installing the optional tray 2 paper feeder on the stand, both pins should be in front.
  - If you are installing just the printer on the stand, move the left front pin to the left rear hole.

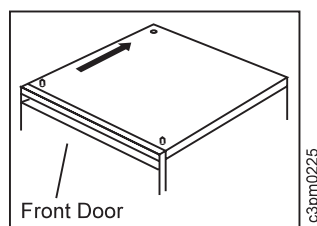

3. Make sure that the caster locks on the front wheels of the printer stand are unlocked.
4. Locate the stand near the printer to ease printer installation.
5. Lock the caster locks on the front wheels of the printer stand to prevent the stand from moving when you install the printer. The stand can be rolled into place after the printer is installed on the stand.

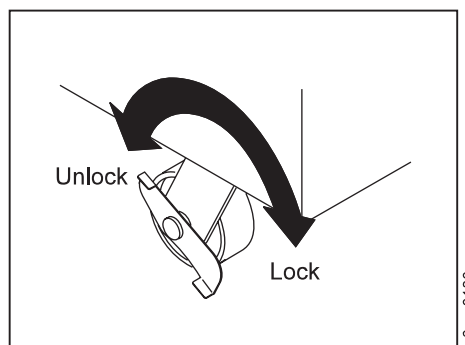

If you purchased the optional tray 2 paper feeder, go to Setting Up the Optional Tray 2 Paper Feeder next. Otherwise, go to "Installing the Printer" on page 1-6.



## Setting Up the Optional Tray 2 Paper Feeder

1. Unpack the optional tray 2 paper feeder.
2. If you purchased the optional printer stand, perform the following:
  - a. Align the front of the optional tray 2 paper feeder with the front door of the printer stand.
  - b. Set the optional tray 2 paper feeder on the stand, aligning the holes in the right and left front feet with the 2 locating pins on the top of the stand.

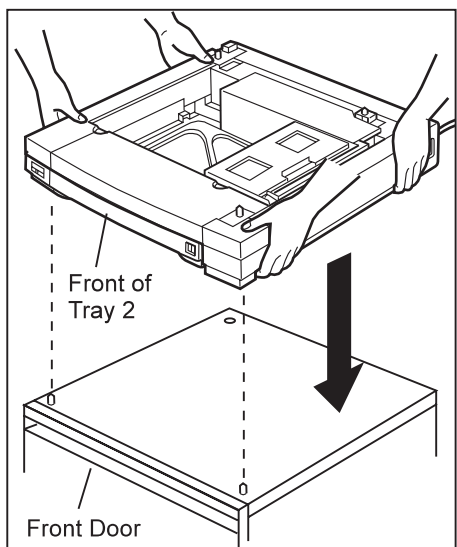

3. If you are installing the printer on a table, set the optional tray 2 paper feeder on the table.
4. Remove the shipping tape and the bag containing the 2 locking pins from the optional tray 2 paper feeder. You will use these locking pins later to lock the printer onto the paper feeder.

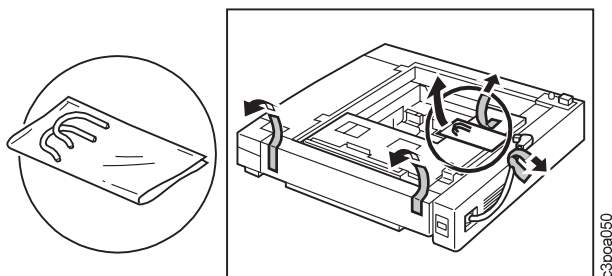

5. Push up on the paper handle on the underside of the tray and pull out and remove the tray.

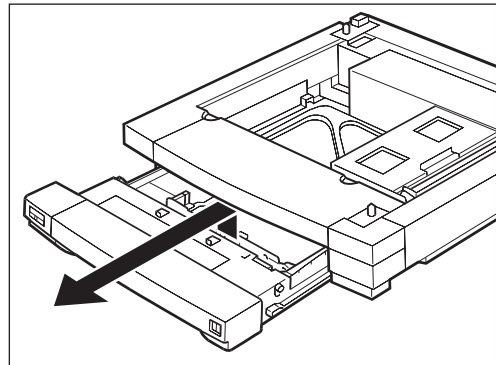

6. Remove the shipping spacers **1** and **2** (shipping spacers may vary).

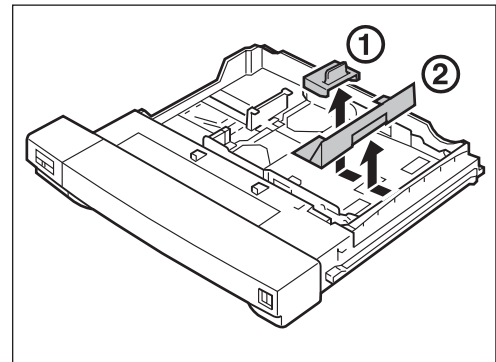

7. Invert the tray and remove the shipping spacer 1 and all of the tape from the bottom of the tray.

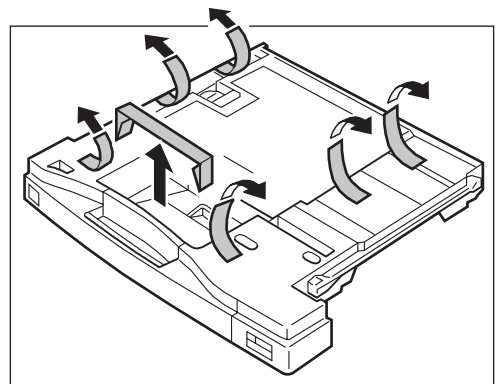

8. Reinstall the tray.
9. Go to "Installing the Printer" on page 1-6 and install the printer.

## Installing the Printer

### <2-7> CAUTION:

The printer weighs approximately 50 kg (110 lb). You need at least two people to move the printer.

1. Open the plastic bag that protects the printer and slide it down as far as possible. *Do not move the printer yet.*
2. Before you move the printer, note the following:
  - a. The right side of the printer (as viewed from the front) is heavier than the left side (in Figure 9, the shaded portion represents the heavier side).
  - b. When you grip the printer, use only the recessed gripping slots **1**, **2**, **3**, and **4** as shown below. Locate these slots.

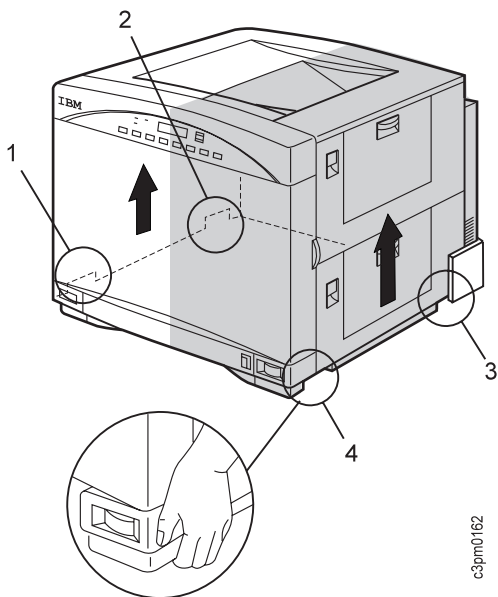

- c. Make sure that the recessed gripping slots are accessible for a firm grip.
- d. Plan how you will move and place the printer so that printer tray 1 aligns with one of the following:
  - Tray 2 of the optional tray 2 paper feeder
  - The front door of the optional printer stand

## Installing the Printer on the Optional Tray 2 Paper Feeder

The optional tray 2 paper feeder may be placed on either the optional printer stand or on a table.

### <2-7> CAUTION:

The printer weighs approximately 50 kg (110 lb). You need at least two people to move the printer.

1. Make sure that you understand Step 2 under "Installing the Printer."
2. Set the printer on the tray 2 paper feeder, aligning the hole in the right front foot with the right front locating pin, and the hole in the left rear foot with the left rear pin. The third pin aligns with a hole near the right rear corner of the printer.

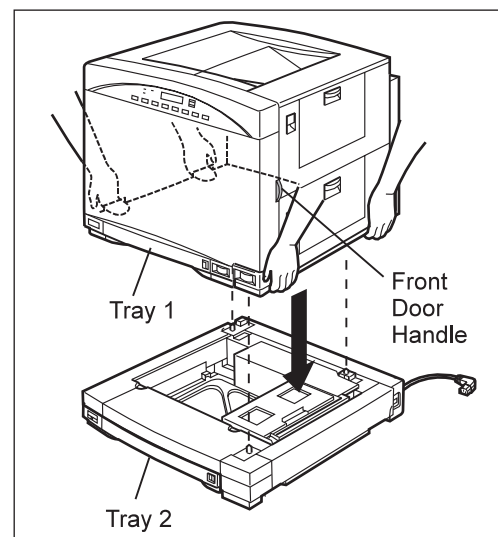

3. Install the locking pins that you unpacked in Step 4 on p. 5, locking the printer in place.

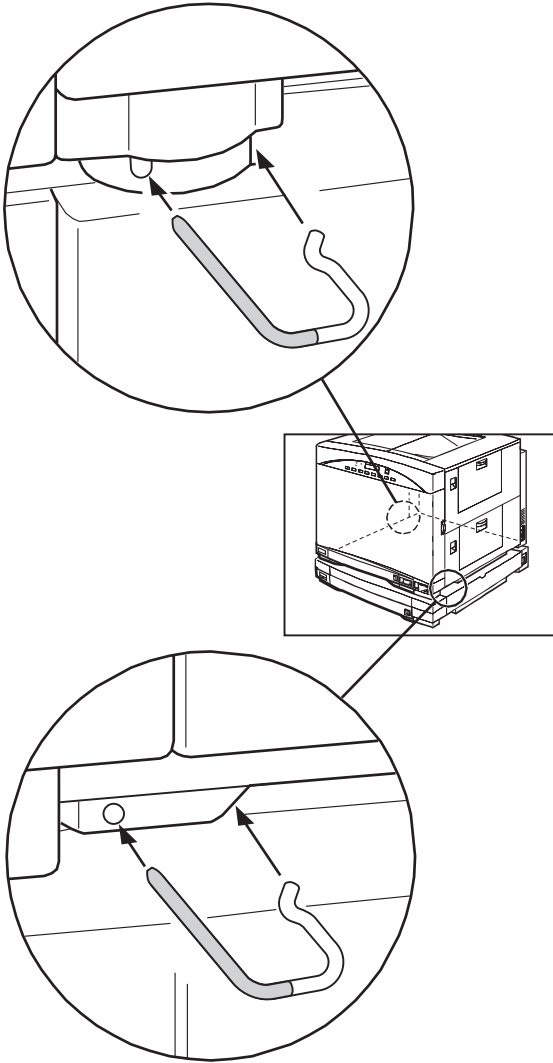

**<2-8> CAUTION:**

The printer weighs approximately 50 kg (110 lb). When you move the printer stand, be careful that the wheels do not hit something and cause the printer to fall.

4. If you install the printer and optional tray 2 paper feeder on the optional printer stand, unlock the caster locks and carefully roll the unit into position.
5. Lock the caster locks and adjust the leveling foot on each leg of the printer stand as required.

## Installing the Printer on the Optional Printer Stand

**<2-7> CAUTION:**

The printer weighs approximately 50 kg (110 lb). You need at least two people to move the printer.

1. Make sure that you understand Step 2 on page 1-6.
2. Make sure that you have positioned the locating pins in the top of the stand as described in "Setting Up the Optional Printer Stand" on page 1-4.
3. Set the printer on the optional printer stand, aligning the hole in the right front foot and the hole in the left rear foot with the locating pins on the printer stand.

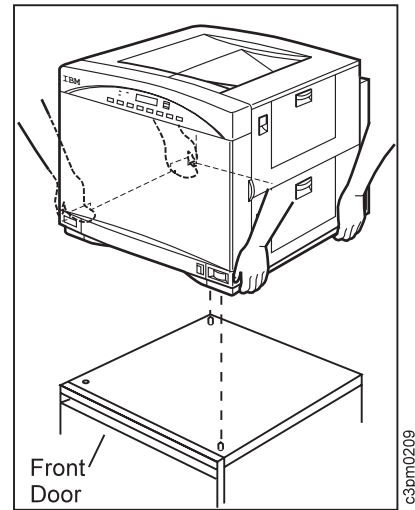

**<2-8> CAUTION:**

The printer weighs approximately 50 kg (110 lb). When you move the printer stand, use care that the wheels do not hit something and cause the printer to fall.

4. Unlock the caster locks.
5. Carefully roll the unit into position.
6. Lock the caster locks.
7. Adjust the leveling foot on each leg of the printer stand as required.

## Installing the Printer on a Table

### <2-7> CAUTION:

The printer weighs approximately 50 kg (110 lb). You need at least two people to move the printer.

1. Make sure that you understand Step 2 on page 1-6.
2. Make sure that the table meets the weight requirements listed under “Weight of the Printer” on page 1-2.
3. Set the printer on the table.

## Completing the Printer Installation

1. Remove the external shipping tape from the printer.
2. Remove the protective film covering the display panel.
3. Open the printer front door and remove all shipping tape and packing.

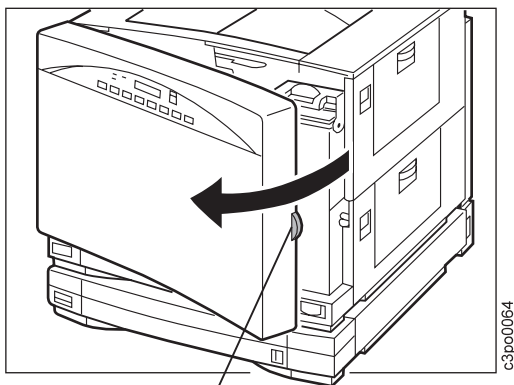

Door Handle

c3po0064

4. Loosen the screw securing the orange REMOVE tag, and then lift up on the screw and tag, and pull them out. Save the screw, tag, and spacer to use if you relocate the printer.

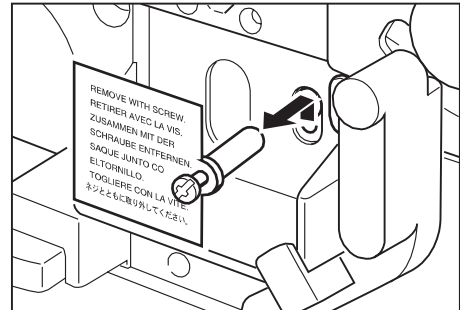

c3poa033

5. Pull up on the release latch **1** and open the fuser access door.

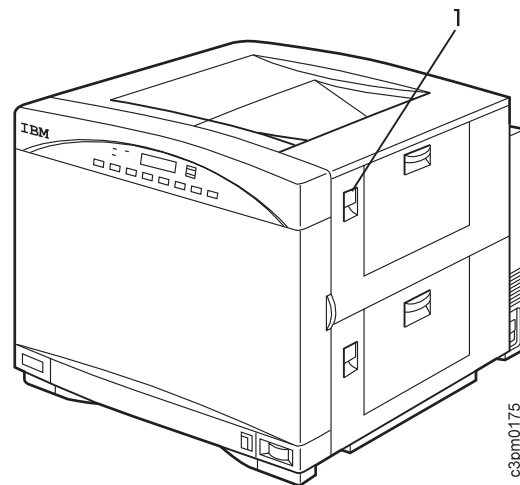

c3pm0175

6. Remove the right and left orange pressure release spacers. Save the spacers to use if you relocate the printer.

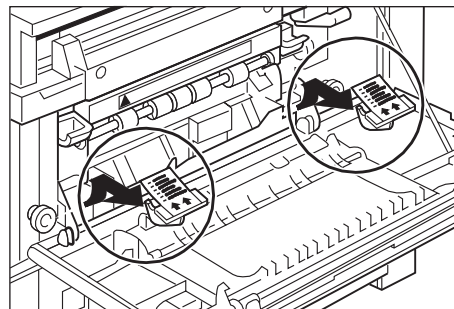

c3poa035

7. Close the fuser access door.

8. Go to the front of the printer. Push up the handle on the underside of tray1 and pull out and remove the tray.

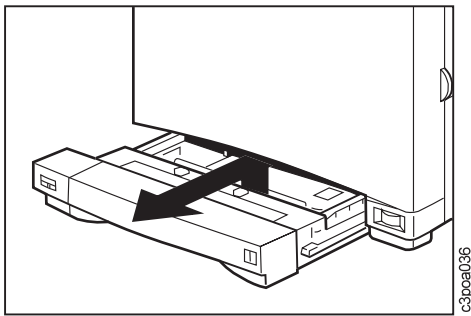

9. Remove the shipping tape and the shipping spacer from the top of the tray and the tape from the bottom of the tray. Reinstall the tray.

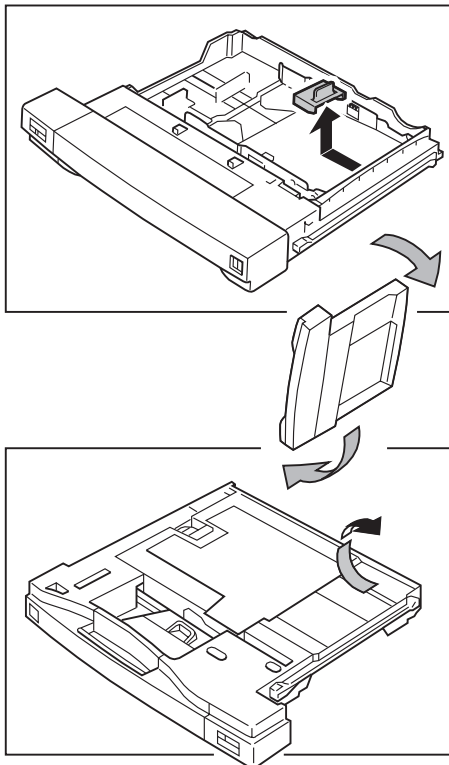

## Installing Supplies

In the following procedures, you will install the photoconductor drum cartridge, the used toner bottle, the four toner cartridges, and the fuser oil bottle. *Install these items in the order listed.*

See *IBM Network Color Printer: Operator's Guide* for information about storing supplies.

### Photoconductor Drum Cartridge

When you change the photoconductor drum cartridge, you should also change the used toner bottle.

1. Open the printer front door.
2. Push down on the release handle.

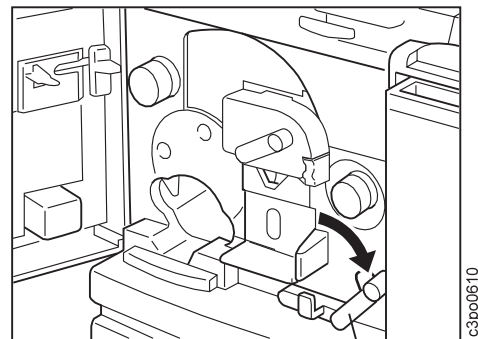

Release Handle

3. Open the photoconductor drum cover.

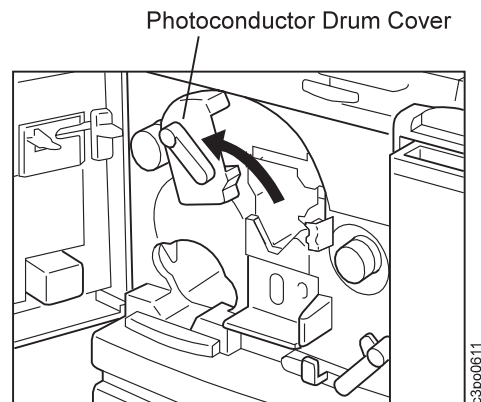

Photoconductor Drum Cover

4. Remove the photoconductor drum cartridge from the protective bag. Do not remove the orange protective shield until you are instructed to do so.
5. Use the arrow on the cartridge as a guide to align the photoconductor drum cartridge with the arrow on the printer. The orange photoconductor drum shield rests on a V-shaped cutout on the printer. The top of the cartridge aligns with the 2 rails.

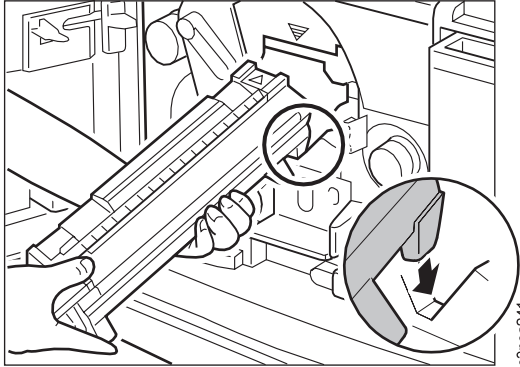

c3poa241

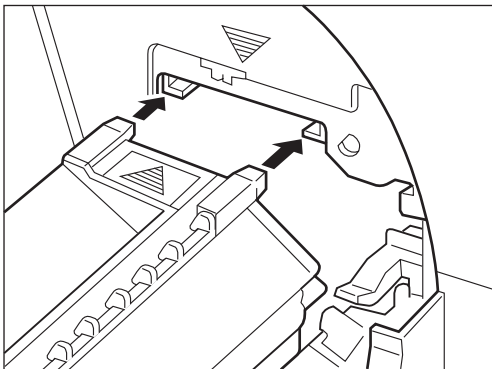

c3poa243

6. Hold the orange shield with one hand. Slowly slide the cartridge along the orange shield into the printer with the other hand until the green tab on the cartridge locks in place. Keep the orange shield for use later when you remove the photoconductor drum cartridge.

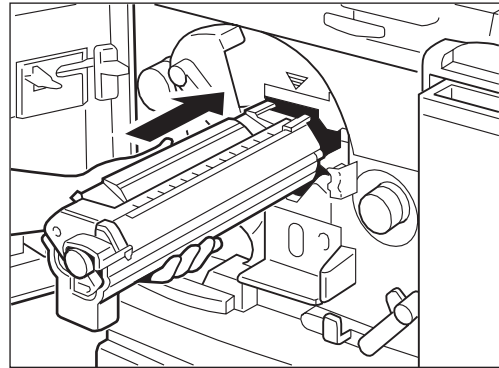

c3poa242

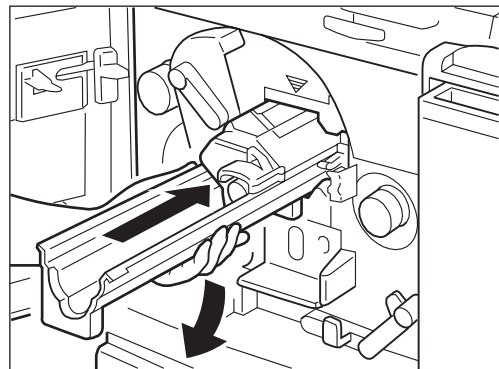

c3poa244

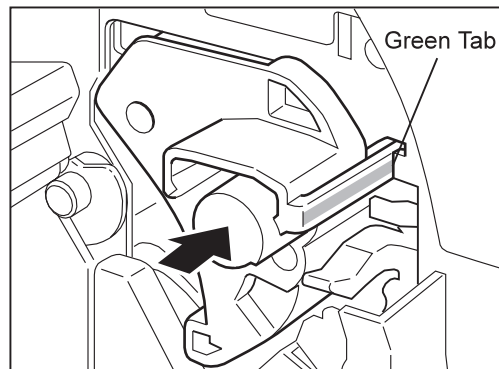

c3poa245

## Used Toner Bottle

1. Two used toner bottles were shipped with the printer. Notice the sealing cap **2**. Later, when the bottle is full, you will remove the sealing cap **2** from the storage slot and place it in the hole **1** at the top of the bottle.

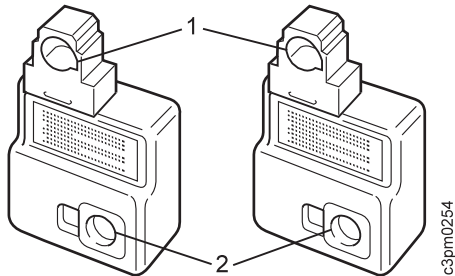

2. With the opening in the bottle facing the printer, attach the used toner bottle **1** onto the photoconductor drum cartridge. This allows the used toner to fall into the bottle.
3. Lower the photoconductor drum cover **2** to the closed position.
4. Raise the release handle **3** to the operating position.

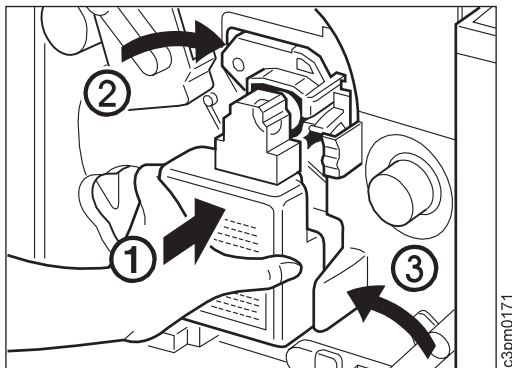

## Toner Cartridges

The IBM Network Color Printer uses four toner cartridges (cyan, magenta, yellow, and black) to produce high-quality color prints.

**Inserting Toner Cartridges:** *Do not insert the toner cartridges until you are instructed to do so.*

1. Locate the turret rotation knob and the turret color markers below:

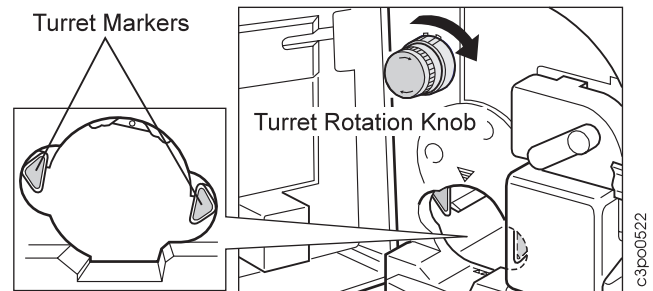

Because the printing process requires that the colors be applied in a specific order, the placement of each color toner cartridge in the turret is important. The illustration below shows the arrangement of the 4 toner cartridges relative to each other in the turret.

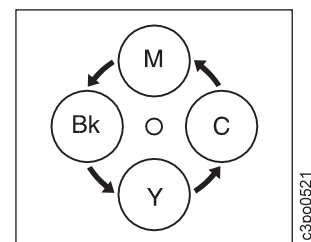

When you insert a toner cartridge, make sure that the two color markers on the toner cartridge line up with the two markers on the turret as shown.

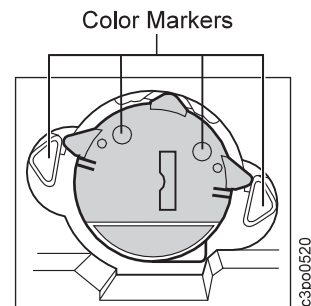



2. The turret rotation knob turns the turret so that you can insert the correct color toner cartridge. Before you insert a toner cartridge, turn the knob and notice the opening in the turret. Use the rotary knob as follows:

- a. Push the knob in **1** and turn it clockwise about the distance between arrow **1** and arrow **2**.
- b. Release the knob **2**.
- c. Turn the knob clockwise **3**. Notice the rotation of the color markers in the turret opening.
- d. When the turret is positioned to accept a cartridge, the knob moves outward **4** and locks. The color markers on the turret are fully visible.

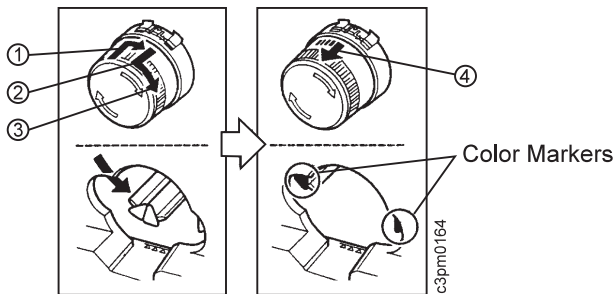

**Attention:**

When you handle a toner cartridge, do not touch the sensing window on the top and the bottom of the cartridge.

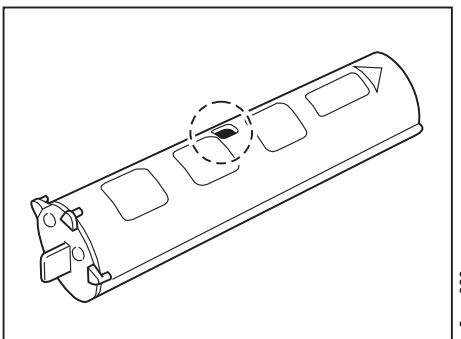

3. Remove a toner cartridge from its protective bag.
4. Hold the cartridge as shown here.

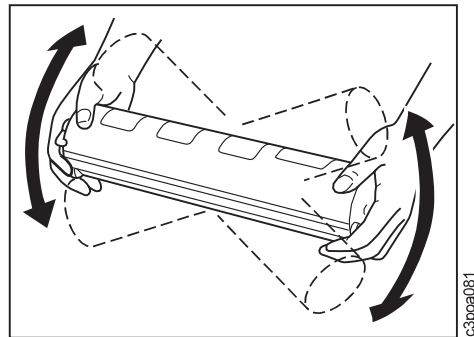

Do not hold the cartridge so tightly that the tabs on the end of the cartridge contact your hand. Pressing the tabs can partially open the cover of the developing cylinder and damage the printer.

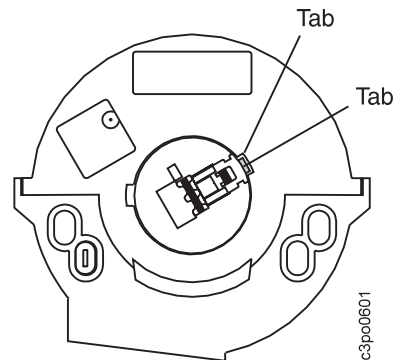

Slowly move each end up and down five or six times to distribute the toner. (Do not do this with a used or an unsealed toner cartridge.)



5. Remove the two protective tapes from the toner cartridge.

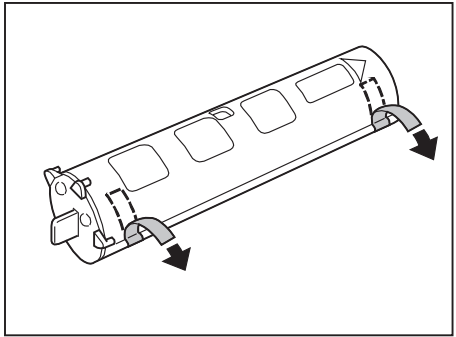

6. To remove the sealing tape, put the toner cartridge on a level surface. Hold the cartridge with one hand and slowly pull the orange tab out with the other hand. Pull the orange tab straight out to avoid breaking the tape.

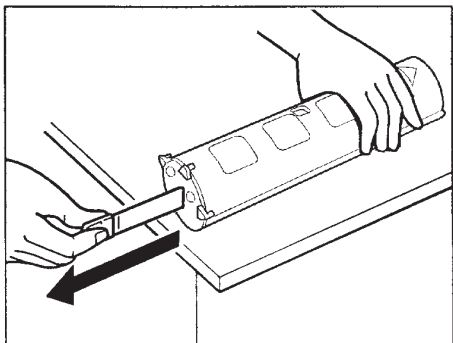
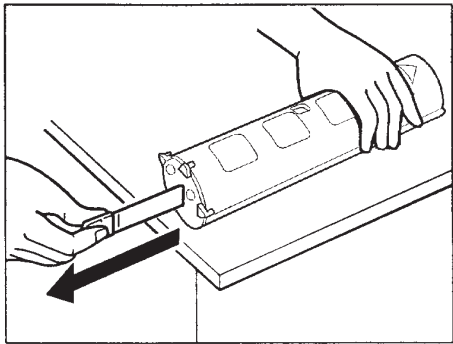

7. On one end of the toner cartridge there is an arrow **1**. On the other end, there is a notch **3** and a tab **4**. Make sure that the tab **4** is fully seated in the notch **3**.

If the tab is fully seated, go to Step 8 on page 1-14.

If the tab is not fully seated, hold the cartridge and use a pulling motion with your other hand to rotate the developing cover in the direction of the arrow 2. The tab **4** must be fully seated in the notch **3** before you install the toner cartridge.

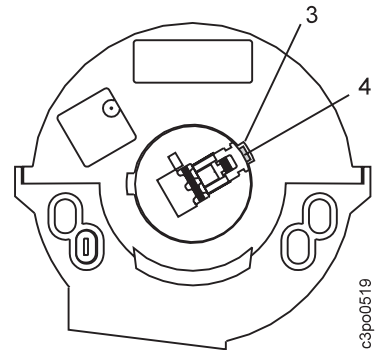
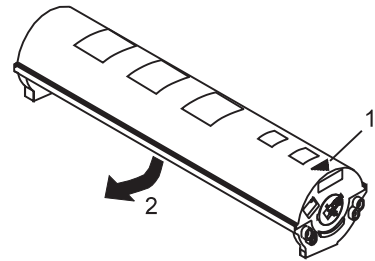

**Attention:**

Do not install a toner cartridge into the printer unless the developing cylinder cover is latched closed.

**Attention:**

Make sure that you insert only the toner cartridge that matches the color markers in the turret opening.

8. Hold the toner cartridge with the arrow **2** up and pointing toward the printer. Using the arrow **1** on the frame of the printer as a guide, slide the toner cartridge into the printer until it locks in place. You may have to push firmly on the cartridge to lock it into place.

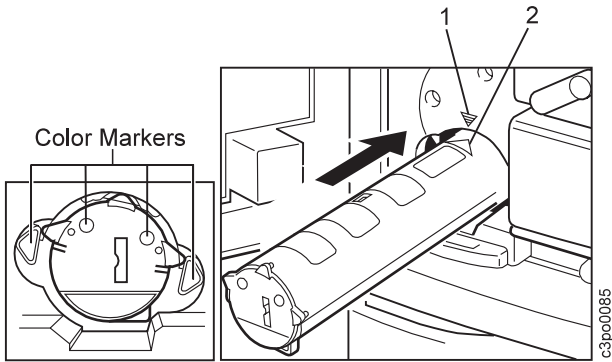

9. When the toner cartridge is locked in place, the surfaces **1** and **2** are even.

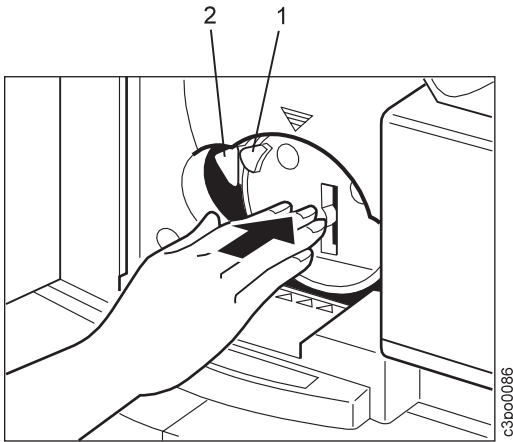

10. Repeat Step 3 on page 1-12 through Step 9 for each remaining toner cartridge.
11. After you install each of the cartridges, turn the turret rotation knob to the next cartridge to make sure that the cartridge you just installed is correctly seated.

## Fuser Oil Bottle

**Attention:**

Do not shake the fuser oil bottle. Oil can spill out.

1. Remove the foam packing block.
2. Remove the oil bottle from the package and read the oil-bottle label.
3. Remove the orange seal covering the cap.
4. Lower the oil bottle cover **1**.
5. Turn the oil bottle upside down. Hold the oil bottle with the label **2** facing out and put the bottle in the oil bottle holder.

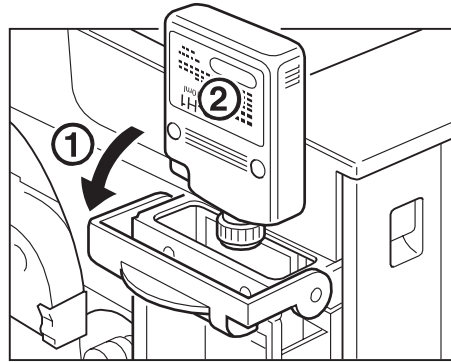

6. Align the bottle with the bottle holder. Firmly push down **1** on the bottle until it locks into place.
7. Raise the oil bottle cover **2**.

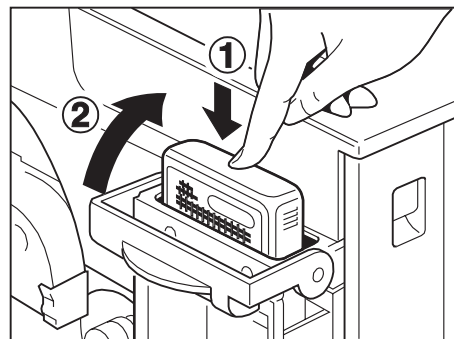

8. Close the front door.

---

## Upgrading the Controller Memory Configuration

If you are not upgrading the controller memory, go to “Connecting the Power Cords” on page 1-22.

The printer is shipped with 16MB of memory. Use this procedure to upgrade to either 32MB or 48MB. In this procedure, you will remove the controller and install the necessary single in-line memory modules (SIMMs) to match the memory configuration that you ordered. Then you will reinstall the controller.

Review all of the procedures described under the following headings before you remove the controller:

- “Electrostatic Discharge Procedures”
- “SIMM Identification and Location” on page 1-16
- “How to Remove a SIMM” on page 1-16
- “How to Install a SIMM” on page 1-16

## Electrostatic Discharge Procedures

Review the following electrostatic discharge (ESD) information. If you discharge static electricity into the circuitry of an integrated circuit, you can damage the circuit.

- Keep an ESD-sensitive part in its original shipping container, usually a protective bag, until you are ready to install it.
- Make the fewest possible movements to minimize static electricity.
- Touch the metal frame of the controller assembly to discharge static electricity in your body just before touching the ESD-sensitive part.
- Hold the ESD-sensitive part by the edges, and do not touch any components, pins, or connectors. If possible, keep one hand on the frame while you insert or remove an ESD-sensitive part.
- Do not place an ESD-sensitive part on anything that can provide a discharge path from your body through the ESD-sensitive part. If you need to put down the ESD-sensitive part, first put it into the ESD protective wrapper in which it was shipped.
- Do not let other people touch ESD-sensitive parts.
- Be careful when you work with cables that connect to logic cards or boards that are ESD-sensitive.
- Be careful when you work with ESD-sensitive parts when the humidity is low. Low humidity increases static electricity.

## SIMM Identification and Location

The following identifies the 4MB and 8MB SIMMs. You must install these SIMMs in a specific order and in specific slots on the controller circuit board.

- 4MB SIMM—There are chips on only one side of a 4MB SIMM. You may install a 4MB SIMM in any slot, J6 through J13, depending on the SIMM configuration of the controller.

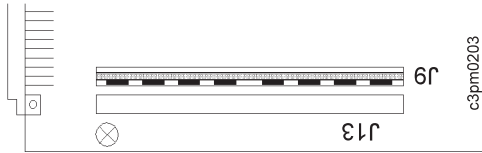

- 8MB SIMM—There are chips on both sides of an 8MB SIMM. There is also a yellow stripe near the top edge of the 8MB SIMM. You may install an 8MB SIMM only in slots J6, J7, J8, and J9.

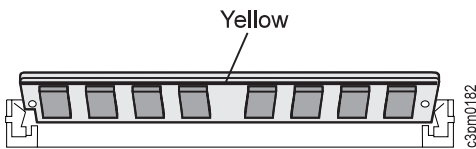
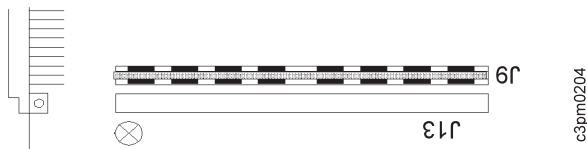

## How to Remove a SIMM

If you need to remove a SIMM, push one of the spring clips out and, while holding the SIMM, push the other spring clip out. Rotate the top of the SIMM down to a 45-degree angle, and pull the SIMM out of the slot.



## How to Install a SIMM

*Do not install the SIMMs until you are told to do so.*

When you install a SIMM, position the SIMM notch at the left end of the controller circuit board slot. Start by holding the SIMM at a 45-degree angle from the top of the board. Push the SIMM into the slot, rotate it to a vertical position, and lock it in place. Make sure that the spring clips close securely around the ends of the SIMM strip and that the SIMM strip is fully seated in the slot.

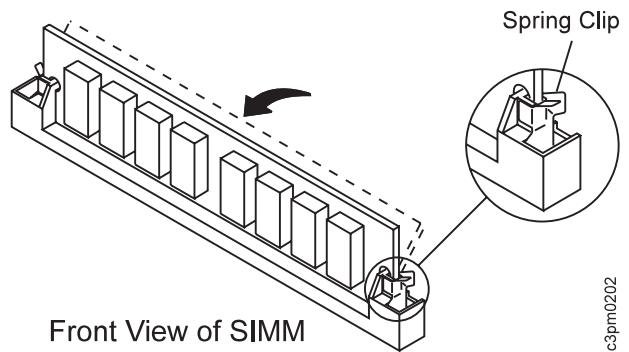
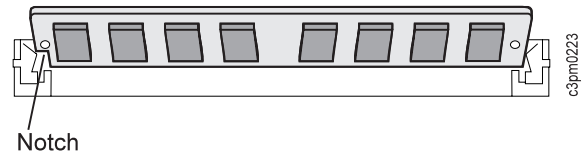

## Removing the Controller

### Attention: ESD Sensitive Area

1. Prepare a work area suitable for working on ESD-sensitive parts.
2. Loosen the 2 screws **1**. Hold the controller assembly by the metal bracket and the edges. Slide the controller assembly out of the printer and put it in the prepared work area.

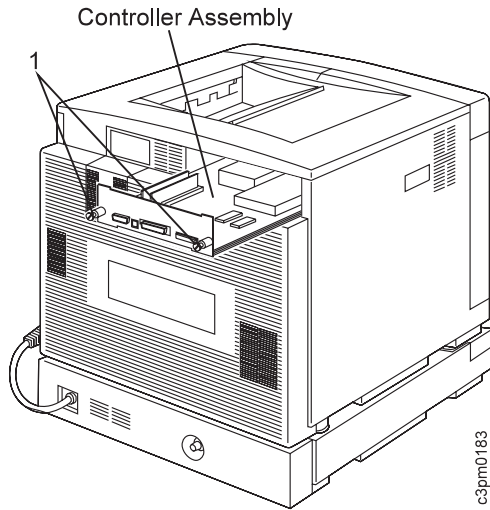

## Configuring the SIMMs

*Make sure that you configure the SIMMs correctly.*

The printer can use SIMMs in any of the following configurations:

- 16MB (default configuration)
- 32MB (optional configuration)
- 48MB (optional configuration)

See “16MB SIMM Configuration” on page 1-18 for a description and an illustration of the 16MB SIMM default configuration.

Which SIMM configuration are you installing?

- Upgrade from 16MB to 32MB, see “32MB SIMM Upgrade from 16MB Configuration” on page 1-19
- Upgrade from 16MB to 48MB, see “48MB SIMM Upgrade from 16MB Configuration” on page 1-20
- Upgrade from 32MB to 48MB, see “48MB SIMM Upgrade from 32MB Configuration” on page 1-21

Go to the appropriate SIMM installation procedure.

**16MB SIMM Configuration:** Shown below is a 16MB SIMM configuration.

**Attention: ESD Sensitive Area**

The printer is shipped with a 16MB SIMM configuration. The configuration uses four, 4MB SIMMs in 4 slots:

- A 4MB SIMM in slot J6
- A 4MB SIMM in slot J7
- A 4MB SIMM in slot J8
- A 4MB SIMM in slot J9

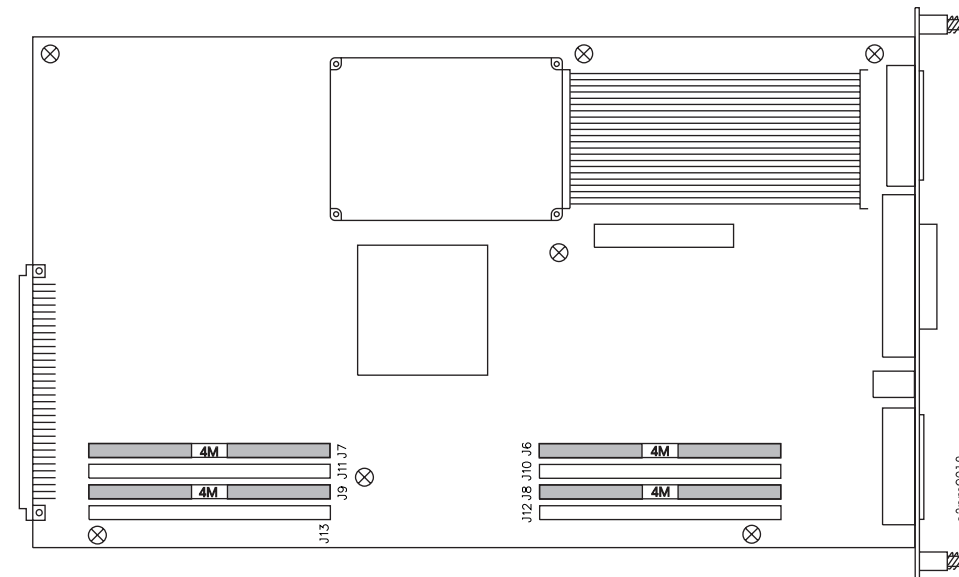

**32MB SIMM Upgrade from 16MB Configuration:** Shown below is a 32MB SIMM configuration. Notice that this configuration occupies all available SIMM slots.

*Do not install the SIMMs until you are told to do so.*

**Attention: ESD Sensitive Area**

1. Remove the 4 new 4MB SIMMs from the protective bags and put the SIMMs on the bags.
2. Remove the 4 original 4MB SIMMs from slots J6, J7, J8, and J9.
3. Install the 4 original and 4 new 4MB SIMMs *exactly* as follows:
  - A 4MB SIMM in slot J12
  - A 4MB SIMM in slot J13
  - A 4MB SIMM in slot J8
  - A 4MB SIMM in slot J9
  - A 4MB SIMM in slot J10
  - A 4MB SIMM in slot J11
  - A 4MB SIMM in slot J6
  - A 4MB SIMM in slot J7

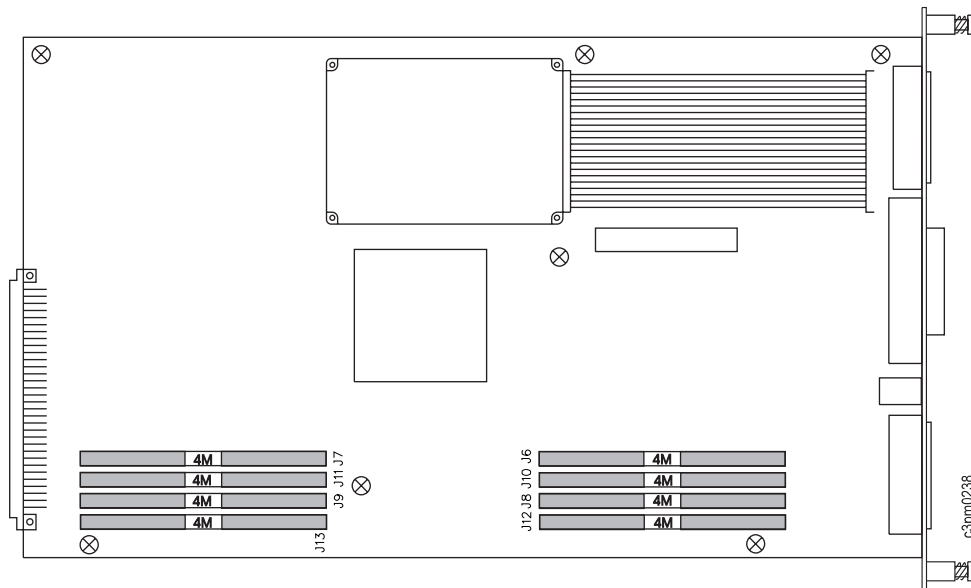

**48MB SIMM Upgrade from 16MB Configuration:** Shown below is a 48MB SIMM configuration. Notice that this configuration occupies all available SIMM slots.

*Do not install the SIMMs until you are told to do so.*

**Attention: ESD Sensitive Area**

1. Remove the 4 new 8MB SIMMs from the protective bags, and put the SIMMs on the bags.
2. Remove the 4 original 4MB SIMMs from slots J6, J7, J8, and J9.
3. Install 2 original 4MB SIMMs as follows:
  - A 4MB SIMM in slot J12
  - A 4MB SIMM in slot J13
4. Install 2 new 8MB SIMMs as follows:
  - An 8MB SIMM in slot J8
  - An 8MB SIMM in slot J9
5. Install 2 original 4MB SIMMs as follows:
  - A 4MB SIMM in slot J10
  - A 4MB SIMM in slot J11
6. Install 2 new 8MB SIMMs as follows:
  - An 8MB SIMM in slot J6
  - An 8MB SIMM in slot J7

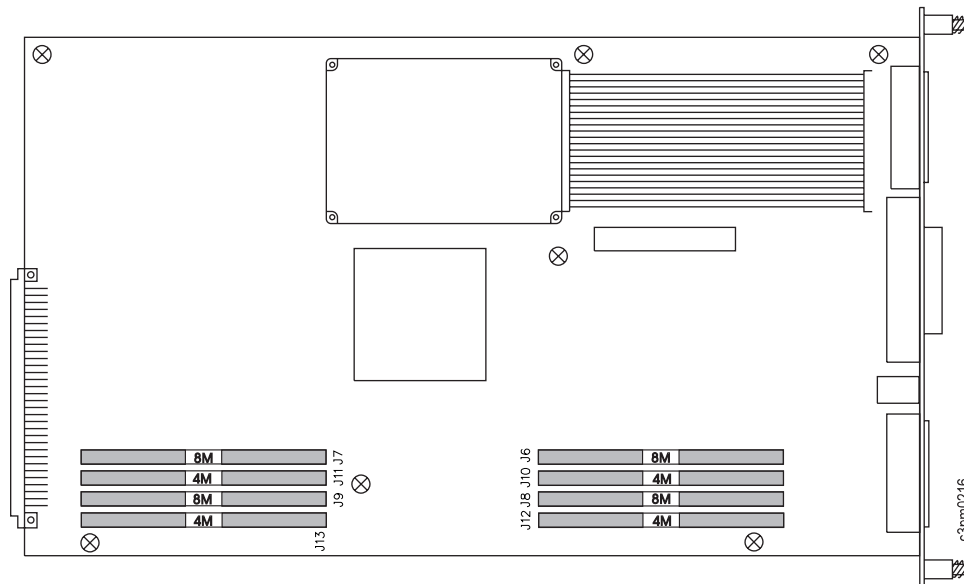



**48MB SIMM Upgrade from 32MB Configuration:** Shown below is a 48MB SIMM configuration. Notice that this configuration occupies all available SIMM slots.

*Do not install the SIMMs until you are told to do so.*

**Attention: ESD Sensitive Area**

1. Remove the 4 new 8MB SIMMs from the protective bags, and put the SIMMs on the bags.
2. Remove the original 4MB SIMMs from slots J6, J7, J10, J11, J8, and J9.
3. Install 2 new 8MB SIMMs as follows:
  - An 8MB SIMM in slot J8
  - An 8MB SIMM in slot J9
4. Install 2 original 4MB SIMMs as follows:
  - A 4MB SIMM in slot J10
  - A 4MB SIMM in slot J11
5. Install 2 new 8MB SIMMs as follows:
  - An 8MB SIMM in slot J6
  - An 8MB SIMM in slot J7
6. Place the 4 remaining 4MB SIMMs in the protective bags and store them in a safe place.

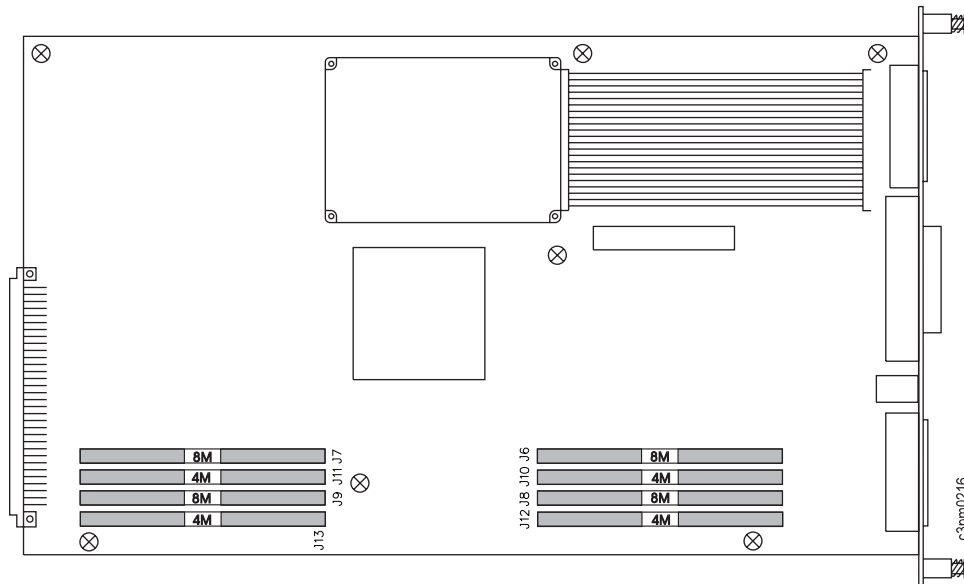

## Reinstalling the Controller

When you finish installing the correct SIMM configuration on the controller PCB, you can install the controller assembly into the printer.

### Attention: ESD Sensitive Area

1. Hold the controller assembly by the metal bracket and the edges of the controller assembly. Place the assembly between the centers of the blue rails and gently guide it into the printer. If you feel any resistance, gently move the assembly up and down to find the center of the rails again. Guide the assembly in until the metal bracket is flush with the outside of the printer.
2. Position the thumbscrews **1** in the holes and hand-tighten them.

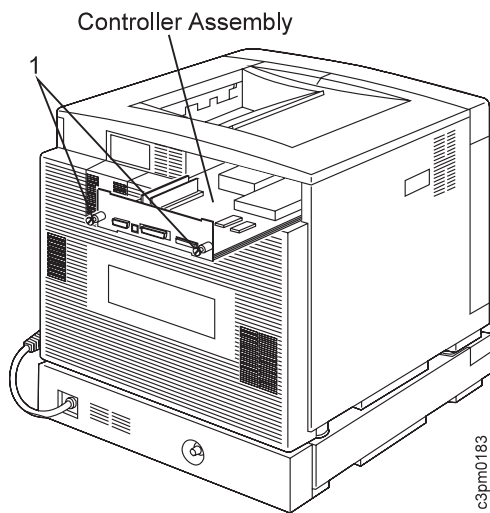

3. Do not connect any network or system cables to the controller until you are instructed to do so.

## Connecting the Power Cords

### Attention:

Connect all attachment and interface cables before you connect the power cord to a power source. Likewise, unplug the power cord from the power source before you remove all attachment and interface cables.

In this procedure, you will load paper into the tray(s), connect the power cord, and switch on the printer.

1. Load the paper tray(s) with the high-quality, laser color copy paper provided. If necessary, refer to *IBM Network Color Printer: Operator's Guide*.
2. Make sure that the printer is switched off.

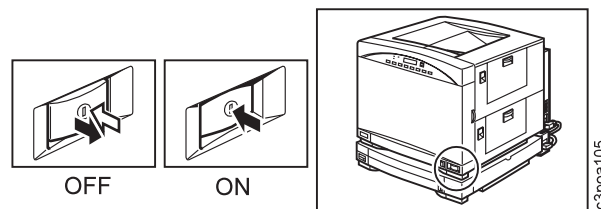

3. Make sure that all doors and covers are closed.
4. Attach the interface cables to the printer. Each port is labeled. Attach the parallel cable to the parallel port and the Ethernet cable to the Ethernet port. Remember, you cannot have two Ethernet cables attached at the same time.

- If you installed the optional tray 2 paper feeder, plug the power cord that is connected to the paper feeder into the power receptacle on the right side of the printer. Then, plug the supplied power cord into the power receptacle on the right side of the paper feeder assembly, just below the printer power receptacle.

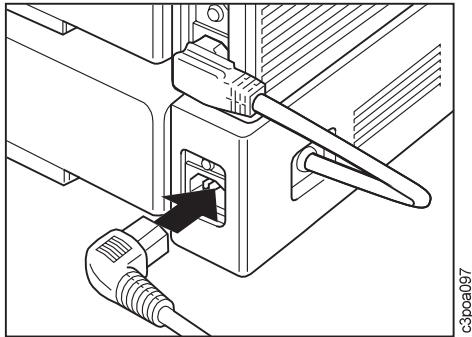

c3poa097

- If you did not install the optional tray 2 paper feeder, plug the supplied power cord into the power receptacle on the right side of the printer.
- Plug the power cord into the wall receptacle.
- Switch on printer power.

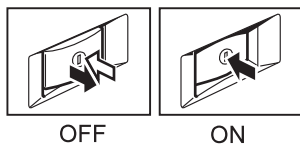

OFF

ON

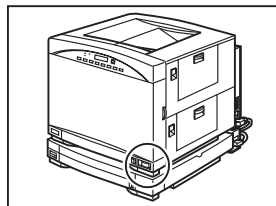

c3poa105

The printer fuser takes approximately 5 minutes to warm up if it is cold when you switch on the printer. While the printer is warming up, it runs a power-on self-test (POST). The POST checks to see if the printer is working correctly.

As the POST runs, you see status messages on the display panel. You do not have to read these messages unless the POST stops before the test is finished. Normally, the POST finishes without problems and you see the READY message on the display panel.

If the POST does stop before it is finished, the Attention light on the display panel flashes. Check the display panel for a message, an error code, or a blank display. Refer to Understanding Operator Messages in *IBM Network Color Printer: Operator's Guide*.

Normally, the POST completes uneventfully and the printer displays READY.

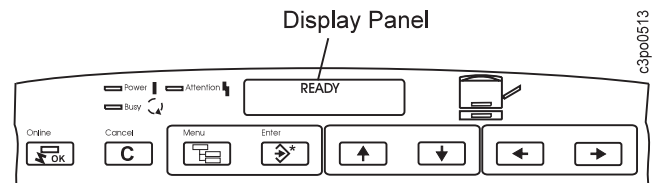

c3poa0513

- The IBM Network Color Printer will print a full-color printout and deliver it to the top output tray. If this does not happen or if the print quality is poor, check the display for a message, an error code, or a blank display. If the problem is print quality, see "Correcting Print Quality Problems" in *IBM Network Color Printer: Operator's Guide*.

---

## Printing a Test Page

Use the following procedure to print a TEST PAGE. The TEST PAGE shows you samples of color and grayscale that you can use to determine whether or not the printer is correctly printing from an application. The TEST PAGE also shows you the printer name, printer model, color mode, print count, calibration, memory multiplier setting, color-rendering dictionary, and date and time printed.

1. Make sure the Online light is lit. Press the Menu push button. You see PRINT PAGES on the first line of the display menu.
2. Use the Menu Scrolling push buttons (↑ and ↓) to scroll through the PRINT PAGES menu until you see TEST PAGE on the second line of the display panel.
3. Press Enter. Several messages appear on the display panel that tell you what the printer is doing. When the TEST PAGE finishes printing, READY displays. Keep this TEST PAGE in a safe place away from light so you can use it for comparisons at a later time.

---

## Printer Configuration

You are ready to configure the printer for your network or operating environment. For instructions on this, refer to *IBM Network Color Printer: Administrator's Guide*.

## Chapter 2. Relocation

### Attention:

Do not relocate or store the printer without first removing the fuser oil.

The following procedures guide you through preparing the printer for relocation.

### Preparation

Contact your authorized dealer to obtain a relocation kit for the Network Color Printer. The IBM part number for the kit is 63H3881. The relocation kit does not contain shipping materials for either the optional printer stand or the optional tray 2 paper feeder.

The relocation kit (63H3881) contains the following items:

#### Part Number Item

6038888	Pallet (1)
7323979	Shipping-box side panels (2)
7323980	Shipping box top and bottom (2)
7324408	Foam corner-packing inserts (8)
7324409	Spare parts box (1)
63H3882	Oil removal tool (1)
63H3883	Recycle oil bottle (1)
63H3884	Orange fuser-spacers (2)
63H3885	Transfer drum lock screw (1)
7323760	Plastic bag for printer (1)
390105153	Bags for toner cartridges (4)
390105810	Bag for fuser (1)
390105153	Bag for photoconductor drum cartridge (1)
7351839	Bubble wrap, 30×60 cm (12×24 in.) (5)
74F5698	Tape, 5 cm (2 in.) with IBM logo (1)
479904501	Banding strap, 1.3 cm×9 m (½ in.×10 yd)
479904502	Buckle for banding strap (2)

Have the following items available before beginning the procedure:

- Flat-blade screwdriver
- Orange photoconductor-drum cartridge protective shield
- Absorbent towels

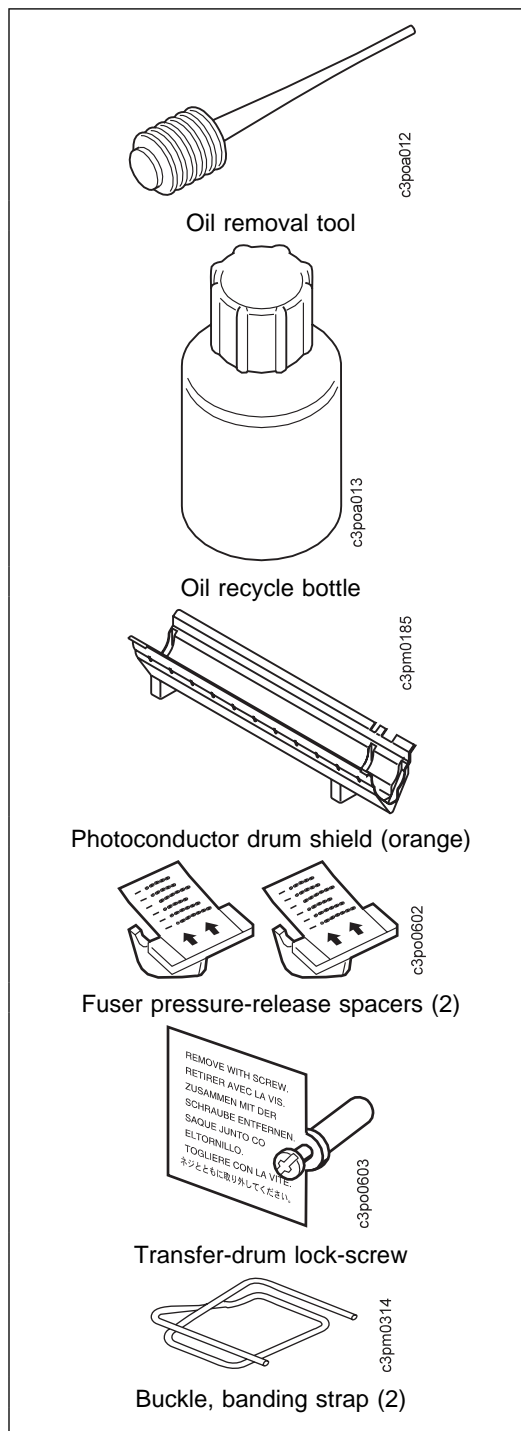

## Disposing of Materials

<2-9> CAUTION:

This printer may contain materials, either components or supplies, that are meant to be discarded. Dispose of all items according to local regulations.

## Turning Off the Printer

<2-1> CAUTION:

Switch off printer power and unplug the power cord from the power receptacle.

This allows time for the parts in the fuser to cool before you handle them.

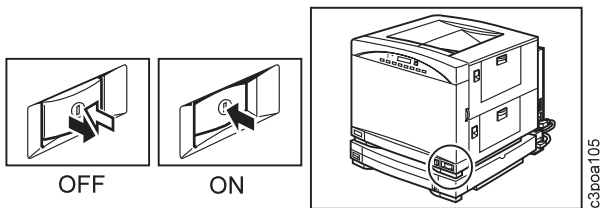

## Disconnecting the Power Cord

1. Unplug the power cord from the wall receptacle.
2. If you did not install the optional tray 2 paper feeder, unplug the power cord from the power receptacle on the right side of the printer. Save the power cord for packing.

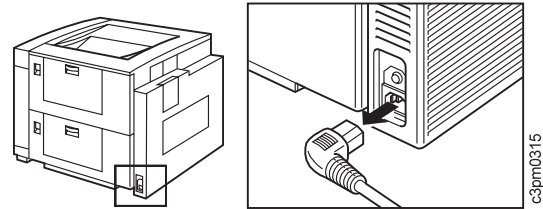

3. If you installed the optional tray 2 paper feeder, perform the following:
  - a. Unplug the power cord from the power receptacle of the paper feeder assembly. Save the power cord for packing.

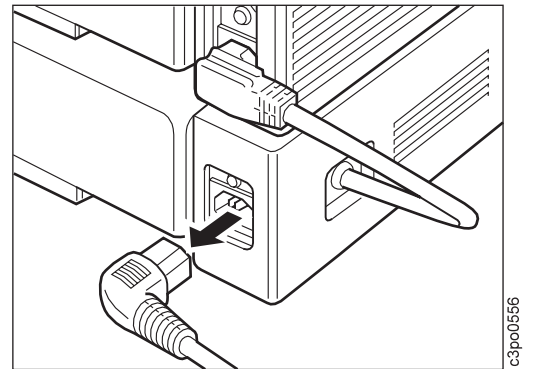

- b. Unplug the tray 2 paper feeder power cord from the power receptacle on the right side of the printer.

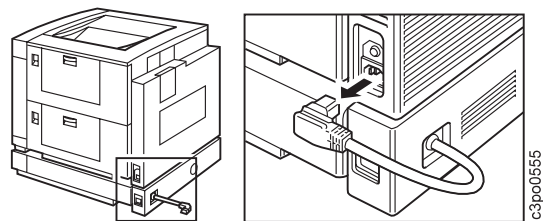

---

## Removing Paper

1. Remove any paper from the auxiliary tray, and then close the tray.

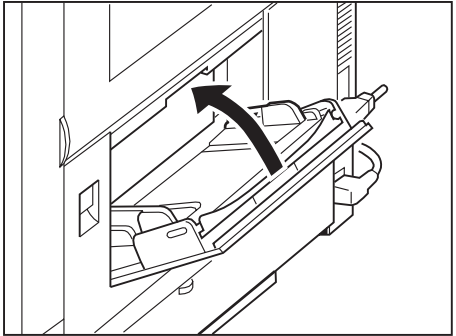

2. Close the side output tray.

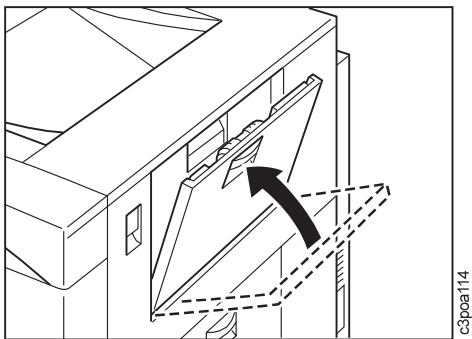
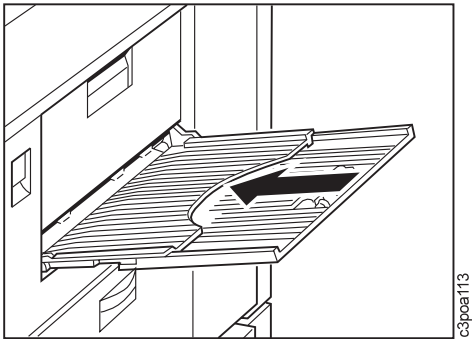

3. Remove any paper from tray 1.

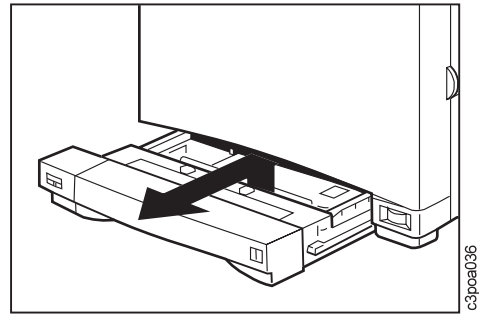

4. If the optional tray 2 paper feeder is installed, remove any paper from it.
5. If you installed the printer stand, remove any supplies or materials stored in the stand.

## Removing the Four Toner Cartridges

**Attention:** Be careful when you handle toner cartridges. The used toner cartridges have no seal so some toner may spill.

1. Open the front door.

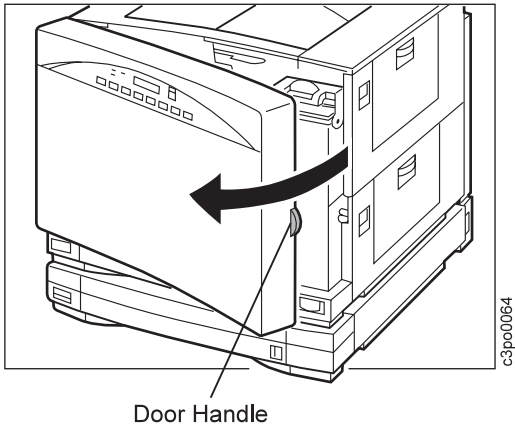

2. Find the turret rotation knob.

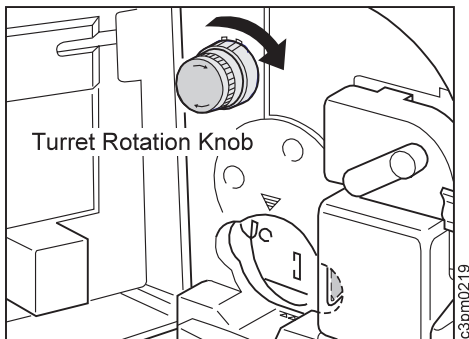

3. Use the turret rotation knob as follows:
  - a. Push the knob in **1** and turn it clockwise about the distance between arrow **1** and arrow **2**.
  - b. Release the knob **2**.
  - c. Turn the knob clockwise **3**. Notice the rotation of the color markers in the turret opening.
  - d. When the turret is positioned to accept a cartridge, the knob moves outward **4** and locks.

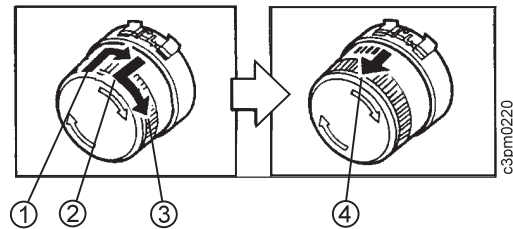

4. Make sure that the turret rotation knob is locked and that the color markers are fully visible. Pull the eject handle to release the toner cartridge.

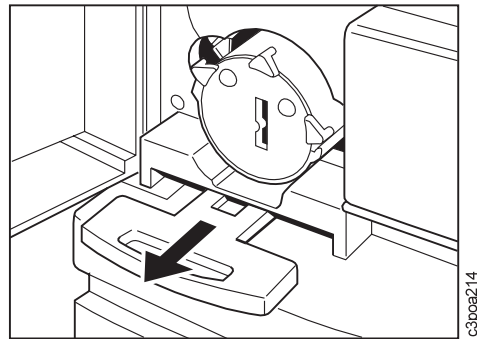

5. Slide the cartridge out.

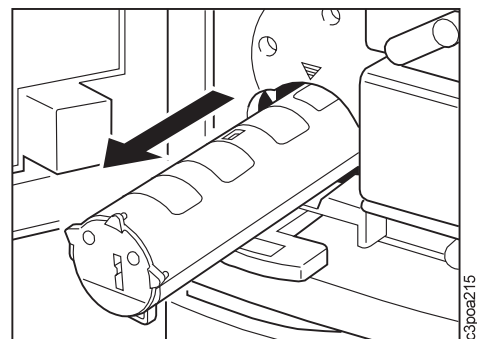



6. Remove any excess toner from the outside of the toner cartridge.
7. Tape the cartridge closed and put it aside.

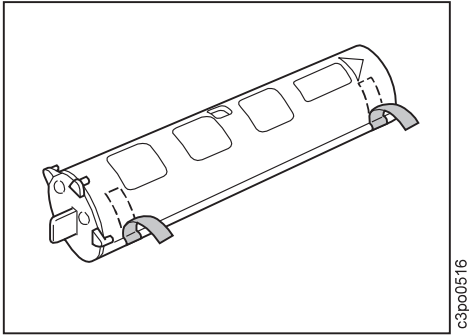

c3po0516

8. Repeat Step 3 on page 2-4 through Step 7 for each of the remaining toner cartridges.

## Removing the Photoconductor Drum Cartridge

In this procedure, you will remove the used toner bottle and seal it, and remove the photoconductor drum cartridge.

1. Push down on the release handle.

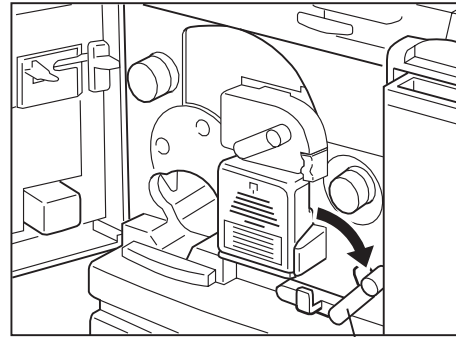

c3po0560

Release Handle

2. Open the photoconductor drum cover.

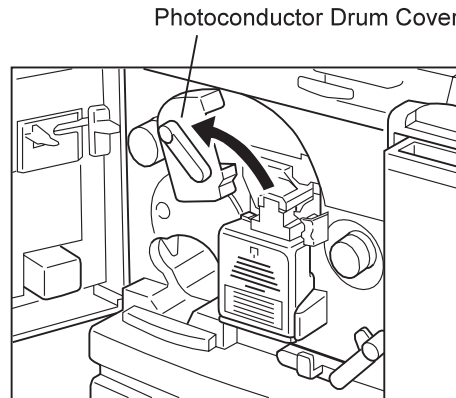

Photoconductor Drum Cover

c3po0561

3. Remove the used toner bottle.

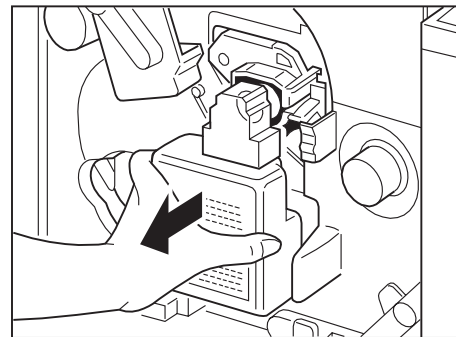

c3poa236

4. Seal the used toner bottle and put it aside.

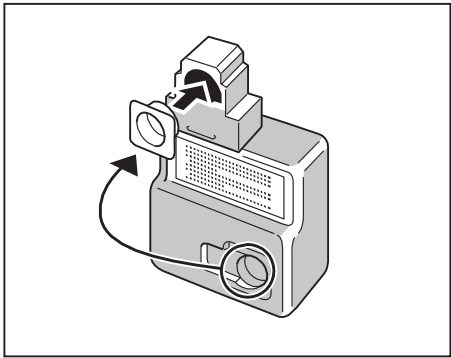

c3poa237

**Attention:** Do not remove the photoconductor drum cartridge without using the orange photoconductor drum shield. You may damage the drum if you do not use the shield. Do not expose the drum to strong light.

5. Place the V-shaped end of the orange photoconductor drum shield in the V-shaped support.
6. Press the green tab **1** on the right side of the photoconductor drum cartridge, and pull the drum cartridge out **2** of the printer onto the shield. Put the photoconductor drum aside, and protect it from excessive light.

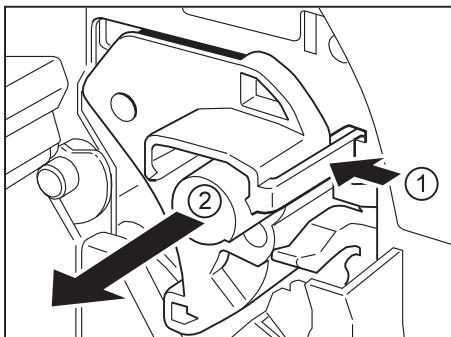

c3po0238

7. Lower the photoconductor drum cover to the closed position.

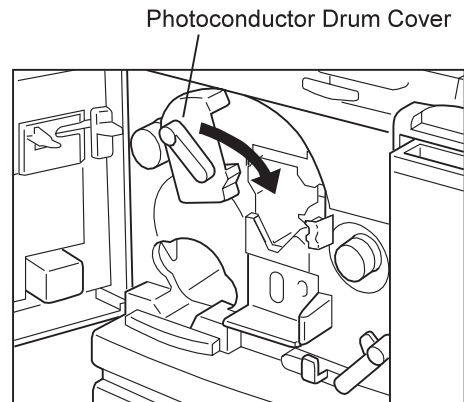

Photoconductor Drum Cover

c3po0618

8. Raise the release handle to the operating position.

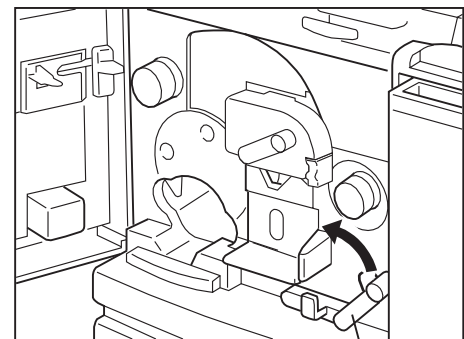

Release Handle

c3po0619

## Removing the Fuser Oil

### Preparing the Work Area

1. Choose a level work area on which to put the fuser oil. Put absorbent towels under the front of the printer and on the work area in case a few drops of fuser oil spill. Keep towels available in case you need to clean your tools.
2. Make sure that the printer is stable. If the printer is on the printer stand, make sure that the casters underneath the stand are locked.

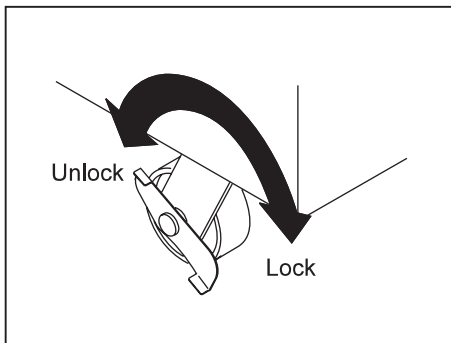

### Removing the Oil

<2-6> CAUTION:

High temperature. Allow parts in this area to cool for at least 30 minutes before handling them.

1. Open the lower access door.
2. Open the fuser access door on the upper right side of the printer.

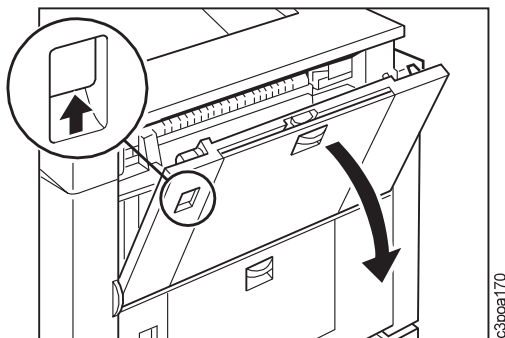

3. Secure the fuser using the two orange spacers supplied in the relocation kit. Slip the hooked end of each spacer under the fuser exit roll assembly mounting shaft. Press down and pivot the spacer to lock it in place.

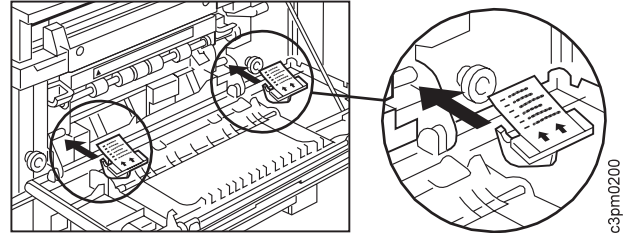

4. Release the fuser access door-strap as follows:

- a. Slide the upper locking tab down **1**.
- b. Pull the tab out from the printer frame **2**, then lift the tab up and out **3**.

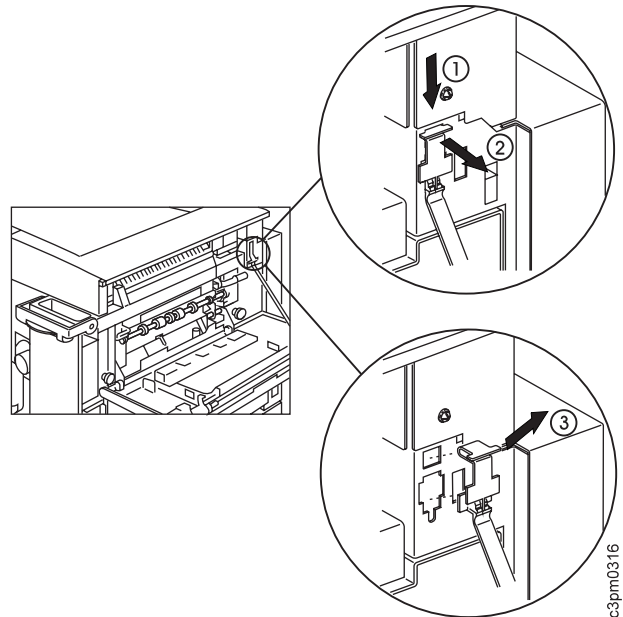

5. Slide the fuser access door to the left and then rotate it down until the tab on the right pivot aligns with the cutout in the right bracket.
  1. Slide the door to the left again and out of the brackets.

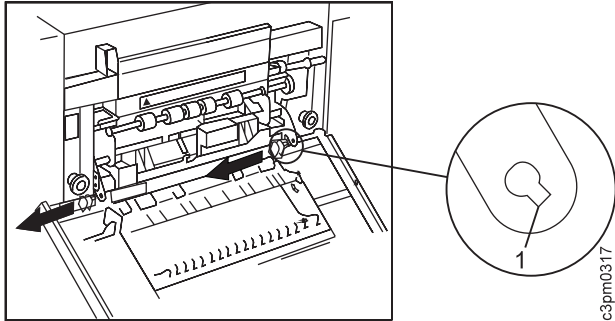

c3pm0317

6. Set the fuser access door aside for packaging.

**<2-4> CAUTION:**

**If spilled, fuser oil causes hazardous surfaces. Prevent anyone from entering the area until the surface is clean.**

7. Lower the fuser oil bottle cover **1**. Lift the oil bottle **2** from the oil bottle holder and put a towel under the bottle to prevent drops of oil from spilling on the floor.

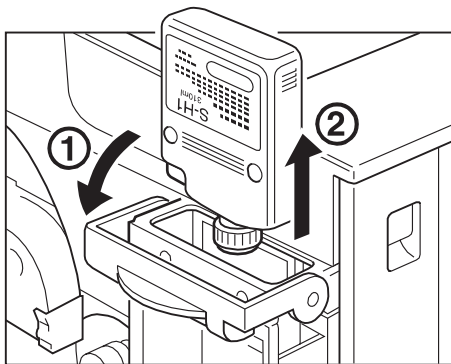

c3pea227

**Attention:**

Do not put the fuser oil bottle or the oil recycle bottle on top of the printer while recycling oil.

8. Wipe off any excess oil on the bottle and put the bottle upright in a safe place in the work area.

9. Open the oil recycle bottle and remove the inner seal.

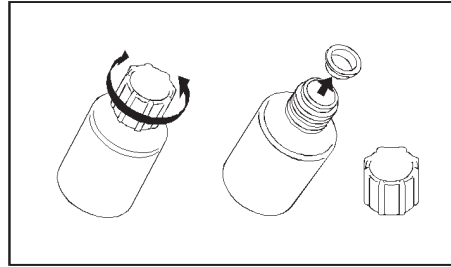

c3po0502

10. Put the oil recycle bottle on a towel on a level surface near the printer.

11. Use the oil removal tool to remove the fuser oil from the oil bottle holder as follows:

- a. Push the top of the oil removal tool all the way down. Insert the pointed end of the oil removal tool into the oil supply in the oil bottle holder. Release the pressure on the oil removal tool and allow the oil to flow into it.

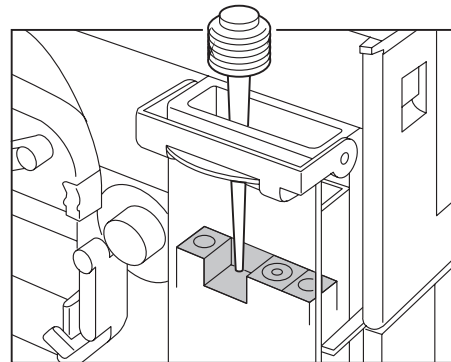

c3poaad5

- b. Be careful not to spill any oil. Take the oil removal tool out of the oil bottle holder and insert the pointed end of the tool into the oil recycle bottle. Push the top of the tool down and force the oil into the recycle bottle.

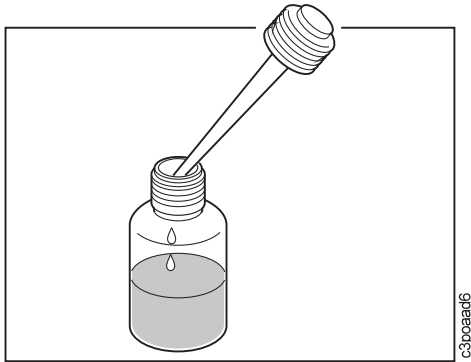

12. Repeat Step 11a on page 2-8 and Step 11b until you have removed most of the oil from the oil bottle holder.

**<2-10> CAUTION:**  
Pinch hazards and sharp edges are in this area. Be careful.

13. Use the green fuser jam release lever to pump the remaining oil from the fuser into the oil bottle holder. You will need to pump the lever approximately 50 times.

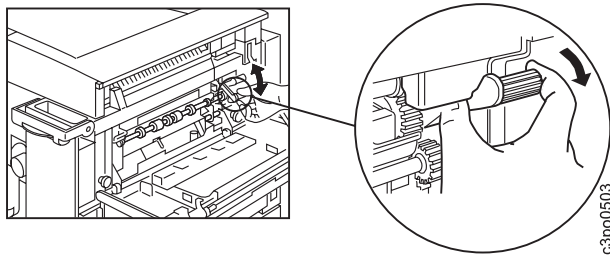

14. Repeat Step 11 on page 2-8 and Step 13, 3 or 4 times until you have removed most of the oil from the fuser.

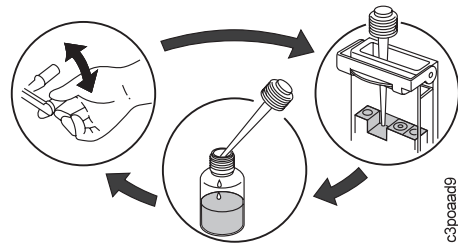

15. Replace the inner seal on the oil recycle bottle and cap the bottle.

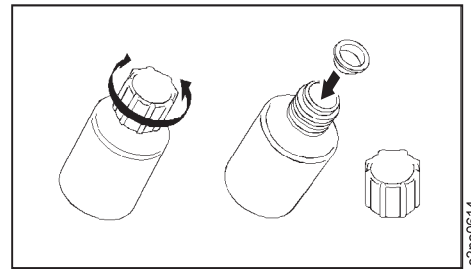

16. Clean the oil removal tool with a towel and store it in the box in which it was shipped.

17. Loosen the 2 screws, pull the fuser assembly by the handles toward you, and lift the fuser straight up and out.

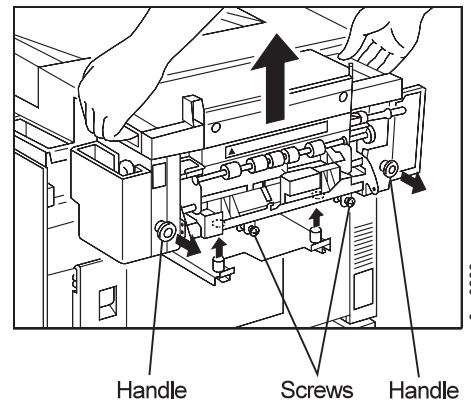

18. Set the fuser aside for packing.

19. Push the fuser slides back into the printer.

20. Close the lower access door.

## Taping the Printer

1. Make sure that the release handle is in the up position.
2. Insert the transfer drum locking screw (supplied in the relocation kit) into the hole, push the screw down, and tighten it.

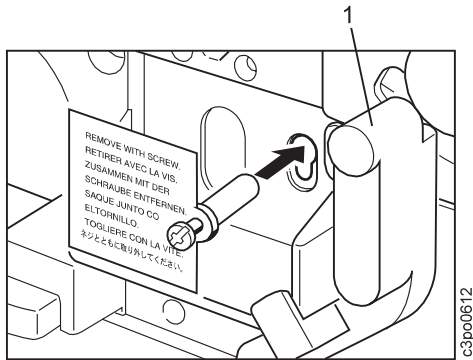

3. Raise and tape the fuser oil bottle cover.

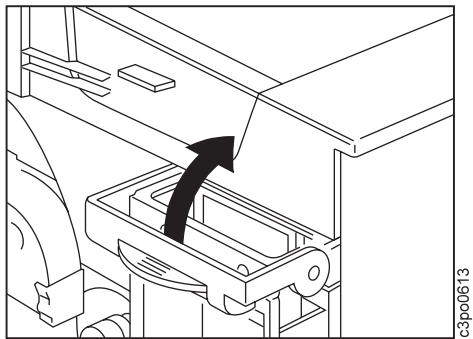

4. Tape the photoconductor drum cover **1** down. Tape the release handle **2** in the up position.

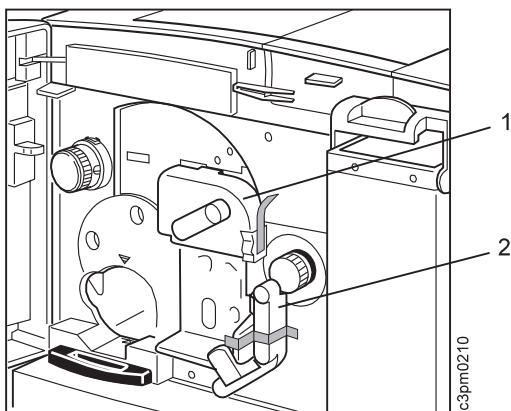

5. Close the front door.
6. Tape the top cover and the removable air vent.

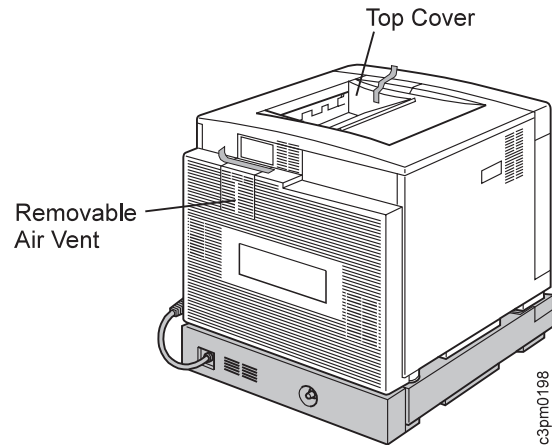

7. Tape the printer doors as shown to ensure that the fuser access door, feeder access door, front door, and side and rear covers are secured.

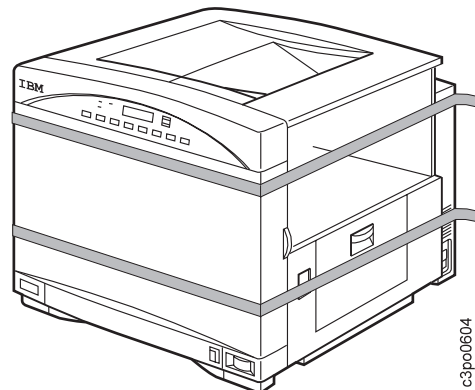

## Removing the Printer

### <2-7> CAUTION:

The printer weighs approximately 50 kg (110 lb). You need at least two people to move the printer.

1. Before moving the printer, note the following:
  - When you grip the printer, use only the recessed gripping slots **1**, **2**, **3**, and **4** as shown in the illustration in Step 2. Locate these slots.
  - Plan how you will move and place the printer.
2. If the printer is on top of the optional tray 2 paper feeder, remove the two locking pins and put them aside.

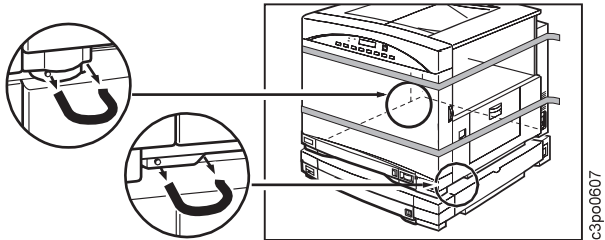

3. Carefully remove the printer from the optional tray 2 paper feeder, the optional printer stand, or the table.

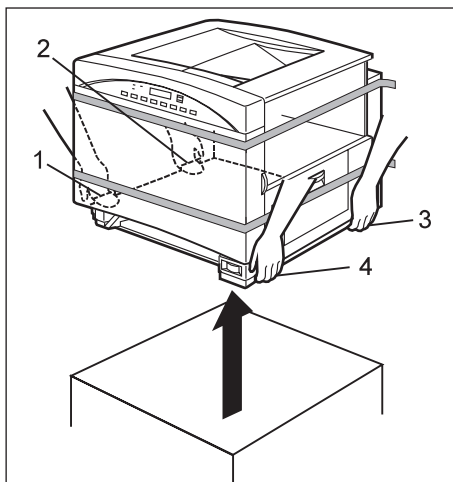

## Removing the Optional Tray 2 Paper Feeder

1. If the optional printer stand is installed, remove tray 2.

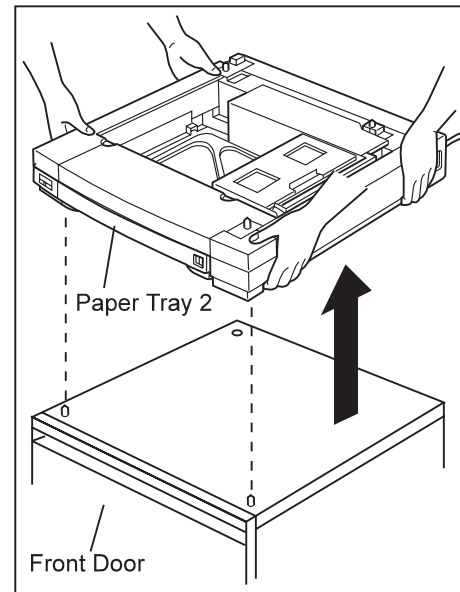

## Taping the Optional Paper Stand

1. Make sure that the stand is empty.
2. Raise the leveling pads all the way.
3. Tape the door closed.

## Packing the Printer

Pack the printer and as follows:

1. Remove the side panels from the bottom section of the shipping box.
2. Place the bottom section of the shipping box on the pallet.
3. Place 2 foam corner-packing inserts into the bottom of the shipping box as shown.

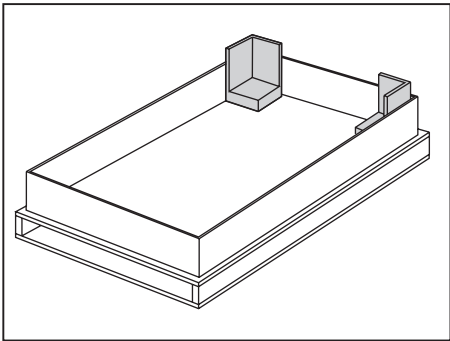

c3pm0309

### <2-7> CAUTION:

**The printer weighs approximately 50 kg (110 lb). You need at least two people to move the printer.**

4. Before moving the printer, note the following:

When you grip the printer, use only the recessed gripping slots **1**, **2**, **3**, and **4** as shown in the illustration below. Locate these gripping slots.

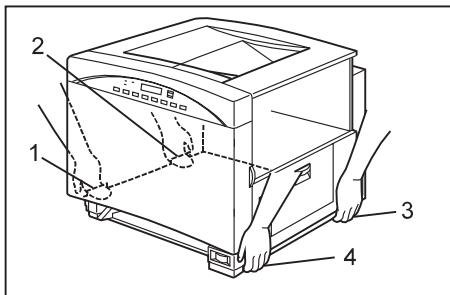

c3po0615

5. Plan how you will move and place the printer in the shipping box. Notice that the *back of the printer faces the center of the box*.
6. Carefully place the printer in the shipping box with the bottom, front corners of the printer resting on the 2 foam corner-packing inserts.
7. Place the large plastic bag over the printer.
8. Raise the back of the printer and place a foam corner-packing insert under each rear corner of the printer.

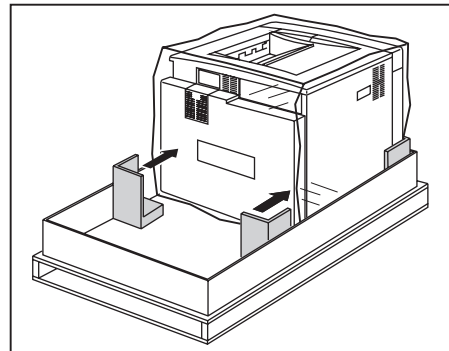

c3pm0310

9. Ensure that the foam corner-packing inserts are tight against the printer, and that there is enough space to insert the shipping-box side panels between the inserts and the shipping box.
10. Fit the 2 shipping-box side panels into the bottom section of the shipping box.

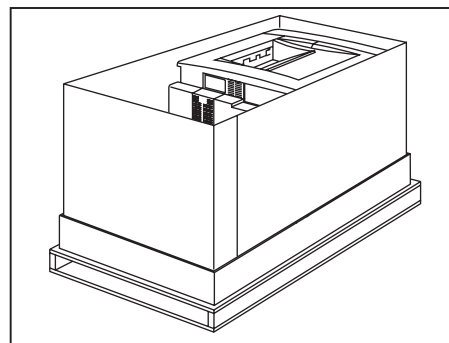

c3pm0319



11. Place a foam corner-packing insert at each top corner of the printer and tape each insert in place.

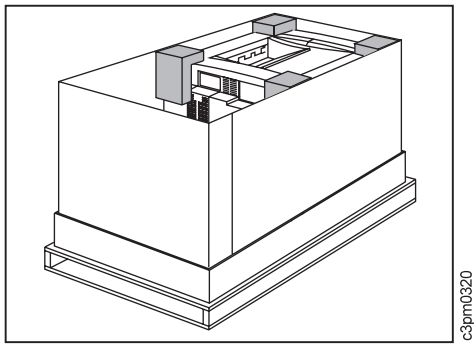

12. Insert each of the following items into a plastic bag, and pack them in the smaller shipping box:

- Fuser
- Photoconductor drum cartridge
- 4 toner cartridges (each in a separate bag)

13. Ensure that the fuser oil bottle, the oil removal tool, and the oil recycle bottle are clean, and then place them into the smaller box.

14. Wrap the fuser access door in 1 sheet of bubble wrap, and put it and the power cord into the smaller shipping box.

15. Tape the smaller box closed with the 5 cm (2 in.) IBM logo tape. Put the smaller shipping box into the larger box as shown:

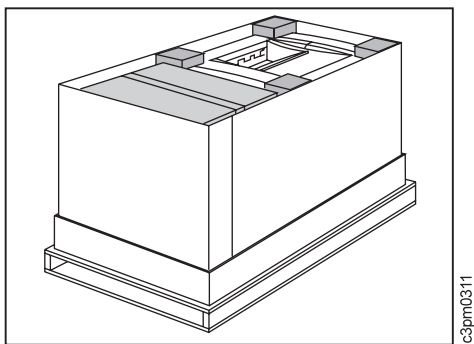

16. Put the remaining 2 sheets of bubble wrap around the smaller shipping box to hold it in place.

17. Place the top on the shipping box and, using the cloth banding strap, band the box to the pallet as follows:

- a. Cut the banding strap into 2 equal lengths.
- b. Route the banding strap through the pallet and around the shipping box, attaching the shipping box to the pallet.
- c. Thread the banding strap through the buckle as shown, and then pull in the direction of the larger arrows to tighten the banding strap. If you cut the ends of the banding strap, leave at least 2.5 cm (1 in.) of banding strap protruding from each side of the buckle.
- d. Repeat Steps 17a, 17b, and 17c for the second strap.

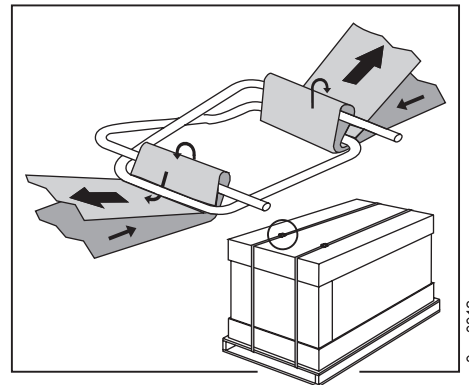

18. Contact your authorized dealer if you have any problems packing the printer or questions about shipping.



---

# Readers' Comments — We'd Like to Hear from You

**IBM Network Color Printer  
Installation and Relocation**

**Publication No. G544-5362-02**

Use this form to provide comments about this publication, its organization, or subject matter. Understand that IBM may use the information any way it believes appropriate, without incurring any obligation to you. Your comments will be sent to the author's department for the appropriate action. Comments may be written in your language.

**Note:** IBM publications are not stocked at the location to which this form is addressed. Direct requests for publications or for assistance in using your IBM system, to your IBM representative or local IBM branch office.

	Yes	No
• Does the publication meet your needs?	_____	_____
• Did you find the information:		
Accurate?	_____	_____
Easy to read and understand?	_____	_____
Easy to retrieve?	_____	_____
Organized for convenient use?	_____	_____
Legible?	_____	_____
Complete?	_____	_____
Well illustrated?	_____	_____
Written for your technical level?	_____	_____
• Do you use this publication:		
As an introduction to the subject?	_____	_____
As a reference manual?	_____	_____
As an instructor in class?	_____	_____
As a student in class?	_____	_____
• What is your occupation?	_____	_____

---

Thank you for your input and cooperation.

**Note:** You may either send your comments by fax to 1-800-524-1519, or mail your comments. If mailed in the U.S.A., no postage stamp is necessary. For residents outside the U.S.A., your local IBM office or representative will forward your comments.

**Comments:**

---

Name

---

Address

---

Company or Organization

---

Phone No.



Cut or Fold  
Along Line

Fold and Tape

Please do not staple

Fold and Tape



NO POSTAGE  
NECESSARY  
IF MAILED IN THE  
UNITED STATES

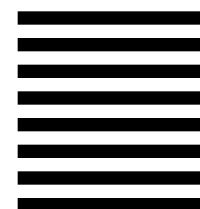

# BUSINESS REPLY MAIL

FIRST-CLASS MAIL PERMIT NO. 40 ARMONK, NEW YORK

POSTAGE WILL BE PAID BY ADDRESSEE

Information Development  
The IBM Printing Systems Company  
Department H7FE Building 003G  
P O Box 1900  
BOULDER CO 80301-9817



Fold and Tape

Please do not staple

Fold and Tape

Cut or Fold  
Along Line