第7章 配線図

この章では、IBM 5577-V02 シリアル・プリンターにおける各機能別コネクタの接続図と、各コネクタのピン配列を表示している。なお、各図中のピン番号は、カード上、または取り付けブラケット等に固定されたコネクタを見たときの状態を示してゐる。



図 7-1. IBM5577-V02 の Block Diagram



図 7-2. Logic Card のコネクター配置図

ピン番号	信号名
1	Carrier Motor+
2	Carrier Motor-

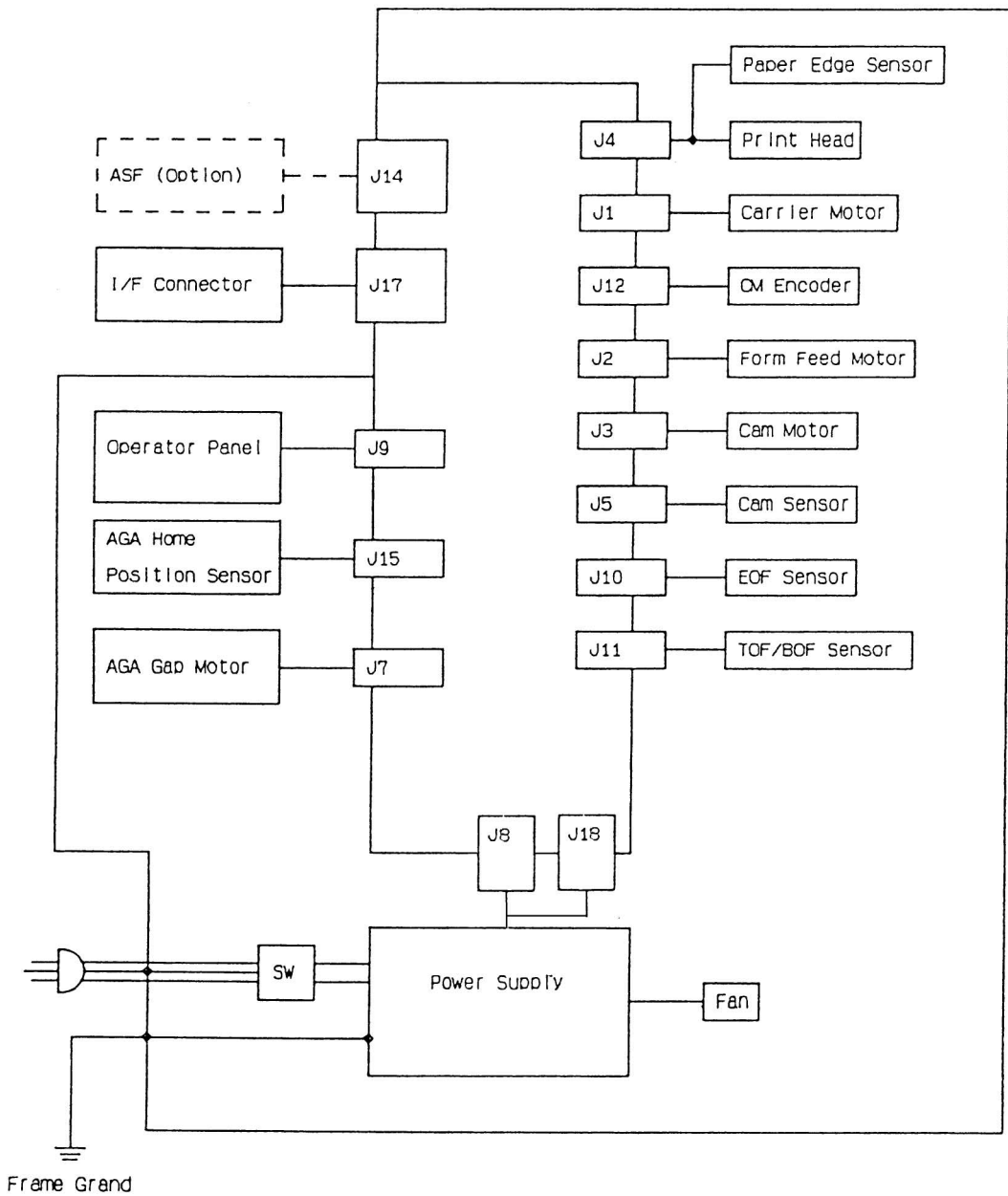
図 7-3. コネクターJ1 (Carrier Motor)

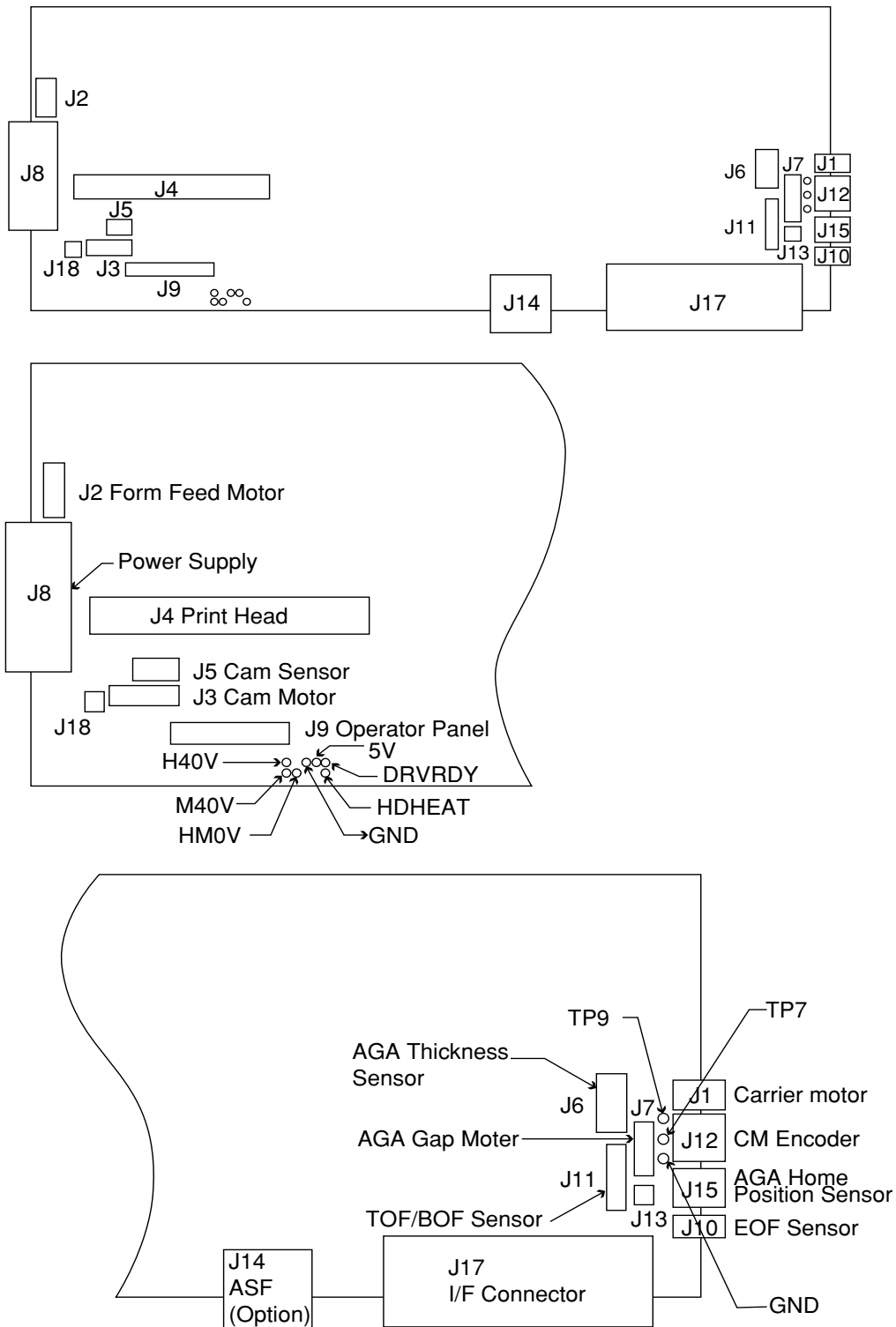
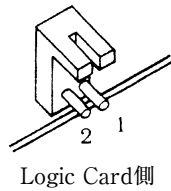

ピン番号	信号名
1	Form Feed Motor +A相
2	Form Feed Motor -A相
3	Form Feed Motor +B相
4	Form Feed Motor -B相
5	Form Feed Motor Common
6	Form Feed Motor Common

図 7-4. コネクターJ2 (Form Feed Motor)

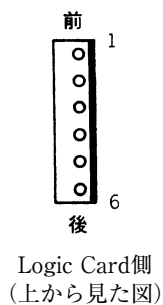

ピン番号	信号名
1	Cam Motor+A相
2	Cam Motor-A相
3	Cam Motor+B相
4	Cam Motor-B相
5	Cam Motor Common
6	Cam Motor Common
7	(Blank)

図 7-5. コネクターJ3 (Cam Motor)

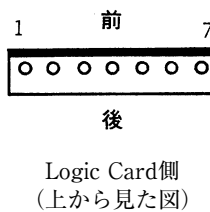

ピン番号	信号名
1	Print Data 1 Magnet
2	Print Data 3 Magnet
3	Print Data 7 Magnet
4	Print Data 5 Magnet
5	Print Data 11 Magnet
6	Print Data 9 Magnet
7	Print Data 15 Magnet
8	Print Data 13 Magnet
9	Head Common (1,5,9)
10	Print Data 17 Magnet
11	Head Common (3,7,11)
12	Print Data 19 Magnet
13	Head Common (13,17,21)
14	Print Data 21 Magnet
15	Head Common (15,19,23)
16	Print Data 23 Magnet
17	+Print Head Heat Detect
18	Signal Ground
19	(Blank)
20	(Blank)

ピン番号	信号名
21	Head Common (16,20,24)
22	Print Data 24 Magnet
23	Head Common (14,18,22)
24	Print Data 22 Magnet
25	Head Common (4,8,12)
26	Print Data 20 Magnet
27	Head Common (2,6,10)
28	Print Data 18 Magnet
29	Print Data 16 Magnet
30	Print Data 14 Magnet
31	Print Data 12 Magnet
32	Print Data 10 Magnet
33	Print Data 8 Magnet
34	Print Data 6 Magnet
35	Print Data 2 Magnet
36	Print Data 4 Magnet
37	Signal Ground
38	- Paper Edge Sensor Output
39	Paper Edge Sensor Anode
40	Frame Ground

図 7-6. コネクターJ4 (Print Head)

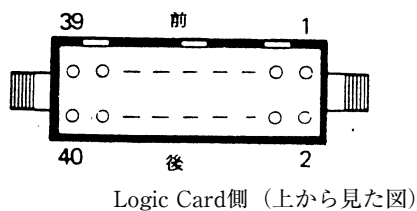

ピン番号	信号名
1	Cam Initial Position Sensor Output
2	Signal Ground
3	Cam Initial Position Sensor Anode
4	Signal Ground

図 7-7. コネクタ-J5 (Cam Initial Position Sensor)

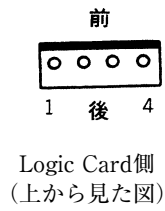

ピン番号	信号名
1	AGA Gap Motor +A相
2	AGA Gap Motor -A相
3	AGA Gap Motor +B相
4	AGA Gap Motor -B相
5	AGA Gap Motor Common
6	AGA Gap Motor Common

図 7-8. コネクタ-J7 (AGA Gap Motor)

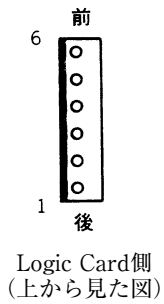

ピン 番号	信号名
1	+40V for Head Driver
2	+40V for Head Driver
3	+40V for Motor Driver
4	Return of 40V
5	Return of 40V
6	Return of 40V
7	Signal Ground
8	Signal Ground
9	+5V
10	+5V

図 7-9. コネクターJ8 (Power)

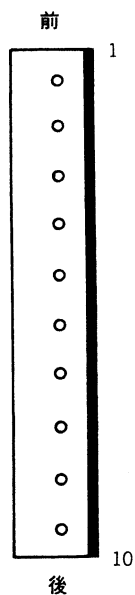

Logic Card側 (上から見た図)

ピン 番号	信号名
1	- Power Save
2	Signal Ground
3	- Power With Low Power Mode

図 7-10. コネクターJ18 (Power Save)

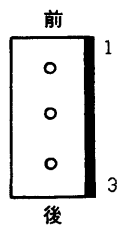

Logic Card側 (上から見た図)

ピン 番号	信号名
1	OP. +5V
2	OP. Panel Data 0
3	OP. Panel Data 1
4	Signal Ground
5	OP. Panel Data 2
6	OP. Panel Data 3
7	OP. Panel Data 4
8	OP. Panel Data 5
9	OP. +5V
10	OP. Panel Data 6
11	OP. Panel Data 7
12	Signal Ground
13	OP. Panel Chip Select RD 0
14	OP. Panel Chip Select RD 1
15	OP. Panel Chip Select RD 2
16	OP. Panel Chip Select WR 0
17	OP. +5V
18	OP. Panel Chip Select WR 1
19	OP. Panel Chip Select WR 2
20	Signal Ground



図 7-11. コネクターJ9 (Operator Panel)

ピン 番号	信号名
1	+Sense Paper End
2	Signal Ground
3	Sensor Anode

図 7-12. コネクタJ10 (EOF Switch)

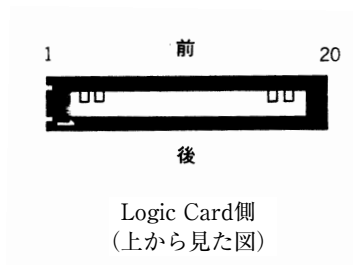
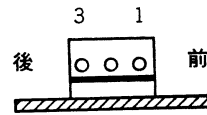

Logic Card側
(ピン側から見た図)

ピン 番号	信号名
1	TOF Sensor Anode
2	TOF Sensor Output
3	Signal Ground
4	+5V
5	BOF Sensor Anode
6	BOF Sensor Output
7	Signal Ground

図 7-13. コネクタJ11 (TOF/BOF Sensor)

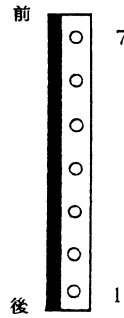

Logic Card側 (上から見た図)

ピン 番号	信号名
1	+Encoder A
2	+Encoder B
3	+5V
4	Signal Ground
5	Signal Ground

図 7-14. コネクタJ12 (CM Encoder)

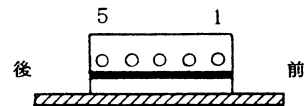

Logic Card側
(ピン側から見た図)

ピン番号	信号名
1	+ASF Lift Motor A
2	+ASF Lift Motor B
3	-ASF Lift Motor On
4	-Lift Up
5	-ASF Connect
6	+ASF Auto (-DID)
7	+Motor Common
8	+Drive Ready
9	-Lift Low
10	+5V
11	Signal Ground
12	+40V
13	Machine 0V
14	-ASF Clutch On

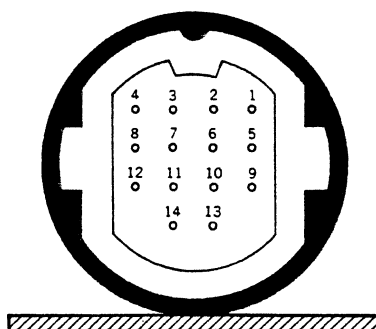

Logic Card側
(後から見た図)

図 7-15. コネクターJ14 (ASF)

ピン番号	信号名
1	AGA Home Position Sensor Out
2	AGA Home Position Sensor Anode
3	Signal Ground
4	Signal Ground

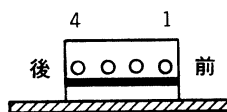

Logic Card側
(ピン側から見た図)

図 7-16. コネクターJ15 (AGA Home Position Sensor)

ピン 番号	信号名
1	-Print Data 1 Magnet
2	-Print Data 7 Magnet
3	-Print Data 11 Magnet
4	-Print Data 15 Magnet
5	+Head Common (1, 5, 9)
6	+Head Common (3, 7, 11)
7	+Head Common (13, 17, 21)
8	+Head Common (15, 19, 23)
9	Print Head Heat Detect
10	+Head Common (16, 20, 24)
11	+Head Common (14, 18, 22)
12	+Head Common (4, 8, 12)
13	+Head Common (2, 6, 10)
14	-Print Data 16 Magnet
15	-Print Data 12 Magnet
16	-Print Data 8 Magnet
17	-Print Data 2 Magnet

ピン 番号	信号名
18	-Print Data 4 Magnet
19	-Print Data 6 Magnet
20	-Print Data 10 Magnet
21	-Print Data 14 Magnet
22	-Print Data 18 Magnet
23	-Print Data 20 Magnet
24	-Print Data 22 Magnet
25	-Print Data 24 Magnet
26	Signal Ground
27	-Print Data 23 Magnet
28	-Print Data 21 Magnet
29	-Print Data 19 Magnet
30	-Print Data 17 Magnet
31	-Print Data 13 Magnet
32	-Print Data 9 Magnet
33	-Print Data 5 Magnet
34	-Print Data 3 Magnet

図7-17. コネクター J21 (Print Head)

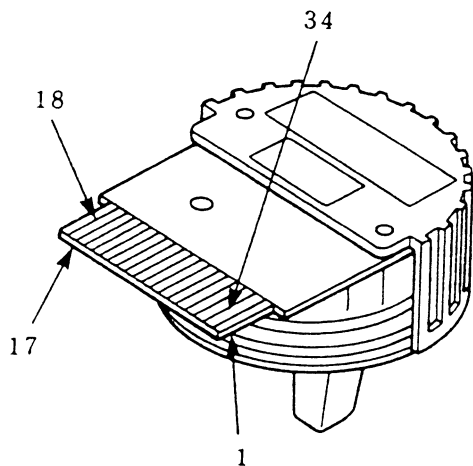

ピン 番号	信号名
1	Paper Edge Sensor Anode
2	- Paper Edge Sensor Output
3	Signal Ground



図 7-18. コネクターJ22 (Sensor)

ピン 番号	信号名
TP7	CM Encoder Phase B
TP9	CM Encoder Phase A
GND	Signal Ground
+5V	+5V
H40V	+40V (Head)
HM0V	Analog Ground
HD-	Head Heat
HEAT	
M40V	+40V (Motor)

図 7-19. Logic CardのTest Points

IBM 5577-V02用 ASF Card のコネクタの接続図と、各コネクタのピン配列を以下に示している。
なお、各図中のピン番号配置図は、カード上面から見たコネクタの状態を表している。



図 7-20. ASF Card のコネクタ配置図



図 7-21. ASF の Wiring Diagram

ピン 番号	信号名
1	+ASF Lift Motor A
2	+ASF Lift Motor B
3	-ASF Motor On
4	-Lift Up
5	-ASF Connect
6	+ASF Auto (-DID)
7	+Motor Common
8	+Drive Ready
9	-Lift Low
10	+5V
11	+5V
12	Signal Ground
13	Signal Ground
14	+40V
15	+40V
16	+40V
17	Machine 0V
18	Machine 0V
19	Machine 0V
20	-ASF Clutch On

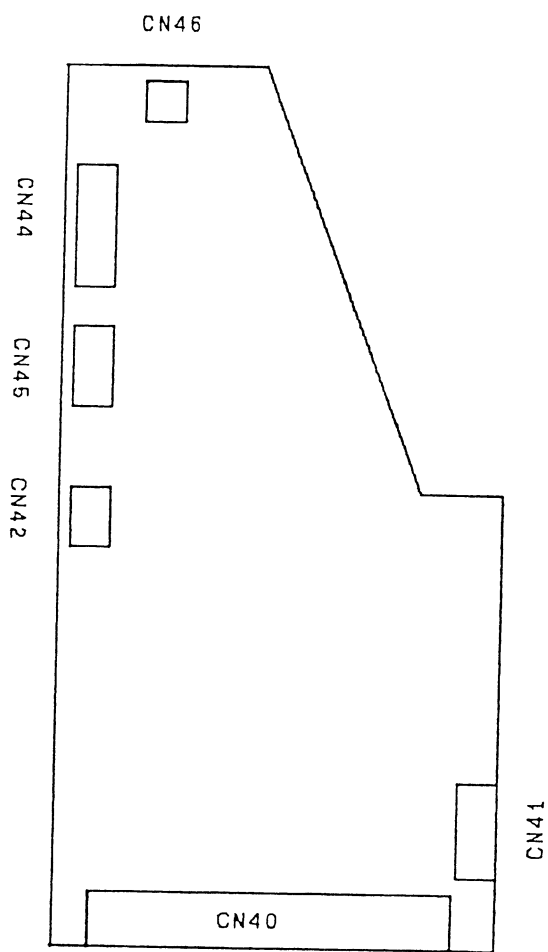
図 7-22. コネクター-CN40 (ASF Card)

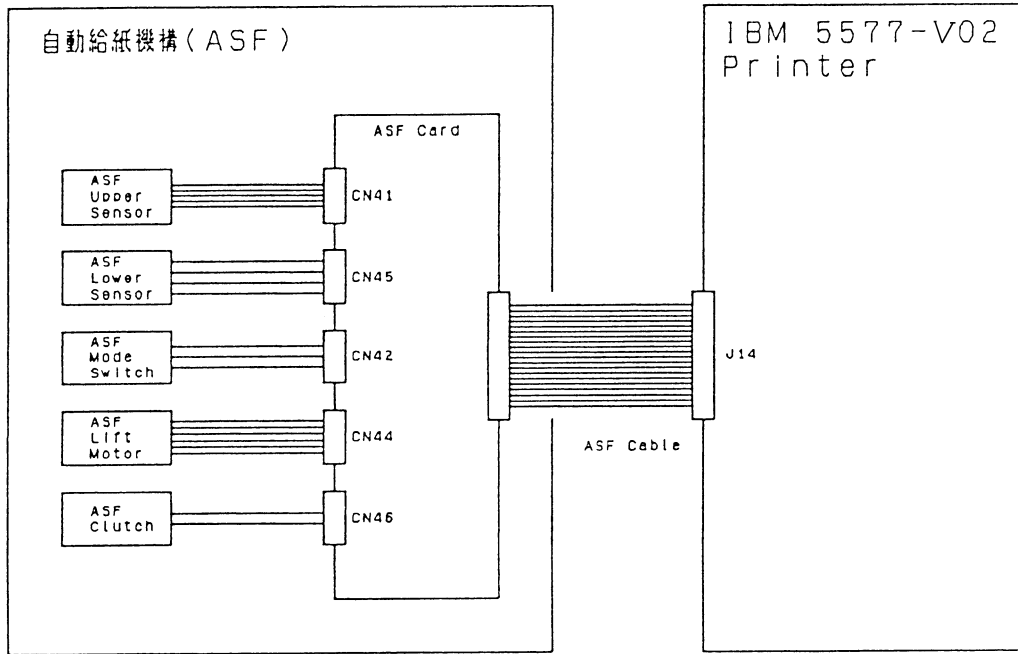
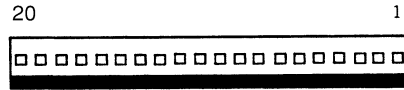

ASF Card側

ピン 番号	信号名
1	+Lift Up
2	Signal Ground
3	Sensor Anode
4	Signal Ground
5	Signal Ground

図 7-23. コネクター-CN41 (Upper Sensor)

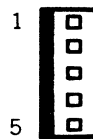

ASF Card側

ピン 番号	信号名
1	+ASF Auto (-DID)
2	Signal Ground
3	+5V

図 7-24. コネクター-CN42 (Mode Switch)



ASF Card側

ピン番号	信号名
1	Lift Motor +A相
2	Lift Motor -A相
3	Lift Motor +B相
4	Lift Motor -B相
5	Lift Motor Common
6	Lift Motor Commom



図 7-25. コネクターCN44 (Lift Motor)

ピン番号	信号名
1	-Lift Low
2	Signal Ground
3	+5V
4	(Blank)

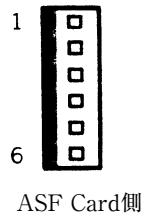

図 7-26. コネクターCN45 (Lower Sensor)

ピン番号	信号名
1	Clutch Drive
2	Machine 0V



図 7-27. コネクターCN46 (ASF Clutch)

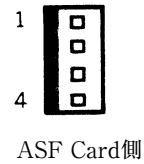
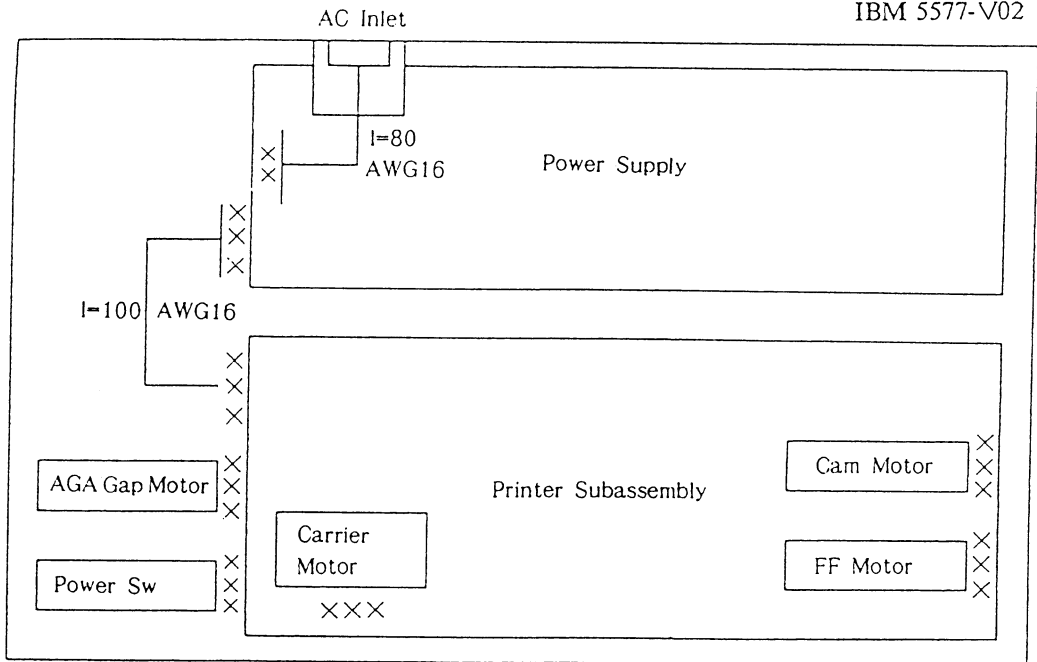

注：

1. ×××... Screw & Washer
2. ×× ... Screw & Star-Washer

図 7-28. IBM 5577-V02 の AC Grounding Diagram

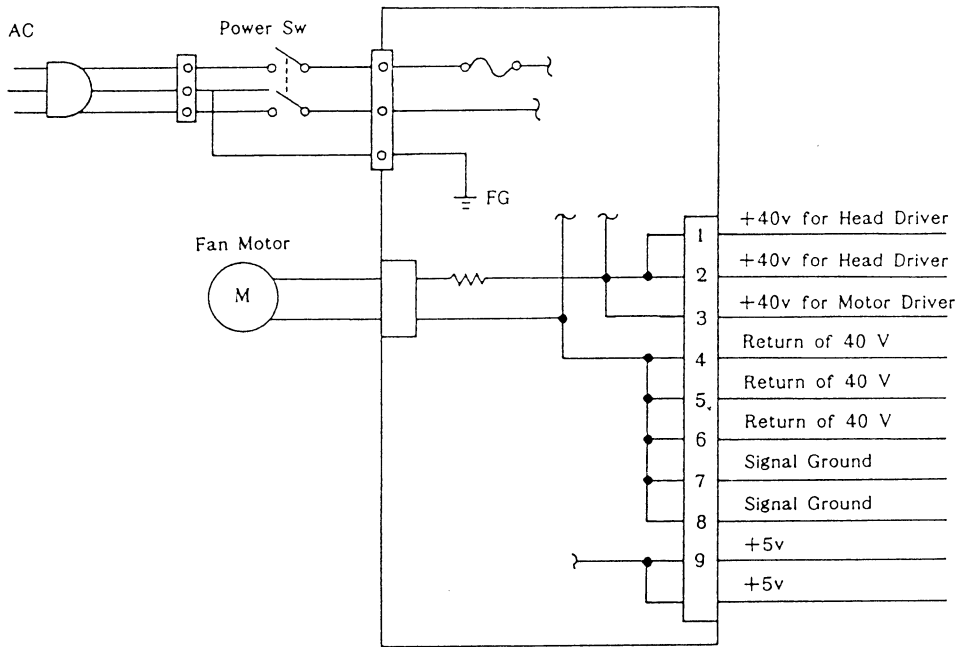

図 7-29. Power Supply Wiring Diagram

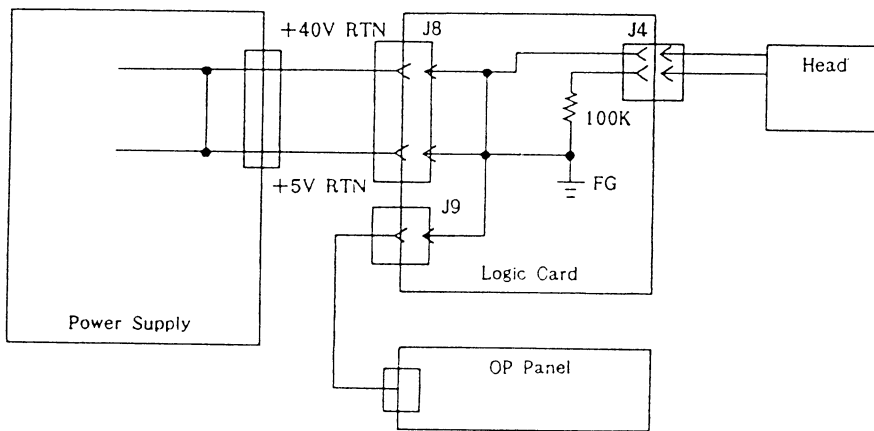

図 7-30. DC Grounding Diagram