

IBM VSE/Enterprise Systems Architecture



# VSE/ESA Release Guide

*Version 2 Release 7 Modification Level 2*



IBM VSE/Enterprise Systems Architecture



# VSE/ESA Release Guide

*Version 2 Release 7 Modification Level 2*

**Note!**

Before using this information and the product it supports, be sure to read the general information under "Notices" on page vii.

**Ninth Edition (July 2004)**

This edition applies to Version 2 Release 7 Modification Level 2 of IBM Virtual Storage Extended/Enterprise Systems Architecture (VSE/ESA), Program Number 5690-VSE, and to all subsequent releases and modifications until otherwise indicated in new editions.

Order publications through your IBM representative or the IBM branch office serving your locality. Publications are not stocked at the addresses given below.

A form for readers' comments is provided at the back of this publication. If the form has been removed, address your comments to:

IBM Deutschland Entwicklung GmbH  
Department 3248  
Schoenaicher Strasse 220  
D-71032 Boeblingen  
Federal Republic of Germany

You may also send your comments by FAX or via the Internet:

Internet: [s390id@de.ibm.com](mailto:s390id@de.ibm.com)  
FAX (Germany): 07031-16-3456  
FAX (other countries): (+49)+7031-16-3456

When you send information to IBM, you grant IBM a non-exclusive right to use or distribute the information in any way it believes appropriate without incurring any obligation to you.

© Copyright International Business Machines Corporation 2000, 2004. All rights reserved.

US Government Users Restricted Rights – Use, duplication or disclosure restricted by GSA ADP Schedule Contract with IBM Corp.

# Contents

**Figures . . . . . v**

**Notices . . . . . vii**

Trademarks and Service Marks . . . . . vii

**About This Book. . . . . ix**

Who Should Use This Book . . . . . ix

How to Use This Book . . . . . ix

Where to Find More Information . . . . . ix

**Chapter 1. VSE/ESA 2.7.2 and Other 2.7 Items . . . . . 1**

Softcopy-Only Availability (VSE/ESA 2.7.2 Onwards) 2

Some Programs No Longer Orderable (VSE/ESA 2.7.2 Onwards) . . . . . 2

Support for zSeries 890 and 990 Hardware . . . . . 3

Enhanced Support for the zSeries 890 and 990 Processors . . . . . 3

Support for the 3592 J1A Tape Drive . . . . . 4

    Changes to the IPL . . . . . 4

    Changes to the JCL ASSGN Statement . . . . . 4

    Changes to Macros . . . . . 4

    Using a 3592 Tape Drive in a 3494 Tape Library . . . . . 5

Simplified Procedure for Setting Up for SSL Support 5

Support for DB2 Version 7 Release 3 . . . . . 5

VSE/POWER: Disable the Display of Unimportant Messages . . . . . 5

VSE/POWER: SET NORUN=YES for Dynamic Partitions With Max-Active=1. . . . . 7

VSE/POWER: Elimination of DBLK Tracing Performance Impact . . . . . 7

VSE/POWER: Extended Number of IPWSEGM Spooling Macro Attributes . . . . . 8

VSE/POWER: Improved PNET TCP/IP Firewall Support . . . . . 9

Hardware Crypto Support . . . . . 10

    Support Characteristics . . . . . 10

    Using the Crypto Support with a VSE/ESA Guest under z/VM . . . . . 11

    Using the Crypto Support and an External Security Manager . . . . . 12

HiperSockets Support . . . . . 13

    Support Overview . . . . . 13

    Invoking the Support . . . . . 13

    Further Documentation . . . . . 15

Interactive Interface Enhancements . . . . . 16

    Configure Hardware Dialog (Fastpath 241) . . . . . 16

    Dump Management Dialog (Fastpath 43) . . . . . 16

SVA and CICS DSA Space Enhancements . . . . . 18

TotalStorage ESS Enhanced Support . . . . . 18

VSE/VSAM Support of Large DASDs . . . . . 19

    Making Use of the Support . . . . . 19

    Migrating to Large DASDs Using IDCAMS Backup/ Restore. . . . . 20

    Performance Considerations (KSDS Only) . . . . . 20

    Increased Size of the Catalog Index . . . . . 21

    Restrictions for VSE/VSAM Support of Large DASDs . . . . . 21

    New or Changed Fields in LISTCAT Output . . . . . 21

Information Moved From This Chapter . . . . . 23

    Information Moved to the VSE/ESA Administration . . . . . 23

    Administration . . . . . 23

**Chapter 2. VSE/ESA 2.6 Items . . . . . 25**

OSA Express Support . . . . . 25

    Introduction . . . . . 25

    Invoking the Support . . . . . 26

    Further Documentation . . . . . 28

Initial Installation Enhancements . . . . . 29

IPL Enhancement . . . . . 30

    Deleting Unexpired Secured System Files during IPL . . . . . 30

Interactive Interface Enhancements . . . . . 31

    TCP/IP Configuration (Fastpath 246) . . . . . 31

    Configure Hardware (Fastpath 241) . . . . . 31

    Compile Job Generation (Fastpath 51) . . . . . 32

SDAID XPCC Trace. . . . . 33

    TRACE XPCC Command . . . . . 33

SDAID GETVIS/FREEVIS Trace . . . . . 35

    TRACE GETVIS Command . . . . . 35

    Initializing the Trace with Procedure SDGETV. . . . . 36

    Trace Output Example. . . . . 36

TERSE Utility. . . . . 38

Virtual Tape Support . . . . . 40

    VSE/VSAM or Remote Virtual Tape . . . . . 40

    Defining the Tape Device. . . . . 40

    VTAPE Command . . . . . 40

    Functional Components of the Virtual Tape Support . . . . . 40

    Startup of the Virtual Tape Data Handler . . . . . 41

    Installing the Virtual Tape Server . . . . . 42

    Important Considerations When Using Virtual Tapes . . . . . 45

    Working with VSE/VSAM Virtual Tapes. . . . . 45

    Working with Remote Virtual Tapes . . . . . 48

    Examples of Using Virtual Tapes . . . . . 49

    The VTAPE Command/Statement . . . . . 51

Information Moved From This Chapter . . . . . 53

    Information Moved to the VSE/ESA Administration . . . . . 53

    Information Moved to the VSE/ESA Administration . . . . . 53

    Information Moved to the VSE/ESA Administration . . . . . 53

    Programming and Workstation Guide . . . . . 53

**Chapter 3. VSE/ESA 2.5 Items . . . . . 55**

Interactive Interface Enhancements . . . . . 56

    Manage Batch Queues (Fastpath 32) . . . . . 56

    In-Creation Queue (Fastpath 326) . . . . . 56

    Primary Library and Secondary Library (Fastpath 51) . . . . . 57

    Storage Dump Management (Fastpath 43) . . . . . 57

Display Channel and Device Activity (Fastpath 362) . . . . .	58
VSE/VSAM Buffer Hashing . . . . .	59
What Is Buffer Hashing? . . . . .	59
How Does Buffer Hashing Work? . . . . .	59
Miscellaneous Improvements . . . . .	60
Information Moved From This Chapter . . . . .	61
Information Moved to the VSE/ICCF User's Guide . . . . .	61

**Chapter 4. IXFP/SnapShot and FlashCopy Support . . . . . 63**

Shipment and Installation of FlashCopy and IXFP/SnapShot Support . . . . .	63
Fast Service Upgrade (FSU) Considerations. . . . .	64
Hardware Prerequisites . . . . .	64
Operation . . . . .	64
IXFP Command . . . . .	64
Command Syntax . . . . .	65
SNAP (RVA and ESS) . . . . .	65
DDSR (RVA only) . . . . .	67
REPORT (RVA only) . . . . .	69
IXFP Report Data Sample. . . . .	69
IXFP Report Data . . . . .	69
VSE/Fast Copy (FCOPY) Exploitation of FlashCopy and SnapShot. . . . .	72
Job Stream Example . . . . .	72

Using IXFP/SnapShot to Backup VSE/VSAM Datasets . . . . .	73
Background . . . . .	73
Prerequisites . . . . .	73
Advantages in Creating a SnapShot of Entire Disk Volumes. . . . .	73
Using IDCAMS SNAP and BACKUP With a Synonym List. . . . .	74
Example of Running IDCAMS SNAP /BACKUP With a Synonym List . . . . .	76
Usage of IXFP/SnapShot with VM Minidisks . . . . .	77
Operating in Batch . . . . .	77

**Chapter 5. Publication Updates . . . . . 79**

VSE/ESA System Control Statements. . . . .	79
VSE/ESA System Macros Reference . . . . .	79
VSE/ESA Guide to System Functions. . . . .	80
VSE/ESA Guide for Solving Problems . . . . .	80
VSE/ESA System Utilities . . . . .	81
VSE/VSAM Commands . . . . .	81
VSE/VSAM User's Guide and Application Programming. . . . .	81
VSE/ESA Library Control Device Driver for IBM 3494. . . . .	81

**Index . . . . . 83**

---

## Figures

1. Selecting an OSAX Device . . . . .	16	11. Prepare for Installation Dialog . . . . .	50
2. Defining the MODE for a HiperSockets Device	16	12. Panel for Defining Virtual Tape Details	51
3. Selecting Dumps to be Deleted . . . . .	17	13. Syntax of VTAPE START and VTAPE STOP Command/Statement . . . . .	51
4. TCP/IP Configuration Dialog . . . . .	31	14. Manage Batch Queue Dialog . . . . .	56
5. Selection Panel for OSAX . . . . .	32	15. In-Creation Queue Dialog . . . . .	57
6. Compile Job Generation Panel . . . . .	32	16. Select CICS TS or CICS/VSE. . . . .	58
7. Skeleton SKVTASTJ (for Starting the Virtual Tape Data Handler). . . . .	41	17. Specify Dump Levels for CICS TS Dumps	58
8. Selecting the Components of the Virtual Tape Server . . . . .	44	18. IXFP Command Syntax . . . . .	65
9. Skeleton SKVTAPE . . . . .	46	19. Internal Structure of Synonym List. . . . .	76
10. Job Stream Example for Backing Up a VSE/ESA Library . . . . .	49		





---

## Notices

References in this publication to IBM products, programs, or services do not imply that IBM intends to make these available in all countries in which IBM operates. Any reference to an IBM product, program, or service is not intended to state or imply that only that IBM product, program, or service may be used. Any functionally equivalent product, program, or service that does not infringe any of the intellectual property rights of IBM may be used instead of the IBM product, program, or service. The evaluation and verification of operation in conjunction with other products, except those expressly designated by IBM, are the responsibility of the user.

IBM may have patents or pending patent applications covering subject matter in this document. The furnishing of this document does not give you any license to these patents. You can send license inquiries, in writing, to the IBM Director of Licensing, IBM Corporation, North Castle Drive, Armonk, NY 10504-1785, U.S.A.

Any pointers in this publication to non-IBM Web sites are provided for convenience only and do not in any manner serve as an endorsement. IBM accepts no responsibility for the content or use of non-IBM Web sites specifically mentioned in this publication or accessed through an IBM Web site that is mentioned in this publication.

Licensees of this program who wish to have information about it for the purpose of enabling: (i) the exchange of information between independently created programs and other programs (including this one) and (ii) the mutual use of the information which has been exchanged, should contact:

IBM Deutschland GmbH  
Department 0790  
Pascalstr. 100  
70569 Stuttgart  
Germany

Such information may be available, subject to appropriate terms and conditions, including in some cases payment of a fee.

---

## Trademarks and Service Marks

The following terms are trademarks of International Business Machines Corporation in the United States, or other countries, or both:

CICS	RAMAC
DataPropagator	Redbooks
DB2	RS/6000
ECKD	SAA
Enterprise Storage Server	System/390
FICON	S/390
FlashCopy	TotalStorage
HiperSockets	VM/ESA
IBM	VSE/ESA
Multiprise	VTAM
OS/2	zSeries
OS/390	z/VM

QMF

UNIX is a registered trademark of The Open Group in the United States and other countries.

Linux is a trademark of Linus Torvalds in the United States, other countries, or both.

Microsoft, Windows, Windows NT and the Windows logo are trademarks of Microsoft Corporation in the United States, and/or other countries.

Java and all Java-based trademarks are trademarks of Sun Microsystems, Inc. in the United States, other countries, or both.

SnapShot is a trademark of Storage Technology Corporation for a duplication product.

Other company, product, and service names, may be trademarks or service marks of others.

---

## About This Book

This manual provides details of the enhancements and changes implemented with IBM Virtual Storage Extended/Enterprise Systems Architecture, Version 2, Release 7 Modification Level 2 (VSE/ESA 2.7.2).

It also provides a description of functions introduced with VSE/ESA 2.7, VSE/ESA 2.6, and VSE/ESA 2.5, and that are not described in other manuals.

---

## Who Should Use This Book

This manual is intended for those VSE/ESA users who need to be aware of important information provided with VSE/ESA Version 2 Release 7 Modification Level 2.

---

## How to Use This Book

The book includes the following chapters:

- Chapter 1, "VSE/ESA 2.7.2 and Other 2.7 Items," on page 1.
- Chapter 2, "VSE/ESA 2.6 Items," on page 25.
- Chapter 3, "VSE/ESA 2.5 Items," on page 55.
- Chapter 4, "IXFP/SnapShot and FlashCopy Support," on page 63.
- Chapter 5, "Publication Updates," on page 79.

---

## Where to Find More Information

Whenever appropriate, the book refers to other VSE/ESA manuals that provide further details on a specific topic.

The VSE/ESA home page provides additional VSE/ESA information:

### **VSE/ESA Home Page**

VSE/ESA has a home page on the World Wide Web, which offers up-to-date information about VSE-related products and services, new VSE/ESA functions, and other items of interest to VSE users.

You can find the VSE/ESA home page at:

<http://www.ibm.com/servers/eserver/zseries/os/vse/>



---

## Chapter 1. VSE/ESA 2.7.2 and Other 2.7 Items

This chapter describes the items introduced with VSE/ESA 2.7.2, 2.7.1, and 2.7.0 (2.7).

**Note!**

This edition of the VSE/ESA Release Guide differs from the previous (suffix 07) edition to include the VSE support you require in order to use the **zSeries 890 processor**.

These are the items in this chapter:

- “Softcopy-Only Availability (VSE/ESA 2.7.2 Onwards)” on page 2
- “Some Programs No Longer Orderable (VSE/ESA 2.7.2 Onwards)” on page 2
- “Support for zSeries 890 and 990 Hardware” on page 3
- “Enhanced Support for the zSeries 890 and 990 Processors” on page 3
- “Support for the 3592 J1A Tape Drive” on page 4
- “Simplified Procedure for Setting Up for SSL Support” on page 5
- “Support for DB2 Version 7 Release 3” on page 5
- “VSE/POWER: Disable the Display of Unimportant Messages” on page 5
- “VSE/POWER: SET NORUN=YES for Dynamic Partitions With Max-Active=1” on page 7
- “VSE/POWER: Elimination of DBLK Tracing Performance Impact” on page 7
- “VSE/POWER: Extended Number of IPWSEGM Spooling Macro Attributes” on page 8
- “VSE/POWER: Improved PNET TCP/IP Firewall Support” on page 9
- “Hardware Crypto Support” on page 10
- “HiperSockets Support” on page 13
- “Interactive Interface Enhancements” on page 16
- “SVA and CICS DSA Space Enhancements” on page 18
- “TotalStorage ESS Enhanced Support” on page 18
- “VSE/VSAM Support of Large DASDs” on page 19
- “Information Moved From This Chapter” on page 23

---

## Softcopy-Only Availability (VSE/ESA 2.7.2 Onwards)

From VSE/ESA 2.7.2 onwards, **all** VSE/ESA manuals will be available as **softcopy only**. This includes LE/VSE manuals, VSE/POWER manuals, CICS Transaction Server for VSE/ESA manuals, and so on.

You can now obtain softcopy VSE/ESA manuals from either the:

- VSE Collection CD-ROM, SK2T-0060.
- IBM Publications Center, which has this internet URL:  
<http://www.elink.ibm.link.ibm.com/public/applications/publications/cgibin/pbi.cgi>

From the IBM Publications Center, you can download most VSE/ESA online publications free-of-charge in PDF or BOOK format. You can also order hardcopies of VSE/ESA manuals that were published before VSE/ESA 2.7.2, providing they are still available.

---

## Some Programs No Longer Orderable (VSE/ESA 2.7.2 Onwards)

The VSE/ESA optional programs listed in Table 1 can no longer be ordered together with VSE/ESA. The reason is that they are no longer marketed by IBM.

However, if you still need to use a withdrawn program (and cannot use the replacement), you can:

1. Obtain the withdrawn optional program from an earlier VSE/ESA Product Tape.
2. Apply the most current service for this program (if available).

*Table 1. VSE/ESA Optional Programs That Have Been Withdrawn*

VSE/ESA Optional Program (Withdrawn)	Replacement Optional Program
ACF/NCP 5.4.0 (5668-738)	ACF/NCP 7.8.1 (5648-063)
ACF/NCP 4.3.1 (5668-854)	ACF/NCP 7.8.1 (5648-063)
DB2 Server for VM and VSE Version 7 Release 2 (including Data Propagator) (5697-F42)	DB2 Server for VM and VSE Version 7 Release 3 (5697-F42)
Emulator Program 1.9.0 (5735-XXB)	Emulator Program 1.14.0 (5735-XXB)
NetView V2 (5686-055)	No replacement
SDF/CICS 1.5.0 (5746-XXT)	SDF II 1.6.0 (5746-XXT)
X.25 NPSI 2.1.0 (5668-719)	X.25 NPSI 3.9.0 (5688-035)
X.25 NPSI 3.4.0 (5688-035)	X.25 NPSI 3.9.0 (5688-035)

---

## Support for zSeries 890 and 990 Hardware

To use VSE/ESA with zSeries 890 hardware, these APARs must be installed:

- DY45944 (for VSE Central Functions code)
- DY45958 (for VSE Central Functions code)
- DY46105 (for IOCP code)
- PQ86795 (for OSA/SF code)
- DY45940 (for EREP code)

### Notes:

1. The above APARs apply to both VSE/ESA 2.6 and VSE/ESA 2.7. However, before you install the z890 hardware, please confirm that these APARs have been successfully installed.
2. The APAR DY45944 is already integrated into the VSE/ESA 2.7.0 system.

To use VSE/ESA with zSeries 990 hardware, these APARs must be installed:

- DY45944 (for VSE Central Functions code)
- DY45958 (for VSE Central Functions code)
- DY45924 (for IOCP code)
- PQ73567 (for OSA/SF code)
- DY45940 (for EREP code)

### Notes:

1. The above APARs apply to both VSE/ESA 2.6 and VSE/ESA 2.7. However, before you install the z990 hardware, please confirm that these APARs have been successfully installed.
2. The APAR DY45944 is already integrated into the VSE/ESA 2.7.0 system.
3. From VSE/ESA 2.7.1 onwards, the above APARs are *already* integrated into VSE/ESA.

For a description of OSA Express support from VSE/ESA 2.6 onwards, see page 25.

---

## Enhanced Support for the zSeries 890 and 990 Processors

With the installation of APAR DY45958, VSE/ESA support for the IBM eServer zSeries 890 and 990 processors is enhanced. This includes support for:

- Up to 30 LPARs (Logical Partitions) in which VSE/ESA can run.
- Up to two Logical Channel Subsystems (LCSS).
- “Spanned” HiperSockets (that is, HiperSockets that connect LPARs using different Logical Channel Subsystems).

With the installation of APAR DY46075, VSE/ESA 2.7 also supports Adapter Interruption for OSA Express. The OSA Express adapter is based on the QDIO architecture. Originally the OSA Express adapter generated a PCI interruption after data was placed into the QDIO input queue.

With the IBM eServer zSeries 990 (available since October 2003) and zSeries 890, the QDIO-adapter interruption facility is available for OSA Express adapters. When available, VSE/ESA will use the QDIO-adapter interruption facility, which is faster than the PCI interruption.

## Support for the 3592 J1A Tape Drive

This section describes how you can use the *IBM TotalStorage Enterprise Tape Drive 3592 Model J1A* together with VSE/ESA 2.7 and VSE/ESA 2.6.

### Notes:

1. To use 3592 tape drive support, you must first install APAR DY46071.
2. To also use the *Interactive User Interface* with the 3592 tape drive support, you must install APARs PQ80873 and PQ80874.

After applying PTF DY46071, a 3592 J1A tape drive can then also be used, when attached to an *IBM TotalStorage Enterprise Automated Tape Library 3494*.

The 3592 J1A tape drive requires new cartridges, which are now supported by VSE/ESA. The new cartridges are written in 512-track format.

## Changes to the IPL

To add the 3592 J1A drives to the startup procedure, you must specify an additional mode:

```
ADD cuu,TPA,5
```

You must also ADD a 3592 tape drive to VSE/ESA as TPA,5 if the following are both true:

- A 3592 tape drive is to be used from a VSE/ESA system running under VM.
- The 3592 is not attached during the startup of the VSE/ESA operating system.

## Changes to the JCL ASSGN Statement

With the introduction of 3592 tape drive support, a new device class **TPAT512** can be used with the ASSGN statement, where TPAT512 identifies a 3592 tape drive. The ASSGN statement has this format:

```
ASSGN SYSnnn device type code
```

In a mixed 3590/3592 tape drive environment (that is, there are different 3590/3592 models with different track characteristics, such as 128-track, 256-track, 384-track, and 512-track), you must specify ASSGN SYSnnn,TPAT512 to ensure that a 3592 tape drive with 512-track characteristic is selected.

You should be aware that a generic ASSGN SYSnnn,TPA statement will use this search order:

1. Eligible TPAT128 devices.
2. TPAT256 devices.
3. TPAT384 devices.
4. TPAT512 devices.

## Changes to Macros

The LBSERV macro calls for SQUERY, AQUERY and IQUERY requests will return in SERVL ("service list") IJLBSER, a media type IJLTMED of CST5 for all 3592 devices.

VSE/ESA supports 3592 J1A tape drives as follows:

<b>External device code</b>	TPA
<b>VSE Pub device type code</b>	X'56'
<b>Library Media code</b>	C'CST5'



The EXTRACT macro call `ID=ATLCUU` which requests a free 3592 tape drive in an automated tape library, will require this input:

- 3490E for the 3490E drive.
- TPA for the 3590 drive.
- EFMT1 for the 3592 drive.

**Related Information:**

“VSE/ESA System Macros Reference” on page 79

## Using a 3592 Tape Drive in a 3494 Tape Library

You can use a 3592 tape drive in a 3494 tape library providing you install the APAR VM63325 on z/VM. The tape drive support is made through the VSE Guest Server (VGS). The VGS is supported by DFSMS/RMS.

**Note:** 3592 support is **not** available using the LCDD (Library Control Device Driver).

## Simplified Procedure for Setting Up for SSL Support

This item is introduced with VSE/ESA 2.7.2.

The procedure for setting up your VSE/ESA and CICS systems to use Secure Sockets Layer (SSL) support has changed. It now includes the use of a tool called **Keyman/VSE**, which you can use to generate SSL keys and certificates. The use of Keyman/VSE simplifies and consolidates the procedures relating to server and client authentication.

You can find details of the changed procedures for setting up for SSL in these manuals:

- *VSE/ESA e-business Connectors User's Guide*, SC33-6719.
- *CICS Transaction Server for VSE/ESA, Enhancements Guide*, GC34-5763.

## Support for DB2 Version 7 Release 3

From VSE/ESA 2.7.1 onwards, the DB2 Server for VSE Version 7 Release 3 is shipped on the VSE/ESA Extended Base Tape. The installation and Fast Service Upgrade (FSU) establish this new release of the DB2 Server for VSE.

These are the relevant changes to the VSE/ESA manuals:

- The DB2-based connector examples have been updated accordingly in the *VSE/ESA e-business Connectors User's Guide*.
- The dialogs described in the *VSE/ESA Administration* that are used for compilation now refer to DB2 Server for VSE Version 7 Release 3.

## VSE/POWER: Disable the Display of Unimportant Messages

This item is introduced with APAR DY46030.

You can use the PVAR command to allow the operator to disable (suppress) most VSE/POWER messages from being displayed on the system console. As a result, the system console is not cluttered by unimportant “informational” type of messages.

**Note:** The console hardcopy file is not affected by this action.

## VSE/POWER

In addition, the operator can query the system to determine which messages have been disabled. These messages can later be enabled by the operator.

To vary the display of a message on the console, you can enter these types of commands:

```
PVARY MSG,mmmmI,NOCONS
```

```
PVARY MSG,mmmmI,CONS
```

```
PVARY MSG,ALLDISAB,SHOW
```

```
PVARY MSG,ALLDISAB,CONS
```

where:

### **mmmmI**

Message prefix which consists of 5 characters with the last character of type code **I**. Only VSE/POWER messages of type **I** are accepted.

**CONS** Causes the message to be displayed on the system console. This is the default.

### **NOCONS**

Causes the message not to be displayed on the system console (but these messages will still be recorded in the hardcopy file). You can **not** specify NOCONS together with ALLDISAB.

### **ALLDISAB**

Causes all previously disabled messages to be either:

- Shown by message 1Q8HI.
- Enabled so they can be displayed on the console.

The message "1Q8HI MESSAGE mmmmI BEEN DISABLED, NOW ENABLED FOR CONSOLE" is issued for each message that was previously disabled using the PVARY MSG command with NOCONS operand.

### **SHOW**

Scans the message module and issues "1Q8HI MESSAGE mmmmI IS DISABLED" for each message that was previously disabled using the PVARY MSG command with NOCONS operand.

### **Notes:**

1. A message is suppressed only on the console. It is *always* recorded in the hardcopy file.
2. If the message is destined for a user or a remote system, the message is sent to its destination.
3. Some important messages are outside the scope of general message support. Such messages cannot be suppressed. For example, messages issued:
  - During the initialization of VSE/POWER.
  - In response to the VSE/POWER command PDISPLAY STATUS.

Therefore, these messages are displayed on the console although the PVARY command has been used to disable them.

4. NOCONS information is kept in module IPW\$\$MM (which is loaded into the VSE/POWER partition) and is valid only for the current VSE/POWER session. When VSE/POWER is next started, all messages are established again for CONS. You can also enter PVARY MSG commands in the VSE/POWER autostart procedure (for example, after the PSTART partition commands). If the PLOAD PHASE command is used to reload module IPW\$\$MM into a running

VSE/POWER system (for example, due to maintenance), all previously-established NOCONS information will be lost.

5. Messages disabled for the console can still be used by “console exits”. For example, REXX console operators or OEM products can still trigger processes based on these messages.

The following command-response messages might be issued:

```
1Q8HI MESSAGE mmmmI BEEN ENABLED, NOW DISABLED FOR
CONSOLE
```

```
1Q8HI MESSAGE mmmmI BEEN DISABLED, NOW DISABLED FOR
CONSOLE
```

```
1Q8HI MESSAGE mmmmI BEEN DISABLED, NOW ENABLED FOR
CONSOLE
```

```
1Q8HI MESSAGE mmmmI BEEN ENABLED, NOW ENABLED FOR
CONSOLE
```

```
1Q8HI MESSAGE mmmmI IS DISABLED
```

For further information about the above messages, refer to the *VSE/ESA Messages and Codes, Volume 1, SC33-6796*.

## VSE/POWER: SET NORUN=YES for Dynamic Partitions With Max-Active=1

This item is introduced with APAR DY46031.

This APAR provides a new optional extension for the SET NORUN=YES autostart statement, as shown below:

```
SET NORUN=YES,DYN1=PAUSE
```

If both of these conditions apply:

1. A failing system crashes during the execution of a job in dynamic class(es) with max-active=1.
2. Another eligible job is queued for the dynamic class(es).

then at system restart:

1. The given job(s) are set to DISP=X.
2. The given dynamic partition(s) enter the 1Q36I // PAUSE mode (for the arranging of the proper sequence in which the jobs should run).

## VSE/POWER: Elimination of DBLK Tracing Performance Impact

This item is introduced with APAR DY46031 and APAR DY46063.

Previous to these APARs, for active DBLK group tracing (normally active for default system configurations), when large spool files were freed after processing, this caused the system to delay spooling until all of the used spool DBLK groups are both:

- Individually written back to disk.
- Placed on the free DBLK group sub-queues (using, for example, the PDELETE LST command).

When no other tasks are active, the DBLK groups are written in “background” back to the disk. Therefore, performance degradation that might result from DBLK group tracing is eliminated.

## VSE/POWER

A new message 1QAGI is generated when the stopping of internal DBLK Group tracing has been rejected:

```
1QAGI 'PSTOP DBLKTR' OBSOLETE - NO LONGER NEEDED
```

The *VSE/ESA Messages and Codes* manual contains this text for the above message 1QAGI (under "SYSTEM ACTION"):

"VSE/POWER ignores this command, because improved deletion of queue entries via "delayed freeing" into the Deletion queue followed by "final freeing" through the init./termination task, does no longer lock spooling resources, nor does it result in poor responsiveness of the PDELETE command. Consequently, the default internal DBLK group tracing remains active for the sake of queue/data file RAS and for first failure capture without impact on spooling performance".

---

## VSE/POWER: Extended Number of IPWSEGM Spooling Macro Attributes

This item is introduced with APAR DY46107.

If you both:

1. use IPWSEGM KEEP=YES,JECL=... to overwrite selected attributes of the first output segment, and then
2. re-establish the overwritten attributes in a later IPWSEGM KEEP=YES,JECL=... request,

you can only perform the above actions for attributes that are returned by IPW\$MXD at offset X'70'.

The DSECT called IPW\$MXD is expanded at the end by X'50' bytes, to contain further attributes belonging to the last segment. Updated macro IPWSEGM operates with the area \$MXD whose length is given by \$MXLEN. The length of variable \$MXLEN has been increased from X'94' to X'E4'. This increased area is identified by a new variable \$MXVRS='VS20' (which was previously 'VS10').

The spooling execution processor (IPW\$\$XWE) feeds additional last-segment attributes in the \$MXD-area only if its \$MXVRS is 'VS20'. Programs that use IPWSEGM must be recompiled if they access the additional attributes.

Additional attributes belonging to the last-created segment can be found at label \$MX2DP, which now contains this additional information:

MX2DP	- Disposition (1 byte),
MX2TDP	- Transmission disposition (1 byte),
MX2PY	- Priority (1 byte),
MX2NC	- Number of copies (1 byte, binary),
MX2SID	- Target SYSID (1 byte, X'00' if empty),
MX2FI	- Forms-id of created segment (4 bytes, X'40' if empty),
MX2FCB	- FCB name (8 bytes, X'00' if empty),
MX2UCS	- UCS name (8 bytes, X'00' if empty),
MX2TN	- Target node (8 bytes, X'40' if empty),
MX2TU	- Target user (8 bytes, X'40' if empty),
MX2DIS	- VM Distribution code (8 bytes, X'40' if empty),
MX2UI	- User Information (16 bytes, X'40' if empty).

If the above additional fields are not empty, then 4-, 8-, and 16-byte character fields are presented left-justified and padded to the right with blanks.

## VSE/POWER: Improved PNET TCP/IP Firewall Support

This item is introduced with APAR DY46015.

Users of a VSE/POWER PNET TCP/IP connection can specify more than one local IP-address by either:

- Specifying an IP-address in the DEFINE LINK TCP/IP statement which is different from the IP-address in the SET IPADDR TCP/IP statement.
- Using a firewall for an internal network with nodes which are known by different IP-addresses to the external network.

The PNODE macro format 4 or 5, which defines directly-linked TCP or SSL nodes, supports an operand IPEXTRAD=external\_ip\_addr. This operand specifies the local host's dotted decimal IP-address, by which the local node is known to the remote node. This operand is meaningful if either of the following are true:

- the local node is known to the remote NJE node via an external IP-address which is different from the local host's internal IP-address. The internal IP-address is the value specified in the TCP/IP statement SET IPADDR=. This internal IP-address is to be used only within an internal network that is usually separated by a firewall from the external network.
- an IP-address has been specified within the local host using the TCP/IP statement DEFINE LINK, which is different from the IP-address specified in the TCP/IP statement SET IPADDR=.

If you use the command PDISPLAY PNET,ALL and IPEXTRAD has been specified for a node, the character 'E' is displayed immediately after the IP-address (without a blank inbetween). For example:

```
1RB7I node-id SSL LINK route2 JOB 4096 009.155.155.125E
```

If you use the command PDISPLAY PNET,node-id and IPEXTRAD has been specified for the node, the character 'E' is displayed immediately after the IP-address (without a blank inbetween), and IPEXTRAD=IP-address is displayed in a second line. For example:

```
pdisplay pnet,power272
```

```
1RB7I POWER272 TCP LINK route2 JOB 4096 009.155.155.125E
1RB7I IPEXTRAD=009.164.155.125
```

If the second line displays a password and a logical IP-address, IPEXTRAD is displayed in between. For example:

```
pdisplay pnet,power275
```

```
1RB7I POWER275 SSL LINK POWER272 JOB 4096 HUS275 E
1RB7I PWD=H275 IPEXTRAD=009.155.155.175 IPADDR=HUS275
```

---

### Hardware Crypto Support

The VSE/ESA 2.7 hardware encryption assist support (referred to as Hardware Crypto support) requires a PCI Cryptographic Accelerator (PCICA) card or equivalent. The PCICA card is available on the IBM eServer **zSeries 800, 900, and 990** processors. It provides encryption assist support and can help to increase the throughput in a TCP/IP network using SSL (Secure Sockets Layer).

If VSE/ESA 2.7 runs under z/VM, z/VM 4.2 or higher is required.

Secure Sockets Layer (SSL) has become the dominant technique for enterprises to communicate securely with their customers via Internet browsers. SSL uses cryptography both for authentication of clients and servers, and for data confidentiality. SSL is a public key cryptography-based extension to TCP/IP networking.

VSE/ESA 2.7 supports the IBM PCI Cryptographic Accelerator (PCICA) card to provide encryption assist support for increased Secure Sockets Layer (SSL) throughput. The support is based on functions provided by *TCP/IP for VSE/ESA 1.5*.

The SSL support of *TCP/IP for VSE/ESA* was first introduced with VSE/ESA 2.6 and supported software encryption only. With VSE/ESA 2.7, SSL will transparently use PCICA cards if available. There will be no need to change any applications already using SSL. For example, existing applications that use the SSL such as the CICS Web Support (CWS) and the VSE e-business connectors will automatically benefit.

If the Hardware Crypto support is not available, *TCP/IP for VSE/ESA 1.5* will provide software encryption.

### Support Characteristics

The PCICA card supports the RSA encryption/decryption algorithm. It supports **RSA1024** and **RSA2048**. A key length of 512 is not directly supported by the hardware but is simulated by 1024 requests.

The PCICA card is plugged into an Adjunct Processor (AP) which has to be seen as an extension to the CPU. Once plugged into the system, the PCICA card is identified as follows:

- An eight-character serial number.
- A two-digit Adjunct Processor (AP) number.
- A CHPID number.

The CHPID number is not known and is not relevant to VSE/ESA, but is used for the hardware management of the PCICA card. A CHPID number assigned to a PCICA card is no longer available for normal CHPID use and cannot be used in an IOCDS definition. If there are CHPID definitions which conflict with the IOCDS, that is, if a CHPID is defined in the IOCDS with a number that matches the CHPID number assigned to the PCICA card because of plugging rules, a system power-on-reset will cause both, the already IOCDS-defined CHPID and the PCICA, not to come online.

Since the PCICA card is to be seen as an extension to the CPU, rather than as a new channel attached device, the PCICA card requires no configuring and thus

- no device type

- no ADD statement
- no IOCDs definition.

During system initialization (IPL), VSE/ESA senses the hardware and recognizes the Crypto support (PCICA card) if installed. The following messages are issued on the console by the Security Server partition (usually FB) which activates the Hardware Crypto support via startup job SECSERV:

**Crypto support available:**

```
FB 0011 // JOB SECSERV
        DATE 08/09/2002, CLOCK 13/16/38
FB 0011 ID (PARAMETERS SUPPRESSED)
FB 0095 1J014I FOUND A PCICA CARD AT DEVICE INDEX 2
FB 0095 1J005I HARDWARE CRYPTO ENVIRONMENT INITIALIZED SUCCESSFULLY.
FB 0095 1J006I USING CRYPTO DOMAIN 0
```

**Crypto support not available:**

```
FB 0011 // JOB SECSERV
        DATE 08/09/2002, CLOCK 13/16/38
FB 0011 ID (PARAMETERS SUPPRESSED)
FB 0095 1J017I CRYPTO HARDWARE NOT INSTALLED OR NOT DEFINED.
```

## Using the Crypto Support with a VSE/ESA Guest under z/VM

The Hardware Crypto support requires z/VM 4.2 or higher.

When VSE/ESA runs as a guest under z/VM, the Crypto support must be defined to the system in the *VM Directory Entry* with the following statement:

```
CRYPTO APVIRT
```

The CRYPTO APVIRT statement provides access to the Crypto hardware and allows to use Crypto specific instructions. The hardware is accessed via a domain ID. There are up to 16 domain IDs possible (0,1,...,15). Each domain ID is related to one user. The resulting limitation that only 16 users can use the Crypto hardware, is avoided through the APVIRT parameter which causes z/VM to dynamically assign domain IDs to different users. Only one virtual machine can use a domain at a time. If more than one virtual machine has a CRYPTO statement for a given domain, only the first virtual machine that logs on can use the domain.

z/VM provides special commands for the Crypto support as shown below:

1. The installed Crypto hardware can be queried with the following CP command:

```
Q CRYPTO
```

The command provides output similar to the one shown below:

```
q crypto
00: Processor 00 Crypto Unit 0 usable
00: Processor 01 Crypto Unit 1 usable
00: There is no user enabled for PKSC Modify
00: All users with directory authorization are enabled for key entry
00: Crypto Adjunct Processor is installed
```

2. With the following CP command you can check the currently assigned Crypto domain and device number of your VSE/ESA guest:

```
Q VIRTUAL CRYPTO
```

The command provides output similar to the one shown below:

```
q virtual crypto
00: No CAM or DAC Crypto Facilities defined
00: AP 0E Queue 08 shared
```



## Hardware Crypto

In the above example, Crypto domain 08 is used and device 0E is available for this particular VSE/ESA guest.

3. A domain can be dedicated to one particular guest. For example:

**CRYPTO DOMAIN 5**

4. With the appropriate authority, the settings can be queried and updated in CMS:

**DIRM CRYPTO**

z/VM assigns the AP (Adjunct Processor) queue numbers randomly, so it is normal for the guest to see a different queue number each time the guest is started. This is independent of the domain number. CP will not provide hardware Crypto support for third-level guests (VM2 as a second-level guest of VM1, with VSE/ESA as a guest on VM2). CP will not provide V=R guest survival support for the Crypto support.

Consult the corresponding z/VM manuals for further details about the z/VM Crypto support for guest systems.

## Using the Crypto Support and an External Security Manager

If you use an External Security Manager (and not the Basic Security Manager) the following implementation details of the Hardware Crypto support are important and must be observed.

The Hardware Crypto support is activated by the startup job SECSERV (Security Server) which is part of the Basic Security Manager and which runs in partition FB by default. If SECSERV is not started (because you are using an External Security Manager), the Hardware Crypto support is **not** available. However, the Hardware Crypto task can be started manually in any partition with a job stream such as the following:

```
* $$ JOB JNM=HWCRYPTO,DISP=D,CLASS=R
// JOB HWCRYPTO
// EXEC IJBCRYPT
/*
/&
* $$ E0J
```

To activate the Hardware Crypto support, proceed as follows:

1. Start the above job stream (or a similar one).
2. Shutdown TCP/IP and your TCP/IP applications (TCP/IP runs in partition F7 by default).
3. Restart TCP/IP and your TCP/IP applications.



---

## HiperSockets Support

VSE/ESA 2.7 supports high-speed TCP/IP communication among logical partitions (LPAR) and virtual machines using HiperSockets. The HiperSockets support is available on the IBM eServer **zSeries 800, 900, and 990** processors, and when running under z/VM 4.2 or higher also on **IBM Multiprise 3000** processors and on the **IBM S/390 Parallel Enterprise Servers G5 and G6**.

HiperSockets provide the fastest TCP/IP communication between operating systems running in the LPARs (Logical Partitions) or virtual machines of a processor which provides HiperSockets support. Like the OSA Express adapter support, the HiperSockets support is based on the QDIO (Queued Direct I/O) architecture.

z/VM 4.2 or higher supports virtual HiperSockets for use by guest operating systems which support HiperSockets such as VSE/ESA 2.7. This virtual HiperSockets environment for guest systems is available on IBM eServer **zSeries 800, 900, and 990** processors, but also when running on an **IBM Multiprise 3000** processor, or an **IBM S/390 Parallel Enterprise Server G5 or G6**.

### Support Overview

VSE/ESA supports up to four HiperSockets each of which acts like a TCP/IP network (LAN) within a processor. Each HiperSockets is defined by a HiperSockets channel path identifier (CHPID).

To use a HiperSockets connection, three HiperSockets I/O devices are required: a read control device, a write control device, and a data device for data exchange. This is basically the same as for an OSA Express adapter. Only the restriction to use an even/odd pair for the read/write control devices is dropped for HiperSockets. The sending and receiving I/O devices must be on the same CHPID. The processor maintains an IP address table for each HiperSockets. This table represents an emulated LAN. When a TCP/IP link is started, the link is registered in the table with its IP address and deleted when the TCP/IP link is closed.

Real LANs have a maximum frame size predefined by the architecture. With HiperSockets you can define the maximum frame size for each of the four possible HiperSockets yourself as shown under "IOCP Configuration."

### Invoking the Support

To use HiperSockets, the following tasks must be performed:

1. Configure IOCP.
2. Define HiperSockets I/O devices in VSE/ESA (IPL ADD statement).
3. Define HiperSockets I/O devices/links in TCP/IP (DEFINE LINK statement).

#### IOCP Configuration

Each HiperSockets requires the definition of a channel path identifier (CHPID). The following rules and characteristics apply:

- You can define four HiperSockets (IQD CHPIDs) per processor and share them among LPARs.
- The CHPID type for a HiperSockets definition is IQD.
- You can define up to 16 control units on each IQD CHPID.
- You can connect up to 256 devices to an IQD control unit.

## HiperSockets

- You can define the maximum frame size for IQD CHPIDs with the OS parameter.

**Relationship between OS parameter, frame size, and MTU** (Maximum Transmission Unit):

1. OS = 00 (default)  
Maximum frame size/MTU = 16KB/8KB
2. OS = 40  
Maximum frame size/MTU = 24KB/16KB
3. OS = 80  
Maximum frame size/MTU = 40KB/32KB
4. OS = C0  
Maximum frame size/MTU = 64KB/56KB

### IOCP Example:

```
CHPID PATH=(FC),SHARED,PARTITION=(...),TYPE=IQD,OS=40
CHPID PATH=(FD),SHARED,PARTITION=(...),TYPE=IQD
CNTLUNIT CUNUMBR=500,PATH=(FC),UNIT=IQD
CNTLUNIT CUNUMBR=600,PATH=(FD),UNIT=IQD
IODEVICE ADDRESS=(500,16),CUNUMBR=500,UNIT=IQD
IODEVICE ADDRESS=(600,3),CUNUMBR=600,UNIT=IQD
```

### HiperSockets Device Definitions in VSE/ESA

To use a HiperSockets connection, three HiperSockets devices are required (a read, a write, and a data device). These devices must be specified in the IOCP definition with channel type **IQD**. For VSE/ESA, the corresponding device type is **OSAX** (IPL ADD command). To distinguish HiperSockets devices from OSA Express devices a **mode of 1** must be specified as shown in the example below:

```
ADD 500:515,OSAX,1
ADD 600,OSAX,1
ADD 601,OSAX,1
ADD 602,OSAX,1
```

Note that all required devices must be added during IPL. The "Configure Hardware" dialog (Fastpath 241) supports the definition of HiperSockets devices; refer to "Configure Hardware Dialog (Fastpath 241)" on page 16 for details.

### HiperSockets Device and Link Definitions in TCP/IP

To use a HiperSockets connection, specify device and link information in the TCP/IP DEFINE LINK command as follows:

```
DEFINE LINK,ID=...,TYPE=OSAX,
    DEV=cuu1,                (or DEV=(cuu1,cuu2))
    DATAPATH=cuu3,
    IPADDR=addr,
    MTU=xxxx,                (default: as specified in the OS parameter)
    FRAGMENT={NO|YES}       (default: NO)
                             (YES not supported by HiperSockets)
```

These definitions are very similar to those required for OSA Express, except that:

1. HiperSockets do not require a PORTNAME (as does OSA Express).
2. The MTU size must not exceed the MTU size specified in the OS parameter (CHPID definition). The default MTU size is the size specified in the OS parameter (CHPID definition).

## Additional Information

### Partition resources required:

For each DEFINE LINK of an OSAX device, the TCP/IP partition requires

- Partition GETVIS (ANY) space as follows:  
About 400KB when defining OS=40 and about 1050KB when defining OS=C0.
- SETPFIX (ANY) space as follows:  
About 400KB when defining OS=40 and about 1050KB when defining OS=C0.

It may therefore be necessary to adjust the TCP/IP startup procedure accordingly.

### Error Messages:

In case of errors, message 0S39I is issued which includes two new reason codes for HiperSockets:

- REASON=x'0033'  
The HiperSockets device does not support HiperSockets features. This is most likely a hardware error.
- REASON=x'0034'  
The HiperSockets device could not be enabled. This is most likely a hardware error.

## Further Documentation

The following Redbook offers a broad description of the HiperSockets architecture and microcode function. It provides planning and implementation information, as well as setup examples:

*zSeries HiperSockets, SG24-6816*

You can order hardcopy Redbooks, as well as view, download, or search for Redbooks at the following Web site:

*[www.redbooks.ibm.com](http://www.redbooks.ibm.com)*

For HiperSockets support under VM, consult the corresponding VM documentation.

## Interactive Interface Enhancements

The following support was first included with VSE/ESA 2.7 but was not updated in the relevant manuals:

### Configure Hardware Dialog (Fastpath 241)

This dialog has been enhanced to define **HiperSockets devices**. HiperSockets devices are defined as OSAX devices with a Mode of 01.

```

ADM$HDWB          HARDWARE CONFIGURATION: UNIT ADDRESS LIST

OPTIONS: 2 = ALTER DEVICE TYPE CODE/MODE      3 = SELECT FOR FURTHER PROCESSING
         4 = LIST SIMILAR DEVICES             5 = DELETE A DEVICE

   OPT   ADDR  DEVICE  DEVICE-TYPE  DEVICE SPECIFICATION  DEVICE  DEF
          |    |      |      |              |              |      |
   -     307  24X80Q  3277              |              |      |
   -     308  24X80Q  3277              |              |      |
   -     309  24X80Q  3277              |              |      |
   -     30A  24X80Q  3277              |              |      |
   -     30B  24X80Q  3277              |              |      |
   -     30C  24X80Q  3277              |              |      |
   -     30D  24X80Q  3277              |              |      |
   -     30E  24X80Q  3277              |              |      |
   -     30F  24X80Q  3277              |              |      |
   -     2    877  OSAX   OSAX              |              |      |
POSITION NEAR ADDR == >
PF1=HELP      2=REDISPLAY  3=END          5=PROCESS  6=ADD ADDR
PF7=BACKWARD  8=FORWARD   9=PRINT
    
```

Figure 1. Selecting an OSAX Device

```

ADM$TYP1          HARDWARE CONFIGURATION: VSE DEVICE TYPE CODE

Enter the required data and press ENTER.

You can alter the VSE characteristics of device OSAX at address 877 .

VSE DEVICE TYPE CODE..... OSAX           Enter a valid VSE device type code.
                                           The corresponding device type
                                           is OSAX .
                                           A '?' will provide a selection list
                                           with all valid device types.

MODE..... 01                             Enter a device specification (mode).
                                           A '?' will provide a selection list
                                           with all valid device type modes.

PF1=HELP      2=REDISPLAY  3=END
    
```

Figure 2. Defining the MODE for a HiperSockets Device

### Dump Management Dialog (Fastpath 43)

This dialog has been enhanced to allow for the quick deletion of many dumps which is helpful if the dump library or a dump sublibrary is short on storage. If you press PF9 (9=DEL ALL) on the entry panel (PRB\$IDH1), you get the following panel displayed to define dumps for deletion:

```

PRB$IDHE                                DELETE DUMPS

Enter the required data and press ENTER.

TARGET LIBRARY NAME                      SYSDUMP

Enter the names of the sublibraries whose dumps should be deleted.
For valid sublibraries enter a "?".

SUBLIBRARIES .....  _  _  _  _  _  _

Enter the deletion period (date mm/dd/yy or number of days nnnn)
if you want to delete dumps of a specific time period.

DELETION PERIOD .....  _____

PF1=HELP      2=REDISPLAY  3=END

```

Figure 3. Selecting Dumps to be Deleted

**Notes:**

1. You can enter one or both selection criterias. All the dumps matching the criteria entered will be deleted.
2. If you enter a date for *Deletion Period*, all the dumps of this date and older will be deleted.
3. When you leave the *Storage Dump Management* dialog with PF5 (Process), the corresponding delete job will be created.

---

## SVA and CICS DSA Space Enhancements

Various system functions have been modified or their implementation has been changed to free space in the SVA-24 and in the CICS DSA area (of the CICS Transaction Server):

- The **Librarian** (LIBR) phase has been split into an SVA-24 and an SVA-31 part. This frees about 180KB in the SVA-24.
- The **User Status Record (USR)** of the Interactive Interface has been moved from CICS DSA below to above shared (including modules and mapsets). This frees about 2KB in the CICS DSA below area for each logged-on Interactive Interface user.

In addition, many Interactive Interface modules and mapsets have been moved to DSA above.

- The VSE/ICCF **terminal user area (TCTUA)** can be placed into the CICS DSA above area by specifying TCTUALOC=ANY. This frees about 255 Bytes for each logged-on Interactive Interface user.

---

## TotalStorage ESS Enhanced Support

The Large Volume of the IBM TotalStorage Enterprise Storage Server (ESS) has the following characteristics:

VSE/ESA device type: ECKD  
Number of cylinders: 32760  
Byte capacity per cylinder: 849960  
Number of tracks per cylinder: 15  
Byte capacity per track: 56664

The **VSE/VSAM** support is limited to the first **10017** cylinders which corresponds to the capacity of an IBM 3390 Model 9. This is a general restriction and applies to any volume larger than 10017 cylinders. Refer also to "VSE/VSAM Support of Large DASDs" on page 19.

Other programs and functions of VSE/ESA support the full capacity of a Large Volume:

- Non-VSE/VSAM access methods SAM and DAM (including IDCAMS Backup and Restore).
- ICKDSF (Device Support Facilities) program.
- VSE/Fast Copy program.
- VSE/POWER, Librarian, and all other VSE/ESA integrated applications.
- IPL commands DLA, DLF, and DPD.

## VSE/VSAM Support of Large DASDs

VSE/VSAM supports Large DASDs up to a capacity of **10017 cylinders** (150255 tracks). This limit corresponds to the capacity of an IBM 3390 Model 9.

If you try to define a VSE/VSAM catalog or space on a DASD volume that exceeds this limit of 10017 cylinders, you get the following message:

```
IDC0055I  VOLUME SPACE EXCEEDS MAXIMUM VSAM CAPABILITY. MAXIMUM WILL BE USED.
```

The VSE/VSAM support of Large DASDs increases the index allocation of a catalog for **all** DASD types (both Large DASD and “small” DASD):

- The index portion will be at least 4% of the primary catalog allocation.
- The index secondary allocation will have the same size as the index primary allocation.

Large DASD implementation does not change the mapping of free and used tracks of the space map in the catalog. However, using Large DASD the number of space map segments and used catalog records will increase. One catalog record can hold one segment of the space map which describes 3520 tracks. Currently, the maximum number of space map segments is 19 (this means, that 19 catalog records are required to map 65535 tracks on one disk).

For example, the IBM 3390 Model 9 has 10017 cylinders and 150255 tracks. The catalog will map the tracks of this disk device type within 43 catalog records.

## Making Use of the Support

If you are running with VSE/ESA 2.6, VSE/VSAM support of Large DASDs is available after you have installed the PTF UD52250 (APAR DY45977). For VSE/ESA 2.7 and later, VSE/VSAM support of Large DASDs is included and can be used immediately.

These IDCAMS DEFINE commands can be used for defining space allocation:

```
DEFINE MASTERCATALOG
DEFINE USERCATALOG
DEFINE SPACE
DEFINE CLUSTER UNIQUE
DEFINE ALTERNATEINDEX UNIQUE
```

The above commands internally check the disk capacity. They use either:

- Up to **65535 tracks** of the disk (the support before Large DASD) when:
  - the disk has up to 65535 tracks, **or**
  - the current catalog owns VSAM space on that disk defined before VSE/ESA 2.6.
- Up to **10017 cylinders** of the disk (the support introduced with Large DASD) when:
  - the disk has more than 65535 tracks, **and**
  - the current catalog does **not** own VSAM space on that disk that was defined before VSE/ESA 2.6.

For an IBM 3390-9 or other Large DASD, this means that either:

- VSAM space was already allocated on this disk for the current catalog from a previous VSE/ESA release. The disk will therefore not have Large DASD support, and will only be supported as a “64K-Track-Disk”.

## Large DASDs

- The VSAM space was not used by VSE/VSAM before VSE/ESA 2.6. The disk will therefore have Large DASD support, and a new flag bit in the Catalog Volume Record will indicate a "Large DASD".

In addition, for an IBM 3390-9 or other Large DASD:

- Where possible, allocations other than CYLINDERS (for example, TRACKS or RECORDS) will be translated internally to multiples of CYLINDERS. Or, if track allocation is required by VSE/VSAM for Large DASDs, allocations of tracks or records (for example) will be translated internally to multiples of tracks-per-cylinder. For example, a VSE/VSAM cluster with a primary (and secondary) allocation of one track will have a primary (and secondary) allocation of one cylinder.
- Track boundaries of extents will be rounded to cylinder boundaries.
- If a catalog resides on a Large DASD, the minimum allocation for the catalog is 5 cylinders (4 cylinders for the data component plus 1 cylinder for the index component).

## Migrating to Large DASDs Using IDCAMS Backup/ Restore

Most files that have been defined using a CI size of 512 *cannot* be migrated using IDCAMS Backup /Restore to a Large DASD device (this is due to internal restrictions). Backup/Restore is intended to transfer files with high performance, and is based on the CI Size.

Any file defined with IMBED option cannot be restored-to or defined-on a Large DASD.

If you have not applied APAR DY46154, you *cannot* IMPORT most files to a Large DASD device that were originally defined using a CI size of 512. Furthermore, on a Large DASD most files require a CI size of 1024.

If you wish to use files that have been defined with a CI-size of 512 on a Large DASD, you must follow these general steps:

1. Restore the files that have a CI-size of 512, to a previously-supported small DASD type. You use the IDCAMS RESTORE command to do so.
2. Export the files from the previously-supported small DASD type using the IDCAMS EXPORT command.
3. Import the files to a Large DASD, using the IDCAMS IMPORT command.

For further details about using the above IDCAMS commands, refer to the *VSE/VSAM Commands*, SC33-6731.

## Performance Considerations (KSDS Only)

The performance of KSDS access may change if the data control area size (data CA) changes. One index control interval (index CI) controls one data control area. The larger the data control area together with a large index control interval, the better the keyed access performance. This is because less index I/O operations are required for keyed-direct and keyed-sequential access. VSE/VSAM calculates the control area size from the smaller of the primary or secondary allocation. The minimum is one track, and the maximum is one cylinder (15 tracks).

**Note:** A control area size of one cylinder is recommended.



Where possible, a VSE/VSAM KSDS on a Large DASD will have a control area size of one cylinder. Primary and secondary allocations are rounded upward to cylinder multiples and to cylinder boundaries, even if they have been defined as TRACKS or as RECORDS. To also get a control area size of one cylinder for long keys (up to 255 bytes), VSE/VSAM calculates the minimum data control interval size (CI size) of a KSDS, and increases it where required. The following key lengths require the following minimum control interval sizes:

- A key length between 7 and 35 bytes requires at least 1024 bytes CI size.
- A key length between 36 and 55 bytes requires at least 2048 bytes CI size.
- A key length greater than 55 bytes requires at least 4096 bytes CI size.

### **BUFFERSPACE Parameter**

The BUFFERSPACE parameter could force a smaller data control-area size, and must have a size that is at least two data control-intervals plus one index control-interval. It is not recommended to be used at DEFINE CLUSTER. Large DASD support will never allow the BUFFERSPACE parameter to reduce the CA size.

## **Increased Size of the Catalog Index**

The index primary allocation of a catalog will be at least 4% of the primary catalog data allocation. The catalog index secondary allocation will have the same size as the index primary allocation.

## **Restrictions for VSE/VSAM Support of Large DASDs**

These are the restrictions that apply when using Large DASDs with VSE/VSAM:

- No Support for Imbedded Indices:
  - The definition of imbedded indices for catalogs, alternate indices, and clusters are not supported. If the keyword IMBED is used in existing IDCAMS DEFINE jobs, it will simply be ignored.
- The Catalog Default is NOIMBED:
  - For Large DASD support, the default value for DEFINE MASTERCATALOG and DEFINE USERCATALOG is NOIMBED.
  - Newly defined catalogs (MASTERCATALOG and USERCATALOG) will never have an imbedded index.
- No CRA on Large DASD:
  - There is no support for the CRA (Catalog Recovery Area) keyword RECOVERABLE on Large DASDs.
  - Existing recoverable catalogs and CRAs on “small” DASD will be accepted and supported.
  - New CRAs can be defined on “small” DASD, but no CRA can be defined on a Large DASD.
  - Recoverable catalogs cannot reside on a Large DASD and cannot own space on a Large DASD.

## **New or Changed Fields in LISTCAT Output**

The Large DASD support is integrated into the LISTCAT output as follows:

- The field DEVTYPE has the prefix “BIG-” for a Large DASD (for example, DEVTYPE-----BIG-3390). The prefix “BIG-” is used either in the Volume Group (DATA, INDEX) or in the Volume Entry.
- The field “TRACKS” in the Volume Group (DATA, INDEX) is replaced by “CYLINDERS” for a Large DASD.

## Large DASDs

- The field "SPACE-MAP" in the Volume Entry is replaced by "CYL-SPC-MAP", which indicates cylinder-mapping instead of track-mapping for a Large DASD.

---

## Information Moved From This Chapter

### Information Moved to the VSE/ESA Administration

The *VSE/ESA Administration* now contains this information related to VSE/ESA 2.7 that was originally contained in the *VSE/ESA Release Guide*:

- A description of a print function for creating status reports of the following Interactive Interface resources stored in the VSE Control File:
  - User profiles as displayed in Fastpath 211.
  - Selection profiles/panels as displayed in Fastpath 212.
  - Application profiles as displayed in Fastpath 213.
- A description of the *FlashCopy VSAM Catalog/Files* dialog.

## VSE/ESA 2.7 Items

---

## Chapter 2. VSE/ESA 2.6 Items

This chapter describes the items introduced with VSE/ESA 2.6 (including VSE/ESA 2.6.1 and VSE/ESA 2.6.2). These are the main items:

- “OSA Express Support”
- “Initial Installation Enhancements” on page 29
- “IPL Enhancement” on page 30
- “Interactive Interface Enhancements” on page 31
- “SDAID XPCC Trace” on page 33
- “SDAID GETVIS/FREEVIS Trace” on page 35
- “TERSE Utility” on page 38
- “Virtual Tape Support” on page 40
- “Information Moved From This Chapter” on page 53

### Related Section:

Chapter 4, “IXFP/SnapShot and FlashCopy Support,” on page 63

---

## OSA Express Support

The Open Systems Adapter (OSA) Express support is provided via the OSA Express adapter available for IBM S/390 **Parallel Enterprise Server G5** and **G6** and IBM eServer **zSeries 800** and **900** processors.

### Introduction

The OSA Express adapter is based on the QDIO (Queued Direct I/O) architecture and provides direct connectivity between VSE/ESA applications and other platforms on the attached network. The QDIO architecture allows a highly efficient data transfer since it eliminates the need for conventional I/O and interrupt processing. This results in accelerated TCP/IP data packet transmission. The OSA Express adapter consists of different features:

- Gigabit Ethernet
- Fast Ethernet
- ATM
- Token Ring

All features support the QDIO architecture. Additionally, the Fast Ethernet, ATM, and Token Ring feature can be configured to run either in QDIO or non-QDIO mode. To switch between the two modes, the *OSA/SF for VSE/ESA* program (which is part of VSE/ESA) is required.

The following table summarizes the OSA Express QDIO as well as the non-QDIO support. In a non-QDIO environment, either TCP/IP or SNA can be used as access method. As mentioned before, OSA/SF is needed if you plan to switch between the two modes.

*Table 2. Overview VSE/ESA OSA Express QDIO and non-QDIO Support*

Network	Mode	TCP/IP	SNA	OSA/SF required
Gigabit Ethernet	QDIO	yes	no	no

Table 2. Overview VSE/ESA OSA Express QDIO and non-QDIO Support (continued)

Network	Mode	TCP/IP	SNA	OSA/SF required
Fast Ethernet	QDIO	yes	no	no
Fast Ethernet	non-QDIO	yes	yes	yes
ATM (*)	QDIO	yes	no	no
ATM (*)	non-QDIO	yes	yes	yes
Token Ring	QDIO	yes	no	no
Token Ring	non-QDIO	yes	yes	yes

(\*) VSE/ESA supports ATM in LAN Emulation mode only.

## Invoking the Support

To use the OSA Express adapter, the following tasks must be performed:

1. Configuring IOCP
2. Defining OSA Express in VSE/ESA (IPL ADD statement)
3. Defining OSA Express in TCP/IP (DEFINE LINK statement).

### IOCP Configuration

OSA Express is identified in the S/390 I/O configuration by its channel path identifier (CHPID). The channel type for QDIO is OSD.

```
CHPID PATH=FC,TYPE=OSD
CNTLUNIT CUNUMBR=D00,UNIT=OSA,PATH=FC
IODEVICE ADDRESS=(D00,3),CUNUMBR=D00,UNIT=OSA
IODEVICE ADDRESS=(D03,3),CUNUMBR=D00,UNIT=OSA
```

In case of non-QDIO, the TYPE would be OSE instead of OSD.

**Note:** When defining devices for OSD CHPIDs, it is important to remember that there is a maximum of 240 subchannels per OSD CHPID. This means that the number of defined devices multiplied by the number of Logical Partitions (LPARs) that may access those devices must not exceed 240. For example, if we have a 5 LPAR configuration, the maximum number of OSD devices that can be defined per shared OSD CHPID is 48 (48 x 5 = 240). Using device candidate lists can increase the number of devices that can be defined providing LPARs are excluded. For example, if the CHPID or device candidate list is limited to 3 LPs, the maximum number of OSD devices is 80 (80 x 3 = 240). Note, that the candidate list should be specified explicitly, otherwise it defaults to all the LPARs defined on your RESOURCE statement in the IOCDS.

### OSA Express Definition in VSE/ESA

To access the OSA Express adapter in QDIO mode, you need three OSA Express devices (read, write, and datapath). You must specify these devices in the IOCP generation macro with device type OSA.

For VSE/ESA, the corresponding new device type **OSAX** has been introduced. It must be used for all the devices specified in the IOCP generation macro with channel type OSD and can be specified for VSE/ESA with the hardware configuration dialog. Refer also to “Configure Hardware (Fastpath 241)” on page 31. Following are examples of how to specify OSAX devices:

```
ADD D00:D02,OSAX
```

or

```
ADD D00,OSAX
ADD D01,OSAX
ADD D02,OSAX
```

All devices that are to be used later on must be added during IPL. If you want to specify a second DEFINE LINK within the same or a different TCP/IP partition, you have to add three more OSAX devices:

```
ADD D03:D05,OSAX
```

In case of non-QDIO, the device type for VSE/ESA must be OSA (as for the OSA-2 adapter). In non-QDIO mode, the OSA Express adapter behaves like an OSA-2 adapter and you have to specify only two devices of type OSA.

### OSA Express Definition in TCP/IP

To use the OSA Express adapter in QDIO mode, specify the TCP/IP DEFINE LINK command as follows:

```
DEFINE LINK,ID=...,TYPE=OSAX,
        DEV=cuu1 (or DEV=(cuu1,cuu2)),
        DATAPATH=cuu3,
        IPADDR=addr,
        MTU=max. 9000,          (default: 1492)
        PORTNAME=(8byte)name,
        FRAGMENT={NO|YES}     (default: NO)
                                (YES not supported by OSA Express adapter)
```

#### Explanations:

1. cuu1,cuu2 must be an even/odd pair. If cuu2 is omitted, cuu1 + 1 is taken as default.
2. An IP address can only be used once per *physical* OSA Express adapter, that is, a second DEFINE LINK for the same physical OSA Express adapter must contain a different IP address.
3. When you specify PORTNAME, you assign a name to the port of the OSA Express adapter. The first user who initializes the adapter determines the name of the port. Subsequent users within the same or different operating systems must use the same name. Starting with a certain microcode level, the OSA Express adapter requires the specification of PORTNAME. It is therefore recommended to always specify PORTNAME. See also "Example 1" and "Example 2" below.

If the DEFINE LINK fails with message 0S39I .... REASON=0032, the PORTNAME specified does not match the name specified initially.

#### Example 1:

```
DEFINE LINK,ID=...,TYPE=OSAX,
        DEV=(D00,D01),
        DATAPATH=D02,
        IPADDR=9.164.155.90,
        MTU=9000,
        PORTNAME=OSAXPORT
```

#### Example 2:

```
DEFINE LINK,ID=...,TYPE=OSAX,
        DEV=D04,
        DATAPATH=D03,
        IPADDR=9.164.155.99,
        MTU=1492,
        PORTNAME=OSAXPORT
```

### Further DEFINE LINK information:

- Several LINKs of type OSAX may be defined within one TCP/IP partition.
- The three OSA Express devices used for the DEFINE LINK must be unique within VSE/ESA.
- If running under VM, the three devices describing the OSAX link must be unique within VM.

### Additional TCP/IP considerations:

- If you want to change the properties of an OSAX LINK you have to do a DELETE/DEFINE LINK. The MODIFY command is not supported.
- The DEFINE ADAPTER is not needed.

### Partition resources required:

For each DEFINE LINK of an OSAX device, the TCP/IP partition requires 1050 KB partition GETVIS (ANY) space and 1050 KB for SETPFIX (ANY). It may therefore be necessary to adjust the TCP/IP startup procedure accordingly.

## Further Documentation

The following manuals provide additional information:

- For general overview information consult:  
"Chapter 4: Extended Networking Support" in the *VSE/ESA Planning* manual.
- For general planning information and OSA/SF consult:  
The manual *Planning for the S/390 Open Systems Adapter Feature*, GC23-3870, and the *VSE/ESA Open Systems Adapter Support Facility User's Guide*, SC28-1946.
- For OSA Express information consult:  
The manuals *S/390 OSA Express Customer's Guide and Reference*, SA22-7403, and *zSeries 900 OSA Express Customer's Guide and Reference*, SA22-7476.



---

## Initial Installation Enhancements

The enhancement is related to large processors that provide sufficient storage so that no page data set (NOPDS) is required. However, if VSE/ESA is installed on such a large processor, there was (up to VSE/ESA 2.5) no way to prevent the system from formatting the page data set even if it was never used. Only after initial installation was it possible to tailor VSE/ESA as a NOPDS system.

For this reason, the initial installation process has been modified for VSE/ESA 2.6 in order to check whether the processor storage size is sufficient to accommodate in real storage all the virtual storage as well as the real storage required by the system. The virtual storage size is the sum of the specified values for VSIZE and VIO.

If the processor storage available is sufficient, the DPD commands are ignored and no page data set is created. In addition, message 0I35I is issued:

```
0I35I  PROCESSOR STORAGE LARGER THAN VIRTUAL STORAGE - DPD COMMAND IGNORED
```

## IPL Enhancement

### Deleting Unexpired Secured System Files during IPL

If during IPL the page data set to be defined overlapped an existing secured page data set, up to VSE/ESA 2.5 the operator did not have the option to delete these files and reuse the space directly. The same applied to a secured label area. In order to reuse a secured page data set or a secured label area, the operator had to:

- Initialize the system with temporary extents for the page data set or the label area.
- Use a utility to delete the secured system files.
- Re-IPL the system with the original DPD or DLA specifications.

Starting with VSE/ESA 2.6, the IPL process been changed to allow the deletion of a secured page data set and to allocate a new page data set during IPL. The same applies to the label area. Message 0I99D is issued if such a condition exists:

```
0I99D system-file ON cuu: OVERLAP ON UNEXPIRED SECURED FILE
```

## Interactive Interface Enhancements

The following dialogs were new or have been enhanced:

- Enhanced dialog "Configure Hardware" (new device type OSAX) as described under "Configure Hardware (Fastpath 241)."
- Enhanced dialog "Compile Job Generation" (new parameter TEMPLATE) as described under "Compile Job Generation (Fastpath 51)" on page 32.

### TCP/IP Configuration (Fastpath 246)

The TCP/IP Configuration dialog has been enhanced for VSE/ESA 2.7. The dialog helps you configure your TCP/IP environment. After completing your definitions for the TCP/IP parameters shown in the panel below, you must press PF5 (PROCESS) to create a job stream which updates the related configuration members such as IPINIT00.L in system library PRD2.CONFIG. If no member exists in PRD2.CONFIG, the system default member IPINIT00 from PRD1.BASE is used. When pressing PF9 (VTAM), member TCPAPP00.B is updated.

```

CON$SEL                TCP/IP CONFIGURATION

Enter the required data and press ENTER.

To modify one or more of the following TCP/IP parameters,
place a 1 next to it.

-   SET           Modify SET IPADDR or SET MASK command
-   LINK          Modify DEFINE LINK command
-   ADAPTER       Modify DEFINE ADAPTER command
-   ROUTE         Modify DEFINE ROUTE command
-   TELNETD       Modify DEFINE TELNETD command

PF1=HELP      2=REDISPLAY  3=END      5=PROCESS
                9=VTAM
  
```

Figure 4. TCP/IP Configuration Dialog

Refer to the manual *TCP/IP for VSE/ESA IBM Program Setup and Supplementary Information* for a detailed description of the dialog.

### Configure Hardware (Fastpath 241)

When selecting 3 *Telecom. Devices (NCP, CTCA)* from the *Hardware Configuration: Device Group* panel, you get the panel SELECTION LIST: DEVICES as shown below. The panel offers a new device for selection: OSAX (Open Systems Adapter Express). Refer to "OSA Express Support" on page 25 for a detailed description of this support.

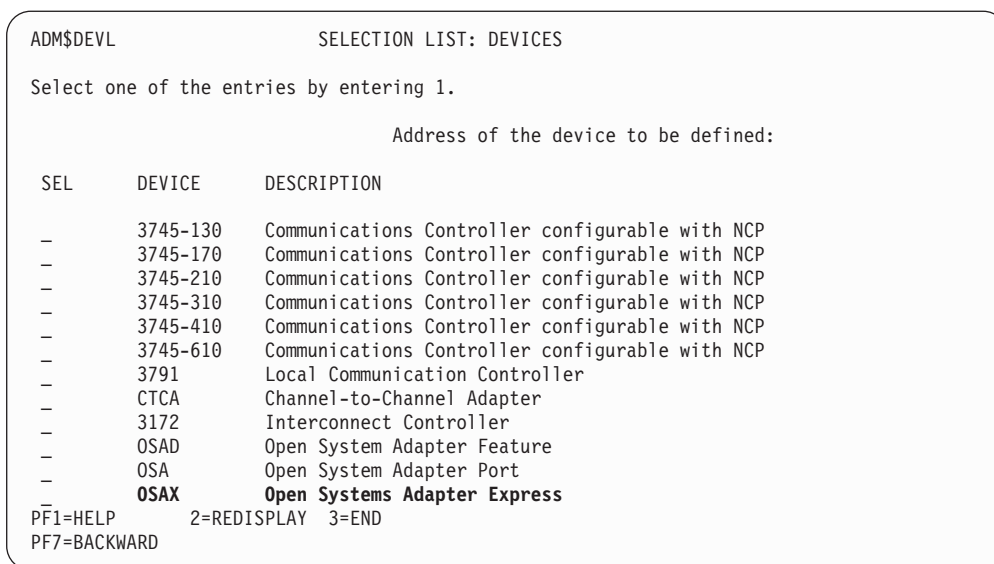

Figure 5. Selection Panel for OSAX

## Compile Job Generation (Fastpath 51)

The dialog *Compile Job Generation* described in the manual *VSE/ESA Programming and Workstation Guide* has been enhanced with the new parameter **TEMPLATE** as shown below. You reach this dialog by selecting option 8 (COMPILE) from the *Primary Library* or *Secondary Library* panel.

By specifying 1 (valid only for 3=Map Definition), you request the creation of a HTML template from a BMS map. This makes the compile output suitable for a Web browser environment. Maps of type HTML are stored in library PRD2.DFHDOC.

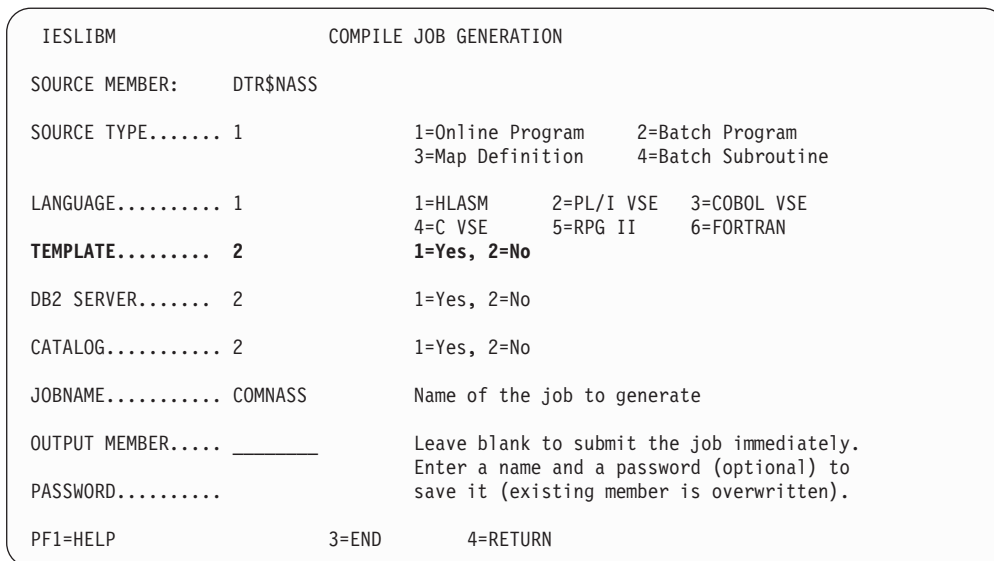

Figure 6. Compile Job Generation Panel

## SDAID XPCC Trace

VSE/ESA 2.6 provides a new SDAID XPCC trace which provides information about connections between different applications (Cross Partition Communication). The information will be gathered when the requested function has been processed and finished by the VSE cross partition communication routine.

### TRACE XPCC Command

The new TRACE XPCC command has been implemented into the current SDAID command list with the following parameters:

**TRACE XPCC** **APPL**=name **TOAPPL**=to-name **FUNC**=function **DIR**=direction  
**RC**=retcode **SUSR** compare-sign hexvalue **RUSR** compare-sign  
hexvalue **XPAREA**=from-partition **XPTOAREA**=to-partition  
**OUTPUT**=definitions **OPTION**=definitions

The command syntax is as follows:

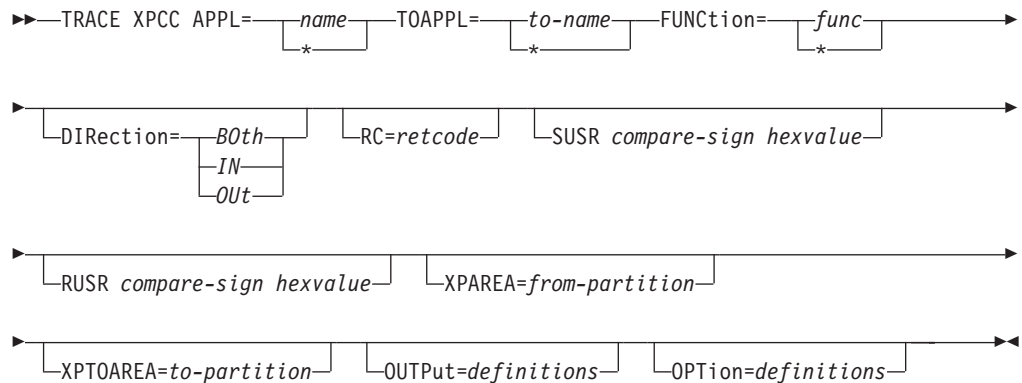

Parameter description:

**APPL=** Name of a dedicated application to be traced or an asterisk (\*) if all applications are to be traced.

**TOAPPL=** Name of a dedicated application to be traced or an asterisk (\*) if all applications are to be traced.

**Note:** For the naming convention and the meaning of **APPL** and **TOAPPL** refer to the description of macro XPCCB in the manual *VSE/ESA System Macros Reference*, SC33-6716.

**FUNC=** Up to six XPCC functions or an asterisk (\*) for all valid XPCC functions can be specified.

**Note:** For a list of valid XPCC functions, refer to the manual *VSE/ESA System Macros Reference*, SC33-6716.

**DIR=** **IN | OUT | BOTH**

Specifies the direction of tracing. OUT means that all outgoing requests of an application are to be traced. IN means that all incoming requests of an application are to be traced. BOTH means that all outgoing and incoming requests are to be traced. The default is BOTH.

**RC=** A one byte hexadecimal return code. If the parameter is set, only

such requests which finally finished with this particular RC are traced. If the parameter is omitted, the return code will not be checked.

**SUSR**

**compare-sign hexvalue**

The compare-sign can be one of the following:

- EQ** Check if **equal**
- NE** Check if **not equal**
- GT** Check if **greater than**
- LT** Check if **lower than**
- GE** Check if **greater or equal**
- LE** Check if **lower or equal**

The **hexvalue** identifies a field of 16 hexadecimal characters (0-9, A-F) reflecting field IJBXSUSR within macro XPCCB. If specified, the *hexvalue* will be compared using the specified *compare-sign* against field IJBXSUSR. If not all of the 16 hexadecimal characters (8 bytes) are to be compared, the not relevant hexadecimal characters have to be substituted by dots as shown in the example below. Only one block of consecutive bytes is allowed for comparison. If the parameter is omitted, no comparison takes place.

**Example:**

SUSR GE .....5F3

**RUSR**

**compare-sign hexvalue**

Same as for SUSR but field IJBXRUSR is used for comparison.

**XPAREA = Fn | BG | xn** (static or dynamic partition)

**XPTOAREA= Fn | BG | xn** (static or dynamic partition)

If XPAREA and XPTOAREA are specified, only those applications are traced which establish communication between XPAREA and XPTOAREA. If omitted, all partitions are traced.

**OUTPUT=** In addition to the current valid output definitions two new definitions have been added: **XPCCB** for printing the related XPCCB Control Block, and **XPDATABUFFER** for printing the related Databuffer or Databuffer Segments.

**OPTION=** All current valid option definitions.

## SDAID GETVIS/FREEVIS Trace

VSE/ESA 2.6 provides a new SDAID trace for tracking GETVIS and FREEVIS requests.

### TRACE GETVIS Command

There is no separate command for FREEVIS. The TRACE GETVIS command traces GETVIS requests as well as FREEVIS requests. The command syntax is as follows:

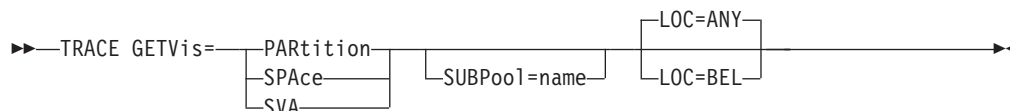

Parameter description:

<b>PAR</b>	Defines that a request for Virtual Storage is to be recorded, if its target is within a partition.
<b>SPA</b>	Defines that a request for Virtual Storage is to be recorded, if its target is within the Dynamic Space Getvis area of a dynamic partition.
<b>SVA</b>	Defines that a request for Virtual Storage is to be recorded, if its target is within the System Getvis area.
<b>SUBP</b>	Name of a Subpool for which Virtual Storage requests are to be traced. The default is all subpools.
<b>LOC=ANY</b>	Defines that a request for Virtual Storage is to be recorded, if its target is below or above the 16MB line. This is the default.
<b>LOC=BEL</b>	Defines that a request for Virtual Storage is to be recorded, if its target is below the 16MB line.

Note that the **AREA**, **OUTPUT**, and **OPTION** definitions can be used as described for other SDAID traces in the *VSE/ESA Diagnosis Tools* manual.

### Command Examples

1. TRACE GETVIS=SPA
2. TRACE GETVIS=SVA SUBPOOL=MYPOOL
3. TRACE GETVIS=PAR LOC=BEL

Explanation:

1. Traces all requests of Virtual Storage which are within the Dynamic Space Getvis area of a dynamic partition.
2. Traces all requests of Virtual Storage in the System Getvis area belonging to the Subpool MYPOOL.
3. Traces all requests of Virtual Storage which are within a partition below the 16MB line (24 bit).

## Initializing the Trace with Procedure SDGETV

The procedure SDGETV initializes traces for all types of Virtual Storage requests. The command syntax is as follows:



The parameters are the same as those described before for the GETVIS/FREEVIS command.

Note that the **AREA**, **OUTPUT**, and **OPTION** definitions can be used as described for other SDAID traces in the *VSE/ESA Diagnosis Tools* manual.

### Defaults Set in the Procedure

GETVIS=SVA is active if you omit GETVIS=, and LOC=ANY is active if you omit LOC=.

### EXEC Statement Example

```
// EXEC PROC=SDGETV,GETVIS=PAR,AREA=BG,ADDRESS=0:*,TAPE=280
```

The trace invoked has the following characteristics:

- Trace type: GETVIS
- Traced tasks: All tasks
- Target of traced events: Partition Getvis Area
- Area for which events are collected: BG Partition
- Output destination: Tape with device address 280

## Trace Output Example

The GETVIS/FREEVIS trace provides information concerning requests to obtain or release Virtual Storage via SVC 3D or SVC 3E, or because of an internal GETVIS call via BRANCH and LINK.

In contrast to a simple trace of the SVC's 3D and 3E which only shows the existence of these SVC's at the point of invocation, this new trace records the result of a particular Virtual Storage request after it has been evaluated by the VSE/ESA GETVIS/FREEVIS routines.



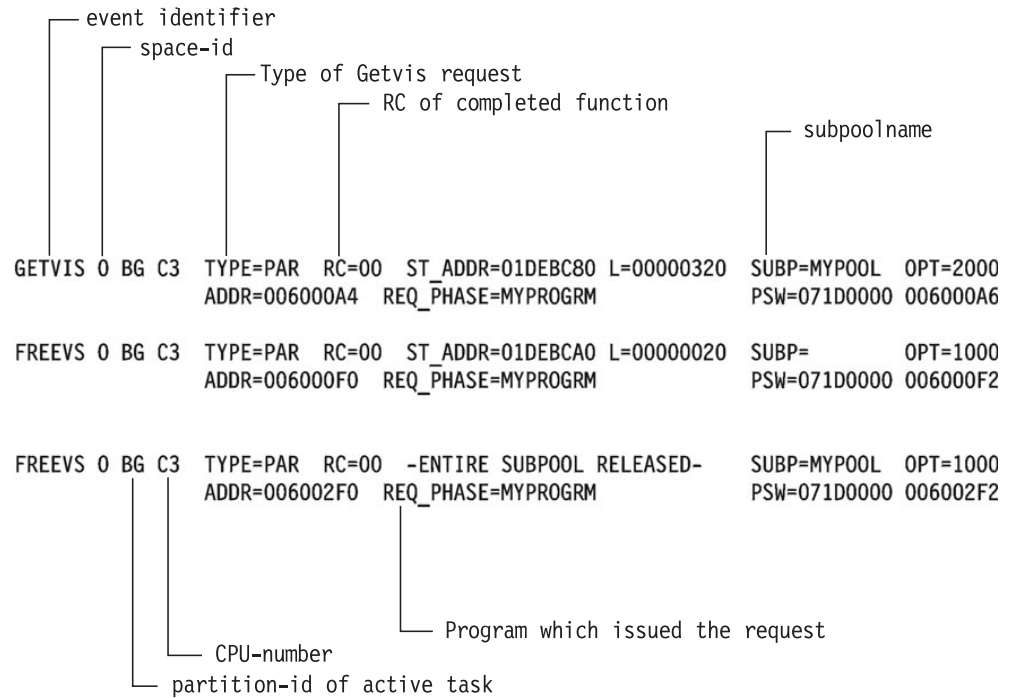

### Printer Defined as Output Destination

Since SDAID is capable to run in a **multiprocessor** environment, the selected printer is exclusively used by SDAID. An error message will be issued if this printer is already assigned to another partition.

### Multiprocessor Capability

All SDAID traces, including the GETVIS/FREEVIS trace, are capable to run in a multiprocessor environment. In the output, this is reflected by the CPU-number (C3 in the example).

---

**TERSE Utility**

TERSE is a Cross-Platform Compression Utility (Copyright (C) Advantis, 1994).

**Note:** This TERSE utility only works for **VSE Library members** that are **not** of type DUMP or PHASE.

TERSE requires LE/VSE or at least the VSE C Language Run-Time Support. You invoke the VSE/ESA implementation of TERSE with:

```
// EXEC TERSE,PARM='...'
```

Parameters are passed by the PARM='...' statement and can be:

```
switches  
sourcefile  
targetfile
```

Parameters are not case sensitive. Invoking TERSE without parameters causes a help message to be printed on SYSLIST.

All TERSE utility messages are printed on SYSLST. The messages do not have a message number.

Some of the more important switches which you may specify are:

```
-b .... binary ..... binary mode (text mode is default)  
-h .... help ..... display extended help documentation  
-s .... statistics .... display statistical information  
-f .... fixed ..... fixed-length records  
-e .... ebcdic ..... host ebcdic code page  
-a .... ascii ..... pc ascii code page  
-l .... language ..... country code for code page pair
```

The target file is assumed to be the same as the source file unless another target file is explicitly specified. The appropriate function (compression or decompression) will be selected automatically. The autoselection logic can also be disabled if necessary. Read the “-h” extended help information to learn how. Extended help also discusses file transfer procedures which you must follow to successfully exchange compressed files with the host.

Invoking TERSE with parameter -h (or -help) prints help information:

```
// EXEC TERSE,PARM='-H'
```

The following switches may be specified to override the autoselection logic which normally determines if a file should be compressed or decompressed by examining the special tersed file header:

```
-c .... compress ..... compress the source file  
-d .... decompress .... decompress the source file
```

Under rare circumstances the autoselection logic may assume that an uncompressed file has already been compressed and try to decompress it. In this case it would be necessary to specify the “-c” switch to force compression. In the same fashion, the “-d” switch can force decompression for files which are incorrectly considered by the autoselection logic to be decompressed already.

The following switch is provided to assist in situations when unexpected or inexplicable results occur:

```
-x .... examine ..... display tersed file header data
```

The “-x” switch will cause the autoselection logic to display the contents of the tersed file header without actually doing any data conversion.

To convert a file “in place” (without creating an output file with another file name) just omit the target filename, or specify the same filename for both the source and target files. In either case the new file will replace the original.

When running the TERSE program from a batch file or other environment where extraneous output is undesired, you can specify the “-q” switch:

```
-q .... quiet ..... suppress all boilerplate text
```

The “-q” switch will be ignored if the “-s” switch has also been specified.

File names are specified as follows:

```
DD:PRIMARY.SYSA(MYFILE.TXT)
```

Following is an example of how to invoke the TERSE utility to terse a file (library member):

```
// EXEC TERSE,PARM='DD:PRIMARY.FRAN(INPUT.TXT) DD:PRIMARY.FRAN(OUTPUT.TXT)'
```

This causes the TERSE utility to use INPUT.TXT as input member and terse it to OUTPUT.TXT.

The TERSE utility detects automatically if a given input file is tersed or not. If the input file is not tersed, it will be tersed and stored in the output file. If the input file is tersed it will be untersted and stored in the output file.

The output file can be omitted. In this case the input file is read, tersed/untersted and stored with the same name.

**Note:** The terse/unterse process uses a temporary file which has the same location as the output file.

---

### Virtual Tape Support

In VSE/ESA, a virtual tape is a file containing a tape image. A virtual tape can be a VSE/VSAM file on the VSE/ESA host or a remote file located on a server.

#### VSE/VSAM or Remote Virtual Tape

In VSE/ESA, a virtual tape is a file (or dataset) containing a tape image. A virtual tape can be:

- A VSE/VSAM **ESDS** file on the VSE/ESA host side.
- A **remote** file on the server side; for example, a Linux, UNIX, or Windows file. To access such a remote virtual tape, a **TCP/IP** connection is required between VSE/ESA and the remote system.

#### Defining the Tape Device

A virtual tape must be added to the system like a physical tape (unit). It must have at least one **cuu** address. For example:

```
ADD cuu,3480
```

The Virtual Tape Support is available for tape devices with a device type code of **3480**, **3490**, or **3490E**.

**Note:** It is recommended to select for virtual tapes unique *cuu* numbers that are not used by physical tape units in order to avoid any tape handling or tape operation problems.

#### VTAPE Command

You start and stop the Virtual Tape Support with the **VTAPE START** and the **VTAPE STOP** command. Examples are shown in the following sections and a detailed description of the command syntax and the command parameters is provided under “The VTAPE Command/Statement” on page 51.

The commands can be issued from both, a static or a dynamic partition, and also from a REXX procedure via the JCL host command environment (ADDRESS JCL).

#### Functional Components of the Virtual Tape Support

The Virtual Tape Support consists of three functional components:

- **Virtual Tape Simulator**

The Virtual Tape Simulator is part of VSE/ESA and ready for use after VSE/ESA installation. It controls virtual tape processing independent of where the virtual tape is located (VSE/VSAM or remote). It receives any incoming requests and forwards them to the Virtual Tape Data Handler for processing. It finally provides status information about the function performed.

**Note:** For each virtual tape **cuu**, the Virtual Tape Simulator acquires approximately 1MB of PFIxed system storage (real) as buffer space. This may cause problems when running virtual tapes in parallel and the real storage available is not > 16MB (under z/VM, for example).

- **Virtual Tape Data Handler**

The Virtual Tape Data Handler is part of VSE/ESA and ready for startup after VSE/ESA installation. It is required for handling the read or write access to any virtual tape: VSE/VSAM virtual tapes or remote virtual tapes via TCP/IP. When the Virtual Tape Support is activated (VTAPE START command or statement),

the Virtual Tape Data Handler is loaded into a dynamic partition, which is the default, or into a static partition (refer also to “Startup of the Virtual Tape Data Handler”). When the Virtual Tape Support is deactivated, the partition is released again.

- **Virtual Tape Server**

The Virtual Tape Server is required for **remote virtual tapes only**. It is the workstation counterpart to the Virtual Tape Data Handler on the VSE/ESA side with which it communicates via TCP/IP. The Virtual Tape Server must be installed on a workstation with a Java platform (refer also to “Installing the Virtual Tape Server” on page 42).

## Startup of the Virtual Tape Data Handler

This section provides some background information on the startup of the Virtual Tape Data Handler. The Virtual Tape Data Handler is started automatically when the first VTAPE START command or statement is submitted. This causes the startup job TAPESRVR, stored in the VSE/POWER reader queue, to be released. By default, the Virtual Tape Data Handler runs in a **dynamic partition of class R**.

The Virtual Tape Data Handler requires the C-Runtime Library.

The startup job TAPESRVR is placed in the VSE/POWER reader queue either

- during initial installation of VSE/ESA, or
- during a cold startup of VSE/ESA.

VSE/ESA provides in VSE/ICCF library 59 skeleton SKVTASTJ which includes startup job TAPESRVR (Figure 7).

```
* $$ JOB JNM=CATSTVTA,DISP=D,CLASS=0
// JOB CATSTVTA          CATALOG TAPESRVR AND LDVTA, LOAD TAPESRVR
// EXEC LIBR,PARM='MSHP'
ACC S=IJSYSRS.SYSLIB
CATALOG TAPESRVR.Z      REPLACE=YES
$$$$ JOB JNM=TAPESRVR,DISP=L,CLASS=R,LOG=NO
$$$$ LST CLASS=A,DISP=D,PURGE=0004
// JOB TAPESRVR START UP VSE TAPE SERVER
// LIBDEF *,SEARCH=(PRD2.CONFIG,PRD1.BASE,PRD2.SCEEBASE)
// ID USER=VCSRV
// EXEC $VTMAIN,SIZE=$VTMAIN
$$/*
$$/&
$$$$ EOJ
/+
CATALOG LDVTA.PROC      REPLACE=YES DATA=YES
// EXEC DTRIINIT
      LOAD TAPESRVR.Z
/*
/+
/*
// EXEC PROC=LDVTA      TO LOAD TAPE SERVER INTO RDR QUEUE
/&
* $$ EOJ
```

Figure 7. Skeleton SKVTASTJ (for Starting the Virtual Tape Data Handler)

The skeleton does the following:

1. Catalogs startup job as TAPESRVR.Z into IJSYSRS.SYSLIB.

## Virtual Tape

2. Catalogs procedure LDVTA which loads TAPESRVR.Z into the reader queue via DTRIINIT.
3. Executes LDVTA.PROC. If you do not want to load the startup job immediately into the active reader queue, delete the line // EXEC PROC=LDVTA.

The job stream loads the Virtual Tape Data Handler into a dynamic partition of class R which occupies 8 MB. 8 MB is the minimum required.

If you create a new TAPESRVR job, delete the old one in the VSE/POWER reader queue to ensure that the new one is released by the VTAPE START command. Note that the job name TAPESRVR must not be changed.

## Installing the Virtual Tape Server

**Note:** The Virtual Tape Server is required for **Remote Virtual Tapes** only.

It must be installed on a workstation with a Java platform. The following steps are required:

- Obtain a copy of the Virtual Tape Server.
- Perform the Virtual Tape Server installation.

In addition, support to uninstall the Virtual Tape Server is available.

The Virtual Tape Server is part of VSE/ESA 2.6 and consists of one file stored in PRD1.BASE: **vtapesrv.w**.

### Obtaining a Copy of the Virtual Tape Server

Before you begin, you must already have installed the Java Development Kit (JDK) 1.2.2 or higher on the workstation where you plan to install the Virtual Tape Server. You can download it from the Internet via the following URL:

**<http://www.ibm.com/java/jdk/download/index.html>**

To obtain a copy of the Virtual Tape Server, get it either from the Internet or from the VSE/ESA library PRD1.BASE.

- To obtain the Virtual Tape Server from the Internet, enter the following URL and download the file **install.class** to the directory where you want to install the Virtual Tape Server.

**<http://www-1.ibm.com/servers/eserver/zseries/os/vse/support/vseconn/vse26/vtape.htm>**

- To obtain the Virtual Tape Server from the VSE/ESA library PRD1.BASE, use the FTP (file transfer program) utility of TCP/IP for VSE/ESA to download **vtapesrv.w** to the directory where you want to install the Virtual Tape Server.

#### Notes:

1. You must download **vtapesrv.w** in *binary*.
2. Make sure that Unix mode is *turned off*. Otherwise **vtapesrv.w** will be downloaded in ASCII mode, even when you specify *binary*. *UNIX mode* is one parameter of your VSE FTP daemon. Some FTP clients might *force* UNIX mode to be turned on. The example below shows how a successful transfer of **vtapesrv.w** was made using a (command line) FTP client. The place where the UNIX mode is set, is shown as bold.

```
c:\temp>ftp 10.10.1.2 (this is the IP address of the VSE/ESA system)
Connected to 10.10.1.2
220-TCP/IP for VSE -- Version 01.04.00 -- FTP Daemon
    Copyright (c) 1995,2000 Connectivity Systems Incorporated
220 Service ready for new user.
```

```

User (10.10.1.2:(none)): sysa
331 User name okay, need password.
Password:
230 User logged in, proceed.
ftp> cd prd1
250 Requested file action okay, completed.
ftp> cd base
250 Requested file action okay, completed.
ftp> binary
200 Command okay.
ftp> get vtapesrv.w
200 Command okay.
150-File: PRD1.BASE.VTAPESRV.W
      Type: Binary Recfm: FB Lrecl:   80 Blksize:   80
      CC=ON  UNIX=OFF RECLF=OFF TRCC=OFF CRLF=ON NAT=NO
150 File status okay; about to open data connection
226-Bytes sent:      4,756,400
      Records sent:      59,455
      Transfer Seconds:   16.52 (   290K/Sec)
      File I/O Seconds:   3.94 ( 1,548K/Sec)
226 Closing data connection.
4756400 bytes received in 17,12 seconds (277,91 Kbytes/sec)
ftp> bye
221 Service closing control connection.
c:\temp>ren vtapesrv.w install.class

```

## Performing the Virtual Tape Server Installation

To perform the installation of the Virtual Tape Server, you must:

1. Open a Command Prompt and change to the directory into which you have downloaded the **install.class** file.
2. If you have downloaded the file from the VSE/ESA host, rename **vtapesrv.w** to **install.class**.
3. Type **java install** and press **Enter**. The installation process now begins, and you are guided through various installation menus. If you receive a message such as "java.lang.NoClassDefFoundError: install", then your local **classpath** environment may not be set correctly. Enter:
 

```
set classpath=.;%classpath%
```

For further details on how to correct such a problem, refer to "Setting the classpath Environment Variable" in the *VSE/ESA e-business Connectors User's Guide*.

4. The *Select Components to Install* window (Figure 8 on page 44) provides you with a choice:
  - Select *Virtual Tape Server* to install the Java code of the server.
  - Select *Online Documentation* for online help and support information.



Figure 8. Selecting the Components of the Virtual Tape Server

After making your selection, click **Next**.

5. Select the directory you want to use. The default is `c:\vtape\`.

After making your selection, click **Finish** to complete the installation..

**Note:** Desktop icons are created for Windows NT, Windows 2000, and OS/2.

**Uninstalling the Virtual Tape Server:** If there is a need to uninstall the Virtual Tape Server from your workstation, three methods are available:

- Using the **Uninstall** option provided by the Virtual Tape Server. From the Windows **Start**, select **Programs — Virtual Tape — Uninstall**, and the *Uninstall* window is displayed. Then select the components you wish to uninstall. If you select **Remove All Components**, after all components have been uninstalled, the icons on your desktop will also be removed.

**Note:** For Windows, it is recommended to use this method.

- Running the batch uninstall program **juninst** manually. Using this method, you can *only uninstall all components*. Your desktop icons will also be removed. Under Windows NT, this uninstall batch file is contained in the directory `\WINNT\Profiles...`
- A third method is available under Windows NT only. From the Windows NT **Start**, select **Settings — Control Panel — Add/Remove Programs**. Now you can select **juninst.bat** and click **Install/Uninstall** to remove the Virtual Tape Server.

### Starting the Virtual Tape Server

To start the Virtual Tape Server you may either click on the icon **Start Server** in the Programm Group **Virtual Tape** (available on Windows only), or execute one of the script files **run.bat** or **run.cmd** (Windows) or **run.sh** (Linux or UNIX). The run script adds the *VirtualTape.jar* to the classpath and starts the Virtual Tape Server:

```
set classpath=.;VirtualTape.jar;%classpath%
java com.ibm.vse.vtape.VirtualTapeServer
```



## Important Considerations When Using Virtual Tapes

In general, the Virtual Tape Support included in VSE/ESA 2.6 is intended to be transparent to applications, and to provide customers with the ability to read from or write to a virtual tape in the same way as if it were a physical tape. For technical and performance reasons, the full range of the capabilities of a physical tape has not been implemented and there are a number of restrictions outlined in this section. This section also provides and points to planning information to be considered before you start using virtual tapes at your installation.

The following **RESTRICTIONS** apply for virtual tapes:

- The SDAID trace program does not support virtual tapes.
- The DITTO/ESA for VSE program does not support the ERASE TAPE function for virtual tapes.
- Multivolume tape files and alternate tapes (ALT option of the ASSGN statement) are not supported for virtual tapes.

As for real tapes, it is recommended **not** to run virtual tape job streams in VSE/ICCF interactive partitions.

When using virtual tapes, you should be aware of the following virtual tape **Requirements and Characteristics**:

- The file you need for containing the virtual tape is created automatically in case of a remote virtual tape.  
For a VSE/VSAM virtual tape, however, you must create the file yourself. Refer to “VSE/VSAM ESDS File Definition (Skeleton SKVTAPE)” on page 46 for details.
- A remote virtual tape behaves like a physical tape with regard to reading/writing. A VSE/VSAM virtual tape, however, behaves differently in case of writing. Refer to “Writing to VSE/VSAM Virtual Tapes” on page 47 for details.

For the latest information on supported functions and programs, operating characteristics, and possible restrictions refer also to the VSE/ESA home page (Service and Support page) at:

<http://www-1.ibm.com/servers/eserver/zseries/os/vse/support/support.htm>

## Working with VSE/VSAM Virtual Tapes

To work with VSE/VSAM virtual tapes, you must first define the VSE/VSAM ESDS file which is to contain the virtual tape. This can be done either via the dialog *Define a New File* (Fastpath 222), or via the VSE/VSAM IDCAMS job stream provided in skeleton SKVTAPE available in VSE/ICCF library 59.

You can then use the new JCL command VTAPE to open the VSE/VSAM file as a virtual tape which can be accessed via the *cuu* specified. For example:

```
VTAPE START,UNIT=cuu,LOC=VSAM,FILE='vsamfilename',SCRATCH
```

In the example, the SCRATCH parameter is optional and causes the virtual tape to be cleared before new data is written to it.

```
VTAPE STOP,UNIT=cuu
```

closes the virtual tape file and drops the association between the tape unit *cuu* and the virtual tape file. If this was the only active VTAPE session, the VSE/ESA partition in which the Virtual Tape Data Handler is running is released after 30 seconds.

### VSE/VSAM ESDS File Definition (Skeleton SKVTAPE)

Skeleton SKVTAPE creates a VSE/VSAM ESDS file that is to contain a virtual tape. Figure 9 shows the skeleton.

```
* $$ JOB JNM=SKVTAPE,CLASS=0,DISP=D
// JOB SKVTAPE      CREATE VIRTUAL TAPE FILE
// EXEC IDCAMS,SIZE=AUTO
  DELETE (VSE.VTAPE.FILE) PURGE CL -
    CATALOG(VSESP.USER.CATALOG)
  DEFINE CLUSTER (NAME(VSE.VTAPE.FILE) -
    RECORDS (1000 1000) -
    TO (99366) -
    REUSE -
    NONINDEXED -
    SHAREOPTIONS (1) -
    SPANNED -
    RECORDSIZE (32758 32758) -
    VOLUMES (-V001-) -
    DATA (NAME(VSE.VTAPE.FILE.@D@) -
    CISZ (32768)) -
    CATALOG (VSESP.USER.CATALOG)
  IF LASTCC NE 0 THEN CANCEL JOB
/*
// OPTION STDLABEL=DELETE
VTAPE1
/*
// OPTION STDLABEL=ADD
// DLBL VTAPE1,'VSE.VTAPE.FILE',99/366,VSAM,CAT=VSESPUC
/*
// EXEC IESVCLUP,SIZE=AUTO          ADD LABEL TO STD LABUP PROC
D                                     VTAPE1
A VSE.VTAPE.FILE                     VTAPE1 VSESPUC
/*
/&
* $$ EOJ
```

Figure 9. Skeleton SKVTAPE

#### Explanations to skeleton SKVTAPE:

- V001-** This variable defines the volume on which the VSE/VSAM virtual tape file is located. The VSAM space is part of the VSE/VSAM user catalog VSESPUC (VSESP.USER.CATALOG).
- RECORDS** The number of RECORDS depends on the amount of data the virtual tape is to contain. The definition provided in SKVTAPE results in a file size of about 32MB. If this size does not meet your requirements, modify the definitions in SKVTAPE accordingly.
- REUSE** REUSE allows repeated writing to a virtual tape from the beginning. When specifying the SCRATCH parameter in the VTAPE START command, the tape is cleared before new data is written to it. Without the SCRATCH parameter, existing data is overwritten. Refer also to “Writing to VSE/VSAM Virtual Tapes” on page 47.

NOREUSE is for creating a new and empty file for writing data to it once; for backup, for example. NOREUSE together with SCRATCH is invalid and causes an error message.

#### SHAREOPTIONS

SHAREOPTIONS (1) allows multiple READ operations or one WRITE operation to be active. It is recommended not to change the setting of the share option. Refer to “File Sharing” for further details.

#### RECORDSIZE

The value for the RECORDSIZE parameter is the CISZ value minus 10 bytes (CISZ minus 20 bytes in case of a compressed cluster).

#### CISZ

The recommended value for the Control Interval Size is 32 KB; it should not be smaller than 8 KB.

**File Size:** The 4GB limit for VSE/VSAM files applies also for VSE/VSAM virtual tape files.

**File Name:** In the skeleton, **VTAPE1** in the DLBL statement is the filename to be used in the VTAPE START command.

**File Sharing:** Whatever is defined in SHAREOPTIONS, the Virtual Tape Data Handler accepts only single WRITE **or** multiple READ access to a VSE/VSAM virtual tape from a single VSE/ESA system. This corresponds to SHAREOPTIONS (1). If you want to access a VSE/VSAM virtual tape from more than one VSE/ESA system, use SHAREOPTIONS (1) which allows single WRITE **or** multiple READ access only. SHAREOPTIONS (1) avoids unpredictable results in case of multiple system access.

### Writing to VSE/VSAM Virtual Tapes

WRITE can only start at the beginning of a VSE/VSAM virtual tape. No rewrite or overwrite of existing data is possible except from the beginning a tape. For writing to a VSE/VSAM virtual tape more than once, the file definition (skeleton SKVTAPE) must include the REUSE parameter. Once a VTAPE STOP command has been issued, the remaining buffer contents is written to tape, the tape is closed, and an end-of-volume (EOV) indicator is written. This means no further data can be appended (added) to this particular virtual tape.

There are three ways of writing to a VSE/VSAM virtual tape:

1. The VSE/VSAM file is defined with REUSE.  
During OPEN processing the tape is positioned to its beginning before a WRITE operation starts. Existing data is overwritten.
2. The VSE/VSAM file is defined with REUSE and VTAPE START includes the SCRATCH parameter.  
SCRATCH causes the tape to be cleared before WRITE starts at the beginning of the tape.
3. The VSE/VSAM file is defined with NOREUSE.  
You can write to the tape only once (for backup, for example).  
NOREUSE with SCRATCH is invalid and causes an error.

### Working with Remote Virtual Tapes

To access a remote virtual tape, a TCP/IP connection must be established between VSE/ESA and the remote workstation with the **Virtual Tape Server** installed. You start the VTAPE support for a remote virtual tape with a VTAPE command such as the following:

```
VTAPE START,UNIT=cuu,LOC=ipaddress:portnumber,FILE='filename'
```

The *ipaddress* identifies the Virtual Tape Server workstation on which the remote virtual tape file is located (a Linux, UNIX, or Windows file, for example). *portnumber* is the TCP/IP portnumber to be used for the connection. If the virtual tape file does not exist yet, the command automatically causes the creation of the required file (Linux, UNIX, or Windows) using the *filename* specified. The VTAPE command

```
VTAPE STOP,UNIT=cuu
```

drops the association between the tape unit *cuu* and the remote virtual tape file. If this was the only active VTAPE session, the VSE/ESA partition in which the Virtual Tape Data Handler is running is released after 30 seconds.

#### File Names and other Considerations

If the required Linux, UNIX, or Windows file for a remote virtual tape does not exist yet, it is automatically created when submitting the corresponding VTAPE START command. When assigning file names you must observe certain rules and characteristics as outlined below.

**Linux and UNIX Considerations:** Linux and UNIX are case sensitive but job streams created on the VSE/ESA host (dialogs of the Interactive Interface) are in capital letters. It may be therefore necessary to edit such job streams to adapt the *filename* to the Linux or UNIX conventions.

**Windows Considerations:** Windows file names may contain blanks, therefore the *filename* must be enclosed in quotes. A quote within a *filename* must be coded as two single quotes; for example:

```
FILE='D:\John's\Virtual Tapes\vt001401.001'
```

Windows file names can have more than 100 characters in length. Since the limit for remote files is 100 characters, you may specify *FILE='filename'* twice or even three times. The *filename* is concatenated in storage, thus allowing for a file name

length of 200 or even 300. The following example is equivalent to the previous example:

```
FILE='D:',FILE='\John'\s\Virtual Tapes\',FILE='vt001401.001'
```

### Further Documentation

The workstation with the Virtual Tape Server installed provides the document **vtape.html**. It includes further details about remote virtual tapes and the related environment. You reach the document by selecting from the Start Menu first *Virtual Tape*, and then *Help*.

## Examples of Using Virtual Tapes

### Backing Up and Restoring Data

Backup functions often produce tape output. Thus you may consider whether virtual tapes are an alternative for such tasks in your data processing environment. For temporary data or short term backups in a VSE/ESA environment, for example, VSE/VSAM virtual tapes avoid the overhead of mounting and handling physical tapes.

Following is a backup example using a remote virtual tape. Data on a remote virtual tape can be saved on CD-ROM for archiving or for distribution. In the example, a VSE library backup and a later restore is assumed.

1. Create a job stream to backup a VSE library on a remote virtual tape as shown in the following sample job stream:

```
// JOB BACKUP (Backup a Library to a PC File)
// ON $CANCEL OR $ABEND GOTO VTAPSTOP
VTAPE START,UNIT=480,LOC=9.164.186.20:2285,          C
      FILE='D:\VSE Backup\prd2.001'
MTC REW,480
// EXEC LIBR
  BACKUP LIB=PRD2 TAPE=480
/*
/. VTAPSTOP
VTAPE STOP,UNIT=480
/&
```

Figure 10. Job Stream Example for Backing Up a VSE/ESA Library

2. Use the programs available on your Linux or Windows system to copy (burn) the VSE library from the remote virtual tape to a CD-ROM for archiving. Depending on the CD-ROM software you have installed, you may create the virtual tape backup of the VSE library directly on the CD-ROM.
3. To restore the VSE library you must create a similar job stream as the one shown for BACKUP, using the Librarian RESTORE command. You can restore the VSE library (stored as virtual tape on CD-ROM) directly from the CD-ROM back to VSE/ESA.

### Transferring Virtual Tape Files

It is possible to transfer virtual tape files between a workstation (remote virtual tape) and the VSE/ESA host (VSE/VSAM virtual tape) and vice versa with the TCP/IP File Transfer Program (FTP). For a transfer from workstation to host use

## Virtual Tape

the **put** command, for a host to workstation transfer the **get** command. Make sure you are transferring the files in **binary** mode.

The example below shows the command sequence for a transfer from server to host:

```
C:\>ftp x.x.x.x          <-- enter hostname/IP address of your VSE system
Connected to x.x.x.x.
220-TCP/IP for VSE -- Version 01.04.00 -- FTP Daemon
    Copyright (c) 1995,2001 Connectivity Systems Incorporated
220 Service ready for new user.
User (9.164.155.2:(none)): FRAN  <-- enter your user id here
331 User name okay, need password.
Password:                       <-- enter your password here
230 User logged in, proceed.
ftp> bin                        <-- switch to binary mode
200 Command okay.
ftp> quote site lrecl 16384     <-- enter the record size of your VSAM cluster
200 Command okay.
ftp> quote site recfm v        <-- set record format to variable
200 Command okay.
ftp> put tape.image VSAM.TAPE.IMAGE <-- enter your filenames
```

### Installing Optional Programs

The VSE/ESA dialog for installing optional programs has been updated and supports virtual tapes. It is thus ready for use when an optional program is available for electronic delivery. The program can then be downloaded to a virtual tape file from where it can be installed via the dialog as from any other physical tape containing optional programs.

Fastpath 111 gets you to the installation panel for defining the *cuu* and for selecting a virtual tape as input media (Figure 11). If you have selected *Virtual Tape*, the subsequent panel (Figure 12 on page 51) requests you to enter further details about the virtual tape you want to use.

The job stream created by the dialog includes statements such as VTAPE START, VTAPE STOP, DVCDN, and DVCUP.

INS\$PRI2		PREPARE FOR INSTALLATION	
Enter the required data and press ENTER.			
TAPE ADDRESS.....	181	Address of input tape unit (cuu). For valid addresses enter a "?".	
VIRTUAL TAPE.....	1	Is it a virtual tape? Enter 1 if it is a virtual tape, enter 2 if not.	
PF2=REDISPLAY 3=END			

Figure 11. Prepare for Installation Dialog

If you select Fastpath 112 (instead of 111), you get the *Install Additional Program(s) from Tape* panel. If you enter program installation information in this panel and

press PF5 (Process), you get panel INS\$0DI2 which is identical to the panel shown in Figure 11 on page 50 for specifying a virtual tape as input device.

```

UTL$VTAP          VIRTUAL TAPE: SPECIFY THE DATA SET

Enter the required data and press ENTER.

If the file resides on the VSE system specify the following:

VSAM FILE NAME .....          Unique name of the VSAM file
                               containing the tape image.

If the file resides on a remote system specify the following:

IPADDR.....          IP address of the remote system
PORT.....           TCP/IP port number

DATA SET NAME : _____
...                 _____
...                 _____
...                 _____
...                 _____
PF1=HELP           2=REDISPLAY 3=END
    
```

Figure 12. Panel for Defining Virtual Tape Details

If you enter a VSAM FILE NAME, the other fields must remain empty. Use PF1 for further details and help information.

## The VTAPE Command/Statement

You start and stop the VSE/ESA Virtual Tape Support through the **VTAPE START** and the **VTAPE STOP** command or statement.

Figure 13 shows the syntax of the VTAPE START and VTAPE STOP command/statement.

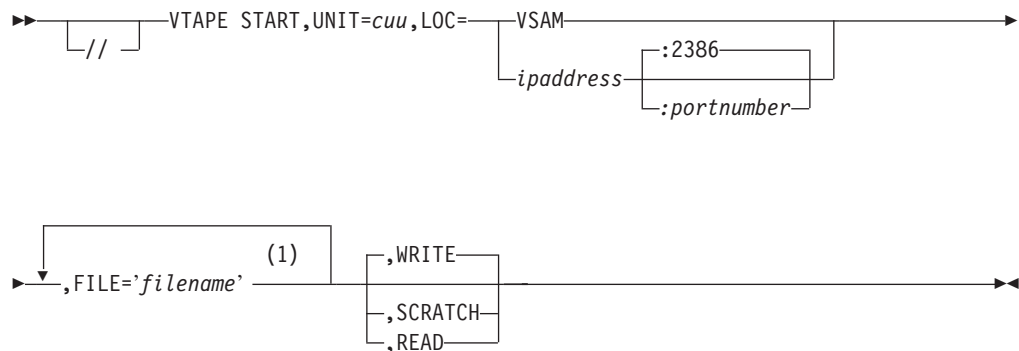

**Notes:**

- 1 FILE='filename' can be specified up to three times.



Figure 13. Syntax of VTAPE START and VTAPE STOP Command/Statement

## Virtual Tape

The operands have the following meaning:

- START** Indicates that a tape unit is to be associated with a virtual tape file. In case of *LOC=ipaddress*, a TCP/IP connection to the Virtual Tape Server workstation is established.
- STOP** Indicates that an existing association between a tape unit and a virtual tape file is to be dropped. In case *LOC=ipaddress* was specified in the corresponding START command, the TCP/IP connection to the workstation is closed.
- UNIT=cuu** Specifies the tape unit to be used for the virtual tape. The *cuu* must be added to the system like a physical tape unit with the IPL ADD command. For example:  
`ADD cuu,3480`  
  
Valid device type codes are 3480, 3490, and 3490E.
- LOC=VSAM** Indicates that the virtual tape resides in a VSE/VSAM ESDS file on the VSE/ESA system.
- LOC=ipaddress:portnumber**  
Indicates that the remote virtual tape resides on a remote system (Linux, UNIX, or Windows, for example) located on the Virtual Tape Server workstation identified by the *ipaddress*. *portnumber* specifies the TCP/IP port number to be used for the connection. If this operand is omitted, the default port number of 2386 is taken.
- FILE='filename'**  
Identifies the file which contains the virtual tape.
- For a **VSE/VSAM file**, *filename* is the 1 to 7 alphanumeric-characters filename of the DLBL statement.
  - For a **remote file**, the *filename* can be up to 100 characters in length, enclosed in quotes. The Linux, UNIX, and Windows conventions for file names apply. Refer to "File Names and other Considerations" on page 48 for further details.
- READ** Specifies that read access to the virtual tape is required.
- WRITE** Specifies that write access to the virtual tape is required. This is the default. WRITE includes READ access.  
  
When writing to **VSE/VSAM virtual tapes**, certain rules and restrictions exist. Refer to "Writing to VSE/VSAM Virtual Tapes" on page 47 for details.
- SCRATCH** Specifies that write access to the virtual tape is required and that the tape is to be cleared first. It requires REUSE in the VSE/VSAM file definition (skeleton SKVTAPE). SCRATCH includes WRITE and READ access.



---

## Information Moved From This Chapter

### Information Moved to the VSE/ESA Administration

The *VSE/ESA Administration* contains this information that was new VSE/ESA 2.6:

- Parameter EXTENTS for specifying either 16 or 32 extents when defining a library.

### Information Moved to the VSE/ESA Programming and Workstation Guide

The *VSE/ESA Programming and Workstation Guide* contains this information that was new with VSE/ESA 2.6:

- Descriptions of the *Primary Library* and *Secondary Library* dialogs which allow displayed information to be sorted by size.
- A description of the *Primary Library* dialog which offers a display option for browsing the contents of a library member.
- A description of the *Compile Job Generation* dialog which has a parameter TEMPLATE that allows the creation of an HTML template to be requested from a BMS map.

## VSE/ESA 2.6 Items

---

## Chapter 3. VSE/ESA 2.5 Items

This chapter describes the items introduced with VSE/ESA 2.5 *that were not updated in the relevant manuals*. These are the main items:

- “Interactive Interface Enhancements” on page 56
- “VSE/VSAM Buffer Hashing” on page 59
- “Miscellaneous Improvements” on page 60
- “Information Moved From This Chapter” on page 61

**Related Section:**

Chapter 4, “IXFP/SnapShot and FlashCopy Support,” on page 63

## Interactive Interface Enhancements

The following sections discuss VSE/ESA 2.5 dialog changes that were not included in the relevant manuals. The *In-Creation Queue* dialog and the *Display CICS TS Storage* dialog were new with VSE/ESA 2.5.

### Manage Batch Queues (Fastpath 32)

This dialog has been updated to enable the selection of the new VSE/POWER *In-Creation Queue* dialog. See also "In-Creation Queue (Fastpath 326)."

```

IESBQUI                                MANAGE BATCH QUEUES

  SELECT one of the following:

    QUEUE..... 6                       1 = List Queue
                                         2 = Reader Queue
                                         3 = Punch Queue
                                         4 = Transmit Queue
                                         5 = Wait for Run Subqueue
                                         6 = In-Creation Queue
                                         (Only for selections 1 to 5)

  SPECIFY optionally:

    PREFIX..... _____              To list only jobs whose names begin
                                         with certain characters
                                         (Only valid for selections 1 to 4 above)

    CLASS..... _                       To list only jobs in a certain class

    USER..... _____               To list only this user's jobs

  PF1=HELP                               3=END                               4=RETURN
  
```

Figure 14. Manage Batch Queue Dialog

### In-Creation Queue (Fastpath 326)

This dialog is new and shows queue entries which are currently being created (in-creation) by VSE/POWER tasks. In current VSE/POWER releases, similar output is displayed when using the DISPLAY ACTIVE command on the console. When completed, an in-creation queue entry is moved into its corresponding VSE/POWER queue.

```

IESBQUC                                IN-CREATION QUEUE                                Page 1 of 1

OPTIONS:  1 = DISPLAY      8 = SEGMENT      9 = SEGMENT IMMEDIATE

OPT JOBNAME NUMBER SFX CLASS LINES ID PART DEV ORIGINATOR FROM
- PAUSEBG  00308      A      260 P  BG  FED  PAUSEBG  .SYSA
- PAUSEBG  00308      A       7 L  BG  FEE  PAUSEBG  .SYSA
- CICSICCF 00242      A     1497 L  F2  FEE  CICSICCF .SYSA
- VTAMSTRT 00020      A       19 L  F3  FEE  VTAMSTRT .SYSA

PF1=HELP      2=REFRESH      3=END      4=RETURN

LOCATE JOBNAME ==> _____

```

Figure 15. In-Creation Queue Dialog

With OPTION 8 you can segment the job output at the current position (Type=List output is segmented at the next page boundary). The completed output is transferred into the corresponding output queue. A new entry is created for any subsequent output (with an incremented job suffix). Column SFX will show the job suffix (segment) number.

With OPTION 9 you can segment the job output immediately, disregarding any segmentation boundary.

## Primary Library and Secondary Library (Fastpath 51)

These dialogs offer a new function: 11=SORT.SIZE. When pressing PF-Key 11, the members of the ICCF fulist shown are sorted by size in descending order. For details, refer to the *VSE/ESA Programming and Workstation Guide*.

## Storage Dump Management (Fastpath 43)

With VSE/ESA 2.5, the *Storage Dump Management* dialog has been enhanced for CICS TS dumps and supports also CICS/VSE 2.3 dumps.

When selecting Option 9 (ANALYZE CICS DUMP) on the *Storage Dump Management* panel, VSE/ESA recognizes if a CICS coexistence environment is installed and displays the panel shown in Figure 16 on page 58 to select either CICS TS or CICS/VSE 2.3. In case of CICS TS, further panels (such as shown in Figure 17 on page 58) are displayed to specify CICS TS dump levels.

In case of CICS/VSE, the *Storage Dump Management* panel is redisplayed for selecting the CICS/VSE dump.

## Interactive Interface

```
PRB$IDHA          SPECIFY CICS VERSION

Enter the required data and press ENTER.

Dump-Name:  SYSDUMP. FB. DFB00004

You have a coexistence system with CICS 2.3 and CICS TS installed.

Please specify the CICS version with which the selected dump was produced.

CICS VERSION..... 1          Enter 1 if the dump was produced by
                               CICS TS, enter 2 if the dump was
                               produced by CICS/VSE.

                               2=REDISPLAY  3=END
```

Figure 16. Select CICS TS or CICS/VSE

```
PRB$IDH9          SPECIFY DUMP LEVELS

Enter the required data and press ENTER.

Dump-Name:  SYSDUMP. FB. DFB00004

Enter the dump level (0, 1, 2, or 3) for the following CICS component
identifiers.

AP..... _          Application domain
DS..... _          Dispatcher domain
KE..... _          CICS kernel
LD..... _          Loader domain
TR..... _          Trace domain
OTHER PARAMETERS..... 2  Enter 1 to specify any other dump
                           option, otherwise enter 2.

PF1=HELP          2=REDISPLAY  3=END
```

Figure 17. Specify Dump Levels for CICS TS Dumps

Dump levels identify the level of detail for the dump report where 0 means "none" and 3 "all details and summary". Dump levels are passed on to the CICS dump utility.

When selecting 1 for OTHER PARAMETERS, three more panels are displayed for specifying dump levels for further CICS components.

## Display Channel and Device Activity (Fastpath 362)

The layout of the display has changed. The columns CHANNEL I/O REQUESTS and CONTROL UNIT I/O REQUESTS have been removed since they are no longer meaningful in an ESA architecture environment. The display shows now the following columns:

```
DEVICE    PARTITION ID    JOB NAME    DEVICE I/O REQUESTS
```

## VSE/VSAM Buffer Hashing

Large VSAM LSR (Local Shared Resources) buffer pools can improve response time and reduce I/O operations. However, until now searching the pool to find the right buffer took time. Benefits were often reduced due to the increased CPU time needed to search large buffer pools. To overcome this reduction in performance, *VSAM Buffer Hashing* has been implemented in which a VSAM hashing algorithm allows direct access to the required buffer.

Using VSAM Buffer Hashing, you can take advantage of using very large buffer pools, without the disadvantage of additional processor load.

### What Is Buffer Hashing?

VSAM buffer hashing is a function introduced with VSE/ESA 2.5. It replaces the current buffer management for applications that use the LSR (Local Shared Resources) option. This new buffer management technique provides the following improvements over the existing sequential buffer management:

- The time required to perform buffer searches is reduced, since the need to do sequential searches through the buffer pool is removed. The new search technique uses a hashing algorithm. Using this hashing algorithm, the path length of the search is significantly shortened. The I/O rate is therefore reduced.
- The path length does not depend upon the number of buffers (therefore the search time is independent of the buffer pool size).

### How Does Buffer Hashing Work?

VSAM Buffer Hashing uses a:

- Hash Table – A table in main storage in which each table entry is used as a pointer to a BCB (Buffer Control Block). A BCB contains the address of the buffer (for data or index), and information about the buffer itself. There is one BCB for each buffer in the LSR buffer pool.
- Synonym – When using a hashing technique, synonyms may occur when two or more entities hash to the same anchor point. In VSAM Buffer Hashing, synonyms are chained together in the BCB. However, the possibility that synonyms occur is very small, and the chain is usually very short.
- Hash Algorithm, which is calculated as follows:

$$X = \text{remainder of } (RBA/2 + DSID1/2 + DSID2/2) / DIM$$

where:

**X** The remainder of the above calculation, and is used as the index to the hash table.

**RBA** The Relative Byte Address, used by VSAM to identify a certain buffer in the LSR buffer pool.

#### **DSID1 and DSID2**

The Data Set Identifiers (DSIs), which are unique identifications of a certain opened VSAM data set component, either a data or an index component.

**DIM** The number of entries in the Hash Table.  $DIM = (2N-1)$ .

**N** The number of buffers in the subpool.

Here is a "simple" example:

## Buffer Hashing

"Simple" in this case means that the values of this example were simplified to decimal values (not hexadecimal) to give a better understanding of the technique.

1. Let us assume that we have an LSR pool with 10 buffers. The Hash Table will have  $(2 * 10 - 1) = 19$  entries. Therefore:  
**DIM = 19**
2. A VSAM GET operation reads a data record from a certain VSAM data set with the internal data set identifications DSD1 and DSD2 into a data buffer.  
Therefore:  
**DSID1 = 220, DSID2 = 32**  
The BCB pointing to that data buffer is at storage location '640000'. The RBA (Relative Byte Address) of the VSAM data buffer is 800. Therefore:  
**RBA = 800**
3. The hash algorithm  $X = \text{remainder of } (RBA/2 + DSID1/2 + DSID2/2) / DIM$  therefore calculates the following index for the hash table:  
 $(800/2 + 220/2 + 32/2) / 19 = 27$ , **remainder = 13 = X**  
"13" will be used as index into the hash table.
4. The BCB pointer '640000' will be stored in the **13th position** of the hash table.
5. Whenever another request is searching for a data buffer with RBA 800 from this certain dataset, the hash algorithm can calculate easily the index of 13 into the hash table and use the BCB at address '640000' and its related data buffer without a long pool search. This hashing technique also works, of course, with very large buffer pools (for example, 32767 buffers).

---

## Miscellaneous Improvements

The following support has been added:

- The maximum BLKSIZE for tape files accessed via the DTFMT macro was limited to 32 KB. Starting with VSE/ESA 2.5, the new limit is 64 KB (BLKSIZE=65534).



---

## Information Moved From This Chapter

### Information Moved to the VSE/ICCF User's Guide

The *VSE/ICCF User's Guide* contains this information that was new with VSE/ESA 2.5:

- A description of the VSE/ICCF access to VSE/POWER queue entries by providing direct access to queue entries, access to active queue entries, and access to in-creation queue entries. For this purpose the VSE/ICCF commands /LISTP and /SKIP were changed.
- A description of program DTSGETQ, which is used to access the VSE/POWER queue entries. This program is modified so that procedures GETL, GETP, and GETR have a new operand QN (queue number). This operand can be used to specify the VSE/POWER queue entry number.

## VSE/ESA 2.5 Items

---

## Chapter 4. IXFP/SnapShot and FlashCopy Support

The following support was introduced with VSE/ESA 2.5:

- **FlashCopy Support for the IBM Enterprise Storage Server (ESS).**

The FlashCopy Support provides high-speed copying support for the Enterprise Storage Server similar to the support provided by IXFP/SnapShot for the IBM RAMAC Virtual Array (RVA).

- **IXFP/SnapShot Support Enhanced for VSE/VSAM Datasets.**

The IXFP/SnapShot support for the IBM RAMAC Virtual Array (RVA) has been enhanced. The high-speed copying of volumes also supports VSE/VSAM datasets. This is achieved by providing a new IDCAMS command (SNAP).

**Notes:**

1. From VSE/ESA 2.6 onwards, the *VSE/Fast Copy* utility program could exploit these functions for a full volume backup from disk-to-disk:

- FlashCopy.
- SnapShot (if *IXFP/SnapShot for VSE/ESA* is installed).

Refer to “VSE/Fast Copy (FCOPY) Exploitation of FlashCopy and SnapShot” on page 72 for details.

2. The IDCAMS SNAP support for VSAM datasets is also available with the FlashCopy Support for the IBM Enterprise Storage Server (ESS). Refer to “Using IXFP/SnapShot to Backup VSE/VSAM Datasets” on page 73 for details.

---

## Shipment and Installation of FlashCopy and IXFP/SnapShot Support

### FlashCopy Support:

The FlashCopy support for IBM Enterprise Storage Server (ESS) disk devices is part of VSE/ESA as shipped. The name of the phase including this support is **\$IJBIXFP** residing in sublibrary IJSYSRS.SYSLIB. This phase is automatically loaded into the SVA during startup. The FlashCopy support is provided (as for SnapShot) via the IXFP command as described under “Operation” on page 64.

### IXFP/SnapShot (and FlashCopy) Support:

The SnapShot support for IBM RAMAC Virtual Array (RVA) disk devices requires the installation of IXFP/SnapShot for VSE/ESA. IXFP/SnapShot for VSE/ESA is a priced feature and available as VSE/ESA optional program. The phase name is also **\$IJBIXFP**. Once installed, phase \$IJBIXFP includes both, the SnapShot and the FlashCopy support. You must install IXFP/SnapShot for VSE/ESA separately from the optional program tape after completing the initial installation of VSE/ESA. IXFP/SnapShot is installed per default into sublibrary PRD2.PROD. Refer also to “Fast Service Upgrade (FSU) Considerations” on page 64.

Phase \$IJBIXFP is SVA eligible and requires about 50KB. To enable the system to automatically load the phase, you must add PRD2.PROD and parameter SDL (via LIBRP/LIBRC) to the // LIBDEF statement of the LIBSDL.PROC. When changed, the // LIBDEF statement in LIBSDL.PROC looks as follows:

```
// LIBDEF PHASE,SEARCH=(PRD1.BASE,PRD2.SCEEBASE,PRD2.PROD,SDL)
```

## IXFP/SnapShot & FlashCopy

**Note:** IXFP/SnapShot requires the SDL parameter in the LIBDEF chain. Otherwise, phase \$IJBIXFP is loaded from IJSYSRS.SYSLIB, the version of the phase which supports FlashCopy only.

Instead of having phase \$IJBIXFP loaded automatically by the system, you can use the following job to load the phase into the SVA when needed:

```
// LIBDEF *,SEARCH=(PRD2.PROD,SDL)
SET SDL
$IJBIXFP,SVA
/&
```

## Fast Service Upgrade (FSU) Considerations

If you upgrade your system via FSU from VSE/ESA 2.5.x or 2.6.x to VSE/ESA 2.7 and you have IXFP/SnapShot already installed on your old system, phase \$IJBIXFP still exists after the FSU in the sublibrary into which it was installed. An exception are the sublibraries IJSYSRS.SYSLIB, PRD1.BASE, and PRD2.SCEEBAASE whose contents are replaced by the FSU.

To get the latest version of IXFP/SnapShot for VSE/ESA, you must order it separately and reinstall the program.

## Hardware Prerequisites

The SnapShot and FlashCopy support have one of the following hardware requirements:

- IBM RAMAC Virtual Array (RVA) Storage (9393) or StorageTek Iceberg 9200.
  - RAMAC Virtual Array Licensed Internal Code (LIC) 03.00.00 or higher (equivalent microcode level required for StorageTek Icebergs)
  - SnapShot requires Feature 6001 for each existing 9393 system or RPQ 8S0421 for a StorageTek Iceberg.
- IBM TotalStorage Enterprise Storage Server (ESS).

---

## Operation

### IXFP Command

The AR (Attention Routine) command IXFP enables VSE/ESA users to exploit the main facilities of the **RVA (RAMAC Virtual Array)** and the **ESS (Enterprise Storage Server)** subsystems. The main functions of the IXFP command include:

**SNAP** Take a **SnapShot** (RVA) or **FlashCopy** (ESS) copy of:

- a total VOLUME,
- a range of CYLINDERS, or
- a non-VSAM FILE.

**DDSR (available for RVA only)**

Deleted Data Space Release causes the release of the physical storage space associated with:

- expired FILES residing on **all** VSE-managed RVA volumes whose **expiration date has been reached; and, if specified explicitly, the following resources:**
  - a total VOLUME,
  - a range of CYLINDERS, or
  - a specified FILE.

**REPORT (available for RVA only)**

Provides information about the space utilization of a single or a range of RVA devices, and/or provides information about the space utilization of all devices (that have been added during IPL) of an RVA subsystem as well as important summary information on subsystem utilization.

The RVA subsystem provides a set of control and monitoring functions that extend the set of IBM 3990 control functions. Many of these functions may be invoked either from the host (for example, with IXFP/SnapShot for VSE/ESA) or directly from the RVA subsystem itself. This Extended Control and Monitoring (ECAM) interface is the protocol for communications between the host CPU and the Disk-Array-Controller. The usage of the ECAM interface by IXFP/SnapShot is generally transparent to the user.

**Command Syntax**

Figure 18. IXFP Command Syntax

**SNAP (RVA and ESS)**

**SNAP** Copies data from a source device to a target device. This function is called **SnapShot** for RVA and **FlashCopy** for ESS.

**source** This is the Device-ID (cuu) or the VOL1 label of the SOURCE device required when copying data from it onto a TARGET device. If the SOURCE device is identified by its VOLID, it must be either the only volume with that VOLID, or it must be the only VOLUME with that VOLID which is up (DVCUP), otherwise an error message will be issued. The whole VOLUME will normally be copied unless the operator has provided additional information that either identifies a cylinder range or a Data-Set-Name (DSN) contained on the source device that is to be copied.

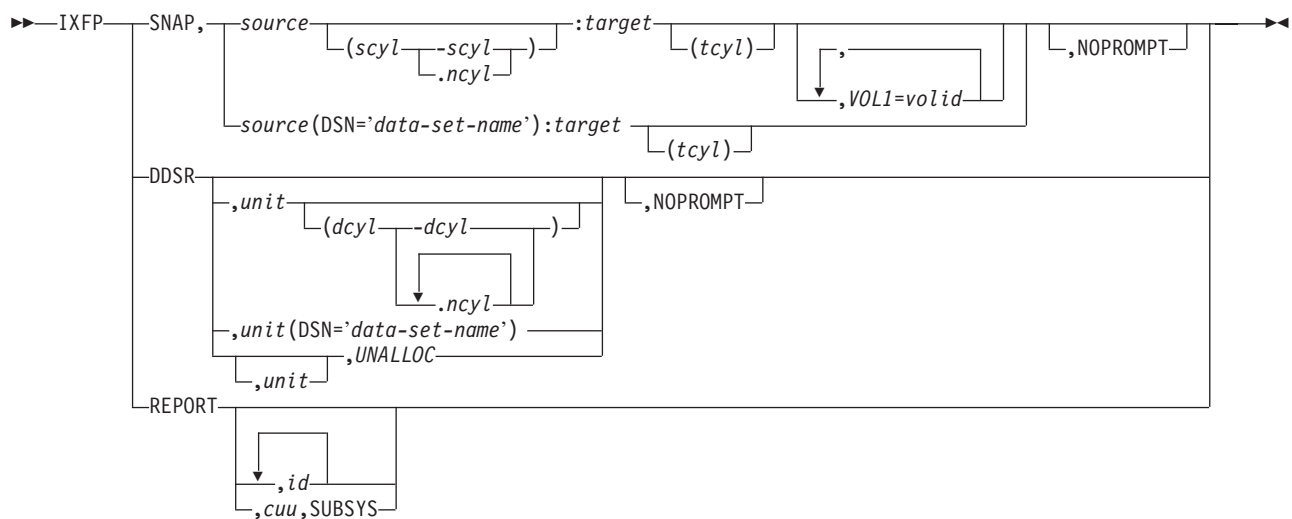
**scyl-scyl**

This specifies the decimal start- and end-cylinder range where copying is to start and where it is to end on the source device. Cylinder is the smallest entity that can be specified for any SNAP command function. The highest (end) cylinder number must not exceed the device's

primary number of cylinders and the start cylinder number must not be higher than the end cylinder number.

### **scyl.ncyl**

This specifies the decimal start-cylinder where copying is to start on the source device and provides the number of cylinders (ncyl) that should be copied. Cylinder is the smallest entity that can be specified for any SNAP command function. The highest resulting cylinder number must not exceed the device's number of primary cylinders.

**DSN=** DSN is the data-set-name, identifying the file on the source device, which must be a **non-VSAM** file, that the operator wants to be copied onto the target device. The file will be copied into the exact extent boundaries where it was located on the source device. SAM (Sequential Access Method) files, however, can be relocated (for **ESS** only: assuming that the level of the hardware support used provides this function) to a different, single extent disk location on the target device. In this case, the **tcyl** operand must be supplied but the device must **not** be a **VM-partial minidisk**. The proper label information (single FORMAT-1 label) will be created and added to the target VTOC. Processing multi-volume-files is the responsibility of the operator, such that the SNAP command should be repeated for all the source volumes containing file extents. The number of extents to be copied is limited by the limits existing for the source device. Copying will only be performed if the appropriate extent boundaries on the TARGET device are available or have already expired, otherwise an error message will be provided. (Refer to the DDSR function in case the overlaid file should be deleted and released).

**target** This is the Device-ID (cuu) or the VOL1 label of the TARGET device required when copying data to it from a SOURCE device. The target device must be set DOWN (DVCDN command) prior to initiating the SNAP function, except the source and the target device are the same device (user is copying data from one location of a disk into another location on the same disk), or except a file (DSN=data-set-name) is being copied. If the TARGET device is identified by its VOLID, it must either be the only volume with that VOLID, or it must be the only VOLUME with that VOLID which is DOWN (DVCDN), otherwise an error message will be issued. As many extents as allocated on the SOURCE device will be used for file copying onto the target device (DSN=data-set-name), otherwise as many cylinders as specified for the SOURCE device, or the whole SOURCE volume will be copied onto the TARGET device. Relocation of data records will be assumed if the specified cylinder range does not match the cylinder range that was given for the source device (for **ESS** only: assuming that the level of the hardware support used provides this function). If the cylinder range does not match the cylinder range of the source device and the target device is a **VM partial-pack minidisk**, the command will be rejected because VM uses virtual cylinder values for partial-pack minidisks and the cylinder ranges must match for VM partial-pack minidisks. For the limitations that

exist when running under VM, refer to “Usage of IXFP/SnapShot with VM Minidisks” on page 77. The source and the target device must be of the same type and must be in the same subsystem.

**tcyl** This is the decimal specification of where copying is to start on the target device. Cylinder is the smallest entity that can be specified for any SNAP command function. The target cyl specification (tcyl) added to the specified or calculated ncyl-1 value for the source device is the resulting target end cylinder address and it must not exceed the device’s primary number of cylinders.

#### **VOL1=valid**

This operand specifies the VOL1 label that the TARGET device is to receive after the source volume has been copied. This operand is required if unique VOLIDs are to be maintained, otherwise the source and the target device would have the same VOL1 label after the copy function has completed. The VOL1 label specification for a target device will only be accepted when both, the cyl and the DSN= specification have been omitted (which means copying a full VOLUME).

#### **NOPROMPT**

This keyword will prevent decision-type messages to be issued. Some messages require an operator reply before the specified function is going to be initiated. The specification of the NOPROMPT keyword will cause the system to bypass this decision-type message and will initiate the function without any additional notice.

**Note:** With the only exception of **FILE SNAPPING** (DSN=data-set-name), VSE will not perform any VTOC checking on the specified target device and will thus not provide any warning message of any kind, be it overlapping extents, secured- or unexpired files or anything else. Cylinder or volume copying will be done **unconditionally** within the specified or assumed boundaries.

## **DDSR (RVA only)**

**DDSR** Deleted Data Space Release is a function that ensures that the “logical” deletion of a dataset by the VSE system results in the “physical” deletion of the data on the RVA subsystem. DDSR, if specified without any additional operand allows the operator to delete the VTOC entries and all physical space for **all non-secured** files residing on VSE managed RVA devices whose associated expiration date has been reached and which have been created by VSE. A request will be sent to the subsystem causing the subsystem to release the physical extents that VSE considers as free space. Once released, these extents are reclaimed for free space allocation. In case a **unit** parameter has been provided without any additional operands, the data on the **total volume** will be deleted (including VTOC and the VOL1 label), which requires this volume to be re-initialized (ICKDSF) before using it as a regular data-pack again (assuming it is not going to be used as a SNAP target device in which case no initialization is required). VSE requires the volume to be **DOWN** (DVCDN command) if the whole volume or a range of cylinder is to be deleted.

**unit** This is the Device-ID (cuu) or the VOL1 label of the device that

should either be totally released, or, in case a data-set-name (DSN=data-set-name) or a cylinder range has been specified, should be released partially. The VTOC on this device will remain unchanged except a **file** was **released** in which case the appropriate labels will be deleted from the VTOC (assuming that **not** the whole volume is released and further assuming that the VTOC extent itself is not within the specified cylinder boundaries that have been released).

### **dcyl-dcyl**

This specifies the decimal start- and end-cylinder where deletion is to start and where it is to end. Cylinder is the smallest entity that can be specified for any DDSR command function. The highest (end) cylinder number must not exceed the device's primary number of cylinders and the start cylinder number must not be higher than the end cylinder number.

### **dcyl.ncyl**

This specifies the decimal start-cylinder where deletion is to start and provides the number of cylinders (ncyl) that should be released. Cylinder is the smallest entity that can be specified for any DDSR command function. The highest resulting cylinder number must not exceed the device's number of primary cylinders.

**DSN=** This is the data-set-name, identifying the file on the specified unit, which must be a **non-VSAM** file, that the operator wants to be deleted. If the specified unit is in the **UP** (DVCUP) state, then the file will be deleted **unconditionally** and the space is returned to the RVA free-space. If the device is **DOWN** (DVCDN), the command will be rejected and an error message provided. Processing multi-volume-files is the responsibility of the operator, such that the DDSR command must be repeated for all the volumes containing file extents.

## **UNALLOC**

This operand specifies that all extents for either the specified unit, or for all units attached to an RVA subsystem which are currently **UNALLOCATED**, are to be freed. In order to determine unallocated space, the VTOC of the device(s) will be scanned and all tracks which are found to be **NOT** allocated to any File ID contained in the VTOC(s) will be released. This feature has been added to allow work files that were allocated temporarily and have been released afterwards to be also released from the backend storage and be allocated to the free-space pool again.

## **NOPROMPT**

This keyword will prevent decision-type messages to be issued. Some messages require an operator reply before the specified function is going to be initiated. The specification of the **NOPROMPT** keyword will cause the system to bypass this decision-type message and will initiate the function without any additional notice.



## REPORT (RVA only)

### REPORT

Provides information about the utilization of the RVA device(s) or, in case the id parameter has been omitted, of the whole subsystem including all the devices which are known (ADDED) to the VSE system.

**id** This is the id of the device or the scope of devices for which detailed device utilization information is requested. The id can be a VOL1 label, or a Channel-ID, or a Channel+CU-ID, or it is the Device-ID. "IXFP REPORT,1F" will thus provide report information for all capable devices (full-pack RVA) in the device-ID range X'1F0' through X'1FF' that have been ADDED to the VSE/ESA system during IPL.

**cuu** The optional operand cuu must be used together with SUBSYS to correctly identify an RVA subsystem if more than one subsystem exists.

### SUBSYS

Provides summary information about the utilization of an RVA subsystem.

**Note:** The REPORT function, if used under VM, only works for full-pack minidisks or dedicated devices. Refer also to "Usage of IXFP/SnapShot with VM Minidisks" on page 77.

## IXFP Report Data Sample

```
ixfp report
AR 0015 SUBSYSTEM D401
AR 0015 *** DEVICE   DETAIL REPORT ***
AR 0015 <---FUNC. CAPACITY (MB)---> <---CAPACITY (%)--->  PHYS.  COMP.
AR 0015 CUU  DEF  ALLOC STORED UNUSED ALLOC STORED UNUSED USED(MB) RATIO
AR 0015 128 1890.7 N/A  1.0 1889.6 N/A  0.06 99.94  0.1  8.20
AR 0015 129 1890.7 N/A 1890.7  0.0  N/A 100.00  0.00  81.6 23.16
AR 0015
AR 0015 *** DEVICE   SUMMARY REPORT
AR 0015 CAPACITY   <-----TOTAL-----> <-----TOTALS %------>  COMP.
AR 0015  DEFINED                3781.463 MB 100.00                RATIO
AR 0015  STORED                1891.823 MB                50.03
AR 0015  PHYS.USED              81.756 MB                2.16 23.13
AR 0015  UNUSED                1889.639 MB                49.97
AR 0015
AR 0015 *** SUBSYSTEM SUMMARY REPORT ***
AR 0015 SYSTEM  DEFINED-CAPACITY  DISK-ARRAY-CAP  FREE-DISK-ARRAY-CAP
AR 0015  PROD    605279.761 MB    117880.209 MB    23646.525 MB
AR 0015
AR 0015 NET-CAPACITY-LOAD(%)  COLL.-FREE-SPACE(%)  UNCOLL-FREE-SPACE(%)
AR 0015 TEST  PROD  OVERALL  TEST  PROD  OVERALL  TEST  PROD  OVERALL
AR 0015  0.00 79.94 79.94  0.00 16.18 16.18  0.00 3.88 3.88
AR 0015 1140I  READY
```

## IXFP Report Data

### Definition of Field Names

The following list defines the field names and column headings of the reports provided by the REPORT function (see also the above sample).

#### \*\*\* DEVICE DETAIL REPORT \*\*\*

**cuu** This is the Device-ID of the device to which the data applies.

### <---FUNC. CAPACITY (MB)--->

This heading covers the fields that provide information about the functional capacity in megabytes for a certain device. Functional capacity in this sense is the capacity that would exist on traditional CKD or ECKD devices.

**DEF** This field contains the **functional capacity** in megabytes **DEF**ined to the subsystem for this specific device.

#### **ALLOC**

This field is the **functional space ALLOC**ated by the **VTOC**. This data is Not (yet) Available for VSE/ESA, but might be added later.

#### **STORED**

This field contains the **functional capacity** in megabytes **STORED** (occupying Disk-Array-Storage) for the device or subsystem.

#### **UNUSED**

This field contains the part of the **functional capacity** defined for the device or subsystem that is **not mapped** and thus **UNUSED** (that is, not occupying Disk-Array-Storage).

### <--- CAPACITY (%)--->

This heading covers the fields that provide information about the percentage of the **DEF**ined functional capacity assigned to the individual groups below this heading.

#### **ALLOC**

This field is the percentage of **functional space ALLOC**ated by the **VTOC**. This data is Not (yet) Available for VSE/ESA, but might be added later.

#### **STORED**

This field contains the percentage of the **DEF**ined **functional capacity** that contains **STORED** data (occupying Disk-Array-Storage) for the device or subsystem.

#### **UNUSED**

This field contains the percentage of the **DEF**ined **functional capacity** for the device or subsystem that does not yet contain data and is thus **UNUSED** (that is, not occupying Disk-Array-Storage).

### **PHYS USED(MB)**

This heading covers the field containing the **real** capacity in megabytes, as opposed to the functional capacity, that is occupying Disk-Array-Storage. The difference between the **STORED** and the **PHYS**ical **USED** capacity is the savings due to compression and compaction performed by the **RVA** subsystem for this device.

### **COMP RATIO**

This heading covers the field containing the **real** Compaction Ratio which is the quotient of Functional-capacity-STORED/PHYSicalUSED capacity.

### **\*\*\* DEVICE SUMMARY REPORT \*\*\***

#### **CAPACITY**

This column covers the capacity groups that are being differentiated.

#### **<-----TOTAL----->**

This column covers the **TOTAL** capacity in megabytes that has been allocated to the appropriate group in that line. The capacity is the sum of all the devices that had been selected for the report.

## &lt;-----TOTALS %-----&gt;

This column shows the percentage of capacity that the group in the appropriate line is occupying, always compared to the 100% **DEFINED functional capacity** in the first row. The percentage is based on **all** the devices that had been selected for the report.

**COMP. RATIO**

This column shows the **real** Compaction Ratio which is the quotient of the TOTAL-Functional-capacity-STORED/TOTAL-PHYSICALUSED capacity and is a measure for the overall **COMPACTION** for the devices selected for the report.

**\*\*\* SUBSYSTEM SUMMARY REPORT \*\*\*****SYSTEM**

This column identifies the system to which the capacity, outlined in the appropriate line applies. In case a **TEST** system has not been configured, only the **PROD** system information will be provided.

**DEFINED-CAPACITY**

This column contains the **Functional Capacity** in MegaBytes for the whole subsystem, as it has been configured.

**DISK-ARRAY-CAP**

This column contains the total **Disk Array Capacity** in MegaBytes for the whole subsystem, that has been installed.

**FREE-DISK-ARRAY-CAP**

This column contains the current **Free-Disk-Array-Capacity** in MegaBytes which is still available for **allocation** by the RVA subsystem.

**NET-CAPACITY-LOAD(%)**

This column contains the percentage of the **Disk-Array-Capacity** which is currently being occupied by the **TEST**, the **PROD** or by both (**OVERALL**) systems. This is probably the most important value and has been placed at the beginning of the very last report line to make it easy to find.

**COLL.-FREE-SPACE(%)**

This column contains the percentage of the **ARRAY-CYLINDERS** in the subsystem that are **free** array cylinders (that is, the total space that can be written to).

**UNCOLL.-FREE-SPACE(%)**

This column contains the percentage of the **ARRAY-CAPACITY** originally occupied when a functional track has been re-written to a new location in the disk array.

---

### VSE/Fast Copy (FCOPY) Exploitation of FlashCopy and SnapShot

The *VSE/Fast Copy* utility (described in the manual *VSE/ESA System Utilities*) exploits the FlashCopy function for IBM Enterprise Storage Server (ESS) devices and the SnapShot function for IBM RAMAC Virtual Array 2 (RVA) devices. It supports **full volume** backup from **disk to disk** but not the copying of files or extents.

From VSE/ESA 2.6 onwards, the ESS (FlashCopy) support is part of VSE/ESA. The RVA (SnapShot) support depends on the availability of the *IXFP/SnapShot for VSE/ESA* program, which is a priced, optional feature of VSE Central Functions.

The following VSE/Fast Copy commands are supported:

- **COPY ALL**
- **COPY VOLUME**

If the FlashCopy and SnapShot support is available, it will be used according to the device type (ESS or RVA) for which a full volume backup request was issued. If the requested support is not available, a normal VSE/Fast Copy backup will be performed.

The following VSE/Fast Copy optional parameters are supported:

```
IV (input volume)
OV (output volume)
NV (new volume)
```

The following VSE/Fast Copy optional parameters are tolerated:

```
NOPROMPT
NOVERIFY
LIST
```

The following VSE/Fast Copy optional parameters force SnapShot/FlashCopy NOT to be used. These parameters apply to COPY VOLUME only:

```
EXCLUDE
NOVSAM
NOEXPIRED
```

### Job Stream Example

The following job stream example applies to the COPY ALL as well as to the COPY VOLUME command:

```
// JOB jobname
// ASSGN SYS004,140
// ASSGN SYS005,141
// EXEC FCOPY
COPY VOLUME IV=SYSRES
/*
/&
```

## Using IXFP/SnapShot to Backup VSE/VSAM Datasets

### Background

Previous to VSE/ESA 2.5, the IXFP/SnapShot feature could not be used for backing up VSE/VSAM datasets because in the *snapped volume* (the target volume) that is produced by IXFP/SnapShot:

1. At DEFINE time of a VSAM dataset, all information about the dataset is saved in the catalog (dataset name, dataset attributes, VOLIDs, extent information, and so on).
2. Any access to a VSAM dataset is directed via:
  - a. the name of its owning catalog
  - b. the VOLID of the affected DASD volume, found in the catalog
  - c. the name of the dataset, found in the catalog
  - d. the extents of the dataset, found in the catalog
  - e. certain dataset attributes (such as "indexed", for example).

Or in other words:

1. VSAM dataset names, VOLIDs, and extent information are saved in the catalog.
2. Access to a VSAM dataset requires the correct name of the catalog, the correct name of the dataset, and the correct VOLID.

In addition, duplicate VOLIDs cannot be used within the same VSE/ESA system, especially where VSE/VSAM datasets are accessed.

To overcome these limitations, from VSE/ESA 2.5 onwards an IDCAMS **SNAP** command is supported which you must use together with IDCAMS BACKUP and a *synonym list*. Run the following IDCAMS commands:

1. IDCAMS SNAP with a *synonym list* (similar to that used for the IDCAMS BACKUP) to control the source and snapped (target) volumes for the IXFP/SnapShot program. Snapped volumes are created. These snapped volumes are not available for normal VSAM access: they are therefore *very safe*.
2. IDCAMS IMPORT CONNECT to inform the VSE/ESA system that a copy of the User Catalog now exists on the *snapped volume*, and that this copy of the User Catalog now has a *synonym name*.
3. IDCAMS BACKUP against the snapped volumes, using the *synonym list*.

**Note:** This sequence of steps works for both, VSAM datasets residing on the IBM RAMAC Virtual Array (RVA) or on the IBM Enterprise Storage Server (ESS).

### Prerequisites

To use IDCAMS SNAP together with the synonym list, the following is required when your datasets reside on an RVA:

The optional program IXFP/SnapShot for VSE/ESA (5686-066). Its phase \$IJBIXFP must reside in the SVA.

### Advantages in Creating a SnapShot of Entire Disk Volumes

These are the advantages in using IDCAMS SNAP together with a synonym list, to produce *SnapShots* of volumes:

1. After a SnapShot of disk volumes is complete, backup processing *can be started immediately* and can run *during online processing*.
2. During the very short "copy-time" of the SnapShot (which may be minutes, or even **seconds**), online systems only have to be shut down for a very short time.

3. There is no risk of losing data.
4. There is faster access to the snapped (target) datasets.
5. There are no catalog changes on the snapped (target) catalog.
6. Error-prone and time-consuming catalog changes are not required on the snapped catalog. The snapped catalogs remains 100% unchanged. The snapped catalogs and the datasets could then be used for disaster recovery (for example, to replace one or more complete disk volumes).
7. When the SnapShot is made, the contents of the snapped (target) volumes remain identical to the contents of the source volumes. This is very important if you must carry out a disaster recovery.
8. Any BACKUP jobs that you run after the SnapShot, will use “frozen” data on the snapped volumes. This data is independent of any data changes that take place on the online systems.
9. Running IDCAMS SNAP and IDCAMS BACKUP using a synonym list significantly reduces the time during which your system is unavailable.

### Using IDCAMS SNAP and BACKUP With a Synonym List

These are the steps you should follow:

#### 1. Run IDCAMS SNAP using the Synonym List.

Use the IDCAMS SNAP to create a SnapShot of all entire disk volumes where the catalog and all its datasets reside. Give the snapped (target) volumes different VOLIDs than the source volumes. **Note:** The snapped (target) volumes will then be online after the IDCAMS SNAP has run.

This is the syntax of the IDCAMS SNAP command:

```
SNAP
    SOURCEVOLUMES(volser[ volser...])
    TARGETVOLUMES(volser[ volser...])
    [NOPROMPT|PROMPT]
```

where:

**SOURCEVOLUMES(volser[ volser...])**

**TARGETVOLUMES(volser[ volser...])**

Are a pair of lists indicating from which volumes, and to which volumes, the SnapShot is to be done.

Abbreviations: SVOLUME or SVOL, TVOLUME or TVOL

**NOPROMPT**

This keyword prevents decision-type messages from being issued.

**PROMPT**

This keyword allows decision-type messages to be issued.

#### 2. Run IDCAMS IMPORT CONNECT.

You run IDCAMS IMPORT CONNECT to inform the VSE/ESA system that a copy of the User Catalog now exists on the *snapped (target) volume*, and that this copy of the User Catalog now has a *synonym name*.

**Notes:**

- a. The catalog that has a synonym name now exists (including its datasets), but *cannot be accessed* by normal applications.
- b. You use a snapped (target) Master Catalog in the same way as you use a snapped (target) User Catalog.

#### 3. Run IDCAMS BACKUP using the Synonym List.

IDCAMS BACKUP uses the parameters contained in the synonym list:

- The synonym list is used to route the VSAM OPEN and BACKUP functions to the snapped (target) volumes.
- The BACKUP works in the same way as previously, *except* that it uses the synonym list to access the snapped volumes. Therefore, you can use all features of IDCAMS BACKUP.
- You can use the output from this IDCAMS BACKUP (that uses a synonym list) in the same way as before (for IDCAMS RESTORE).

This is the syntax of the IDCAMS BACKUP command:

```
BACKUP .....
      SYNONYMLIST(                               -
        SOURCEVOLUMES(volser[ volser...]) -
        TARGETVOLUMES(volser[ volser...]) -
        CATALOG(catname[/password])         -
        SYNONYMCATALOG(catname[/password]) )
```

where:

#### **SYNONYMLIST**

Indicates that this backup uses a synonym list of "snapped" VSAM volumes.

Abbreviations: SYNLIST or SYNL

#### **SOURCEVOLUMES(volser[ volser...])**

#### **TARGETVOLUMES(volser[ volser...])**

Are a pair of lists indicating from which volumes, and to which volumes, SnapShot has to be done.

Abbreviations: SVOLUME or SVOL, TVOLUME or TVOL

#### **CATALOG(catname[/password])**

Specifies the name and the password of the source catalog, which is the original catalog from which a SnapShot was done.

Abbreviation: CAT

#### **SYNONYMCATALOG(catname[/password])**

Specifies the synonym name and password of the snapped (target) catalog which was copied (using SnapShot) to the snapped (target) volume. You must ensure that the synonym name of the catalog has been imported using IMPORT CONNECT, before running the IDCAMS BACKUP. The password is identical to the password of the source catalog. **Note:** You must provide the synonym name of the catalog in a DLBL statement containing filename IJSYSUC.

Abbreviation: SYNCAT

For reference purposes, Figure 19 on page 76 shows the internal structure of the synonym list:



Offset	Source	Target
0	Header with Eye Catcher	
8	Source Catalog / Source Password	Target Catalog / Target Password
112	Source Volume 1	Target Volume 1
124	Source Volume 2	Target Volume 2
...	...	...
	End of List	

Figure 19. Internal Structure of Synonym List

## Example of Running IDCAMS SNAP /BACKUP With a Synonym List

The following jobstream example shows how to:

1. Create a SnapShot of the *source* volumes *SYSWK1* and *DOSRES* to the *snapped* (*target*) volumes *VOLSN1* and *VOLSN2*.
2. Run an IDCAMS IMPORT CONNECT to inform the VSE/ESA system that a copy of the User Catalog (VSESP.USER.CATALOG on *SYSWK1* and *DOSRES*) now exists on the snapped (*target*) volume, and that this copy of the User Catalog now has a *synonym name* (VSESP.SNAP.CATALOG).
3. Run an IDCAMS BACKUP that uses the parameters contained in the synonym list.

### Input

```
// JOB SNAP and BACKUP from snapped Volumes
// ASSGN SYS005,180
// DLBL IJSYSUC,'VSESP.SNAP.CATALOG',,VSAM
// EXEC IDCAMS,SIZE=AUTO
/* First: do the SNAPSHOT */      -
  SNAP
    SOURCEVOLUMES(SYSWK1,DOSRES) -
    TARGETVOLUMES(VOLSN1,VOLSN2)
/* Second: Synonym Name for the snapped Catalog */-
IMPORT CONNECT OBJECTS((VSESP.SNAP.CATALOG -
  VOLUMES(VOLSN1) DEVT(3390)))          -
  CATALOG(VSAM.MASTER.CATALOG)
/* Third: Backup from snapped volumes */-
BACKUP (*)                               -
  SYNONYMLIST(                            -
    SOURCEVOLUMES(SYSWK1,DOSRES)         -
    TARGETVOLUMES(VOLSN1,VOLSN2)         -
    CATALOG(VSESP.USER.CATALOG)          -
    SYNCATALOG(VSESP.SNAP.CATALOG)       )
/*
/&
```

You can also use the dialog *Flashcopy VSAM Catalog/Files* (Fastpath 3719) to create such a job stream. For details, refer to “Chapter 10: Managing VSE/VSAM Files and Catalog” in the *VSE/ESA Administration*.

### Output

The output from using IDCAMS BACKUP (with a synonym list) is any normal backup media (tape or disk). This is the same as any other IDCAMS BACKUP output.



---

## Usage of IXFP/SnapShot with VM Minidisks

The IXFP REPORT function, if used on a VSE/ESA system running under VM, only works (and will only be accepted as a valid command) for full-pack minidisks or dedicated devices. Partial minidisks cannot be used with the REPORT function.

The IXFP SNAP function, if used on a VSE/ESA system running under VM, does not allow volume or cylinder relocation for **partial minidisks**.

You have to consider that for minidisks which are using MDC (Mini Disk Caching) the MDC buffer must be flushed before performing a SNAP or DDSR function, otherwise data can be incomplete. The MDC problem is solved by VM APAR VM61486.

**Note:** Other host caching products (for example, Cache Magic) will have the same requirements.

---

## Operating in Batch

A small REXX/VSE procedure can be used to issue IXFP commands from a batch job. The following example shows such a procedure:

```
* $$ JOB JNM=IXFPREXX,CLASS=0,DISP=D
// JOB IXFPREXX
// EXEC LIBR
ACC S=PRD2.CONFIG
CAT IXFPREXX.PROC R=Y
/* rexx/vse procedure */
/* to issue console commands */
trace off
rc = SENDCMD('your-console-cmd-1') /* enter your 1st IXFP cmd here */
call sleep 5 /* wait for 5 seconds */
rc = SENDCMD('your-console-cmd-2') /* enter your 2nd IXFP cmd here */
exit rc
/+
/*
// LIBDEF *,SEARCH=(PRD2.CONFIG,PRD1.BASE)
// EXEC REXX=IXFPREXX
/&
* $$ E0J
```

More information on the REXX/VSE Console Automation Capability can be found in the *REXX/VSE Reference* manual, SC33-6642.



---

## Chapter 5. Publication Updates

This chapter describes information that belongs to the manuals listed here.

---

### VSE/ESA System Control Statements

For the manual *VSE/ESA System Control Statements*, SC33-6713-02, the following changes and enhancements apply:

1. The IPL ADD command (page 15) supports mode 1 for OSAX devices, identifying them as HiperSockets devices.
2. On page 65 (Table 4), a new device class has been added: **TPA**. TPA comprises TPA devices with different track characteristics, such as TPAT128, TPAT256, and TPAT384. If you need to assign a 256-track TPA tape unit for example, specify:

```
ASSGN SYSxxx,TPAT256
```

If you specify

```
ASSGN SYSxxx,TPA
```

VSE/ESA first searches for 128-track TPA devices, then 256-track TPA devices, and finally 384-track TPA devices.

3. On page 155 for the NPGR command: the default number for programmer logical units has been increased from 30 to 40.

The current number of programmer logical units allocated to each partition can be displayed with the LISTIO NPGR command.

---

### VSE/ESA System Macros Reference

For the manual *VSE/ESA System Macros Reference*, SC33-6716-00, the following updates and corrections apply:

1. **GETVCE** macro:  
AMODE: 24 or 31  
RMODE: ANY
2. **LIBRDCB** and all **LIBRM xxx** macros:  
AMODE: 24 or 31  
RMODE: ANY
3. On page 184, the description of the **EOJ** (End of Job) macro needs to be corrected:
  - 0 is not a valid return code and should be removed.
  - The last sentence must read: If the operand is omitted, no return code is passed to Job Control.
4. On page 288, the description of the Return Code 4/Reason Code 0 for **LIBRM STATE MEMBER** needs to be corrected as follows: the sentence *Continuation is possible* must be replaced by *Continuation is required to free partition GETVIS storage*.
5. On page 291, the description of the Return Code 4/Reason Code 0 for **LIBRM STATE SUBLIB** needs to be corrected as follows: the sentence *Continuation is possible* needs to be replaced by *If CONT=YES (default) was specified, a continuation request is required to free partition GETVIS storage*.

## Publication Updates

6. On page 299, the three syntax diagrams (Format 1, Format 2, and Format 3) which describe the FREEVIS (Free Virtual Storage) Macro contain these errors:
  - LENGTH=0 should read LENGTH=(0)
  - ADDRESS=(name1) should read ADDRESS=name1
  - LENGTH=(name1) should read LENGTH=name2

---

## VSE/ESA Guide to System Functions

For the manual *VSE/ESA Guide to System Functions*, SC33-6711-00, the following updates applies:

1. Section *Restore a SYSRES File, Library, Sublibrary, or a Member* in "Chapter 4. Using VSE Libraries" mentions the OLDLIB parameter. However, the OLDLIB parameter is no longer supported.
2. On page 32, in the section "Loading Phases into the SVA", paragraph four needs to be replaced by the following text:

In addition, during system startup VSE/ESA loads SVA-eligible phases through the SET SDL command into the SVA. This command maintains the SDL (system directory list) which includes the names of the phases that are to be loaded into the SVA. The operator can use the SET SDL command (from the BG partition) at any time after system startup to load phases into the SVA.

---

## VSE/ESA Guide for Solving Problems

For the manual *VSE/ESA Guide for Solving Problems*, SC33-6710-00, the following update applies:

On page 174 in Figure 47, a `// UPSI 1` statement needs to be added before the `// EXEC DITTO` statement.

---

## VSE/ESA System Utilities

For the manual *VSE/ESA System Utilities*, SC33-6717-00, the following updates apply:

- On page 12 under "Reorganization of Files", the following note needs to be added:

**Note:** Relocation of files dumped with user-labels will lead to restored files containing the user-labels as normal data extents and further open processing will not call the user-label processing routines.

- On page 15, the following note needs to be added to the description of the OUTFILE parameter:

**Note:** The EXTENT statements will overrule any user-label extents that were dumped or have to be copied. Therefore, the user labels are handled as data and further open processing on the restored or copied files will not call the user-label processing routines.

---

## VSE/VSAM Commands

In "Chapter 3. Sample IDCAMS Command Job Streams" in the manual *VSE/VSAM Commands*, SC33-6731-00, the **Backup Example 7** (on page 313) shows a job stream with a missing /\* statement. The correct job stream is listed below:

```
// JOB BACKUP7
// TLBL TAPE1, 'BACKUP.FILE1'
// EXEC IDCAMS, SIZE=AUTO
   BACKUP (*) COMPACT -
       STDLABEL(TAPE1) -
       NOREWIND

/*
// TLBL TAPE2, 'BACKUP.FILE2'
// EXEC IDCAMS, SIZE=AUTO
   BACKUP (VSAM.USER.CATALOG.A) COMPACT -
       STDLABEL(TAPE2) -
       NOREWIND

/*
/&
```

---

## VSE/VSAM User's Guide and Application Programming

For the manual *VSE/VSAM User's Guide and Application Programming*, SC33-6732-00, the following update applies:

On page 250, BUFFERS=size(number) of the BLDVRP macro: the maximum value for **number** is **32767**.

---

## VSE/ESA Library Control Device Driver for IBM 3494

For the manual *VSE/ESA Library Control Device Driver for IBM 3494*, SC33-6740-00, the following update applies to "Chapter 3. LCDD Customization and Start-Up", section "Defining Customization Options with Control Statements". The following text is to be added as last paragraph of the **Device List** description (on page 27):

For each drive, the rightmost character of the ccuu must correspond with the device number of that drive in the subsystem. Device numbers for any control unit start with 0. For a typically 4-drive subsystem, these devices would be 0, 1, 2, and 3 and could go higher with 3590 adjacent frame support (for example, when 3590

## Publication Updates

drives in one frame are attached to a control unit located in an adjacent frame that is already fully populated with drives).

---

# Index

## Special characters

\$IJBIXFP, phasename  
SnapShot/FlashCopy support 63

## Numerics

3390-9 disk device 19  
3494 tape library 5  
3592 J1A tape drive  
    and 3494 tape library 5  
    ASSGN statement 4  
    IPL changes 4  
    macro changes 4  
    support for 4

## A

adapter-interruption facility for OSA  
    Express 3  
APAR DY46015 9  
APAR DY46030 5  
APAR DY46031 7  
APAR DY46063 7  
APAR DY46107 8  
AR commands 64  
ATM 25

## B

BACKUP (IDCAMS) 73  
buffer hashing, VSE/VSAM 59

## C

Compile Job Generation dialog 32  
Configure Hardware dialog 31  
Crypto support 10

## D

DB2 Version 7 Release 3 5  
defining HiperSockets 13  
dialogs  
    Compile Job Generation 32  
    Configure Hardware 31  
    Display Channel and Device  
        Activity 58  
    In-Creation Queue 56  
    Manage Batch Queue 56  
    Storage Dump Management 57  
    TCP/IP Configuration 31  
Display Channel and Device Activity  
    dialog 58

## E

encryption support 10

Enterprise Storage Server (ESS)  
    FlashCopy support 63  
    IXFP command 64

## F

Fast Ethernet 25  
FlashCopy support for ESS 63

## G

G5 processors 25  
G6 processors 25  
GETVIS/FREEVIS trace (SDAID) 35  
Gigabit Ethernet 25

## H

Hardware Crypto support 10  
    Crypto support and External Security  
        Manager 12  
    support characteristics 10  
    under z/VM 11  
HiperSockets device 30  
HiperSockets support 13  
    device and link definitions in  
        TCP/IP 14  
    device definitions in VSE/ESA 14  
    IOCP configuration 13  
    support overview 13  
homepage, VSE/ESA ix

## I

IBM TotalStorage ESS 18  
IDCAMS BACKUP 73  
IDCAMS IMPORT CONNECT 73  
IDCAMS SNAP 74  
In-Creation Queue dialog 56  
Interactive Interface enhancements 56  
IPL enhancements 30  
IXFP command 64  
IXFP/SnapShot  
    support for ESS 63  
    support for RVA 63  
    support for VSAM datasets 73  
IXFP/SnapShot support for RAMAC  
    Virtual Array (RVA) 63

## K

Keyman/VSE tool for SSL 5

## L

Large DASD 19

## M

Manage Batch Queue dialog 56

## N

non-QDIO architecture 25  
NOPDS system 29

## O

optional programs that cannot be  
    ordered 2  
OSA Express support 25  
    ATM 25  
    Fast Ethernet 25  
    Gigabit Ethernet 25  
    invoking the support 26  
    non-QDIO architecture 25  
    QDIO architecture 25  
    Token Ring 25

## P

performance enhancements  
    VSAM buffer hashing 59  
Publication Updates 79

## Q

QDIO adapter-interruption facility 3  
QDIO architecture 25

## R

RAMAC Virtual Array (RVA)  
    IXFP command 64  
    SnapShot support 63  
Remote Virtual Tape 48

## S

SDAID traces  
    GETVIS/FREEVIS trace 35  
    XPCC trace 33  
SDAID XPCC trace 33  
SNAP (IDCAMS) 74  
SnapShot (IXFP/SnapShot)  
    support for VSAM datasets 73  
SnapShots, of entire disk volumes 73  
SSL  
    setting up for using Keyman/VSE 5  
Storage Dump Management dialog 57  
synonym list 73

## T

TAPESVRV job 41  
TCP/IP Configuration dialog 31  
TERSE utility 38  
Token Ring 25  
TotalStorage ESS support 18

## U

utilities  
GETVIS/FREEVIS trace (SDAID) 35  
TERSE utility 38  
VSE/Fast Copy utility (exploiting  
SnapShot/FlashCopy) 72  
XPCC trace (SDAID) 33

## V

Virtual Tape Data Handler 40  
Virtual Tape Server 41  
Virtual Tape Simulator 40  
Virtual Tape support 40  
Backing Up and Restoring Data 49  
Examples of Using Virtual Tapes 49  
Implementation 40  
installing Virtual Tape Server 42  
installing VSE/ESA optional  
programs 50  
Overview 40  
remote virtual tape 48  
startup of Virtual Tape Data  
Handler 41  
Transferring Virtual Tape Files 49  
Virtual Tape support 40  
VSE/VSAM virtual tape 45  
VTAPE command/statement 51  
VSE/ESA 2.5 support  
Display Channel and Device  
dialog 58  
In-Creation Queue dialog 56  
information moved to other  
manuals 61  
Manage Batch Queue dialog 56  
Storage Dump Management  
dialog 57  
VSE/ESA 2.6 support  
GETVIS/FREEVIS trace 35  
information moved to other  
manuals 53  
Interactive Interface  
enhancements 31  
IPL enhancements 30  
OSA Express support 25  
overview VSE/ESA 2.6 25  
TERSE utility 38  
Virtual Tape support 40  
VTAPE command/statement 51  
XPCC trace (SDAID) 33  
VSE/ESA 2.7 support  
defining HiperSockets 13  
Hardware Crypto support 10  
HiperSockets support 13  
information moved to other  
manuals 23  
Interactive Interface  
enhancements 16

VSE/ESA 2.7 support (*continued*)  
more space in SVA-24 and in CICS  
DSA 18  
no longer supported optional  
programs 2  
support introduced 1  
support of 3390-9 disk device 19  
TotalStorage ESS support 18  
VSE/VSAM support of Large  
DASD 19  
VSE/ESA homepage ix  
VSE/Fast Copy utility (exploiting  
SnapShot/FlashCopy) 72  
VSE/POWER  
disable display of unimportant  
messages 5  
eliminate DBLK tracing performance  
impact 7  
extend number of IPWSEGM spooling  
attributes 8  
improve firewall support 9  
SET NORUN=YES for dynamic  
partitions 7  
VSE/VSAM  
buffer hashing 59  
IXFP/SnapShot support for 73  
performance enhancements 59  
support of Large DASD 19  
VSE/VSAM support of Large DASD 19  
VSE/VSAM Virtual Tape 45  
VTAPE command/statement 51

## X

XPCC trace (SDAID) 33

## Z

z/VM 11, 13  
zSeries 800 processors 10, 13, 25  
zSeries 890 processor support 3  
zSeries 900 processors 10, 13, 25  
zSeries 990 processor support 3



---

## Readers' Comments — We'd Like to Hear from You

IBM VSE/Enterprise Systems Architecture  
VSE/ESA Release Guide  
Version 2 Release 7 Modification Level 2

Publication No. SC33-6718-08

Overall, how satisfied are you with the information in this book?

	Very Satisfied	Satisfied	Neutral	Dissatisfied	Very Dissatisfied
Overall satisfaction	<input type="checkbox"/>	<input type="checkbox"/>	<input type="checkbox"/>	<input type="checkbox"/>	<input type="checkbox"/>

How satisfied are you that the information in this book is:

	Very Satisfied	Satisfied	Neutral	Dissatisfied	Very Dissatisfied
Accurate	<input type="checkbox"/>	<input type="checkbox"/>	<input type="checkbox"/>	<input type="checkbox"/>	<input type="checkbox"/>
Complete	<input type="checkbox"/>	<input type="checkbox"/>	<input type="checkbox"/>	<input type="checkbox"/>	<input type="checkbox"/>
Easy to find	<input type="checkbox"/>	<input type="checkbox"/>	<input type="checkbox"/>	<input type="checkbox"/>	<input type="checkbox"/>
Easy to understand	<input type="checkbox"/>	<input type="checkbox"/>	<input type="checkbox"/>	<input type="checkbox"/>	<input type="checkbox"/>
Well organized	<input type="checkbox"/>	<input type="checkbox"/>	<input type="checkbox"/>	<input type="checkbox"/>	<input type="checkbox"/>
Applicable to your tasks	<input type="checkbox"/>	<input type="checkbox"/>	<input type="checkbox"/>	<input type="checkbox"/>	<input type="checkbox"/>

Please tell us how we can improve this book:

Thank you for your responses. May we contact you?  Yes  No

When you send comments to IBM, you grant IBM a nonexclusive right to use or distribute your comments in any way it believes appropriate without incurring any obligation to you.

---

Name

---

Address

---

Company or Organization

---

Phone No.



Fold and Tape

Please do not staple

Fold and Tape



NO POSTAGE  
NECESSARY  
IF MAILED IN THE  
UNITED STATES

# BUSINESS REPLY MAIL

FIRST-CLASS MAIL PERMIT NO. 40 ARMONK, NEW YORK

POSTAGE WILL BE PAID BY ADDRESSEE

IBM Deutschland Entwicklung GmbH  
Department 3248  
Schoenaicher Strasse 220  
D-71032 Boeblingen  
Federal Republic of Germany



Fold and Tape

Please do not staple

Fold and Tape





File Number: S370/S390-34  
Program Number: 5690-VSE

Printed in USA

SC33-6718-08



Spine information:



VSE/ESA

Release Guide

Version 2 Release 7  
Modification Level 2

SC33-6718-08