



IBM System z Technical Conference Dresden – Germany – May 5-9



E72 - z/VSE Performance Update



Ingo Franzki – ifranzki@de.ibm.com

Trademarks

The following are trademarks of the International Business Machines Corporation in the United States and / or other countries.

CICS*	IBM*	Virtual Image
DB2*	IBM logo*	Facility
DB2 Connect	IMS	VM/ESA*
DB2 Universal	Intelligent	VSE/ESA
Database	Miner	VisualAge*
e-business logo*	Multiprise*	VTAM*
Enterprise Storage	MQSeries*	WebSphere*
Server	OS/390*	xSeries
HiperSockets	S/390*	z/Architecture
	SNAP/SHOT	z/VM
	*	z/VSE
		zSeries

* Registered trademarks of IBM Corporation

The following are trademarks or registered trademarks of other companies.

LINUX is a registered trademark of Linus Torvalds

Tivoli is a trademark of Tivoli Systems Inc.

Java and all Java-related trademarks and logos are trademarks of Sun Microsystems, Inc., in the United States and other countries

UNIX is a registered trademark of The Open Group in the United States and other countries.

Microsoft, Windows and Windows NT are registered trademarks of Microsoft Corporation.

SET and Secure Electronic Transaction are trademarks owned by SET Secure Electronic Transaction LLC.

Intel is a registered trademark of Intel Corporation.

Disclaimer

The information contained in this document has not been submitted to any formal IBM test and is distributed on an "AS IS" basis without any warranty either express or implied. The use of this information or the implementation of any of these techniques is a customer responsibility and depends on the customer's ability to evaluate and integrate them into the operational environment. While each item may have been reviewed by IBM for accuracy in a specific situation, there is no guarantee that the same or similar results will be obtained elsewhere. Customers attempting to adapt these techniques to their own environments do so at their own risk.

In this document, any references made to an IBM licensed program are not intended to state or imply that only IBM's licensed program may be used; any functionally equivalent program may be used instead.

Any performance data contained in this document was determined in a controlled environment and, therefore, the results which may be obtained in other operating environments may vary significantly. Users of this document should verify the applicable data for their specific environments.

It is possible that this material may contain reference to, or information about, IBM products (machines and programs), programming, or services that are not announced in your country. Such references or information must not be construed to mean that IBM intends to announce such IBM products, programming or services in your country.

Agenda

- § Hardware support
- § z/VSE V4 Considerations
 - z/Architecture
 - 64-bit real addressing
 - Paging
- § Sizing a system for z/VSE
- § Miscellaneous Considerations

z/VSE 4.1 Hardware support

- § z/VSE 4.1 runs on the following machines
 - IBM System z9 BC or z9 EC (formerly z9-109)
 - IBM zSeries: z800, z900, z990, z890
 - z/VM V5.2 (or later) is a prerequisite for running z/VSE V4.1 under VM

- § z/VSE 3.1 and VSE/ESA 2.7 runs on the following machines
 - IBM System z9 BC or z9 EC (z9-109)
 - IBM zSeries: z800, z900, z990, z890
 - 9672 Parallel Enterprise Server (G5/G6)
 - Multiprice 3000 (7060)
 - equivalent emulators (Flex-ES)

Supported VSE Releases

VSE Release	Available	End of Marketing	End of Service
z/VSE 4.2	Previewed	-	-
z/VSE 4.1	03/16/2007	-	-
z/VSE 3.1	03/04/2005	05/31/2008	07/31/2009
VSE/ESA 2.7	03/14/2003	09/30/2005	02/28/2007 (out of service)
VSE/ESA 2.6	12/14/2001	03/14/2003	03/31/2006 (out of service)
VSE/ESA 2.5	09/29/2000	12/14/2001	12/31/2003 (out of service)
VSE/ESA 2.4	06/25/1999	09/29/2000	06/30/2002 (out of service)
VSE/ESA 2.3	07/12/1997	06/30/2000	12/31/2001 (out of service)

Running z/VSE V4 under z/VM

- § z/VM V5.2 (or later) is a prerequisite for running z/VSE V4.1 under z/VM
 - If you IPL z/VSE V4.1 in a guest system of z/VM version 4 or z/VM 5.1, you may experience severe performance problems
 - Because of that the following message is issued during IPL:
 - 0J86I WARNING: VM RELEASE NOT SUPPORTED BY VSE 4.1 - Z/VM 5.2 OR LATER REQUIRED
 - If you receive this message, you must urgently upgrade your VM system to z/VM 5.2 or a later release.

- § Note: It is not required to run z/VSE under z/VM, you can also run z/VSE in an LPAR

VSE Server Support

IBM Server	z/VSE 4.1	z/VSE 3.1	VSE/ESA 2.7 (*)	VSE/ESA 2.6 (*)	VSE/ESA 2.5 (*)	VSE/ESA 2.4/2.3 (*)
IBM System z9 BC/EC (z9-109)	Yes	Yes	Yes	Yes (PTF required)	Yes (PTF required)	No
zSeries 890, 990	Yes	Yes	Yes	Yes (PTF required)	Yes (PTF required)	No
zSeries 800, 900	Yes	Yes	Yes	Yes	Yes	Yes
S/390 Parallel Enterprise Server G5/G6	No	Yes	Yes	Yes	Yes	Yes
S/390 Multiprise 3000	No	Yes	Yes	Yes	Yes	Yes
S/390 Parallel Enterprise Server G3/G4	No	No	No	Yes	Yes	Yes
S/390 Multiprise 2000	No	No	No	Yes	Yes	Yes
S/390 Integrated Server	No	No	No	Yes	Yes	Yes
S/390 Parallel Enterprise Server G2 / G1 (out of Service)	No	No	No	Yes	Yes	Yes
ES/9000 – 9221, 9121, 9021 (out of Service)	No	No	No	Yes	Yes	Yes
P/390 and R/390 (out of Service)	No	No	No	Yes	Yes	Yes

(*) Note: Although VSE/ESA 2.7 or earlier releases technically run on selected servers, these releases are Out-of-Service anyway.

VSE Hardware Support

VSE Release	HiperSockets	OSA Express (QDIO mode)	Hardware Crypto
z/VSE 4.1	Yes	Yes	Yes (PCICA, CEX2C, CEX2A, CPACF)
z/VSE 3.1	Yes	Yes	Yes (PCICA, CEX2C, CEX2A, CPACF)
VSE/ESA 2.7	Yes	Yes	Yes (PCICA, CPACF)
VSE/ESA 2.6	No	Yes	No
VSE/ESA 2.5	No	No	No
VSE/ESA 2.4	No	No	No
VSE/ESA 2.3	No	No	No

Crypto Card	z800	z900	z890	z990	z9 BC/EC
PCICA	No	Yes	Yes	Yes	No
CEX2C	No	No	Yes	Yes	Yes
CPACF	No	No	Yes	Yes	Yes
CEX2A	No	No	No	No	Yes

Overhead Deltas for VSE Releases

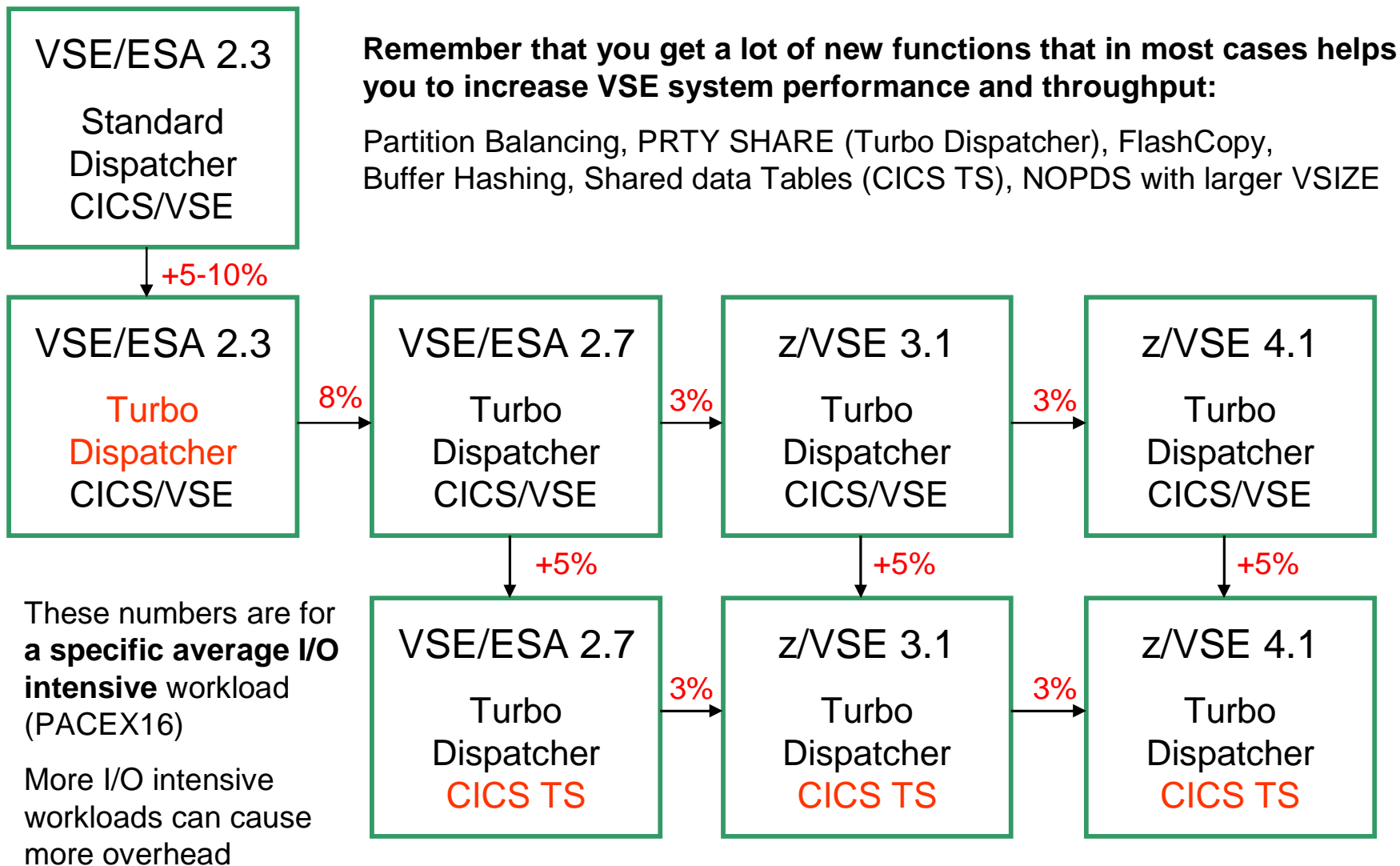

z/VSE 4.1 - z/Architecture mode

§ **z/VSE 4.1:**

- Supports z/Architecture-capable (64-bit) processors.
- Executes in z/Architecture mode only.
- Supports 64-bit real addressing for selected system functions.
- Supports processor storage up to 8 GB.
- The storage beyond 2 GB is managed exclusively by the z/VSE operating system

§ **z/VSE 4.1 does not support:**

- 64-bit virtual addressing. The size of a virtual address or data space remains restricted to 2 GB.
- For user applications, 64-bit addressing and operations that use 64-bit registers

§ **64-bit real addressing is transparent to your user applications providing you use IBM-supplied standard interfaces**

§ **Customers with especially large z/VSE environments might benefit from lower paging rates**

§ **Many z/VSE environments might be able to run without a page data set (using the NOPDS option).**

What does 64 Bit 'real addressing' mean ?

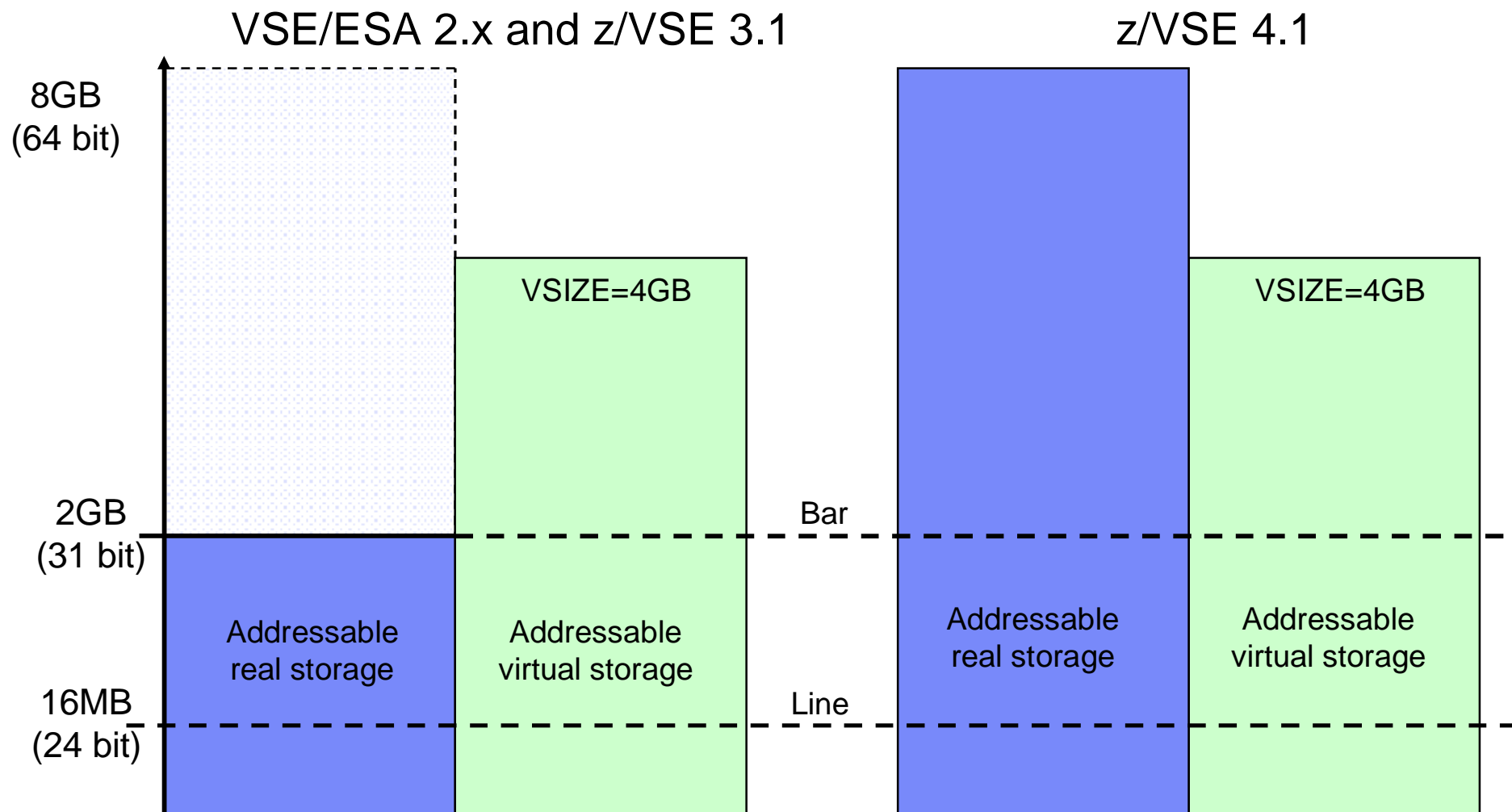

What does 64 Bit 'real addressing' mean ?

§ VSE/ESA V2.x and z/VSE 3.1

- z/VSE 3.1 or below can address only 2 GB of processor storage
 - 31 bit (real) addressing
- Page data set required if VSIZE (+VIO) > ~ 2GB
- No page data set required as long 2 GB processor storage is sufficient

§ z/VSE 4.1

- z/VSE 4.1 can address up to 8 GB of processor storage
 - 64 bit (real) addressing
- No page data set required
 - If processor storage >= VSIZE (+VIO)
- Virtual address spaces and data spaces are still limited to 2 GB
 - 31 bit (virtual) addressing
 - No changes required to applications

z/VSE 4.1 – Example with 3 GB of real storage

```

map real
AR 0015 AREA          R-SIZE   R-ADDR   PFIX(BELOW)      PFIX(ABOVE)
AR 0015                ACTUAL   LIMIT     ACTUAL   LIMIT
AR 0015 SUP           52K      0
AR 0015 SYS-24        592K     14136K
AR 0015 BG V          0K       0K       0K       0K
AR 0015 F1 V         148K     400K     0K      1400K
AR 0015 F2 V          32K     144K     0K       0K
AR 0015 F3 V          88K     424K     0K       0K
AR 0015 F4 V          0K       0K       0K       0K
AR 0015 F5 V          0K       0K       0K       0K
AR 0015 F6 V          0K       0K       0K       0K
AR 0015 F7 V         200K     400K     1044K    2100K
AR 0015 F8 V          0K       0K       0K       0K
AR 0015 F9 V          0K       0K       0K       0K
AR 0015 FA V          0K       0K       0K       0K
AR 0015 FB V          0K       0K       0K       0K
AR 0015 SYS-31        7404K    2052264K
AR 0015 DYN-PA        0K       0K       0K       0K
AR 0015 AVAIL         64K
AR 0015 SYSTEM        25068K
AR 0015 TOTAL         3145728K
AR 0015
AR 0015 AVAILABLE FOR SETPFIX: 13544K
AR 0015
AR 0015 1I40I READY
    
```

Exploiting 64 Bit real storage

- § Even on VSE/ESA or z/VSE 3.1 the VSIZE could ‘theoretically’ be up to 90G
- § ‘Practically’ you are limited by
 - Page dataset size and number of extents
 - Page I/O rate
 - Too heavy page I/O rates makes VSE almost unusable
- § With z/VSE 4.1 you can run with VSIZE+VIO up to approximately 8GB without a page dataset (NOPDS)
 - If enough processor storage is available
 - No time consuming page I/Os
- § You can have more large partitions in your system

Paging considerations

- § 'Paging' is another word for Page Manager activities
 - Assigning real pages to virtual pages
 - Writing pages to the page data set (page-out I/O)
 - Reading pages from the page data set (page-in I/O)

- § Even with 8GB real storage and NOPDS paging happens
 - Assigning real pages to virtual pages
 - Moving pages from <2G to >2GB (above the bar) and vice versa

- § 'Paging' as such is not bad
 - But page I/Os are 'bad' (dependent on the page I/O rate)

Paging considerations - PMRMON

§ New SIR command: SIR PMRMON

- Displays reports from the 'Page Manager Monitor'
- Shows number of page faults, page I/Os, page exchanges (31 <-> 64), ...

§ Usage:

- `SIR PMRMON=ON` (resets counters)
- `// run your workload`
- `SIR PMRMON`
- `SIR MPRMON=OFF`

§ Output example, see next foil

§ The output displays mainly internal counters that are for evaluation by IBM support persons

Paging considerations - PMRMON

```

AR 0015                PAGE MANAGER MONITORING REPORT
AR 0015                (BASED ON A 0000:01:04.801 INTERVAL)
AR 0015 IPFQ 31-BIT    =      517126    IPFQ 64-BIT    =      115185
AR 0015  PSQ 31-BIT    =       1500     PSQ 64-BIT    =       527
AR 0015 PF EXCH TOTAL  =       4673     PF EXCH 31->64 =         0
AR 0015 PF EXCH 64->31 =       4673     PGFLT TOTAL    =      25825
AR 0015 PGFLT PMGR     =         0      PGFLT USER     =      25825
AR 0015 PGFLT IMM PO 31 =         0      PGFLT IMM PO 64 =         0
AR 0015 SELCT ON PSQ 31 =         0      SELCT ON PSQ 64 =         0
AR 0015 SELC R=1 MAX 31 =         0      SELC R=1 MAX 64 =         0
AR 0015 RECLAIMS       =         0      NPSQ LOW       =         0
AR 0015 PGOUT I/O TOTAL =         0      PGIN I/O TOTAL =         0
AR 0015 PGOUT I/O UNC. =         0      PGOUT I/O PRE. =         0
AR 0015 LRA PGM CHECK  =       3904     TFIX 64-BIT FR =       768
AR 0015 1I40I  READY

```

Paging considerations - PMRMON

IPFQ 31-BIT	Number of unused page frames below 2G
PSQ 31-BIT	Number of page frames below 2G in page selection queue
IPFQ 64-BIT	Number of unused page frames above 2G
PSQ 64-BIT	Number of page frames above 2G in page selection queue
PF EXCH TOTAL	Total number of times a page frame exchange is requested
PF EXCH 31->64	Number of times a page frame is exchanged from below 2G to above 2G (e.g. instead of page-out I/O)
PF EXCH 64->31	Number of times a page frame is exchanged from above 2G to below 2G (e.g. TFIX)
PGFLT TOTAL	Total number of page faults
PGFLT PMGR	Number of page faults handled by page manager task
PGFLT USER	Number of page faults handled immediately without activating page manager task
PGFLT IMM PO 31	Number of page faults forcing an immediate page-out of a page frame below 2G
PGFLT IMM PO 64	Number of page faults forcing an immediate page-out of a page frame above 2G
SELCT ON PSQ 31	Number of page selection events on page frames below 2G
SELCT ON PSQ 64	Number of page selection events on page frames above 2G
SELC R=1 MAX 31	Maximum number of cycles on a page selection event for page frames below 2G
SELC R=1 MAX 64	Maximum number of cycles on a page selection event for page frames above 2G
RECLAIMS	Number of times page frames are reclaimed from the page-out queue
NPSQ LOW	Number of times the available page frames are below a critical minimum
PGOUT I/O TOTAL	Total number of page-out I/O
PGIN I/O TOTAL	Total number of page-in I/O
PGOUT I/O UNC.	Total number of unconditional page-out I/O
PGOUT I/O PRE.	Total number of pre-page-out I/O
LRA PGM CHECK	Number of special operation program exceptions on LRA
TFIX 64-BIT FR	Number of TFIX requests with page frames above 2G involved

Sizing a system for z/VSE

- § Sizing a system for z/VSE is different from sizing a system for z/OS
 - Although z/VSE supports multiprocessing, z/VSE does not scale as efficient as z/OS does
 - Do not use more than 3 active processors per z/VSE LPAR or z/VM Guest

- § In general, **a faster single CPU is better** than multiple smaller CPUs
 - One partition (=data space in z/OS) can only exploit the power of one CPU
 - The largest partition (e.g. CICS) must fit into one single CPU
 - Dependent on nonparallel share (NPS) value

- § Additional CPUs can be useful when multiple LPARs or z/VM Guests are used
 - Define only up to 3 CPUs per LPAR or z/VM Guest, even if more than 3 CPUs are available on the CEC

Sizing a system for z/VSE

§ If you have the choice between:

- 1 CPU with 100 MIPS
- 2 CPUs with 50 MIPS each (~ 100 MIPS in total)

§ ... choose the uni-processor system !

- Gives each VSE partition (e.g. CICS) the chance to get the full 100 MIPS
 - If no other job takes away CPU power
 - Dependent on the priorities and shares

§ z/VM or LPAR hypervisor does a very good job in dispatching virtual CPUs to its guests

- Set SHARE accordingly (e.g. give more the production system a higher share than development/test systems)

Sizing a system for z/VSE

**The fastest
uni-processor
is (almost always *)
the best processor**

(*) from a single VSE-image point o view

Sizing a system for z/VSE

- § To do proper capacity planning, a good understanding of the **CPU utilization** is required
 - What is the CPU utilization over a day, week, month
 - Where are the peaks ?
- § A performance monitor is required (CA Explore, ASG TMON) to get that information
 - Use CPUMON if no other monitor product is available (see next foils)
 - Use z/VM Performance Toolkit (if running under z/VM)
- § Have performance monitor data available for **at least a typical month** before you start the migration
- § Collect the same data when you run on the new system
 - **Keep the data** (old and new) for several month after the migration

New VSE CPU Monitor Tool

- § Intended to help customers to **measure the CPU utilization** of their VSE system **over a period of time**.
- § When you plan for a processor upgrade it is very important to know the CPU utilization of your VSE system over a day or a week.
 - Helps you to estimate the size of the new processor.
- § The VSE CPU Monitor Tool is not intended to replace any existing monitoring product provided by partners.
- § It provides only very **basic monitoring** capabilities on **an overall VSE system level**.
- § No details about CPU usage of certain applications are provided
- § **Download**
 - <http://www.ibm.com/servers/eserver/zseries/zvse/downloads/tools.html>
 - ‘As is’, no official support, e-mail to zvse@us.ibm.com

New VSE CPU Monitor Tool

- § CPUMON **periodically** issues a TDSERV FUNC=TDINFO macro to get performance relevant data.
- § The data provided by the macro is the same as command **QUERY TD** shows.
- § The data from each measurement interval is printed to SYSLST in a comma separated format.
- § Later on this data can be imported into a spreadsheet (EXCEL)
- § CPUMON runs in a VSE partition (dynamic or static).
- § CPUMON is started using:

```
// EXEC DTRIATTN,PARM='SYSDEF TD,RESETCNT`  
/*  
// EXEC CPUMON,PARM='nn'   nn = interval in seconds  
/*
```

- § The tool can be stopped by entering the following command:

```
MSG xx,DATA=EXIT           xx = partition id
```

New VSE CPU Monitor Tool

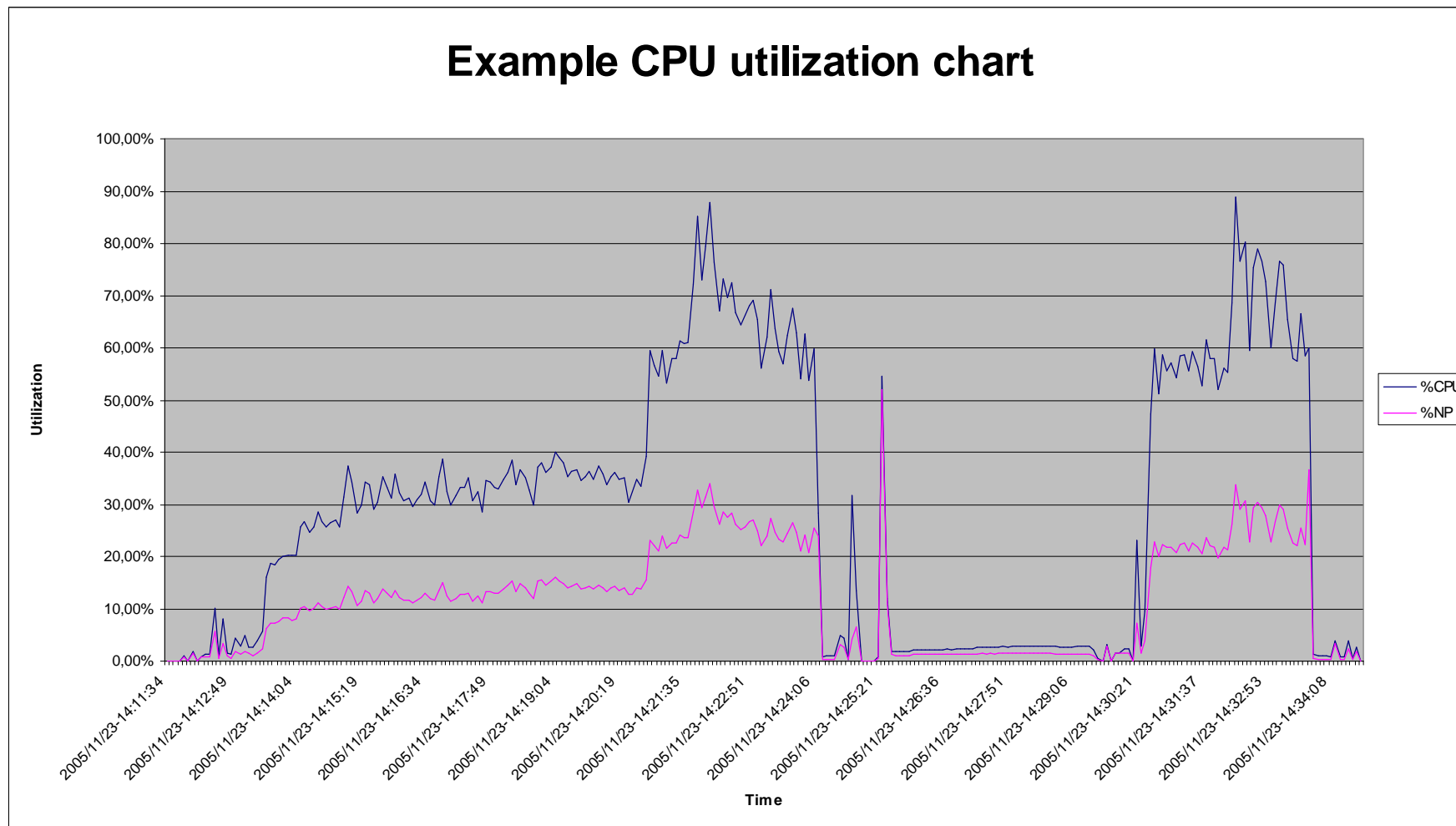

IBM Processor Capacity Reference for System z (zPCR)

- § The zPCR tool was released for customer use on October 25, 2005
 - <http://www.ibm.com/support/techdocs/atmastr.nsf/WebIndex/PRS1381>
 - ‘As is’, no official support, e-mail to zpcr@us.ibm.com
- § PC-based productivity tool under Windows
- § It is designed to provide capacity planning insight for IBM System z9 and eServer zSeries processors running various workload environments
- § Capacity results are based on IBM's LSPR data supporting all IBM System z9 and eServer zSeries processors
 - Large System Performance Reference:
<http://www.ibm.com/servers/eserver/zseries/lspr/>
- § For VSE use z/OS CB-L workload (similar to CBW2 = Commercial Batch Workload 2)
 - CB-L fits best to most VSE workloads

IBM System z9 BC (1-4 CPUs)

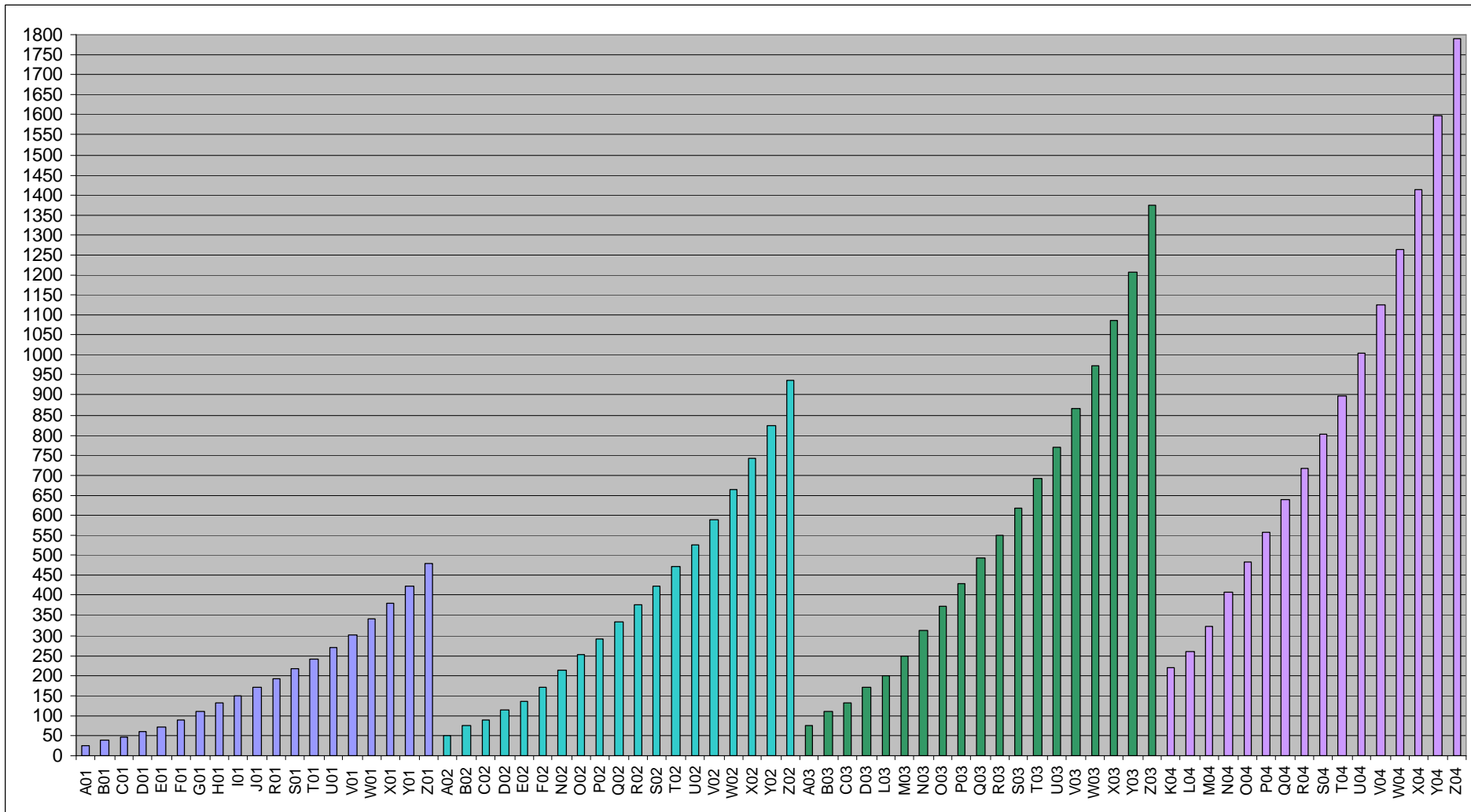

Note: Do not use MIPS to do any kind of capacity planning, use the zPCR tool instead !

IBM System z9 EC subcapacity models (1-8 CPUs)

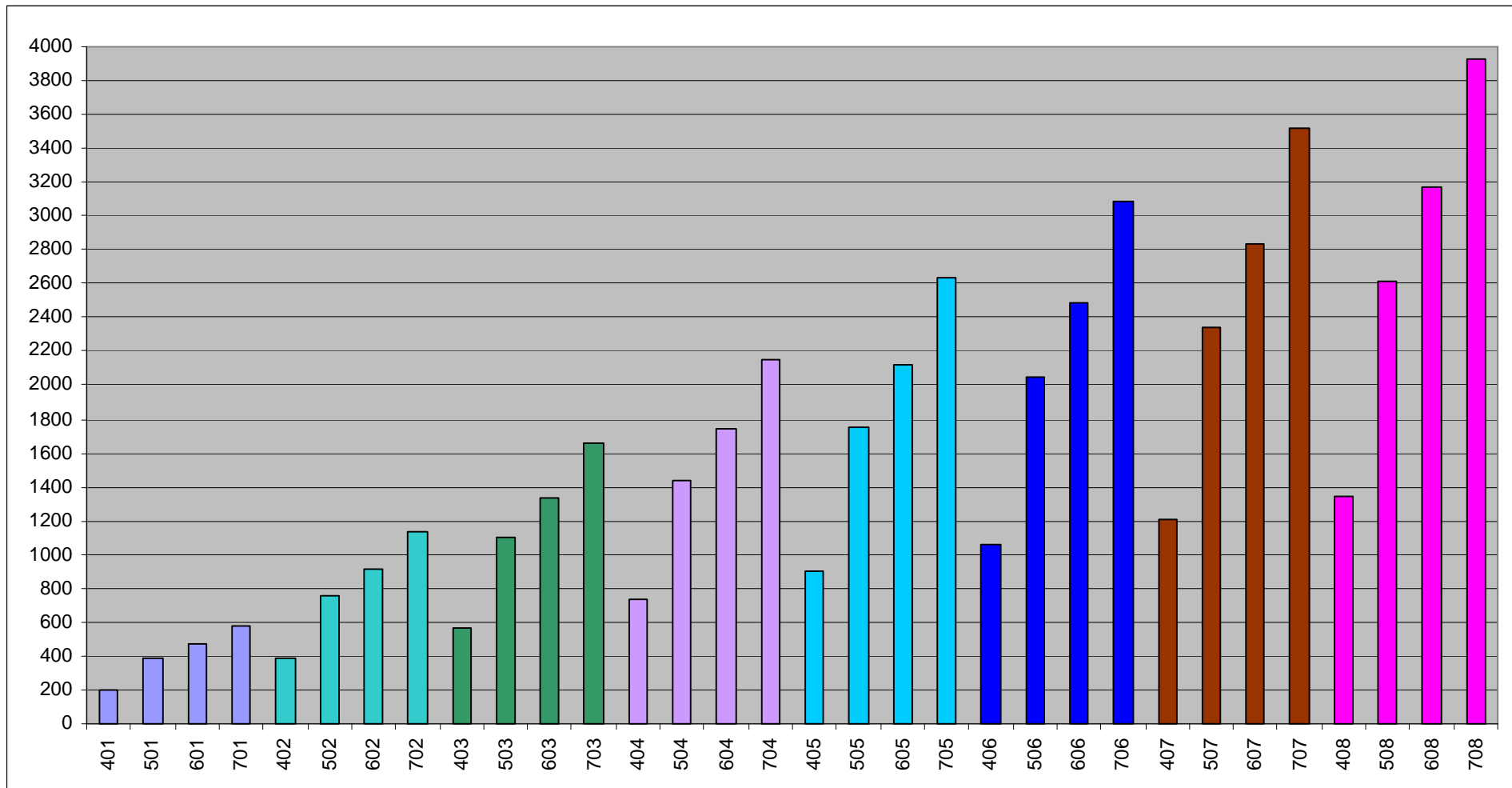

Note: Do not use MIPS to do any kind of capacity planning, use the zPCR tool instead !

IBM System z9 EC (9-54 CPUs)

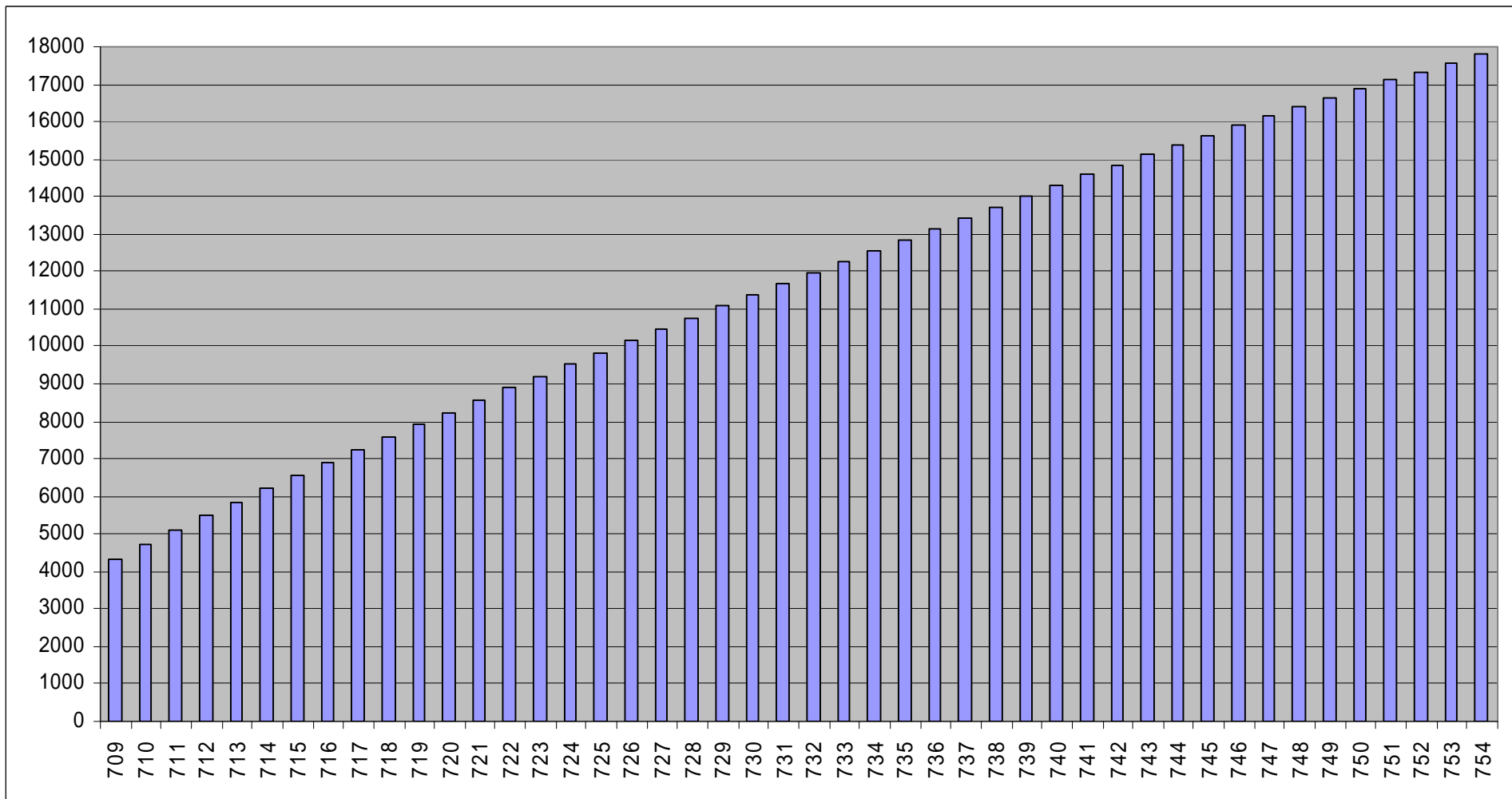

Note: Do not use MIPS to do any kind of capacity planning, use the zPCR tool instead !

Midrange Workload License Charge (MWLC)

- § MWLC is a new monthly license charge price metric on the IBM System z9 servers
 - Full-capacity: based on the IBM rated capacity of the z9 Server
 - Sub-capacity: based on the utilization of the LPARS or z/VM guests
- § It applies to z/VSE V4 and 12 key VSE-related middleware programs
 - such as CICS TS for VSE, ACF/VTAM for VSE, and DB2 Server for VSE.
- § MWLC is only available on z9 EC and z9 BC servers with z/VSE V4.
- § It is NOT a performance topic
 - Just for pricing
- § Capacity Measurement Tool
 - Measures used MSUs (Millions of Service Units) per image (z/VM guest or LPAR)
 - Measurement interval = 30 minutes
 - Calculates 4 hour rolling average
 - Not to be used for performance tuning !
- § For more details see
 - IBM System z9 and eServer zSeries Software Pricing:
<http://www.ibm.com/servers/eserver/zseries/swprice/>
 - IBM's MSU ratings for the z9 Servers:
<http://www.ibm.com/servers/eserver/zseries/library/swpriceinfo/hardware.html>

z890, z990 and z9 BC and z9 EC Considerations

- § The z890, z990 and z9 BC and z9 EC (formerly z9-109) are LPAR-only machines
 - No basic mode any more
 - Even if you run just one VSE system, it now runs in an LPAR
 - Running z/VSE systems under z/VM means
 - running z/VSE in z/VM in an LPAR
 - No I/O Assist in LPARs
 - Only available if z/VM runs in basic mode, but no basic mode available on z890, z990, z9 BC and z9 EC

z/VM V5 considerations

- § z/VM V5 no longer supports V=R and V=F guests
- § z/VM V5 no longer support I/O Assist
 - If you currently run with preferred guests, you will need to estimate and plan for a likely increase in processor requirements as those preferred guests become V=V guests as part of the migration.
 - Refer to Preferred Guest Migration Considerations at <http://www.vm.ibm.com/perf/tips/z890.html> for assistance and background information
- § How to size the impact (on your current system)
 - **Loss of I/O Assist:** Run your workload with CP SET IOASSIST OFF and measure the increase
 - **Loss of V=R/F:** Run your workload with V=V and use the CP Monitor to watch for increased CPU consumption
- § How to tune
 - **Dedicated processors:** CP SET SHARE ABSOLUTE
 - **Dedicated memory:** CP SET RESERVED
 - **I/O Assist:** Use minidisks, turn minidisk caching on (MDC)
- § Note: z/VM V5.2 (or later) is a prerequisite for running z/VSE V4.1 under z/VM

Turbo Dispatcher - Design

§ TD dynamically assigns partitions to CPUs

- Work unit = from assignment to one CPU until next interrupt/SVC
- If one task (subtask) of a partition is active, no other task of the same partition will be selected
- TD dispatches on partition-basis, not on task-basis
- A job running in a partition is processed in several work units.

Turbo Dispatcher - Design (2)

§ parallel work units

- application code (CICS, Batch)
- may run on any CPU concurrently with other parallel or non-parallel work units.

§ non-parallel work units

- system code (Services, VTAM, Vendor code)
- As long as one non-parallel work unit is active on one CPU, no other non-parallel work unit can execute on any other CPU.

Turbo Dispatcher – Design Example 1

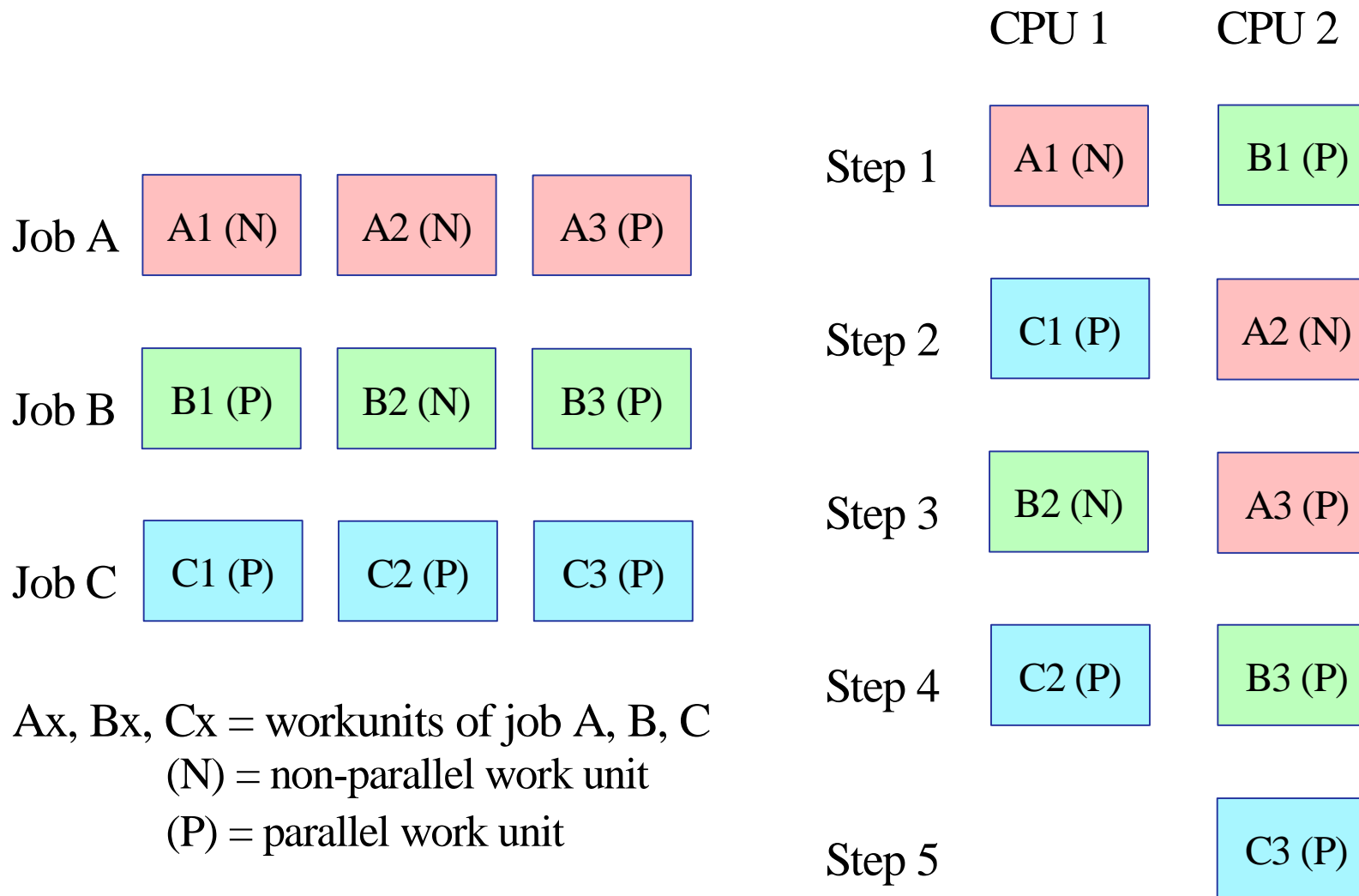

Turbo Dispatcher – Design Example 2

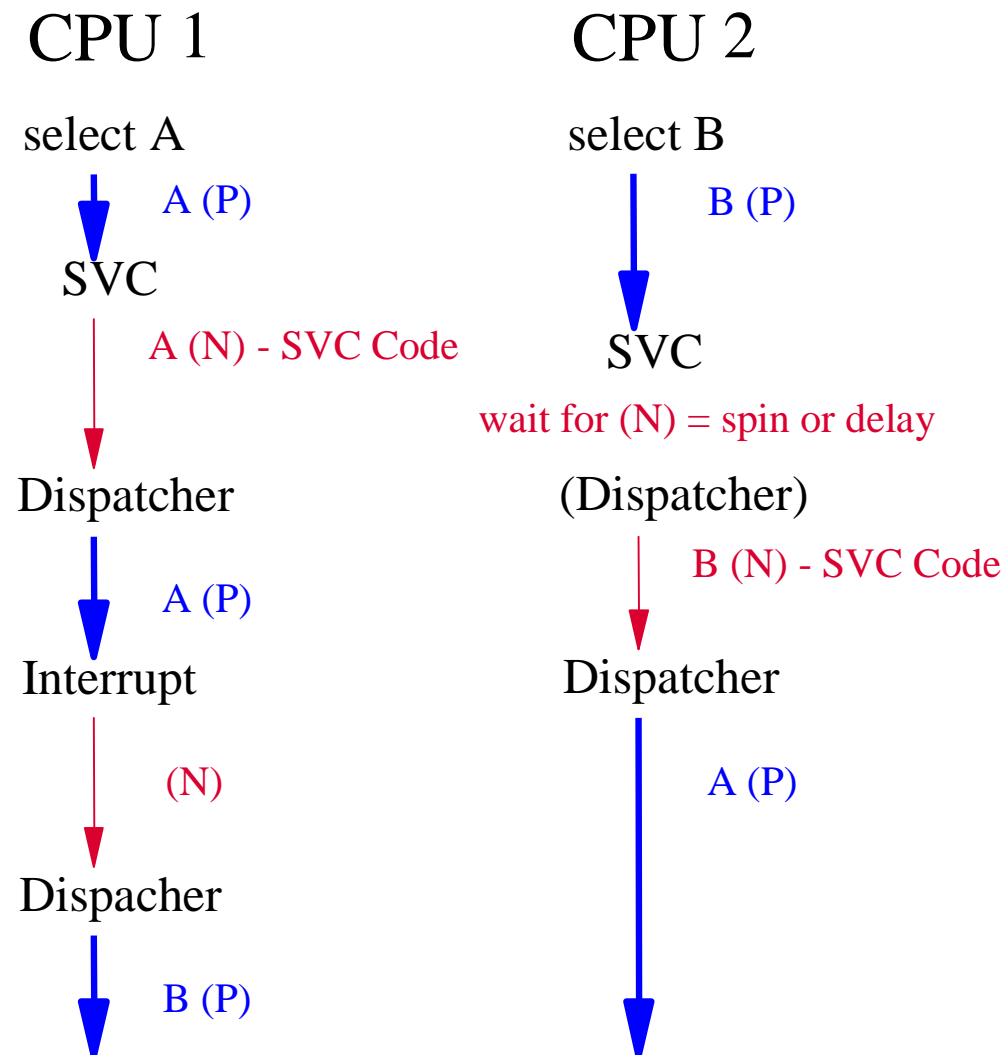

Turbo Dispatcher - CPU time measurement

§ CPU time measurement (overall system)

- SYSDEF TD,RESETCNT
- Workload (e.g. run a job)
- QUERY TD (QUERY TD,INTERNAL)

CPU	STATUS	SPIN_TIME	NP_TIME	TOTAL_TIME	NP/TOT
00	ACTIVE	0	237100	416698	0.568
01	ACTIVE	0	157556	415229	0.379
02	QUIESCED	0	0	0	*.***
03	INACTIVE				

TOTAL		0	394656	831927	0.474

NP/TOT: 0.474 SPIN/(SPIN+TOT): 0.000

OVERALL UTILIZATION: 179% NP UTILIZATION: 85%

ELAPSED TIME SINCE LAST RESET: 463433

NP/TOT = non-parallel share (NPS)
 SPIN_TIME = CPU time waiting for NP

Display System Activity Dialog

```

Session C - [32 x 80]
File Edit View Communication Actions Window Help
IESADMDA          DISPLAY SYSTEM ACTIVITY          15 Seconds 13:55:26
*--- SYSTEM (CPUs: 1 / 0) ---* *----- CICS : DBDCCICS -----*
| CPU      :    0%   I/O/Sec:    1   | | No. Tasks:  7,018   Per Second :    *   |
| Pages In :    0   Per Sec:    *   | | Dispatchable:    0   Suspended  :    3   |
| Pages Out:    0   Per Sec:    *   | | Peak Active :    7   MXT reached:    0   |
*-----* *-----*
Priority: Z,Y,S,R,P,C,BG,FA,F9,F8,F6,F5,F4,F2,F7,FB,F3,F1

  ID S JOB NAME   PHASE NAME  ELAPSED      CPU TIME    OVERHEAD    %CPU      I/O
  F1 1 POWSTART   IPWPOWER    29:23:33     1.23        .37          6,000
  F3 3 VTAMSTRT   ISTINCVT    29:23:28    18.13        5.65        304,230
  FB  B SECSERV   BSTPSTS     29:23:33     .03          .01          213
 *F7 7 TCPIP00   IPNET       29:23:28     1.61          .77          814
  F2 2 CICSICCF   DFHSIP      29:23:28    597.71       169.82       8,718
  F4 4 <=WAITING FOR WORK=> .00          .00          2
  F5 5 <=WAITING FOR WORK=> .00          .00          2
  F6 6 <=WAITING FOR WORK=> .00          .00          2
  F8 8 <=WAITING FOR WORK=> .00          .00          2
  F9 9 <=WAITING FOR WORK=> .00          .00          2
  FA A <=WAITING FOR WORK=> .00          .00          2
  BG 0 <=WAITING FOR WORK=> .00          .00          2
PF1=HELP      2=PART.BAL.   3=END        4=RETURN     5=DYN.PART   6=CPU
    
```

Migration path

VSE/ESA 2.3
Standard Dispatcher
CICS/VSE 2.3

VSE/ESA 2.3
Turbo Dispatcher
CICS/VSE 2.3

z/VSE 3.1
(Turbo Dispatcher)
CICS/VSE 2.3

z/VSE 3.1
(Turbo Dispatcher)
CICS TS 1.1

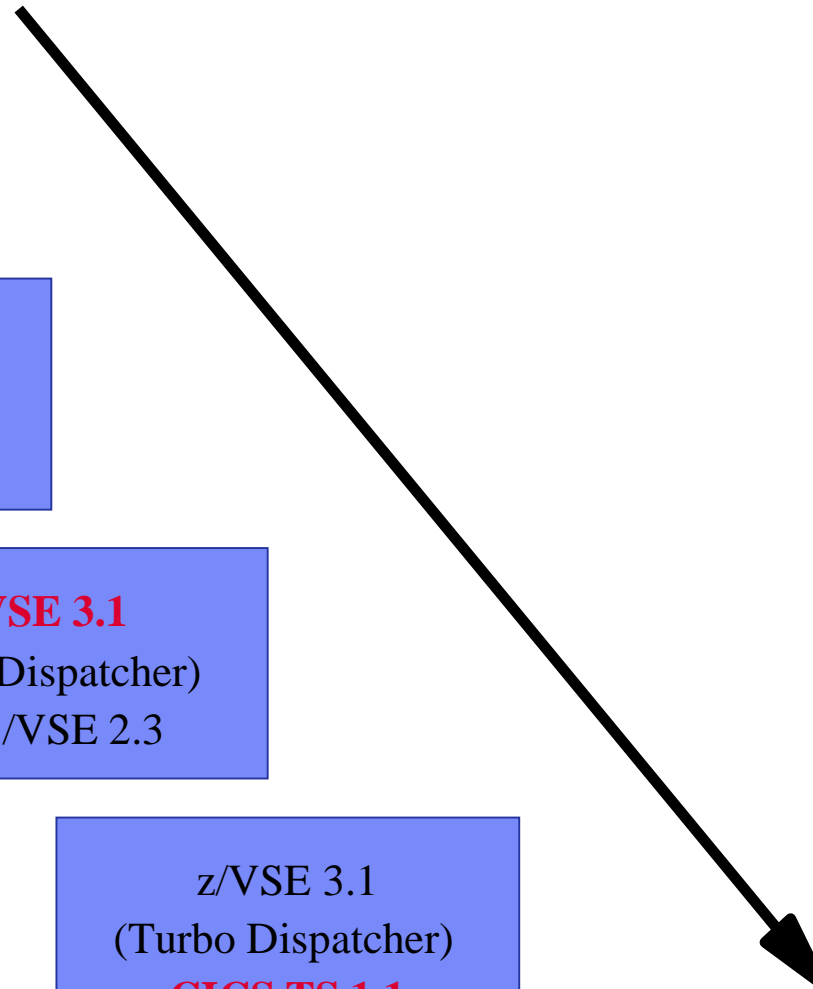

Change only
one thing at a time!

Allows you to see which step
has introduced a problem.

Performance Tips

- § A partition can only exploit **1 CPU** at a time
 - 2 CPUs do not have any benefit for a single CICS partition
 - Use as many partitions as required for selected n-way
- § Use/define only as many CPUs as really needed
 - additional CPUs create more overhead, but no benefit
- § Partitions setup
 - Set up more batch and/or (independent) CICS partitions
 - Split CICS production partitions into multiple partitions (AOR, TOR, FOR)
- § Try to exploit Turbo Dispatcher functions
 - Priority settings
 - Partition balancing
 - Partition balancing groups

Performance Tips (2)

- § 1 CPU must be able to handle **all non-parallel workload**
- § Non-parallel code limits the n-Way exploitation
 - QUERY TD: $NP/TOT = NPS$ (non parallel share)
 - Measure NPS before migration
 - **max CPUs = 0.8 - 0.9 / NPS**

NPS	#CPUs	NPS	#CPUs
0.20	4.0-4.5 (4)	0.45	1.8-2.0 (2)
0.25	3.2-3.6 (3)	0.50	1.6-1.8 (2)
0.30	2.7-3.0 (3)	0.55	1.5-1.6 (2)
0.35	2.3-2.6 (2)	0.60	1.3-1.5 (1)
0.40	2.0-2.2 (2)	0.65	1.2-1.4 (1)

Performance Tips (3)

- § Non-parallel code limits the maximum MP exploitation
- § System code (Key 0) increases non-parallel share
 - Vendor code can have significant impact
- § Overhead increases when NP code limits throughput
- § Data In Memory (DIM) reduces non-parallel code
 - less system calls (I/Os)
 - may increase throughput
 - CICS Shared Data Tables
 - Large/many VSAM Buffers (with buffer hashing)
 - Virtual Disks
- § Change VSE/POWER startup to WORKUNIT=PA
- § Switch tracing/DEBUG off for production

zSeries Remarks – Split cache

- § Prior to zSeries there is one cache for data and instructions
- § zSeries has split data and instruction cache
- § Performance implications:
 - If **program variables** and **code that updates** these program variables are **in the same cache line** (256 byte)
 - Update of program variable invalidates instruction cache
 - Performance decrease if update is done in a loop
 - See APAR PQ66981 for FORTRAN compiler

zSeries Remarks – Split cache – Example

Killer example:

```
*   prepare length
BCTR  R2,0   ADJUST FOR SS-
INSTR.
STC   R2, *+5
MVC   RECEIVER( *-* ), SENDER
```

STC instruction modifies the next instruction to set the length.

Better code:

```
*   prepare length
BCTR  R2,0   ADJUST FOR SS-INSTR.
EX    R2,MVC01
...
MVC01 MVC    RECEIVER( *-* ), SENDER
```

Use EXECUTE instruction instead.

zSeries Performance: Processor Design Considerations:

<http://www.ibm.com/support/techdocs/atmastr.nsf/WebIndex/FLASH10208>

zSeries Remarks – Split cache – Example

Not causing a problem:

```

LA      R1,PHASNAME      POINT AT PHASE NAME
CDDELETE (1)
+*     SUPERVISOR - CDDELETE - 5686-032-06
+     CNOP 0,4
+     BAL 15,*+8
+     DC  A(B'00010010')
+     L 15,0(,15)
+     SVC 65              ISSUE SVC FOR CDDELETE
+     DS 0H
    
```

CDDELETE uses an inline flag byte,
but does not modify it

Can cause a problem:

```

WTO TEXT=DATA
+     CNOP 0,
+     BAL 1,IHB0003A     BRANCH AROUND MESSAGE
+     DC  AL2(8)         TEXT LENGTH
+     DC  B'0000000000010000' MCSFLAGS
+     DC  AL4(0)         MESSAGE TEXT ADDR
+     ...
+IHB0003A DS 0H
+     LR 14,1           FIRST BYTE OF PARM LIST
+     SR 15,15         CLEAR REGISTER 15
+     AH 15,0(1,0)     ADD LENGTH OF TEXT + 4
+     AR 14,15         FIRST BYTE AFTER TEXT
+     LA 15,DATA       LOAD TEXT VALUE
+     ST 15,4(0,1)     STORE ADDR INTO PLIST
+*     SUPERVISOR - SIMSVC - 5686-032
+     ...
+     SVC 35           ISSUE SVC 35
@GE00016 DS 0H
    
```

WTO uses an inline parameter list,
but modifies the parameter list

Note: WTO can be coded with an external
parameter list: WTO ...,MF=(E,addr)

Possible performance issues with PPRC

- § Issue may occur if
 - PPRC is used
 - VSE runs in native or in LPAR
 - Not all devices that are defined in IOCP are also defined in VSE ADD statements

- § In case there is an PPRC state change, interrupts are sent to all LPARs where the related device are defined in IOCP.
 - If the device is defined in VSE ADD, no problem occurs: VSE will process the interrupt correctly.
 - If the device is NOT defined in VSE ADD, the interrupt is ignored by VSE and the interrupt is resent very quickly to that LPAR
 - Results in very high channel activity (up to 100%)

- § Solution:
 - Define ALL devices in VSE ADD that are defined in IOCP

VSE/POWER POFFLOAD Performance Issues

- § Caused by incompatibility between VSE/POWER tape format and new tape drives

- § 3490F empties cache for FSF used by POFFLOAD LOAD
 - Install **DY46164/DY46245** for VSE/ESA 2.7/2.6

- § 3590 synchronizes cache with tape for each WTM
 - Install microcode **FC0520** on A60 controller + VSE/AF **APAR DY45817** + AR command **TAPE WTM=NOSYNC**
 - Unfortunately controller A50 is too small to install FC0520

New POWER POFFLOAD Append function

§ New APPEND option (new with z/VSE 4.1):

- POFFLOAD {BACKUP|SAVE|PICKUP},
queue, tapeaddr, density, class, APPEND...
- WAVV requirement WAVV200433
- Requires 3592 tape unit

§ Great performance benefit when using 3592 tape unit:

- Spool time dramatically reduced when using 3592 tape unit (spool time cut half)
- No wasting of time for skipping existing spool entries on tape when APPENDING using “Space End of Data” command

Tape unit	Search for End-Of-Data to begin APPENDING new Offload Entries	Time to Spool 206 new entries at End-of-data
3592	About 1 second	102 seconds
2490E	307 seconds (not supported)	204 seconds

VTAM 31 Bit I/O Buffer Support

§ VSE/VTAM is providing new 31 bit IO buffer support via PTF

- Removes the 24 bit I/O buffer restriction.
- Moves the **I/O buffer pool** and **all I/O CTC packing buffers** above the 24 bit line
- Support I/O operations in 31 bit mode (using format 1 CCWs).
- Allow z/VSE customers to grow their communications workloads associated with their business critical applications

§ PTFs

- VTAM support - APAR DY46471 - PTF UD52964
- z/VSE support - APAR DY46396 - PTF UD52873 (AF Base) or PTF UD52874 (Generation Feature)

VTAM 31 Bit I/O Buffer Support

§ To enable the 31 Bit support:

- Make sure both PTFs (VTAM and AF) are applied
- Set VTAM start option **IOBUF31=YES** (default is NO)

§ Display settings

```
d net,vtamopts,opt=iobuf31
AR 0015 1C39I COMMAND PASSED TO ACF/VTAM
F3 0003 IST097I DISPLAY ACCEPTED
F3 0003 IST1188I ACF/VTAM V4R2 STARTED AT 17:11:29 ON 11/11/05
F3 0003 IST1349I COMPONENT ID IS 5686-06501-FE6
F3 0003 IST1348I VTAM STARTED AS INTERCHANGE NODE
F3 0003 IST1497I VTAM FUNCTIONAL SUPPORT LEVEL IS INTERENTERPRISE
F3 0003 IST1189I IOBUF31 = YES
F3 0003 IST314I END
```

Documentation

- § z/VSE homepage:
 - <http://www.ibm.com/servers/eserver/zseries/zvse/>
- § VSE Performance:
 - <http://www.ibm.com/servers/eserver/zseries/zvse/documentation/performance.html>
- § z/VM homepage:
 - <http://www.ibm.com/vm>
- § z/VM Performance:
 - <http://www.vm.ibm.com/perf/>
- § z/VM Preferred Guest Migration Considerations
 - <http://www.vm.ibm.com/perf/tips/z890.html>
- § IBM System z9 and eServer zSeries Software Pricing
 - <http://www.ibm.com/servers/eserver/zseries/swprice/>
- § IBM's MSU ratings for the z9 Servers
 - <http://www.ibm.com/servers/eserver/zseries/library/swpriceinfo/hardware.html>

Questions ?

