



**E43**

**z/VSE 3.1.0**

**Ingolf Salm**

**zSeries® EXPO**

**FEATURING Z/OS, Z/VM, Z/VSE  
AND LINUX ON ZSERIES**

**September 19 - 23, 2005**

**San Francisco, CA**

# Trademarks

The following are trademarks of the International Business Machines Corporation in the United States and / or other countries.

AIX	IBM*	VSE/ESA
CICS*	IBM logo*	VTAM*
DB2*	IMS	WebSphere*
DB2 Connect	Multiprise*	iSeries
DB2 Universal Database	MQSeries*	pSeries
e-business logo*	OS/390*	xSeries
Enterprise Storage Server	S/390*	z/Architecture
FlashCopy*		z/OS
HiperSockets		z/VM
		z/VSE
		zSeries

\* Registered trademarks of IBM Corporation

The following are trademarks or registered trademarks of other companies.

LINUX is a registered trademark of Linus Torvalds

Java and all Java-related trademarks and logos are trademarks of Sun Microsystems, Inc., in the United States and other countries

UNIX is a registered trademark of The Open Group in the United States and other countries.

Microsoft, Windows and Windows XP are registered trademarks of Microsoft Corporation.

SET and Secure Electronic Transaction are trademarks owned by SET Secure Electronic Transaction LLC.

Intel is a registered trademark of Intel Corporation.

# Agenda

2005 marks the 40th anniversary of  
**IBM System/360 Disk Operating System (DOS/360)**  
the forerunner of today's z/VSE.

- Roadmap
- VSE strategy
- VSE e-business connectors
- z/VSE 3.1
  - Exploitation of
    - SCSI disks
    - zSeries processors
    - IBM TotalStorage devices
- Documentation

# VSE/ESA Roadmap

Quality

Connectivity  
(e-business enablement)

z/OS Affinity

Capacity

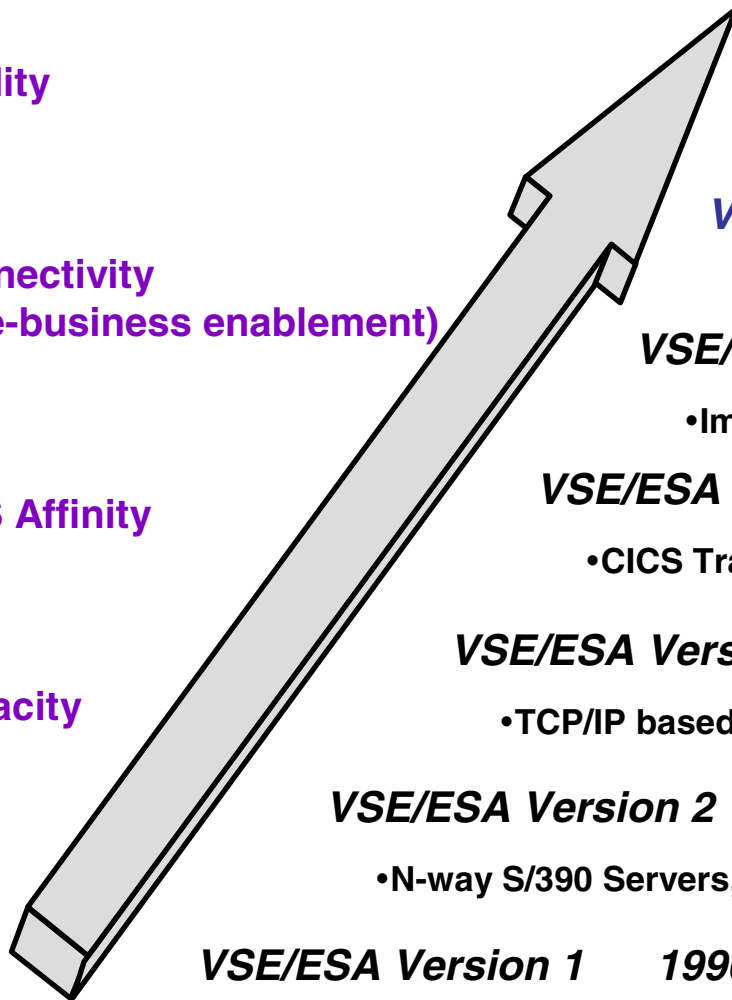

***z/VSE 3.1***    ***March 2005***

- Focus on zSeries and infrastructure simplification

***VSE/ESA V2.7***    ***March 2003***

- Extends interoperability, e.g. to Linux on zSeries

***VSE/ESA V2.6***    ***December 2001***

- Interoperability continued

***VSE/ESA V2.5***    ***September 2000***

- Improved Interoperability

***VSE/ESA V2.4***    ***June 1999***

- CICS Transaction Server for VSE/ESA, *e-business*

***VSE/ESA Version 2.3***    ***1997***

- TCP/IP based communication

***VSE/ESA Version 2***    ***1994***

- N-way S/390 Servers, Investment Protection - Year 2000

***VSE/ESA Version 1***    ***1990***

- Constraint Relief, ESA exploitation

# VSE Strategy

- Helps **Protect** your existing investments in core VSE programs, data, equipment, IT skills, *plus* business processes, end user training, etc.
  - modernize, i.e. extend VSE resources to Web
  - exploit IBM servers, storage, and software
- **Integrate** VSE with the rest of your IT based on open and industry standards
  - IBM middleware
  - VSE connectors and web services
- **Extend** with Linux on zSeries
  - infrastructure consolidation/simplification
  - add new infrastructure and/or line-of-business applications

## Why Not Think Inside the Box?

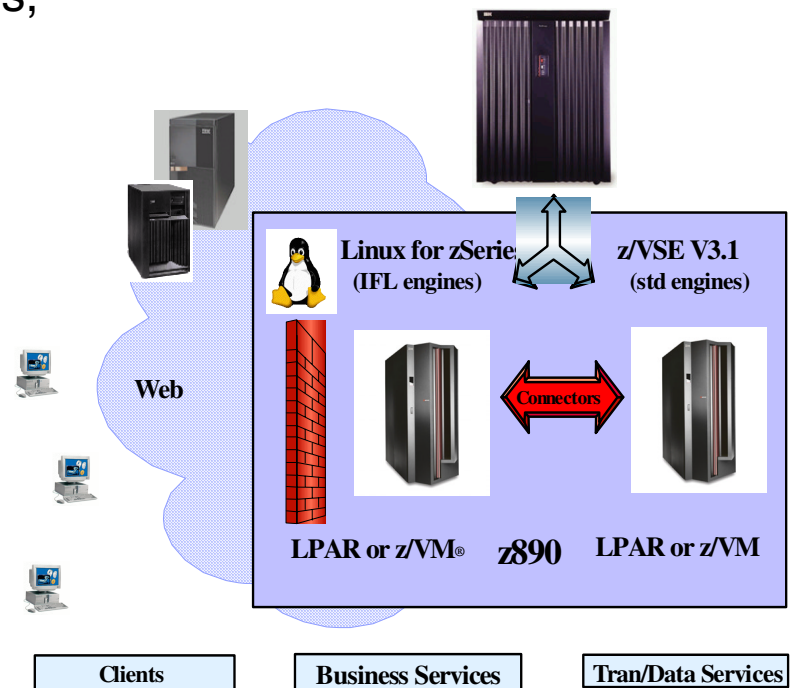

## z/VSE <sup>(1)</sup> 3.1

- Helps **Protect** investments in your core VSE assets
  - **Fibre Channel Protocol (FCP) Channel attached SCSI disk**
  - HiperSockets, incl spanned HiperSockets
  - PCICA hardware encryption assist
  - Adapter interrupts for OSA-Express
  - OSA-Express, incl Ethernet and Token Ring
  - OSA-Integrated Console Controller
  - Up to 30 LPARs
  - Up to 2 LCSSs on z890 - 4 on z990
  - FICON-Express
- **Integrate** VSE with the rest of your IT
  - VSE Connectors and web services
  - IBM middleware
- **Extend** with Linux on zSeries

Note 1: z/VSE can operate in 31-bit mode only. It does not implement z/Architecture and specifically does not implement 64-bit mode capabilities. z/VSE is designed to support selected features of IBM zSeries hardware

# Customer Application Portfolio:

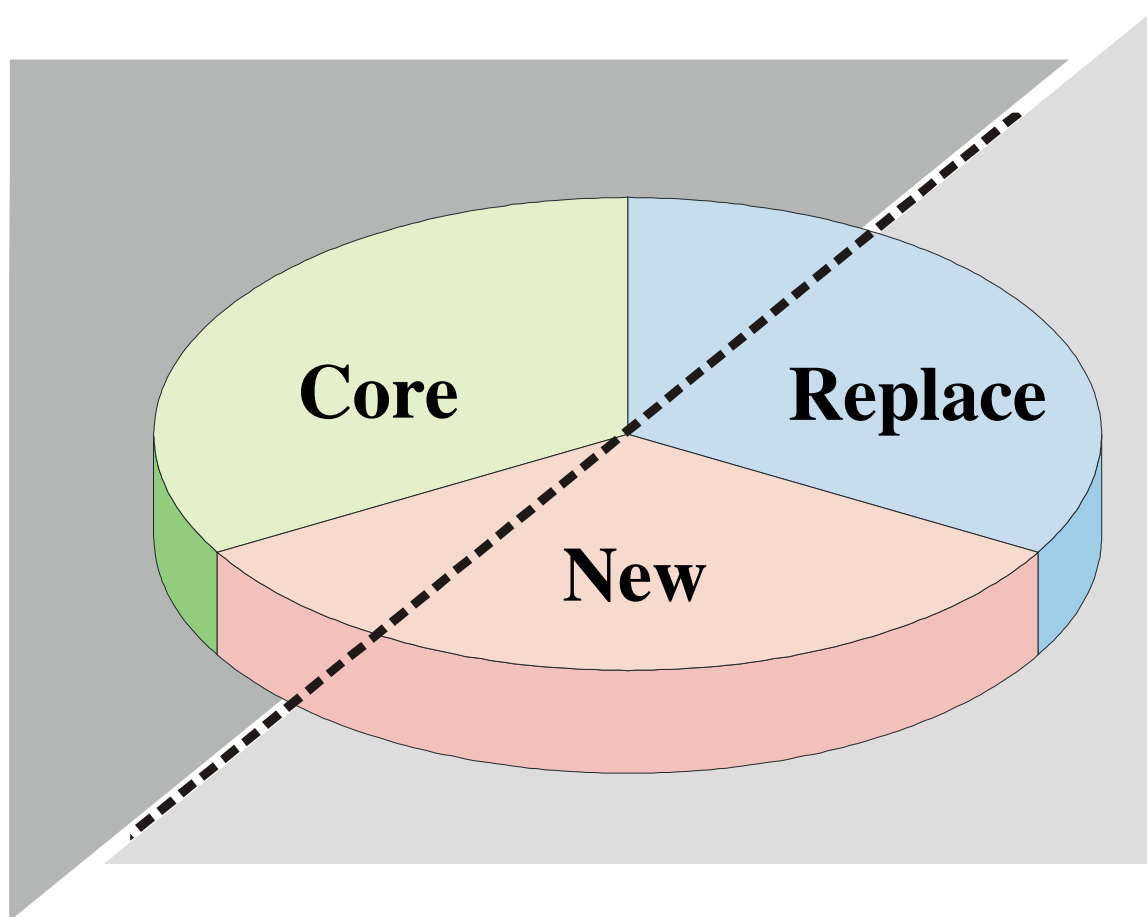

# Integrating Hybrid Environments

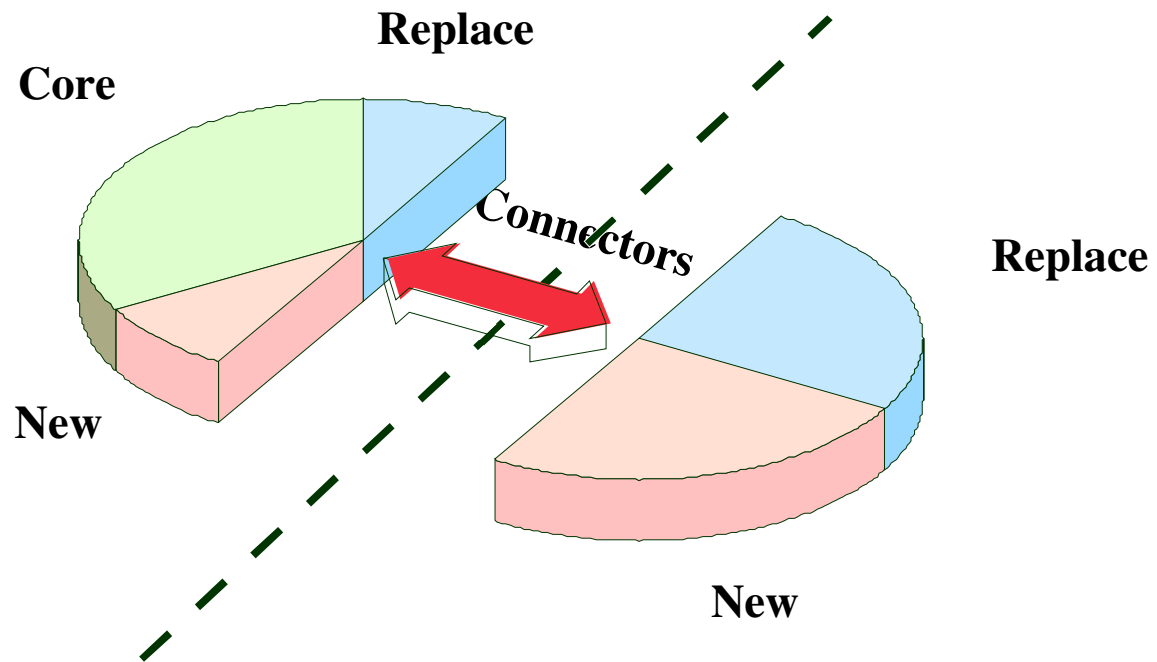



# VSE e-business Connectors

(introduced with VSE/ESA 2.5)

- Easy access to VSE/ESA resources from other systems
  
- VSE e-business connectors include
  - Server code running on VSE/ESA
  - JAVA beans, servlets and samples on Java capable clients
    - Such as IBM's WebSphere Application Server
    - which may run on Windows, Linux, AIX, z/OS, ...
  
- Advantages
  - Exploitation of non-VSE e-business infrastructure
  - Always newest e-business components
    - Java, web server, security
    - Platform independent
  - VSE/ESA resources can be easily integrated into new e-business applications
    - VSE e-business connectors
    - Other IBM connectors (DB2 Connect, MQ Series client, CICS TS Gateway, ...)

# VSE/ESA e-business Connectors ...

- DB2 based connectors for VSAM and DL/I
  - Exploitation of DB2 infrastructure  
(JDBC/ODBC, DB2 Connect, DB2 server, DB2 stored procedures)
  - Mapping of SQL requests to VSAM and DL/I data
  - Sample mappings and applications provided
  - Communication via DRDA (SNA or TCP/IP based with DB2 V7)
  
- External services based VSE connectors
  - Access to VSE/ESA resources, such as  
VSE/VSAM files, VSE/POWER, VSE/ICCF, VSE Librarian, VSE console,  
DL/1, JDBC to VSAM, VSE Print
  - Access provided via
    - external services running on VSE/ESA
    - Java-based services running on  
e.g. web application server environments
  - Java samples are provided
  - Communication TCP/IP based

# VSAM Redirector

(introduced with VSE/ESA 2.6)

- VSAM Redirector provides
  - Access to remote data
    - on Java capable platform (e.g.Linux on zSeries)
    - transparent to VSE/ESA program (batch or online)
  - Samples to access flat files and DB2 UDB
  - Interfaces to include other data
  - Communication to other platform via TCP/IP

➔VSE/ESA as a client

# VSAM Redirector...

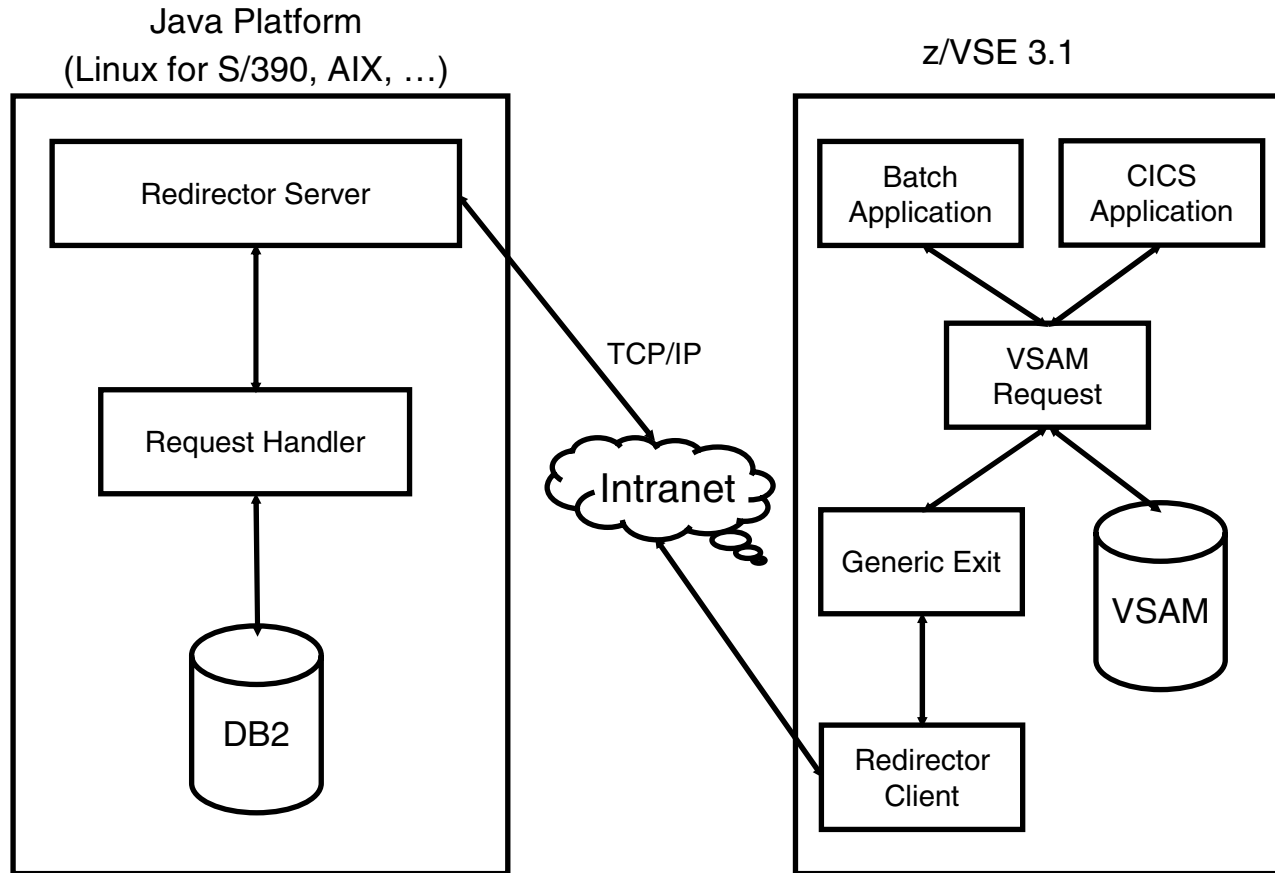

# Virtual Tape

(introduced with VSE/ESA 2.6)

- File or dataset containing a tape image, that is
  - VSE/VSAM ESDS file on VSE/ESA
  - Remote file on Java-capable server platform (Windows, Linux, ...)
  
- Has most functions of physical tape
  - Some functions not supported  
e.g. SDAID to tape, Ditto Erase function
  
- "virtual tape" device need to be ADDED at IPL
  
- New VTAPE command to manage virtual tapes

# Virtual Tape ...

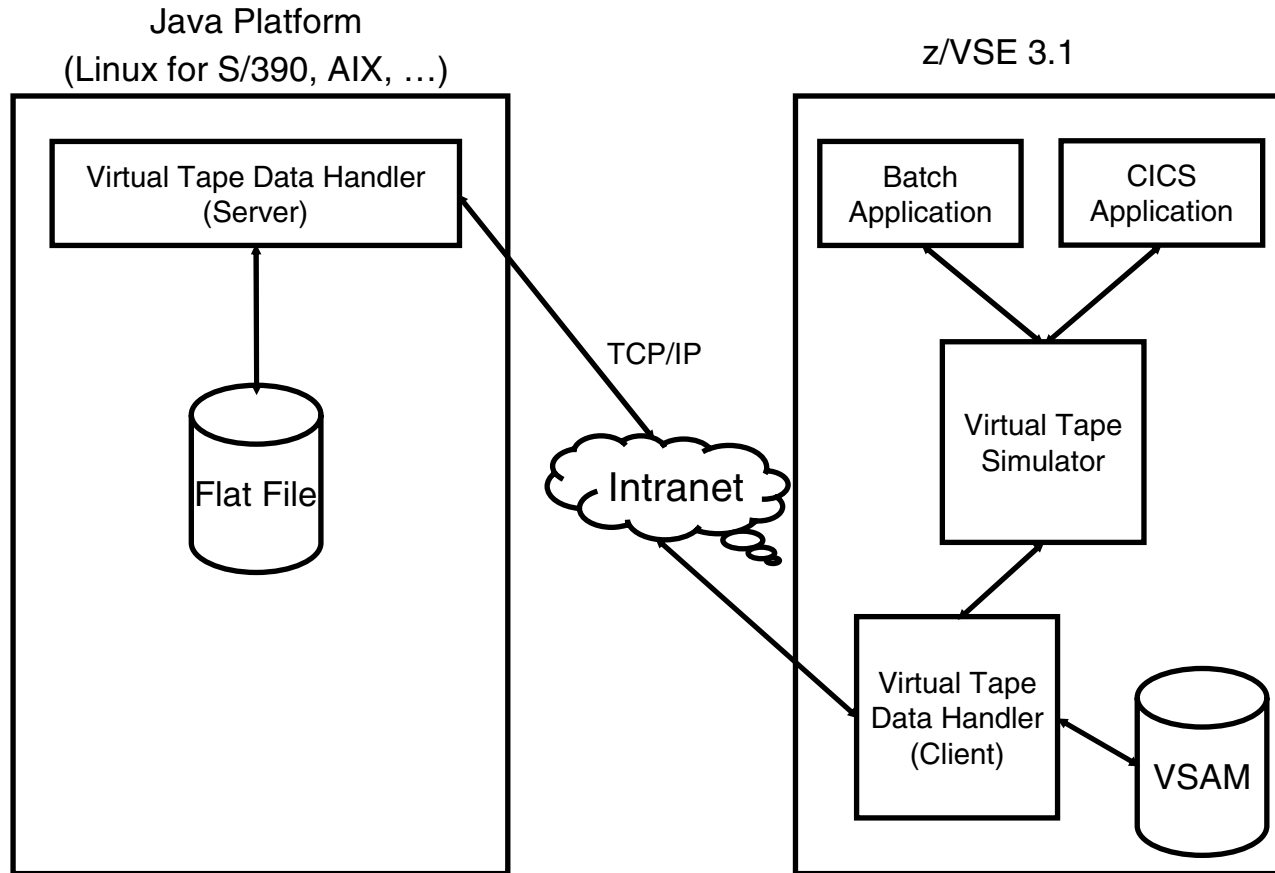

# Web Services

(introduced with VSE/ESA 2.7)

- Enhanced interoperability through
  - Simple Object Access Protocol (SOAP)
    - information exchange over the internet (e.g. with CICS appls)
    - VSE/ESA SOAP server/client
      - implemented as CICS program using CICS Web Support (CWS)
    - Any SOAP enabled platform may call a web service running as a CICS application
    - SOAP based on XML
  - Extensible Markup Language (XML)
    - creation and parsing XML data streams from VSE applications
    - Can be called from batch and CICS applications

# z/VSE e-business Connectors ...

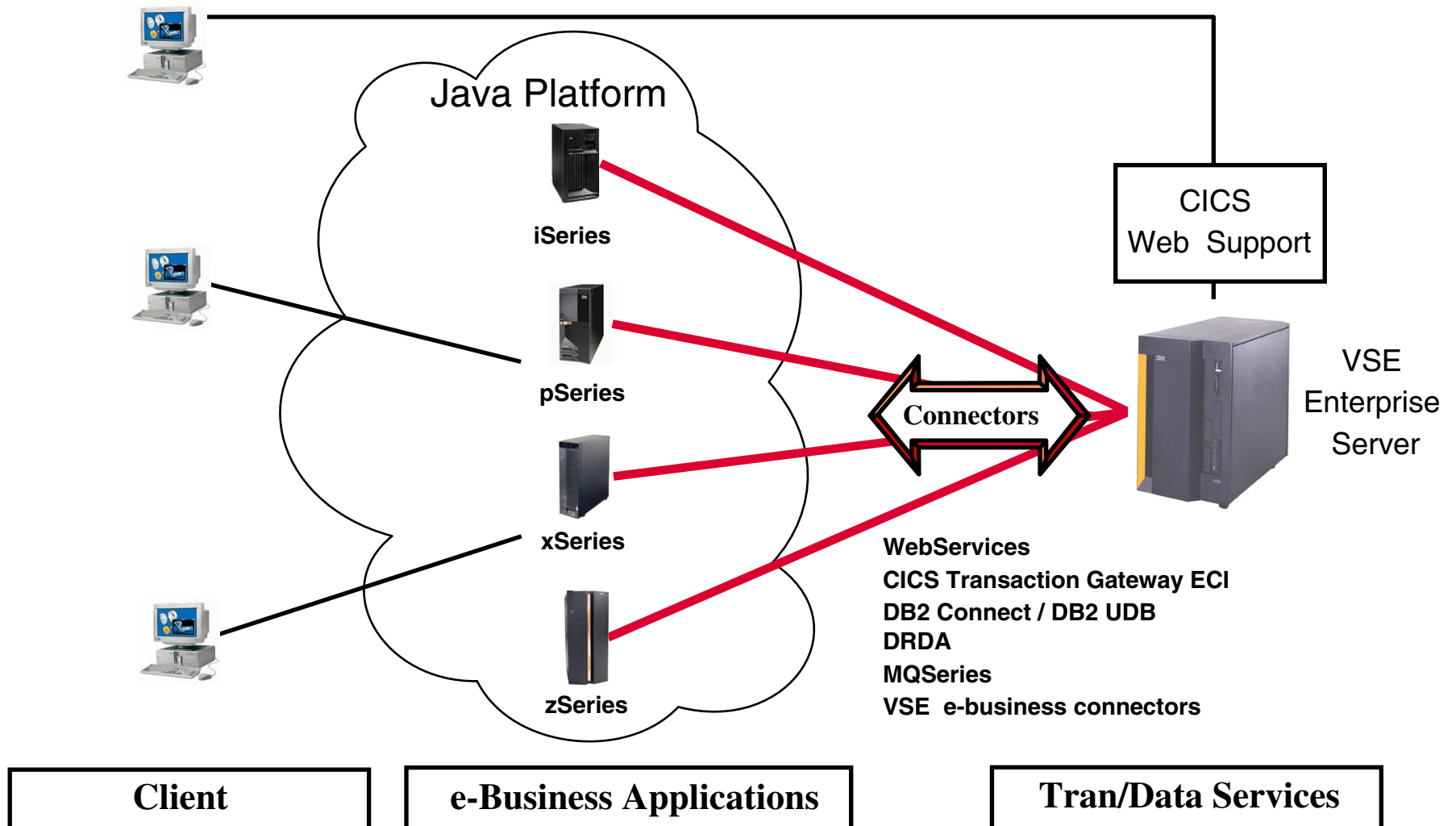



# Internet Security

(introduced with VSE/ESA 2.6)

- Secured TCP/IP connections through SSL encryption services
  - Includes Data Encryption Standard (DES) and triple-DES
  - Licensed from Connectivity Systems Incorporated (CSI)
- SSL API can be exploited by any applications
  - Compatible with the z/OS SSL API
- SSL exploiters: TN3270, HTTP server, TCP/IP EZA API, CICS web support, VSE connectors, VSE/Power PNET, MQ Series 2.1.1 or higher

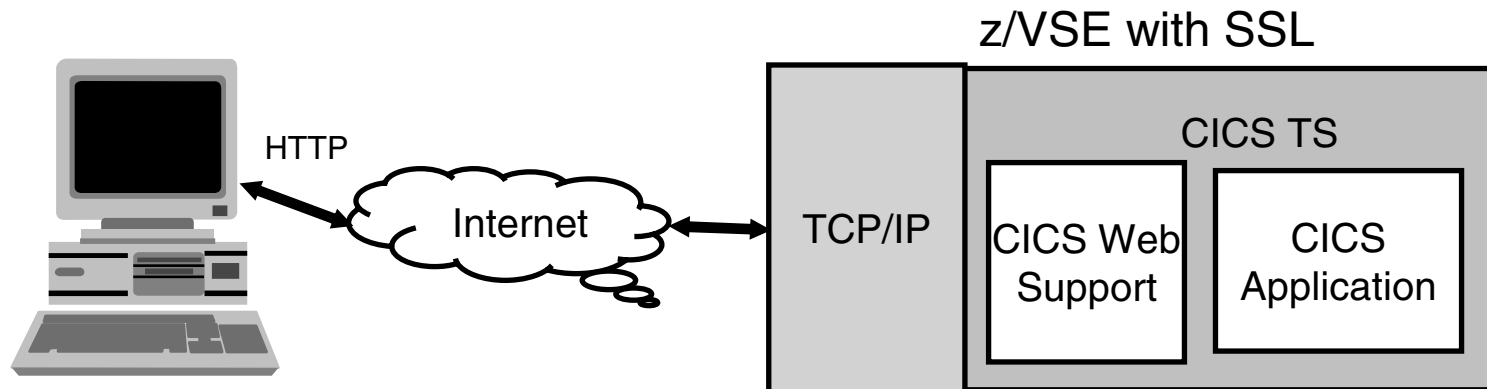

# Internet Security ...

- Hardware cryptographic support with VSE/ESA 2.7 or higher
  - Enhances Internet security
  - Encryption hardware assist for increased SSL throughput
    - Exploits PCI Cryptographic Accelerator (PCICA) card
  - Supports SSL handshaking only
    - for applications that use the SSL crypto API
  - Transparent for TCP/IP applications
    - (VSE connector server, CWS, VSE/Power PNET)
  - No definition necessary

# Internet Security ...

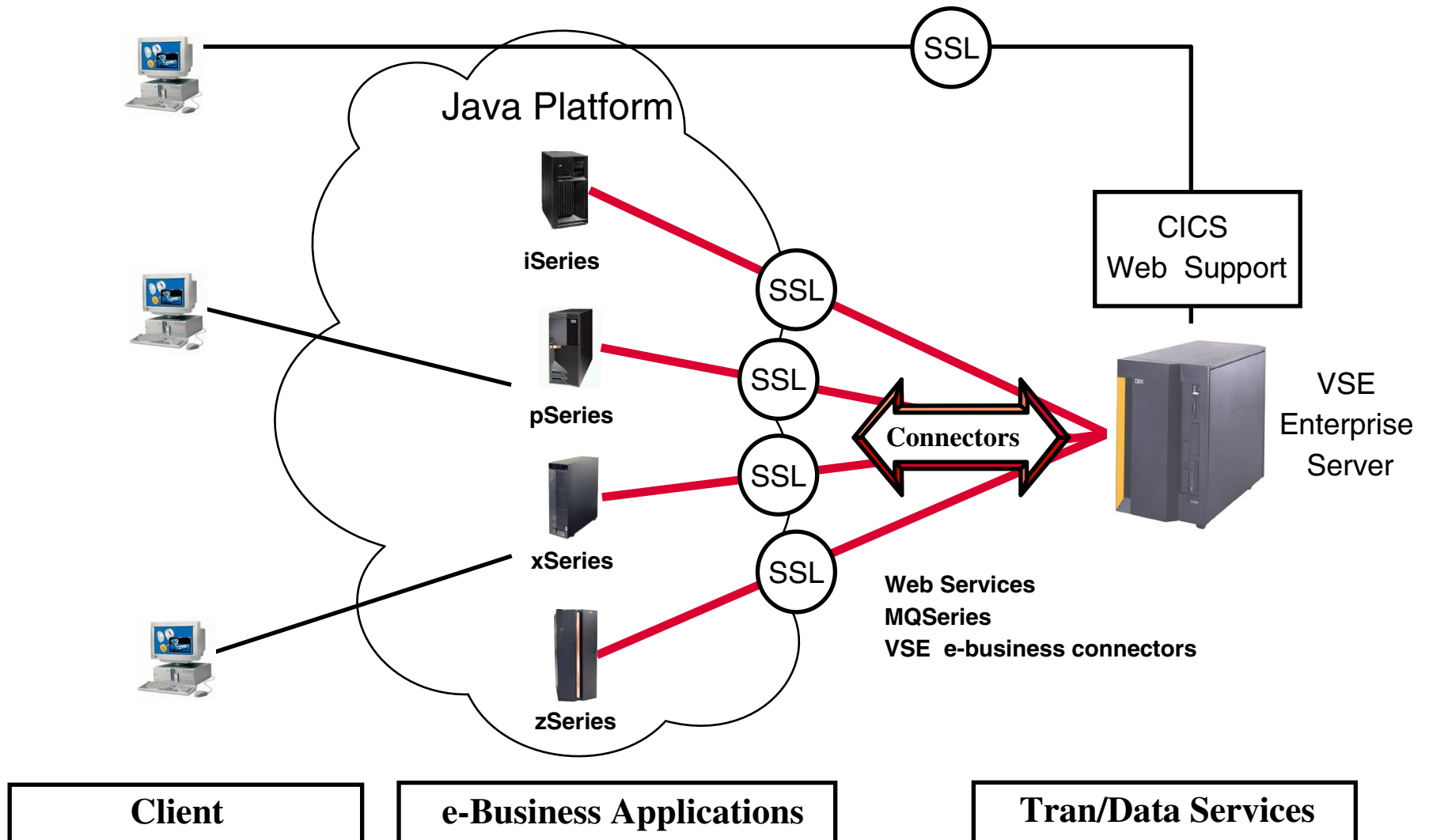

# zSeries HiperSockets

(introduced with VSE/ESA 2.7)

- zSeries HiperSockets
  - “network in the box”,  
TCP/IP based communication at near memory speed within one system
    - zSeries Logical Partitions (LPARs)
    - z/VM guests (via virtual guest LAN)
    - z/VM guests and LPARs
  - z/VSE 3.1 may communicate with
    - Linux on zSeries
    - z/OS
    - z/VM
    - VSE/ESA 2.7 or z/VSE 3.1
  - Virtual HiperSockets available on S/390 processors  
via z/VM Guest LAN support (z/VM 4.2 or higher)
  - Implemented as device driver (owned by IBM) for the TCP/IP stack

# HiperSockets Example

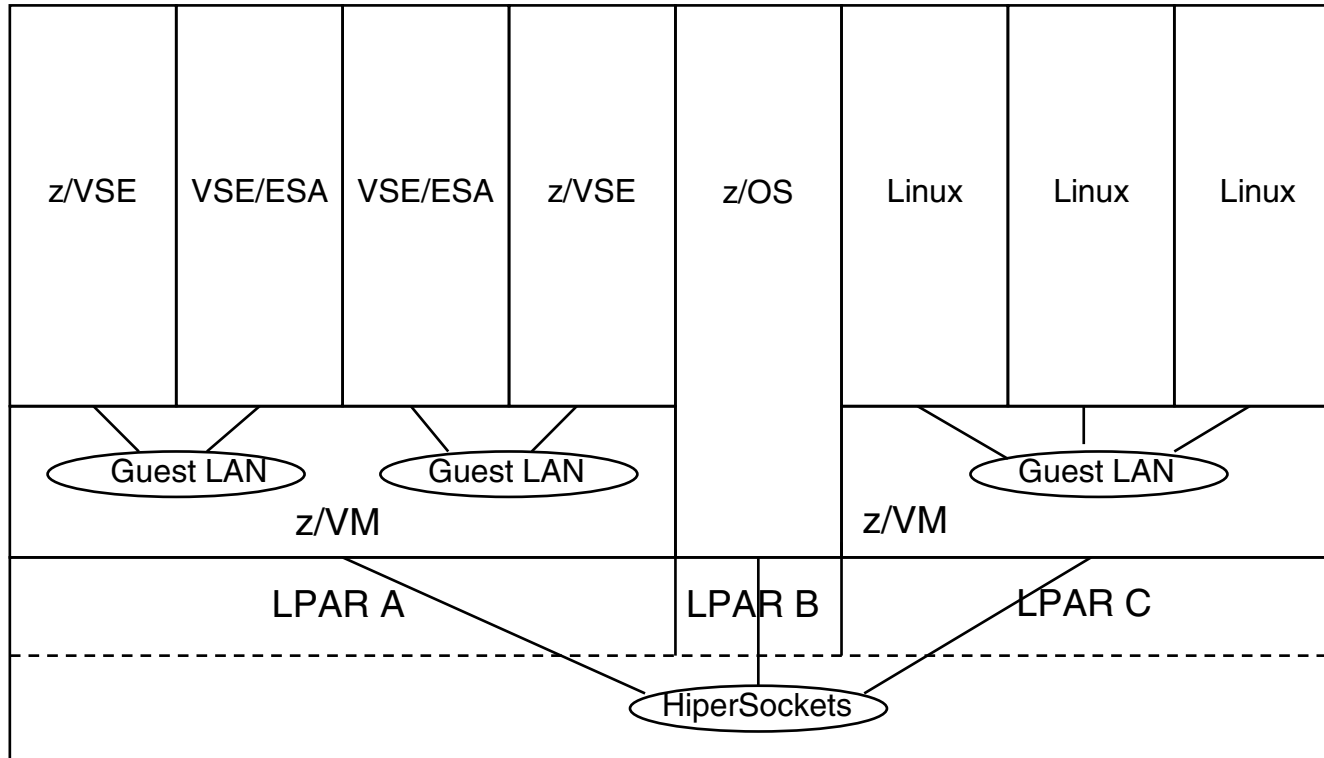

# z/VSE (Hw Crypto + HiperSockets)

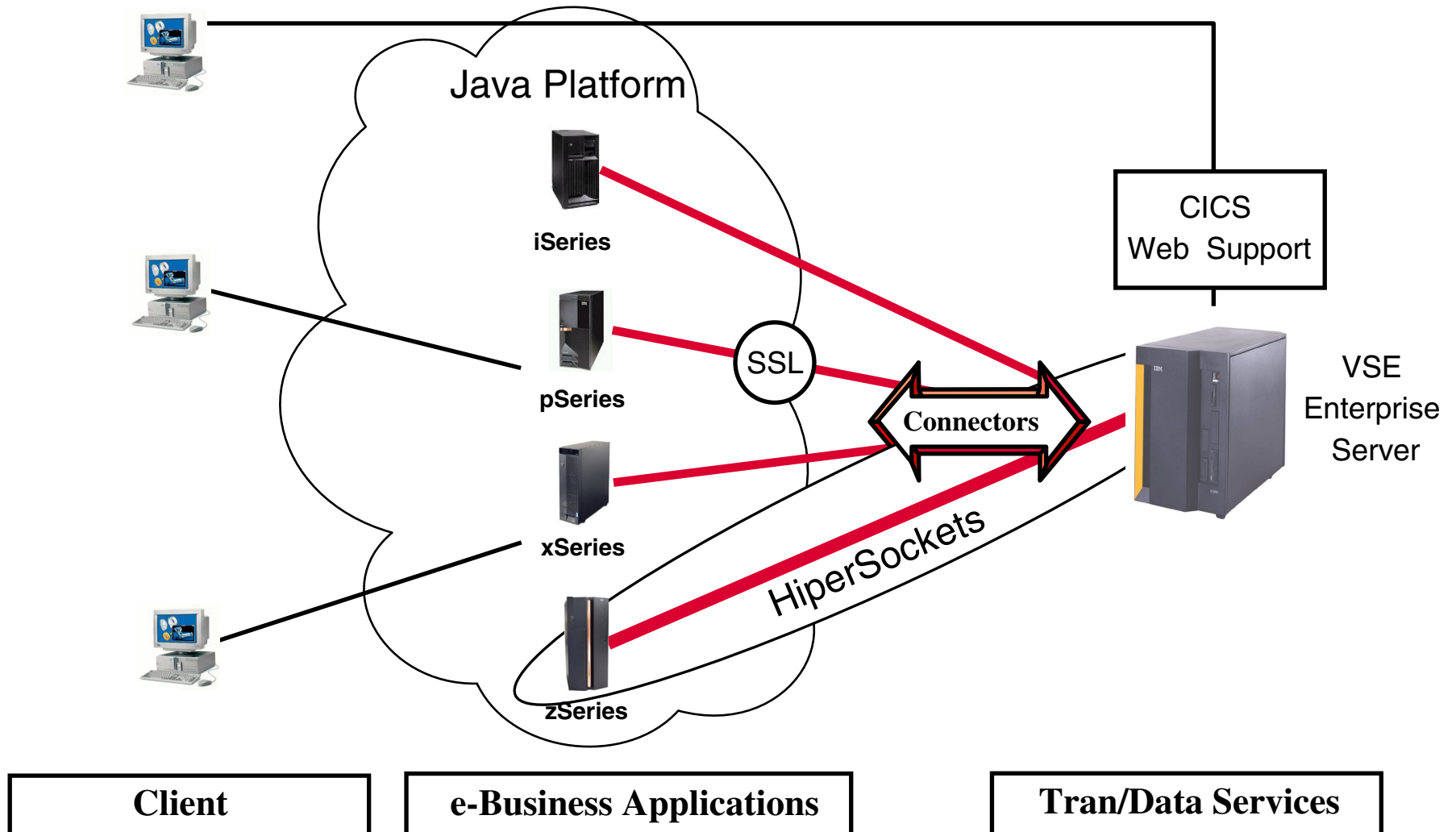

# z/VSE 3.1

- Schedules
  - 4/7/2004 – Previewed
  - 2/1/2005 - Announced
  - 3/4/2005 - GA
- Support of Small Computer System Interface (SCSI) devices
- Expand focus on interoperability
  - Especially with Linux on zSeries
- Simplified packaging
  - Language Environment as part of VSE Central Function
- Options for electronic internet delivery and CD-ROM shipment
- z/VSE can execute in 31-bit mode only
- FSU from VSE/ESA 2.6, 2.7 (ECKD devices)

# Supported z/VSE Environments

- z/VSE 3.1 runs on ESA/390 and zSeries hardware only
  - ... and supports
    - S/390 Multiprise 3000
    - S/390 Parallel Enterprise Server G5, G6
    - IBM e-server zSeries processors (z800, z900, z890, z990)
    - Equivalent processors based on G5 architecture
    - Linux on zSeries, z/VM V4.x support same architecture level
  
- Turbo Dispatcher only
  - On all uni- and multiprocessors
  - Native, as z/VM guest or in LPAR



# SCSI Support for z/VSE

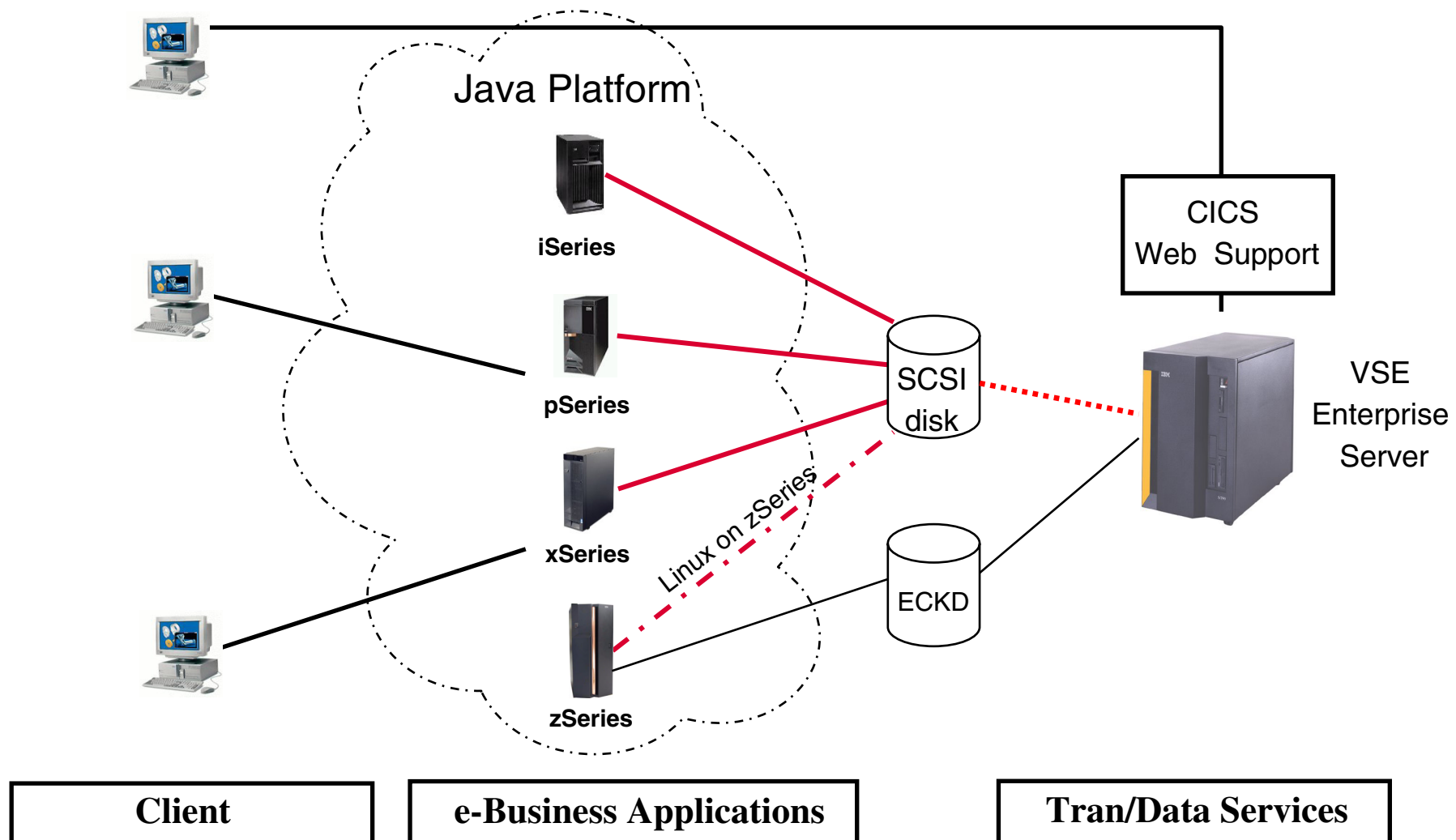

# Overview - Supported SCSI Environments

- SCSI disks as emulated FBA disks on z/VM 5.1
  - z/VSE supports a max. size of 2 GB
- Direct attached SCSI disks
  - z/VSE supports up to 24 GB (VSAM: 16 GB)

# Overview - SCSI Support in z/VSE

- z/VSE supports SCSI disk devices only
- Impact on applications
  - Transparent to all VSE applications and subsystems,
    - Minimal impact on ISV system management tools
  - Reasons for transparency:
    - z/VSE's SCSI implementation is based on FBA support
    - Applications can not exploit SCSI commands directly
    - FBA to SCSI emulation on low level I/O interface

# SCSI Support in z/VSE

- Access SCSI devices through Fibre Channel Protocol (FCP)
  - Support available on zSeries processors
  - OS interfaces
    - Operating system communicates with FCP adapter
    - FCP adapter communicates with the SCSI device
  - SCSI disk devices utilize fixed block sectors
    - Therefore VSE treats them as FBA devices

# Overview - SCSI Support – Content / Limitations

- z/VSE's SCSI support includes:
  - SCSI for system and data device (SCSI only system)
  - Multipathing for fail-over
- Minimum processor storage: 32 MB
- SCSI support transparent to existing (I/O) APIs
- Block size restricted to 512 bytes, even if the SCSI device can be configured with larger block sizes
- Max. SCSI disk size about 24 GB, VSAM 16 GB
- FSU from VSE/ESA 2.6, 2.7 to SCSI device is not possible

# Overview - SCSI Support - Configuration

- New IPL / JCL commands and dialog to define and query a SCSI device
- Required steps to get a SCSI device known to z/VSE
  - Device /Switch configuration
  - FCP Adapter to be configured in IOCDS (CHIPID type FCP)
  - FCP adapter and SCSI disk to be defined in VSE via
    - IPL ADD commands to define FCP and FBA device
    - IPL DEF or JCL SYSDEF command to define connection to LUN

# SCSI Support - Configuration

- zSeries FCP adapter supports switched network only:
  - Each FCP adapter has an associated port (WWPN)
  - FCP adapter configured in IOCDs with subchannel type FCP
  - FCP adapter connects to a switch
  - Switch connects to a controller with one or multiple ports
  - Controller accesses one or more SCSI devices (LUNs)

# SCSI Support - Configuration

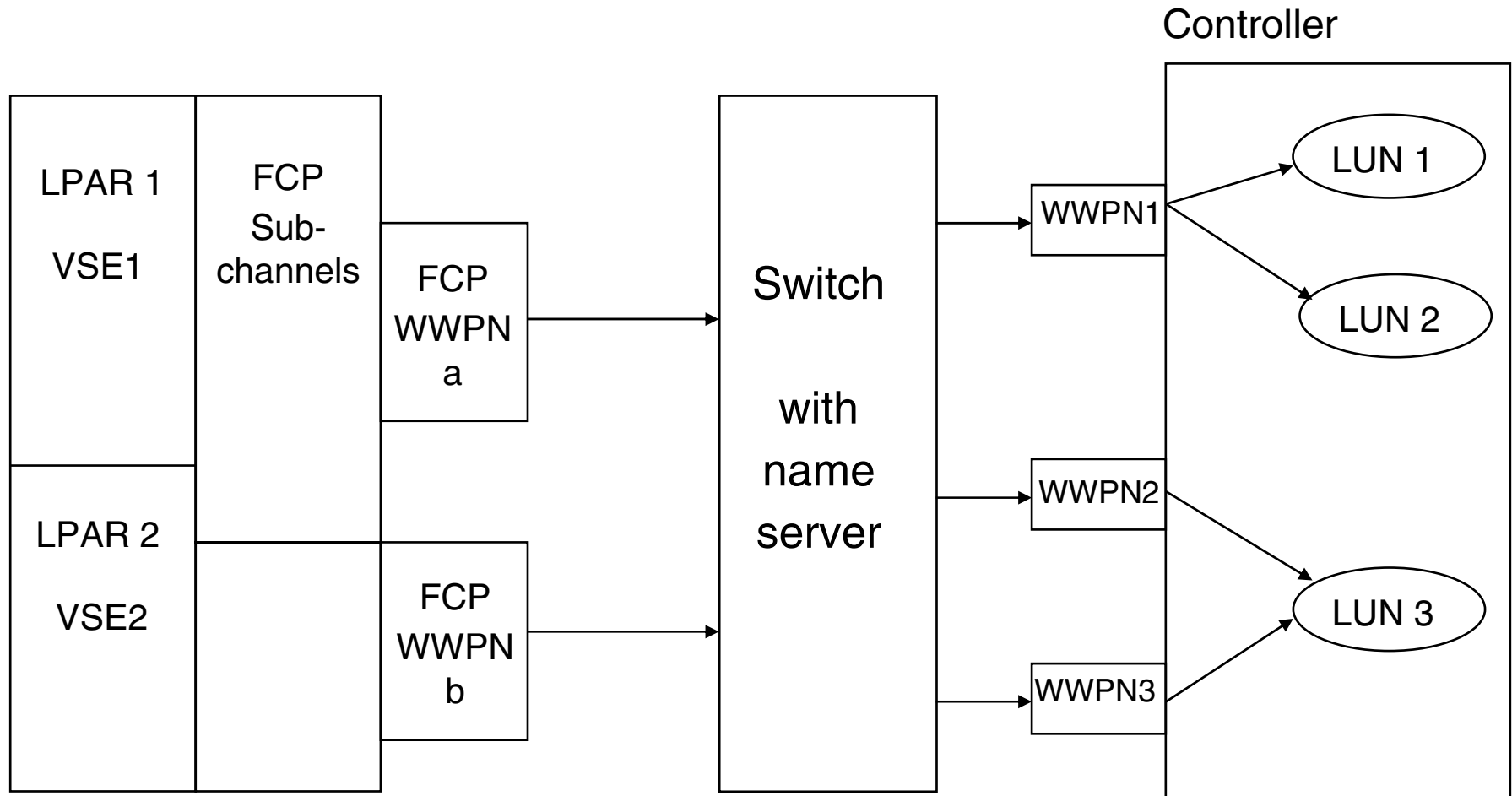



# zSeries Exploitation

- OSA Express2 – new generation of zSeries LAN adapters
  - 10 Gigabit Ethernet
  - Gigabit Ethernet
- HiperSockets
  - Spanned channels – across different LCSSs
- Spanned external channels
  - FICON Express2 / Express, OSA Express 2 / Express adapters across multiple LCSSs
- FICON Express 2 / Express
  - Higher I/O bandwidth
- Adapter interruptions
  - Performance improvements can be expected for OSA Express2/Express (QDIO mode), FICON Express2/Express (FCP)
- OSA Express Integrated Console Controller (OSA-ICC)
  - May eliminate the need for non-SNA 3174 controllers or replace existing 3174 and 2074 controllers

# zSeries Exploitation ...

- Cryptographic assists - Exploited by TCP/IP SSL support transparently
  - CPACF – for symmetric encryption
  - PCICA (crypto card) – for asymmetric encryption
  - Crypto Express2 – for asymmetric encryption
    - Only PCICA function supported
    - Will be support via PTF at a later time
- Up to 30 LPARs
- Up to 4 LCSSs
  - z890 supports up to 2 LCSSs, z990 up to 4 LCSSs

## VSE Support for z800 and z890

VSE Version and Release	z800	z890	VSE EoS
<b>z/VSE V3.1</b>	<b>Yes (2)</b>	<b>Yes (2)</b>	<b>tbd</b>
VSE/ESA V2.7	Yes (2)	Yes (2)	tbd
VSE/ESA V2.6	Yes (2)	Yes (2)	03/2006
<b>VSE/ESA V2.5</b>	<b>Yes (2)</b>	<b>No</b>	<b>12/2003</b>
<b>VSE/ESA V2.4</b>	<b>Yes (2)</b>	<b><u>No</u></b>	<b>06/2002</b>
<b>VSE/ESA V2.3</b>	<b>No</b>	<b><u>No</u></b>	<b>12/2001</b>

Note 1: z/VSE can operate in 31-bit mode only. It does not implement z/Architecture and specifically does not implement 64-bit mode capabilities. z/VSE is designed to support selected features of IBM zSeries hardware

Note 2: 31-bit mode only

# Exploitation of IBM TotalStorage Products

- IBM TotalStorage 3494 Virtual Tape Server (3494 VTS)
  - 3494 Tape Library supports 3490E, 3590, 3592 tape drives and 3592 WORM media
  - Support through S/390 channel command interface via
    - Perform Subsystem Function (PSF)
    - Perform Library Function (PLF) commands
- IBM TotalStorage 3592 Enterprise Tape Drive J1A
  - High capacity, fast access media (300 GB / 60 GB cartridges)
  - Cartridges in WORM format for long-term records retention

# Exploitation of IBM TotalStorage Products

- IBM TotalStorage Servers
  - Via ESCON (not DS6000), FICON, FCP channels
  - IBM TotalStorage Enterprise Storage Servers (ESS)
  - DS6000, DS8000
    - (PTF may be necessary; SCSI disks supported at a later time)
- Exploited features
  - Improved FlashCopy – NOCOPY option
    - direct copy to backup device
  - FlashCopy Version 2
    - Datasetcopy – should not be used for VSAM files
    - Elimination of Logical Subsystems
      - Source and target volume can span LSS
    - Multiple relationship FlashCopy
      - Allow to create up to 12 volumes from one source in a single FlashCopy operation
  - Peer-to Peer Remote Copy (PPRC) Version 2
    - Allows remote data replication
    - Supported via ICKDSF

# z/VSE 3.1 base and optional products

- IBM High Level Assembler for z/OS, z/VM, and z/VSE V1.5 (HLASM)
- IBM DB2 Server for VSE and VM V7.4
- CICS Transaction Server for VSE/ESA V1.1.1
  - CICS/VSE shipped with CICS TS
- MQSeries for VSE V2.1.2
  - MQSeries bridge
    - Non-CICS applications may run a CICS program
  - Extended MQI function
    - Synchpoint control support of MQGET, MQPUT, MQPUTI
  - Message transmission between MQSeries queue managers
  - Extended system administration

# z/VSE 3.1 Components

- Language Environment (LE/VSE)
  - Now component of VSE Central Function V7
  - Improvements to storage issues and messages
  - LE/VSE GETVIS usage monitor
  - Improved trace and problem determination
- Connectors support newest platforms
- VSE/POWER enhancements
  - Queue/data file migration during warmstart
  - Data file extension by 'n' extends possible during warmstart

# z/VSE 3.1 Components ...

- Virtual Tape (VTAPE) enhancements
  - Zipped AWSTAPE (.zip)
    - One or more tape images can be included into one PKZIP file
  - Binary PTF data (.ptf)
    - Can be used directly with the PTF apply dialogs
  - Zipped PTF data
    - Can reside in a ZIP file
- Job Control Enhancements
  - System logical units can be assign to disk in dynamic partitions
- Librarian enhancements
  - New DATE operand
    - Controls setting of time stamps for LIBR COPY and MOVE
  - New SORT operand
    - Allows sorting of LIBR LISTDIR SDL output – by phase name or location



## z/VSE 3.1 Components ...

- SDAID enhancements
  - Enlarged wrap buffer, moved to SVA (31 bit)
  - New trace to track locking/unlocking of resources
- WTOR security
  - Routing code 9
    - Secure information no longer shown on console or hardcopy file
- New predefined environment 'C'
  - Large environment of 2GB VSIZE can be selected at initial installation

# z/VSE 3.1 (Hw Crypto + HiperSockets + SCSI disks)

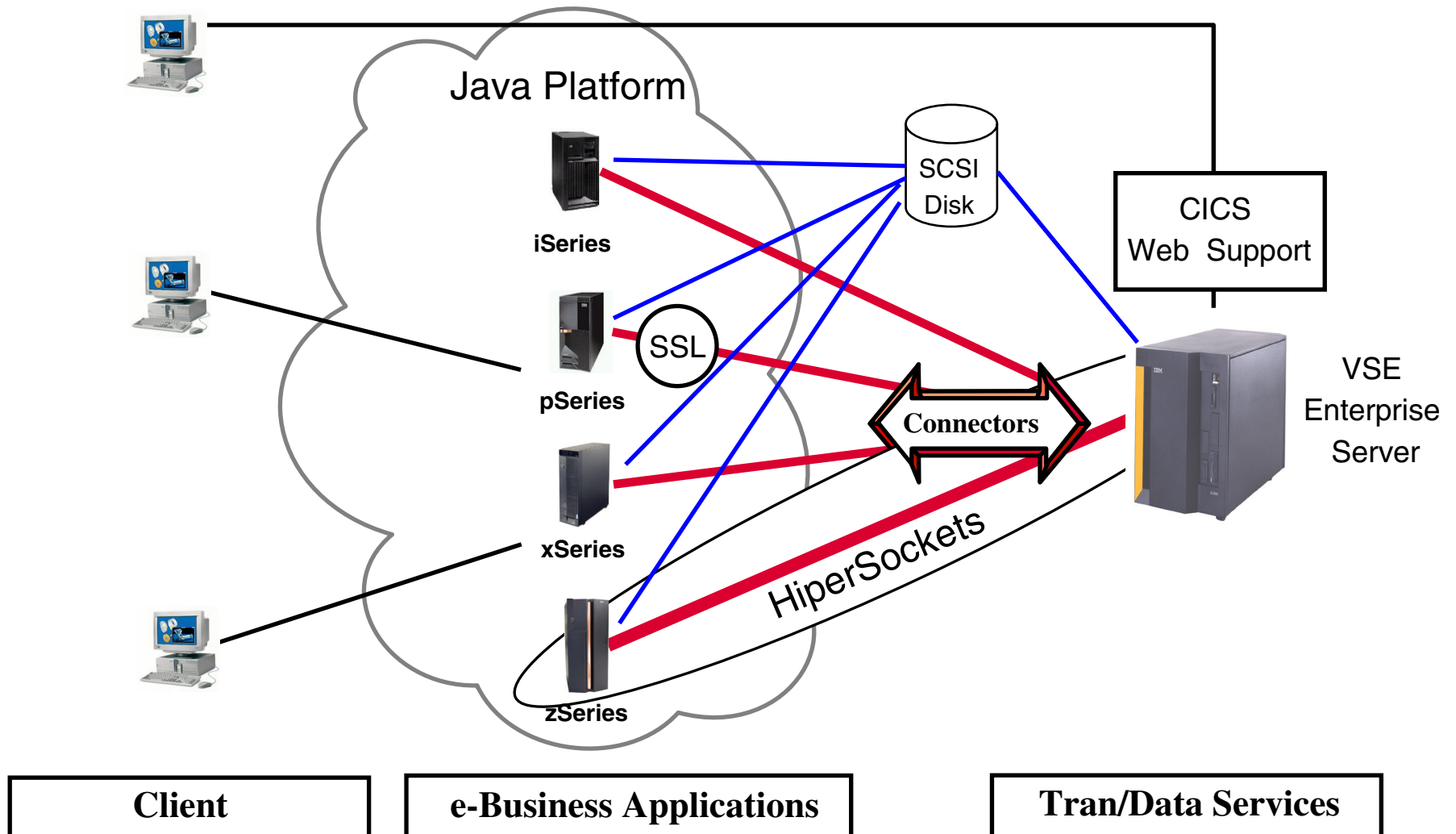

# Documentation

- Connectors for z/VSE  
<http://www.ibm.com/servers/eserver/zseries/os/vse/support/vseconn/>
- e-business Connectors User's Guide, SC33-6719
- Redbook: Getting Started with TCP/IP for VSE/ESA 1.4, SG24-5626
- Redbook: e-business Solutions for VSE/ESA, SG24-5662
- Redbook: e-business Connectivity for VSE/ESA, SG24-5950
- VSE Applications - How e-business Fits, GF22-5137
- Hints and Tips for VSE/ESA, SC33-6757
- z/VSE home page  
<http://www-1.ibm.com/servers/eserver/zseries/zvse/>