

VSE Connectors Workshop

E01 - Basic Setup of VSE e-business Connectors on Windows

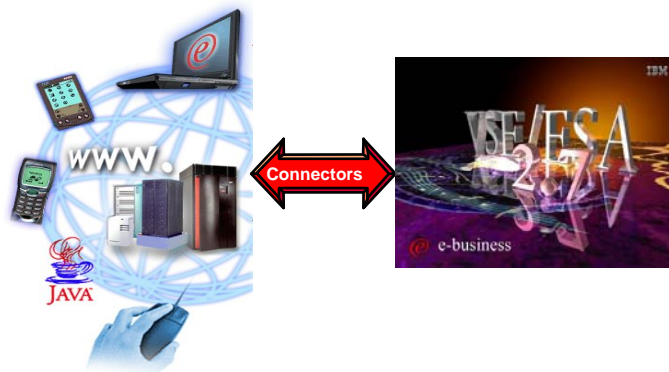

Wilhelm Mild
Ingo Franzki
VSEESA@de.ibm.com

© Copyright IBM Corporation 2004

Trademarks

References in this publication to IBM products or services do not imply that IBM intends to make them available in every country in which IBM operates. Consult your local IBM business contact for information on the products, features, and services available in your area.

AIX*, APPN*, CICS*, CICS/VSE*, CICS, DB2*, DB2 Connect, DB2 Universal Database, DFSORT, DRDA*, e-business logo*, Enterprise Storage Server, FlashCopy, HiperSockets, IBM*, IBM logo*, IBM eServer, iSeries, Language Environment*, MQSeries*, Multiprise*, pSeries, S/390*, S/390 Parallel Enterprise Server, TotalStorage, VSE/ESA, VTAM*, WebSphere*, xSeries, z/OS, z/VM, zSeries and Distributed Relational Database Architecture are trademarks or registered trademarks of International Business Machines Corporation in the United States, other countries, or both.

Linux is a registered trademark of Linus Torvalds.

Java and all Java-related trademarks and logos are trademarks or registered trademark of Sun Microsystems, Inc.

UNIX is a registered trademark in the United States and other countries, licensed exclusively through The Open Group.

Microsoft, Windows, Windows NT, Visual Basic and the Windows flat logo are Trademarks of Microsoft Corporation.

Other trademarks and registered trademarks are the properties of their respective companies.

IBM hardware products are manufactured from new parts, or new and used parts. Regardless, our warranty terms apply. This equipment is subject to all applicable FCC rules and will comply with them upon delivery.

Information concerning non-IBM products was obtained from the suppliers of those products. Questions concerning those products should be directed to those suppliers.

All statements regarding IBM's future direction and intent are subject to change or withdrawal without notice, and represent goals and objectives only.

(C) Copyright IBM Corporation 2004
All Rights Reserved.

VSE/ESA e-business Connectors

Real time access to various VSE resources is implemented using Connector technologies to embed the VSE/ESA services. These implementations are needed by today's heterogeneous IT environments. The Connector technology implements a software component on the remote system and an access component on the VSE/ESA host.

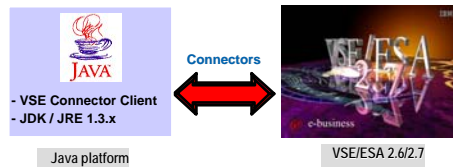

The VSE e-business Connectors included in VSE/ESA are platform independent because the remote software component is written in Java. These e-business Connectors are fully compatible with WebSphere technologies, and provide real time access to:

- VSAM
- Power queues
- Librarian
- Console
- ICCF
- DL/I (VSE 2.7)

In Addition to the functions of these Connectors, the VSE/ESA 2.6 applications can:

- Transparently access remote data
- Synchronize different data stores
- Use the Virtual Tape support delivered with VSE/ESA 2.6/2.7

By using Java technologies these Connectors enable the integration of VSE data into distributed processes and Web transactions in a heterogeneous environment and exploit the advanced functions of the IBM WebSphere Application Server.

3

Overview of possibilities with Java-Based Connector

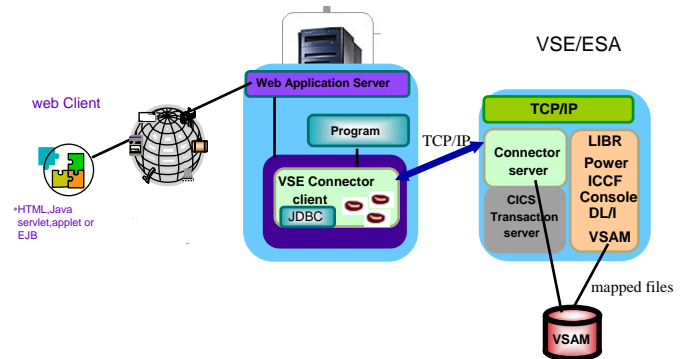

- ▶ Access to VSE/ESA Resources with Java technologies.
- ▶ VSE Connector client is part of VSE/ESA 2.5 and newer
- ▶ VSAM file access via batch or CICS (for mapped files)
- ▶ Integration of VSAM data with Web Application Server using VSAM JDBC driver

4

Workshop objective

Setup of Java-Based Connector to access VSAM data

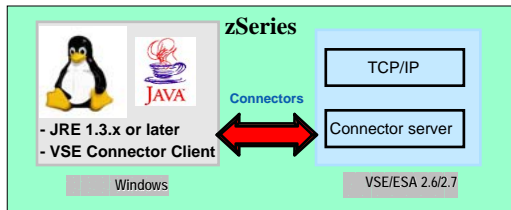

To be able to work with VSE e-business Connectors to access VSAM files we have to setup:

❖ On VSE/ESA

1. VSE Connector server

The VSE Connector server is the software component handling incoming requests from remote VSE e-business Connector programs.

❖ On the Java platform

(i.e. Windows or Linux on zSeries)

1. VSE Connector Client

The VSE Connector Client contains a Java class library with java beans which contain functions for the connection and session management and data access functions for the various resources on VSE/ESA.

2. Map the VSAM files

To access VSAM data via the VSE e-business Connectors, the structure of a VSAM record must be defined – that's the mapping step.

5

Chapter 1. Software prerequisites for Windows



STEP1.1: Verification if Java environment installed

To install the VSE Connector Client, a Java Virtual Machine (JVM) must be installed in Windows.

The JVM can be installed in different flavors.

*To just run Java programs, the JRE 1.3.x or later is needed (Java Runtime Environment),

*to develop/compile Java programs, JDK 1.3.x or higher is needed (Java Developer Kit, which includes the JRE).

To verify if a Java Virtual Machine is installed, open a Command prompt and enter command:

```
java -version
```

You should see something like:

```
Java version "1.3.1"  
Java(TM) 2 Runtime Environment, Standard Edition
```

If the messages above are shown go to [Chapter 2](#).

STEP1.2 Install a Java Environment

If following message (or similar) is shown:

```
'java' is not recognized as an internal or external command,  
operable program or batch file.
```

then your system has no Java virtual machine (Runtime Environment) installed or it can not be found in the path.

To install a Java Virtual machine download the code from IBM:

<http://www.ibm.com/developerworks/java/>

or download a SUN Version from <http://www.sun.com>

Install the downloaded JDK 1.3.x. or later.

6

Chapter 2. Setup Connector Server on VSE

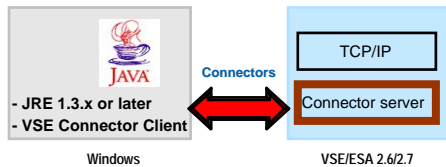

The Connector Server is the listener in VSE for incoming requests from a VSE Connector client.

- ✓ **The VSE Connector server doesn't need special setup**
- ✓ **The VSE Connector Server was setup and started in your VSE Lab installation.**

VSE is ready for incoming requests from VSE Connector Client .

Note: Steps how to setup and start the VSE Connector server are described in [Appendix A](#) .

7

Chapter 3. Setup VSE Connector Client

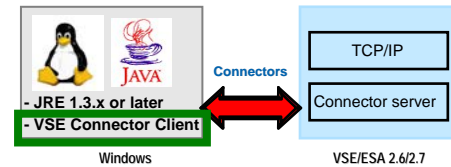

Download of VSE Connector Client code

The download of VSE Connector Client for this workshop was already done from the VSE homepage.

The Steps are described in [Appendix B](#)

STEP3.1 Install VSE Connector client

Use a Windows command prompt and change to the Connector Client directory to invoke the installation batch file.

Enter: C:
`cd C:\conntmp\connector`
`install.bat` (with command `java install` you get the same result)

The installer will guide you through the installation process of the VSE Connector client. The default directory where the VSE Connector Client will be installed is `C:\vsecon`

The VSE connector client consists of:

- a Java class library (Java Beans) – with the Connector functions
- a detailed HTML documentation about the functions and possibilities
- concepts for development, deployment and implementation
- a lot of commented and ready to run samples

8

STEP3.2 Verify settings of CLASSPATH and VSECON

To have access to the functions of VSE Connector client you need to update the CLASSPATH and the environment variable VSECON.

 **Verify the VSECON variable :**

- ▶ In a Windows command prompt enter: :
`set VSECON`

It must show the installation path of VSE Connector Client: `C:\vsecon`

To update the Classpath for the Windows system, update it in

**START – Settings - Control panel – System
- Advanced Tab - Environment Variables**

Close the dialogs with **OK** (not with Cancel) to activate the settings.
Open a **new** command prompt to verify the settings.

 **Verify the CLASSPATH:**

- ▶ In a Windows command prompt enter:
`set CLASSPATH`

The classpath must contain following files:

```
.;%VSECON%\VSEConnector.jar;%VSECON%\ibmjsse.jar;  
%VSECON%\cci.jar
```

To update the Classpath for the Windows system, update it in

**START – Settings - Control panel – System
- Advanced Tab - Environment Variables**

Close the dialogs with **OK** (not with Cancel) to activate the settings.
Open a **new** command prompt to verify the settings.

9

Chapter 4. Verify installation of Connector Client

STEP4.1: Verify VSE Connector Client documentation

To verify that the VSE Connector Client is installed properly,
open the VSE Connector Client HTML Documentation (VSEConnectors.html) in the
<vsecon> root directory

START -> Programs -> VSE Connectors -> VSEConnectors.html

The Main HTML page will be opened.

You will see the main page of the online documentation of VSE e-business
Connectors which is part of the VSE Connector Client

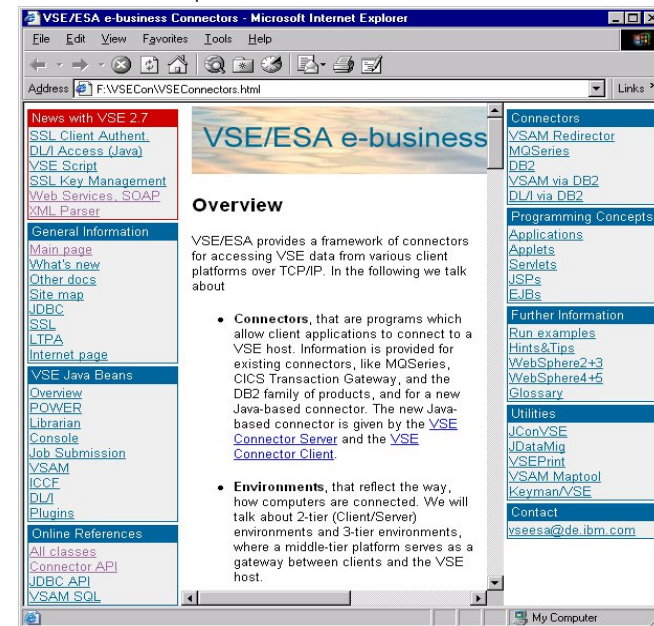

STEP4.2: Verify that VSE Connector Client can work with VSE/ESA resources

Make sure the VSE Connector server is started on VSE. To see how to start VSE Connector server see *Setup Connector Server on VSE* at the beginning of this workshop.

From the main local HTML page of VSE Connectors, (see [STEP4.1](#))

Click:

[Applications](#) in section [Programming Concepts](#) in right frame.

Click on [Examples](#) -> [How to work with Librarian Objects](#)

The commented source code explains the steps of this program.

The link [LibrApiExample.java](#) shows the entire source code of the program. The program accesses VSE Libraries via the VSE Java-Based Connector and retrieves all the Library names from VSE, the sub libraries for PRD2 and the members for Library PRD2.CONFIG.

All samples are stored on your PC in the VSE Connector Client directory:

C:\vseconlsamples

Make sure you know the IP address of the VSE system, the userid and password to use.

On a Windows command prompt navigate to the **C:\vseconlsamples** directory

Start the program by typing:

LibrApiExample.bat

The system will give you the results like shown:

```

C:\WINNT\System32\cmd.exe
LibrListener: listAdded(), member = SRU$SYS_PROC
LibrListener: listAdded(), member = MILD_PROFDTI
LibrListener: listAdded(), member = SVSA_PROFDTI
LibrListener: listAdded(), member = ATCSTR00.SAUE
LibrListener: listAdded(), member = IJBDAT.SAUE
LibrListener: listAdded(), member = UTMMDL.SAUE
LibrListener: listAdded(), member = UTMNSNA.SAUE
LibrListener: listAdded(), member = IESLIBDF.Z
LibrListener: listAdded(), member = IESPLGIN.Z
LibrListener: listAdded(), member = IESUSERS.Z
LibrListener: listAdded(), member = IESUGSRU.Z
LibrListener: listAdded(), member = JMSTART.Z
LibrListener: listAdded(), member = JMSTOP.Z
LibrListener: listAdded(), member = JMSTPNRT.Z
LibrListener: listEnded()
Number of members in CONFIG : 47
First member in CONFIG : DTSECTXS.A
Number of records: 394
Logical record length: 80
Creation date: Mon Oct 29 15:28:42 CEI 2001
Last update: Mon Feb 17 14:56:37 CEI 2003
Member format is text
DTSECTXS.A downloaded.
  
```

11

Accessing VSAM data from remote systems

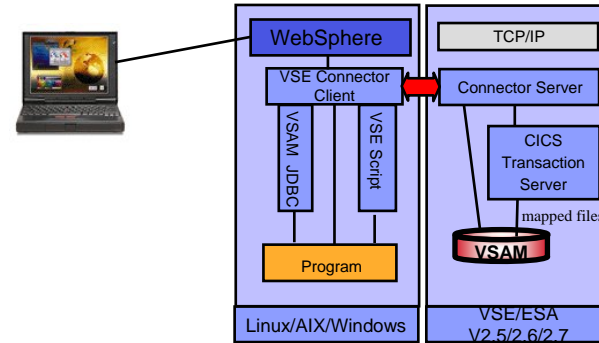

Using the same technology, Java-Based Connector, the access to VSAM files in VSE can be realized using the VSE Connector client component and interface with it in different ways:

- ▶ With the Java beans provided by VSE Connector client directly
- ▶ Via a VSAM JDBC driver
- ▶ Via a script interface
- ▶ The access can then be done via batch or via CICS

Various samples and descriptions are in VSE Connector client online documentation – [STEP 4.1](#)

- ▶ In all cases, because VSAM access is record based, a **mapping** must be done prior to can access VSAM data from remote

12

Mapping of a VSAM cluster

VSE/VSAM Record structure (i.e. from EMPPROG.COBOL Copy book).

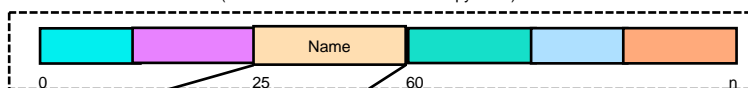

Column:
 →title: Name
 →Offset:25
 →length:35
 →type: STRING
 →Descr: Person name

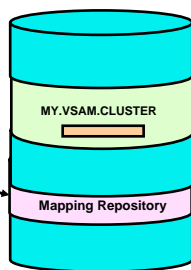

Mapping characteristics:

- ▶ No changes to VSAM data
- ▶ Mapping information stored in a repository in VSAM (VSE.VSAM.MAPPING.DEFS)
- ▶ Possible data types: STRING, binary, signed number, unsigned number, packed data
- ▶ Multiple maps and views (subset of map fields) supported
- ▶ Mapping of VSAM cluster can be done using:
 - ▶ IDCAMS RECMAP command on VSE/ESA,
 - ▶ VSE Navigator or a self written Java program
 - ▶ **Maptool – standalone Java program,**
- ▶ We will use the Maptool in this workshop

13

Chapter 5. Mapping a VSAM file for access through batch or CICS

To have access via Connectors to a VSAM file, the structure of the VSAM record must be defined. This allows the Connector to translate the different types of fields within a VSAM record from the VSE EBCDIC format into the ASCII format on the remote platform.

The definition of a set of fields for a VSAM record is called the **map** (similar to a relational table definition). The elements of a map are **columns**. A subset of the columns can be grouped in a **view**, were a view refers to columns of a map rather than having definitions of the columns. Multiple maps and views can be defined for a VSAM cluster.

STEP5.1 Mapping specification for a VSAM cluster

The VSAM cluster used is **FLIGHT.ORDERING.FLIGHTS.TEAMxx**

The Map **FLIGHTS_MAP** we have to define is based on the VSAM cluster with following record structure. This structure is the base for our column definitions.

These definitions are typically done in **COBOL copy books**.

We will use the **Flights Cobol Copy** book and the Java tool, called **Maptool** to define the map in VSE.

Offset	Length	Type	Key	Field Name	Description
0	4	UNSIGNED	yes	FLIGHT_NUMBER	Flight Number
4	20	STRING	no	START	Start
24	20	STRING	no	DESTINATION	Destination
44	5	STRING	no	DEPARTURE	Departure (hh:mm)
49	5	STRING	no	ARRIVAL	Arrival (hh:mm)
54	4	UNSIGNED	no	SEATS	Seats
58	4	STRING	no	RESERVED	Seats reserved
62	4	PACKED	no	PRICE	Price
66	20	STRING	no	AIRLINE	Airline

Make sure you know the IP address of the VSE system, userid and password.

14

Create a Map using Maptool and a COBOL Copybook

STEP5.2 Mapping of FLIGHT.ORDERING.FLIGHTS.TEAMxx using Maptool

The Map for a VSAM file can be defined using different ways as you know from the first part of this workshop.

We use here, the Standalone Java tool called Maptool which was downloaded from the FTP server.

To start the Maptool, use a Windows command prompt window and enter:

C:
cd C:\maptool
run.bat

You will see a window like this:

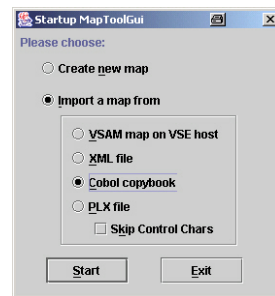

Import the Cobol Copy Book *Flights.cb* with the definitions of the VSAM record.

Click:

Import a map from
COBOL Copybook

Click on **Start**.

Navigate to directory **C:\maptool**

Click on the Cobol Copybook file *Flights.cb*

Click: **Open**

15

You will see a window like the one below:

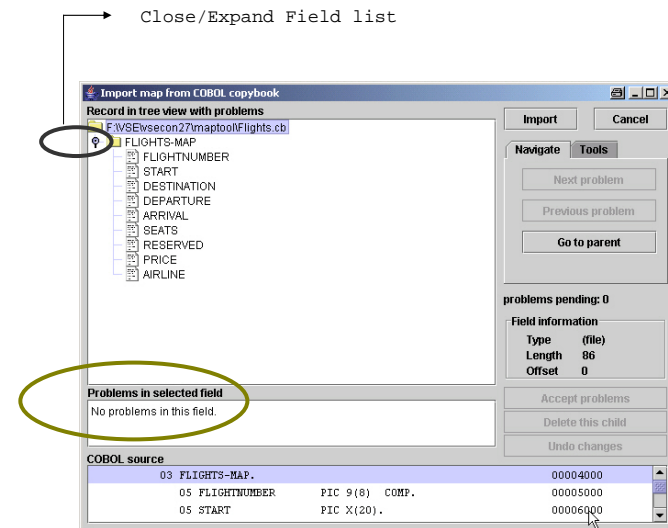

It shows the imported Cobol Copy book transformed in a structure. On the lower end you see the original Cobol Copy book lines.

Verify that there are **no conflicts**.

Click on **Import**.

16

The generated mapping definitions will be shown. As description the lines from the Cobol Copy book are generated. Now changes could be done if needed (different Column names than the Field names in Cobol Copy book, change the map or parts of a VSAM record by deleting some columns, or have another description for the columns). Verify and compare the definitions of the fields with the definitions in Step 5.1.

Fieldname	Length	Offset	Type	Description
FLIGHTNUM...	4	0	UNSION..	05 FLIGHTNUMBER PIC 9(9) COMP. 0000...
START	20	4	STRING	05 START PIC X(20). 00006000
DESTINATION	20	24	STRING	05 DESTINATION PIC X(20). 00007000
DEPARTURE	5	44	STRING	05 DEPARTURE PIC X(5). 00008000
ARRIVAL	5	49	STRING	05 ARRIVAL PIC X(5). 00009490
SEATS	4	54	UNSION..	05 SEATS PIC 9(9) COMP. 00010000
RESERVED	4	58	STRING	05 RESERVED PIC 9999. 00011000
PRICE	4	62	PACKED	05 PRICE PIC 9(9) COMP-3. 00012000
AIRLINE	20	66	STRING	05 AIRLINE PIC X(20). 00013000

This definitions can now be exported in different formats, in XML or as Java structure or as definitions for the VSE system – that’s what we need. To export the definitions to VSE and create there a map do:

Click: **Export**
VSE VSAM Map
Export

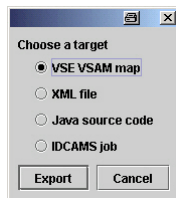

The window below is shown asking you for the authorization ID, and parameters for VSE.

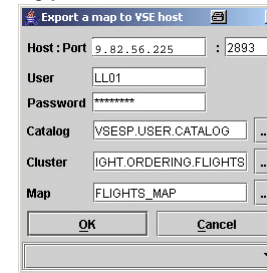

At this point the map can be generated for access trough **batch (STEP 5.3)** or for access trough CICS (**STEP 5.4**).

The difference is only the map name:

Map for batch access:

VSESP.USER.CATALOG/FLIGHT.ORDERING.FLIGHTS.TEAMxx/FLIGHTS_MAP

Map for CICS access:

#VSAM.#CICS.DBDCIC/FLIGHxx/FLIGHTS

Define these maps in the next Steps.

STEP5.3 Generate the map for batch access

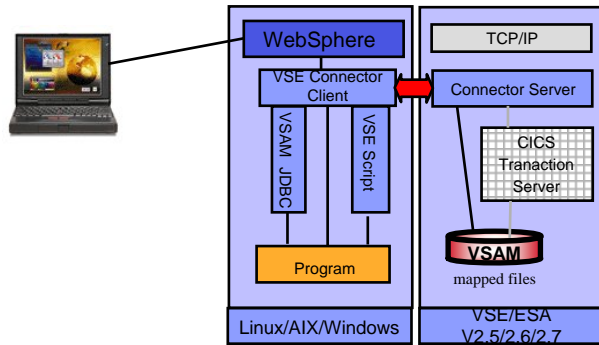

Specify the parameter, (**xx** – is your team number)
VSE IP: **9.82.56.225** Port: **2893**

VSE user: **LLxx**
Password: **linlabxx**

Catalog : click on the right and select, or type
VSESP.USER.CATALOG

Cluster: click and select or type
FLIGHT.ORDERING.FLIGHTS.TEAMxx

Map: **FLIGHTS_MAP**
Click: **OK**

Now the map is defined in the specified VSE system and enables access to the VSAM file in batch mode.

STEP5.4 Generate a map for CICS access

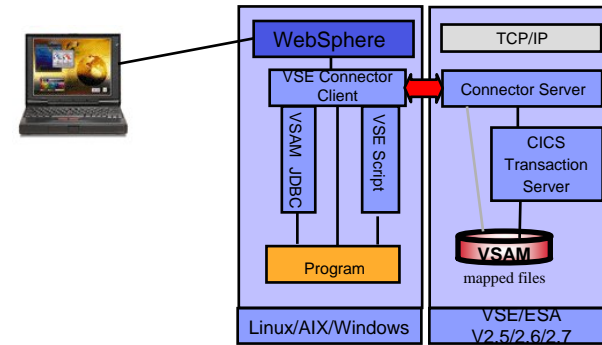

After you defined the map for batch access you could now use the same definitions to define a map for CICS access. But for CICS we want to use a map with fewer columns defined.

The Map **FLIGHTS** should contain the following field definitions:

Offset	Length	Type	Key	Field Name	Description
0	4	UNSIGNED	yes	FLIGHT_NUMBER	Flight Number
66	20	STRING	no	AIRLINE	Airline
4	20	STRING	no	START-AIRPORT	Start
24	20	STRING	no	DESTINATION	Destination
62	4	PACKED	no	PRICE	Price

Generate a map for CICS access (continued)

Your Window in Maptool should look like this:

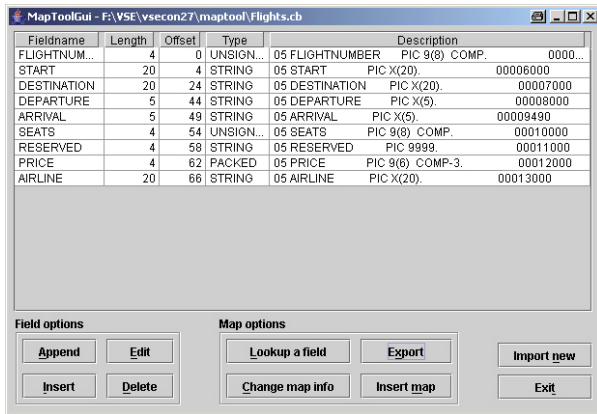

You need to delete the Columns: Departure, Arrival, Seats, Reserved

To **delete a Field** definition click on it and then click **DELETE**

To **change a field content**, click on the field and do the change.

Generate a map for CICS access (continued)

After finishing the changes, click:

Export
VSE VSAM MAP
Export

The window below is shown asking you for the authorization and parameters for VSE.

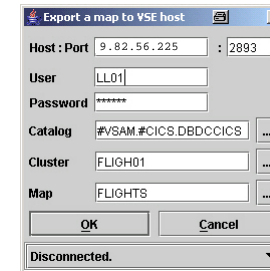

Specify the parameter, (**xx** – is your team number)
VSE IP: **9.82.56.225** Port: **2893**

VSE user: **LLxx**
Password: **linlabxx**

Catalog : click **...** on the right and select, or type
#VSAM.#CICS.DBDCCICS

Cluster: click **...** and select or type **FLIGHxx**

Map: **FLIGHTS**
Click: **OK**

Now the map is defined in the specified VSE system and enables access to the VSAM file via the CICS with the ID DBDCCICS.

Chapter 6. Connector Sample to access VSAM data in batch

STEP6.2: Access VSAM data via Java-Based Connector using the Java sample program VsamDisplayExample

All samples are stored in the VSE Connector Client directory:
C:\vsecon\samples

The Java source code is in: C:\vsecon\samples\com\ibm\vse\samples

We will work with VsamDisplayExample.java

The program displays the content of a mapped VSAM file.

Start the program. In a Windows command prompt enter:

```
C:
cd C:\vsecon\samples
VsamDisplayExample.bat
```

You got an error. That's because of a wrong name of the VSAM file.
In next step you'll correct it .

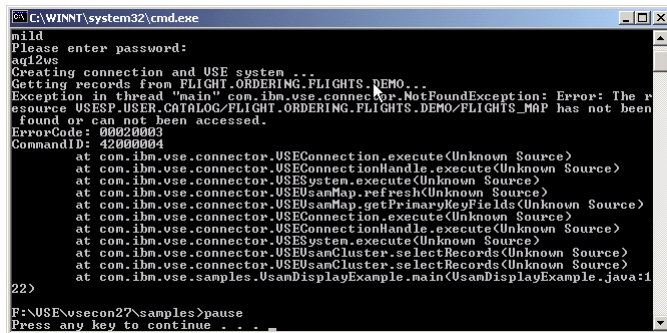

```
C:\WINNT\system32\cmd.exe
mild
Please enter password:
aq12us
Creating connection and USE system ...
Getting records from FLIGHT_ORDERING.FLIGHTS.REMO...
Exception in thread "main" com.ibm.vse.connector.NotFoundException: Error: The resource USESP.USER.CATALOG/FLIGHT_ORDERING.FLIGHTS.DEMO/FLIGHTS_MAP has not been found or can not be accessed.
ErrorCode: 00020003
CommandID: 42060004
at com.ibm.vse.connector.USEConnection.execute(Unknown Source)
at com.ibm.vse.connector.USEConnectionHandle.execute(Unknown Source)
at com.ibm.vse.connector.USESystem.execute(Unknown Source)
at com.ibm.vse.connector.USESamMap.refresh(Unknown Source)
at com.ibm.vse.connector.USESamMap.getPrimaryKeyFields(Unknown Source)
at com.ibm.vse.connector.USEConnection.execute(Unknown Source)
at com.ibm.vse.connector.USEConnectionHandle.execute(Unknown Source)
at com.ibm.vse.connector.USESystem.execute(Unknown Source)
at com.ibm.vse.connector.USESamCluster.selectRecords(Unknown Source)
at com.ibm.vse.connector.USESamCluster.selectRecords(Unknown Source)
at com.ibm.vse.samples.VsamDisplayExample.main(VsamDisplayExample.java:122)
F:\USE\vsecon27\samples>pause
Press any key to continue . . .
```

23

STEP6.2: Modify Java program VsamDisplayExample

Exercise: The name of the VSAM file and the map must be modified.

The source program is in C:\vsecon\samples\com\ibm\vse\samples

- Edit program VsamDisplayExample.java (i.e. Notepad)
 - In a Windows command prompt enter:

C:

```
cd C:\vsecon\samples\com\ibm\vse\samples
Notepad VsamDisplayExample.java
```

- Do the following changes:

- the file name *fileName* to: **FLIGHT_ORDERING.FLIGHTS.TEAMxx**

where xx is your team number

- the map name *mapName* to: **FLIGHTS_MAP**

- Save the modified source.

- Compile the changed program

To compile the source in the command prompt enter:

```
cd C:\vsecon\samples
javac com\ibm\vse\samples\VsamDisplayExample.java
```

Note: the compile must be done from the C:\vsecon\samples directory because all samples belong to the Java package com.ibm.vse.samples

If the compile returns no errors, execute the program, enter:

```
C:\vsecon\samples\VsamDisplayExample.bat
```

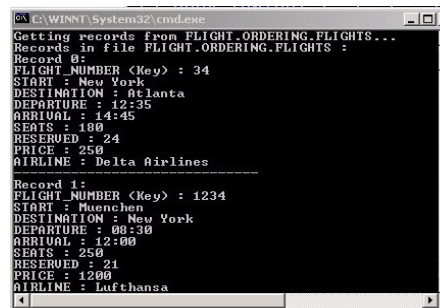

```
C:\WINNT\system32\cmd.exe
Getting records from FLIGHT_ORDERING.FLIGHTS...
Records in file FLIGHT_ORDERING.FLIGHTS :
Record 0:
FLIGHT_NUMBER <Key> : 34
START : New York
DESTINATION : Atlanta
DEPARTURE : 12:35
ARRIVAL : 14:45
SEATS : 400
RESERVED : 24
PRICE : 250
AIRLINE : Delta airlines
-----
Record 1:
FLIGHT_NUMBER <Key> : 1234
START : Muenchen
DESTINATION : New York
DEPARTURE : 08:30
ARRIVAL : 12:00
SEATS : 250
RESERVED : 21
PRICE : 1200
AIRLINE : Lufthansa
-----
4
```

Note: [Appendix D](#) describes the access to the same file via CICS

24

Summary

Major Steps to install VSE Connector Client on a workstation

- ✓ install Java Runtime Environment (JRE) or Java Developer Kit (JDK)
 - ✓ free download from SUN or IBM
 - ✓ version 1.3.x or later
 - <http://www.ibm.com/developerworks/java/>
- ✓ download VSE Connector client
<http://www-1.ibm.com/servers/eserver/zseries/os/vse/support/vseconn/vsecon.html>
- ✓ install VSE Connector client
 - ✓ at a command prompt enter: `java install`
- ✓ download VSE Navigator
<http://www-1.ibm.com/servers/eserver/zseries/os/vse/support/vseconn/vsenavi.html>
- ✓ install VSE Navigator (see **Appendix F**)
 - ✓ at a command prompt enter: `java install`

25

Appendix A. Setup Connector Server on VSE



The Connector Server is the listener in VSE for incoming requests from a VSE Connector client.

STEP A.1: Setup correct TCP/IP system ID for VSE Connector server

- ✓ TCP/IP for VSE/ESA has a **system ID** (default is **00**), specified in TCP/IP startup Job (the default name is TCP/IP00):

```
// EXEC IPNET,SIZE=IPNET,PARM='ID=00',INIT=.....
```

- ✓ To use the TCP/IP services from another partition (i.e. VSE Connector Server) this partition has to 'know' the system ID of TCP/IP. This is specified in the VSE Connector server startup job as follows:

```
// OPTION SYSPARM='nn' - where nn is the system ID.
```

- ★ **Recommendation:** Copy the skeleton SKVCSSTJ from ICCF lib 59 in your primary library, adjust and submit it.

- ★ It's the startup job of VSE Connector server.

STEP A.2: Start VSE Connector server

At the VSE console enter:

```
r rdr,STARTVCS
```

several messages will appear on the console. The server is ready for e-business when the following messages are shown:

```
IESC1002I FINISHED STARTUP OF VSE CONNECTOR SERVER  
IESC1003I WAITING FOR CONNECTIONS OF CLIENTS...
```

Now, VSE is ready for incoming requests from VSE Connector Client .

26

Appendix B: Download from the Internet



Open the VSE Homepage with a web browser:

<http://www-1.ibm.com/servers/eserver/zseries/os/vse/>

Click on "Service and Support" on the left side and then on "e-business connectors and utilities".

The page opened contains the VSE Connector Client and the tools that can be downloaded for free.

In the upper left corner you see **VSE Connector Client** which represents the remote component of the e-business Connectors.

Connector Components	
VSE Connector Client	Updated: 06/2003
Provides the VSE Java Beans class library, together with extensive online doc, Javadoc, and coding samples for all kinds of Java programs, like small applications, servlets, applets, and EJBs.	
W-book: IESINCON.W in PRD1.BASE	
Platform: VSE/ESA 2.5 or later	
 Details and Download	
 FAQ and troubleshooting tips	

Click on:

[Details and Download](#)

The page explains the most important functions of the VSE Connector Client, the counterpart on Windows of VSE Connector Server on VSE/ESA. It also mentions that a **Java** environment is needed.

27

Appendix C: Connectors Security

To access VSE resources from remote platforms, the VSE security applies.

The security is checked using Racroute requests.

Using a Basic Security manager or an Extended Security Manager, allows the global or more granular check of accesses to VSE resources. Connectors can work using secured (SSL) connections.

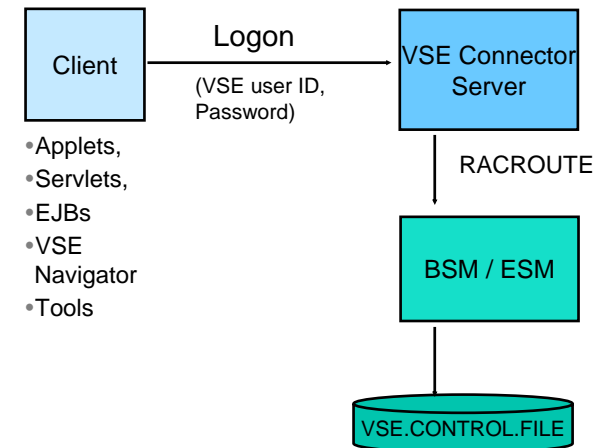

28

Appendix D. Connector Sample to access VSAM data via CICS

STEPD.1: Access FLIGHTS.ORDERING.FLIGHTS via CICS

Since most of VSAM files are active in a CICS environment, to update them via Connectors, the VSAM cluster must be defined with Share Option 4 or the access with the Connectors must be done via CICS.

We'll use the same sample `VsamDisplayExample.java` from `<vsecon>\samples\com\ibm\vse\samples`

To can have access via CICS the file must be defined in CICS .
The file `FLIGHTS.ORDERING.FLIGHTS.TEAMxx` is defined in CICS as `FLIGHxx`
How these definitions can be done is described in [Appendix E](#).

The map must be defined for this access (Step 5.4) – specific here is the catalog name for Connector access which has a name of:
`#VSAM.#CICS.<CICSAPPLID>`

In our case the CICS used is the one having APPLID DBDCCICS.

All samples are stored on your system in the directory: `<vsecon>\samples`
The Java source code is in: `<vsecon>\samples\com\ibm\vse\samples`

The Map `FLIGHTS` defined in [STEP 5.3](#) contains the following field definitions:

Offset	Length	Type	Key	Field Name	Description
0	4	UNSIGNED	yes	FLIGHT_NUMBER	Flight Number
66	20	STRING	no	AIRLINE	Airline
4	20	STRING	no	START-AIRPORT	Start
24	20	STRING	no	DESTINATION	Destination
62	4	PACKED	no	PRICE	Price

29

STEP D.2: Modify Java program `VsamDisplayExample` for access trough CICS

Exercise: The name of the VSAM file and map must be modified.

The source program is in `C:\vsecon\samples\com\ibm\vse\samples`

- Edit program `VsamDisplayExample.java` (i.e. Notepad)
- In a Windows command prompt enter:

```
C:  
cd C:\vsecon\samples\com\ibm\vse\samples  
Notepad VsamDisplayExample.java
```

- Do the following changes:
 - Catalog name, `catName` : `#VSAM.#CICS.DBDCCICS`
 - the File name, `fileName` : `FLIGHxx` where xx is your team number
 - the Map name, `mapName`: `FLIGHTS`
- Save the modified source.
- Compile the changed program

To compile the source in the command prompt enter:

```
cd C:\vsecon\samples  
javac com\ibm\vse\samples\VsamDisplayExample.java
```

Note: the compile must be done from the `C:\vsecon\samples` directory because all samples belong to the Java package `com.ibm.vse.samples`

If the compile returns no errors, execute the program, enter:

```
C:\vsecon\samples>VsamDisplayExample.bat
```



```
Getting records from FLIGHT_ORDERING.FLIGHTS ...  
Records in file FLIGHT_ORDERING.FLIGHTS :  
Record 0:  
FLIGHT_NUMBER (Key) : 34  
START : New York  
DESTINATION : Atlanta  
DEPARTURE : 12:35  
ARRIVAL : 14:45  
SEATS : 180  
RESERVED : 24  
PRICE : 250  
AIRLINE : Delta Airlines  
-----  
Record 1:  
FLIGHT_NUMBER (Key) : 1234  
START : Muenchen  
DESTINATION : New York  
DEPARTURE : 00:30  
ARRIVAL : 12:00  
SEATS : 250  
RESERVED : 21  
PRICE : 1200  
AIRLINE : Lufthansa
```

30

Appendix E: Define a file in CICS

Logon to your VSE system using the icon on your desktop:

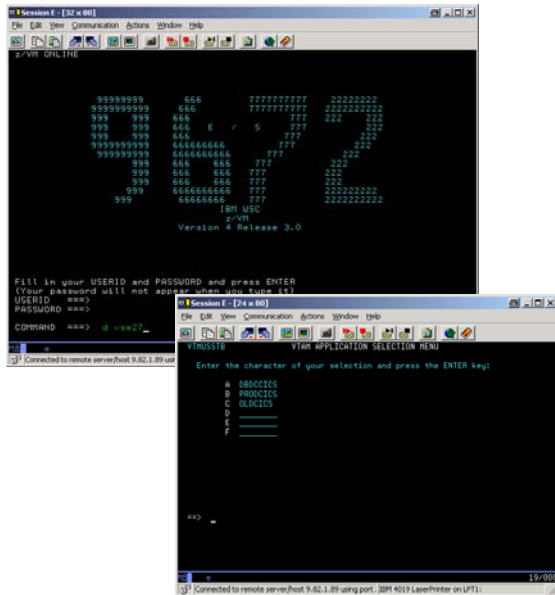

On Command line Enter:
d vse27
A

31

On the CICS logon screen enter:
User: **LLxx** (xx- is your team number 00 – 10)
Password: **linlabxx**
You are now in the **Interactive User Interface (IUI)** of VSE.

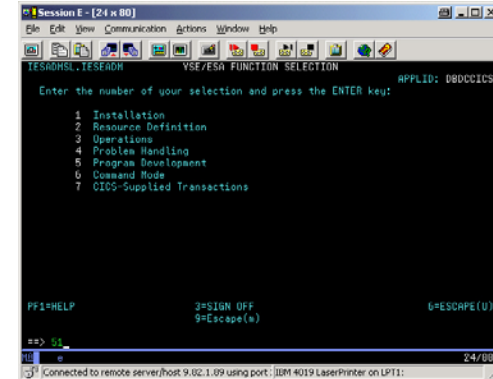

Press: **PF6** (to go into the CICS command mode)
Hit **CEDA def File (FLIGHxx)**

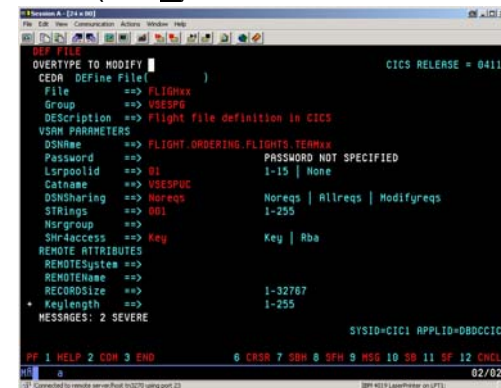

Enter the required parameters.

32

Hit **PF8** to go to the next screens and type **YES** to all Operations:

```

CICS RELEASE = 0411
CEDA DEFINE FILE( FLIGHXX )
+ INITIAL STATUS
STATUS ==> Enabled      Enabled | Disabled | Unenabled
Openise ==> Firstref    Firstref | Startup
BUFFERS
DATABuffers ==> 00002    2-32767
Indexbuffers ==> 00001  1-32767
DRITABLE PARAMETERS
Table ==> No            No | Cics | User
Maxouprec ==>          16-1677215
DATA FORMAT
RECORDFormat ==> V      V | F
OPERATIONS
Add ==> yes            No | Yes
Browse ==> yes         No | Yes
DElete ==> yes         No | Yes
REAd ==> yes           Yes | No
+ Update ==> yes       No | Yes
SYSID=CICL APPLID=08DCCIC8
PF 1 HELP 2 CON 3 END          6 CSR 7 SBH 8 SFH 9 MSG 10 SB 11 SF 12 CNCL
  
```

Press: **ENTER** to complete the definition

To activate the definition **install FLIGHxx** in the group you specified in the definition:

```

OVERTYPE TO MODIFY
CEDA Install
All
Connection ==>
Doctemplate ==>
File ==> FLIGHxx
Lsrpool ==>
Mapset ==>
PARTitionset ==>
PARTner ==>
PROFile ==>
PROGram ==>
TcpiService ==>
TERminal ==>
TRANClass ==>
TRANSACTION ==>
TYpeters ==>
Group ==> VSESP1
S No GROUP value has been previously specified so there is no current value
to assume.
SYSID=CICL APPLID=08DCCIC8
PF 1 HELP 2 CON 3 END          6 CSR 7 SBH 8 SFH 9 MSG 10 SB 11 SF 12 CNCL
  
```

Appendix F. Graphical interface to VSE/ESA, VSE Navigator

VSE Navigator is an application based on the VSE Connector Client. A wide range of functions of the VSE e-business Connectors, are incorporated in the VSE Navigator. With this graphical interface, VSE system resources and data can be accessed, displayed, changed and monitored.

In STEP3.3 and 3.4 you downloaded it and unzipped it from FTP server. To run the Navigator, the Connector client must be installed on your workstation. Go to next steps to install and run it.

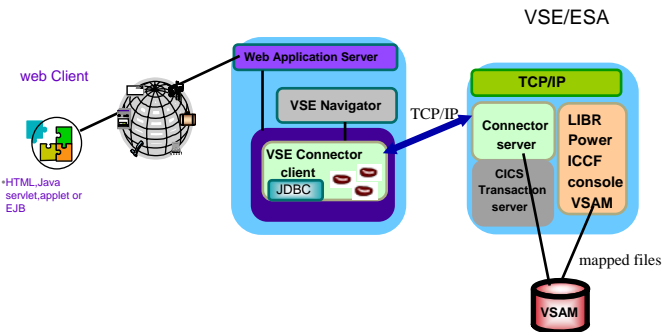

Note: You can also download the VSE Navigator from the [VSE Home page](#).
(link [Service and Support](#) -> [VSE Connectors](#))

STEP F.1: Install VSE Navigator

To install VSE Navigator, use a Windows command prompt

```
Enter: C:
       cd C:\conntmp\navi
       install.bat
```

NOTE: Install Navigator in the same directory with VSE Connector client:
C:\vsecon

Navigator can be used to work with multiple VSE systems at the same time from a graphical interface.

STEP F.2: First configuration of VSE Navigator

✓ At the first **start of VSE Navigator** you'll be asked for settings.

To start it, in a command prompt enter:

```
C:
cd C:\vsecon
run.bat
```

You can set your look and feel, local directories and are asked for local applications.

- ✓ Local applications
 - ✓ For Browser enter: **C:\Program Files\Internet Explorer\IEXPLORE.EXE**
 - ✓ For file compare entry, type **windiff**

These settings can be changed later on at any time.

Now the Navigator is ready and the next step is to define the VSE systems
That Navigator should have access to.

35

STEP F.3: Define host and access it

✓ After Navigator is started define a VSE system to it:

click: **Configuration**

Hosts

enter Name you'd like to give to your VSE in *Description*

enter the IP address: **9.82.56.225** ,

and userid: **LLxx** xx – is your team number

click **SAVE**

CLOSE

Right click on the Host Icon and then **Connect**

Enter the password (**linlabxx**) and then **OK**.

Make sure VSE Connector Server (STARTVCS) is running on VSE.

If you expand the Host folder you get a window like the one below.

Right click on the host Folder shows various functions available.

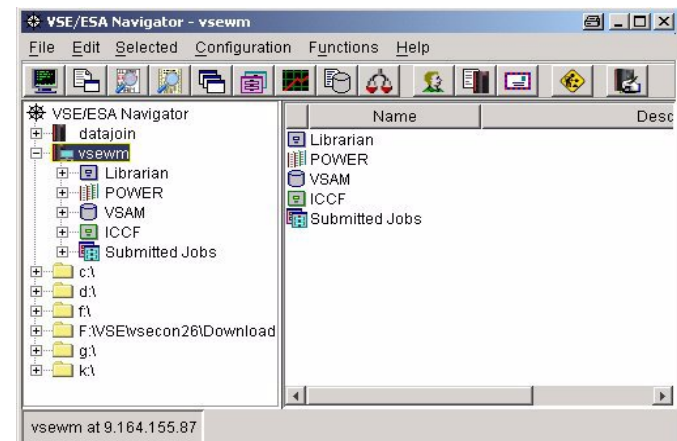

36

STEP F.4: Display a VSAM file with Navigator

To look at the same VSAM file you worked with the Java Program, after You started VSE Navigator and connected to the VSE system:
Click:

- expand VSAM Folder
- expand **VSESP.USER.CATALOG** folder
- expand the cluster **FLIGHT.ORDERING.FLIGHTS.TEAMxx**
- right click on the MAP **FLIGHTS_MAP**
- click: **Display VSAM data**

At this time, you used the same function as with the Java program, with the advantage of the graphical possibilities of VSE Navigator.

In the view below if you right click on a **ROW** and then **change**, you are able to do changes based on individual columns direct in the VSAM file.

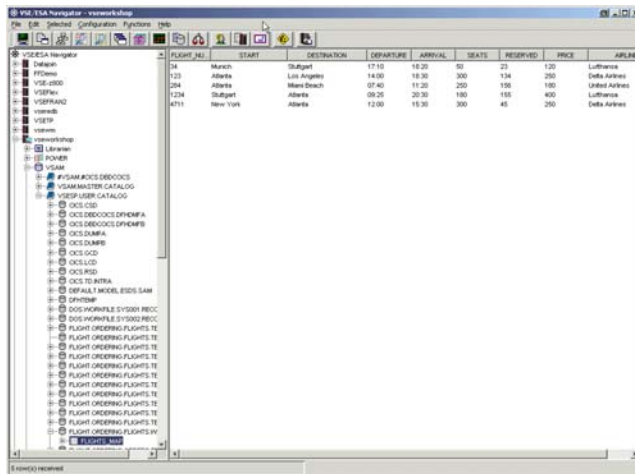

FLIGHT_NO	START	DESTINATION	DEPARTURE	ARRIVAL	SEATS	RESERVED	PRICE	AIRLINE
34	March	Stuttgart	17:10	18:20	50	23	120	Lufthansa
125	Atlanta	Los Angeles	14:00	18:30	300	134	280	Delta Airlines
284	Atlanta	Miami Beach	07:40	11:20	200	108	180	United Airlines
1234	Stuttgart	Atlanta	09:25	20:30	180	115	400	Lufthansa
4711	New York	Atlanta	12:00	15:30	300	45	250	Delta Airline

Additional Information

- **VSE/ESA Home Page**
<http://www.ibm.com/servers/eserver/zseries/os/vse/>
- **e-business Connectors User's Guide**
SC33-6719
<http://www-1.ibm.com/servers/eserver/zseries/os/vse/pdf/ieswue21.pdf>
- **e-business connectors tools**
<http://www.ibm.com/servers/eserver/zseries/os/vse/ebus/home.html>



- **e-business Connectivity for VSE/ESA** SG24-5950
- **e-business Solutions for VSE/ESA** SG24-5662
- **Servlet and JSP Programming** SG24-5755
- **Linux Web Hosting with WebSphere, DB2, and Domino** SG24-6007
- **NEW: Linux on zSeries: Connectors to z/OS and VSE** SG24-7042

VSEESA@de.ibm.com

