

E10

What's New in MQ:

Introduction and Update for MQSeries

Christianne Sims
S/390 VSE VM System Center
csims@us.ibm.com



IBM Trademarks

IBM is a Registered Trademark of
International Business Machine Corporation

Trademarks of International Business Machine Corporation

MQSeries
CICS
CICS OS/2
System/390
RISC System/6000
VSE/ESA
CICS TS
OS/2

COBOL for VM
ACF/VTAM
MVS/ESA
RACF
CICS/ESA
IMS/ESA
AS/400

C/400
COBOL/VSE
LE
OS/400
CICS/6000
AIX
VM/ESA
OS/390

Other Trademarks

VAX, VMS, Digital are Trademarks of Digital Equipment Corporation

Windows, Windows NT, Microsoft are Trademarks of MicroSoft Corporation

Tandem, Guardian, Himalaya are Trademarks of Tandem Computers Inc

HP-UX is a Trademark of Hewlett-Packard Company

SunOS and Solaris are Trademarks of Sun Microsystems Inc

Intel is a Trademark of Intel Corporation

AT&T is a Trademark of American Telephone & Telegraph Corporation

SCO is a Trademark of Santa Cruz Operations Inc

Unixware is a Trademark of Novell Inc

UNIX is a Registered Trademark licensed through X/Open Company Ltd

All other product or company names are Registered Trademarks or Trademarks of their respective holders.

AGENDA

- What is MQSeries
- MQSeries for VSE
- MQSeries Client
- MQSeries and the Internet
- Software Requirements

MQSeries Connects Applications

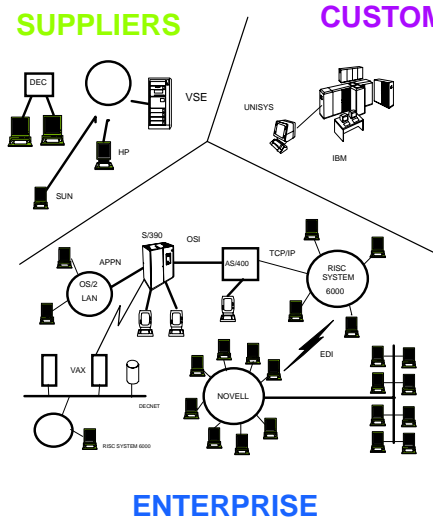

- Islands of Automation
 - Ease of use
 - Data placement
 - Improved operating costs
- Bridging Islands of Automation
 - Limited design choices
 - High implementation costs
 - High maintenance costs
 - Inflexible solutions
- Connects VSE and VM with
 - IBM(OS/390 400 OS2 AIX)
 - OEM(NT HP Linux SUN DEC...)
- Application Integration

A Simple Example

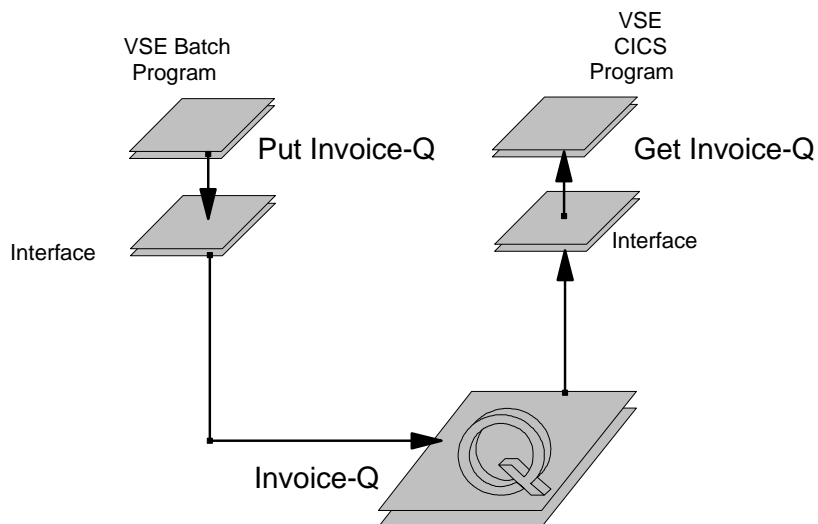

Shielding Developers

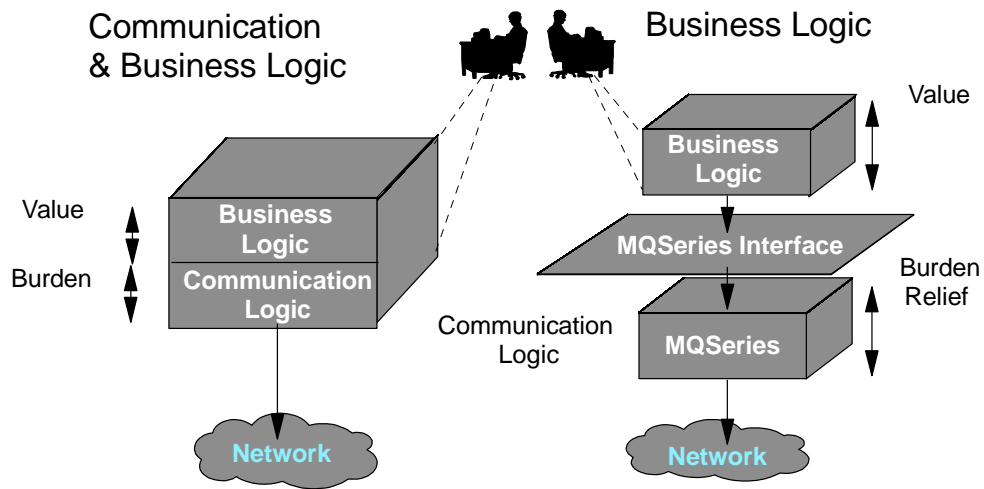

How MQSeries Works

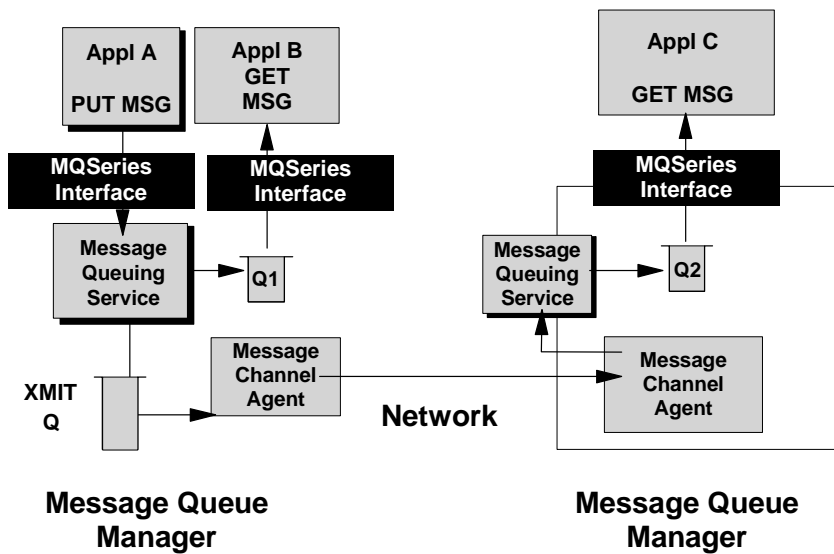

MQSeries Client

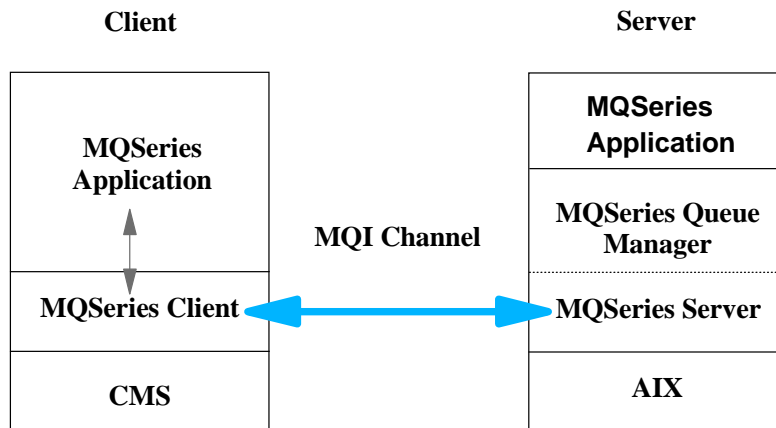

Server to Client Connection

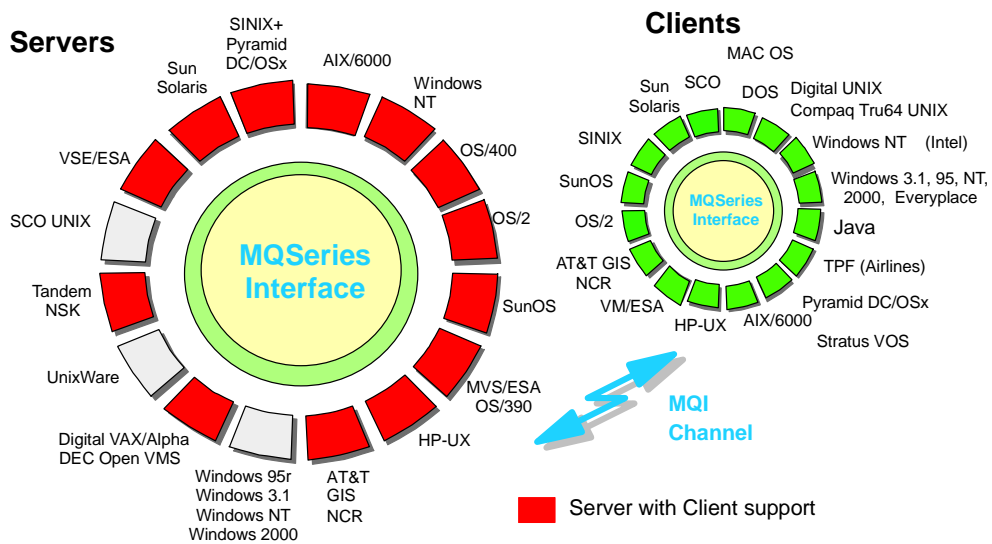

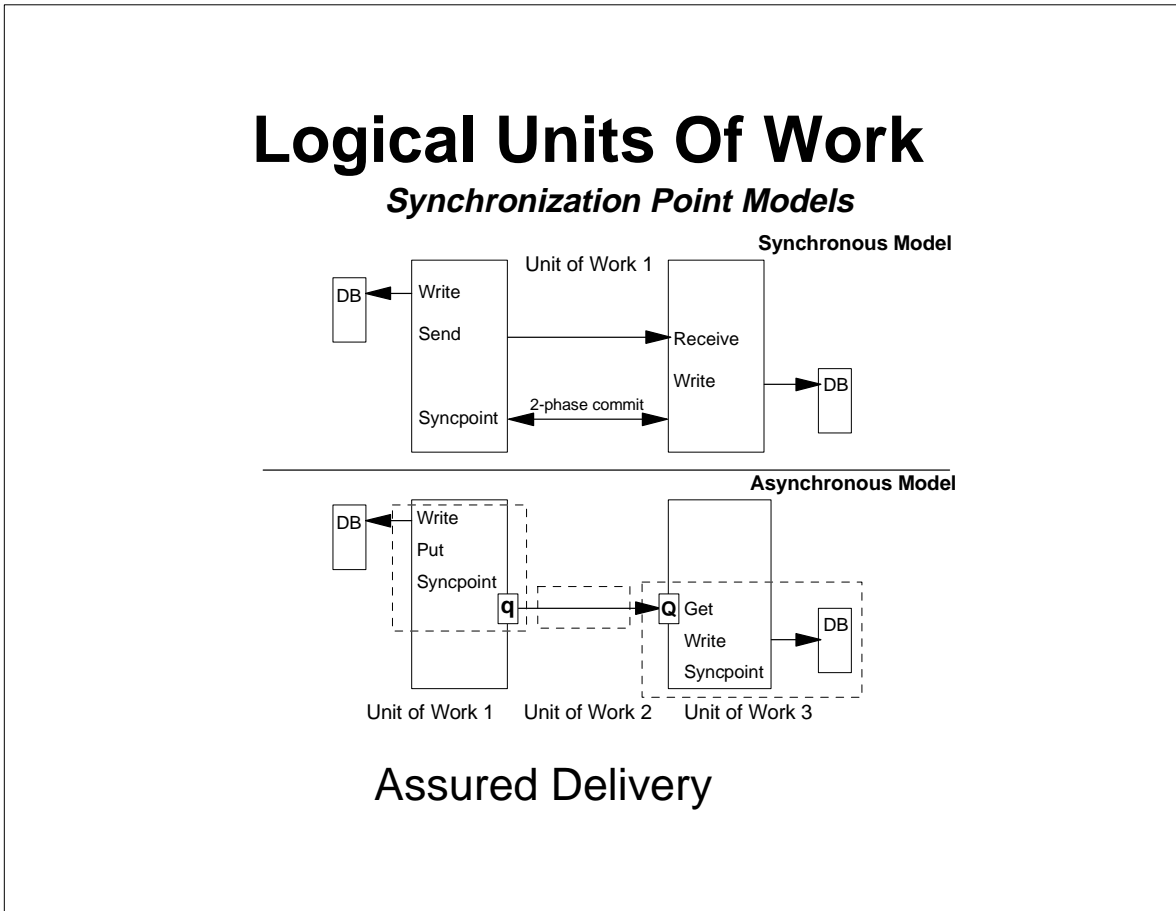
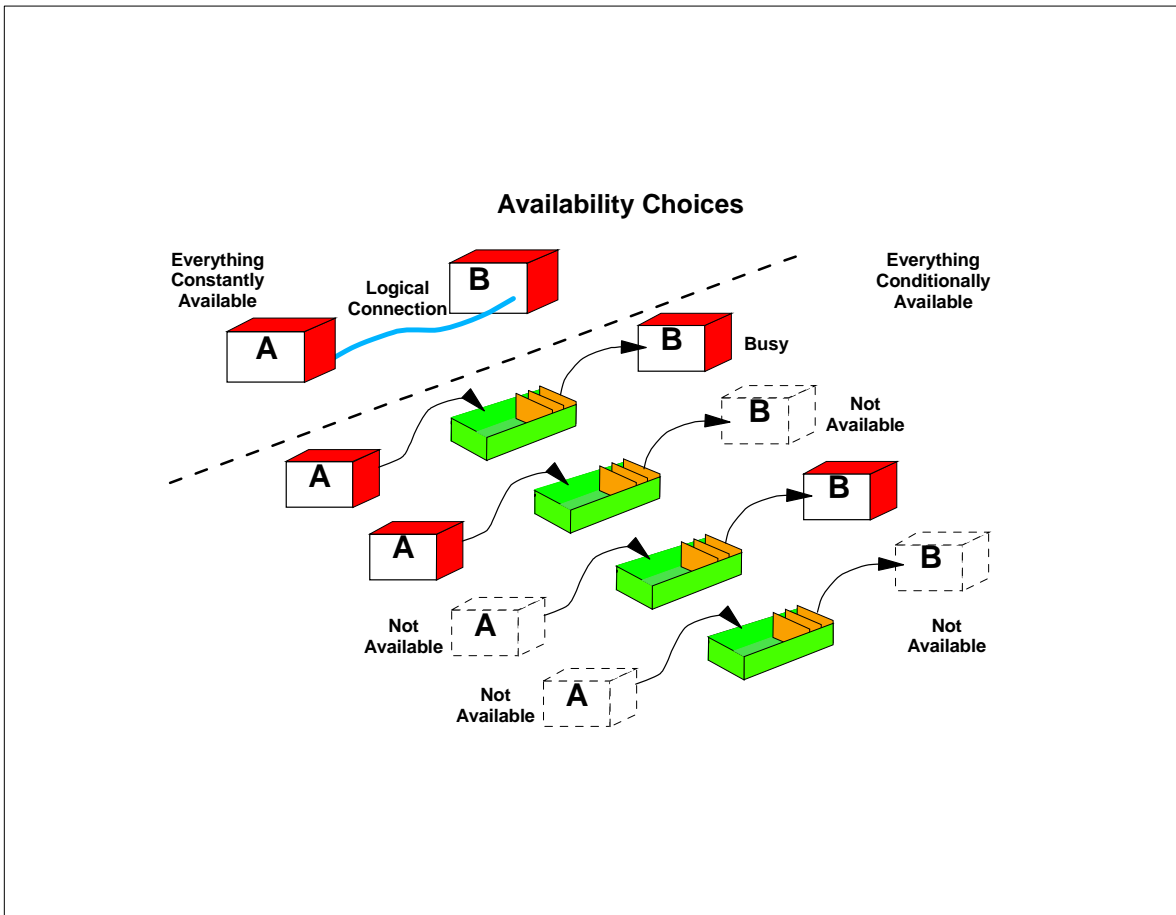

MQSeries

- MQ is accessed by 'CALL'
Verb set is: OPEN, CLOSE, GET, PUT....
- Languages include COBOL, PL/1, ALC, C, C++, and REXX (depending on platform)
- Supports access over TCP/IP or SNA without coding TCP or SNA in your application.
- Assures delivery of messages, and recovers messages from system failures.
- Works with or without transaction managers.

MQ API

The MQI API

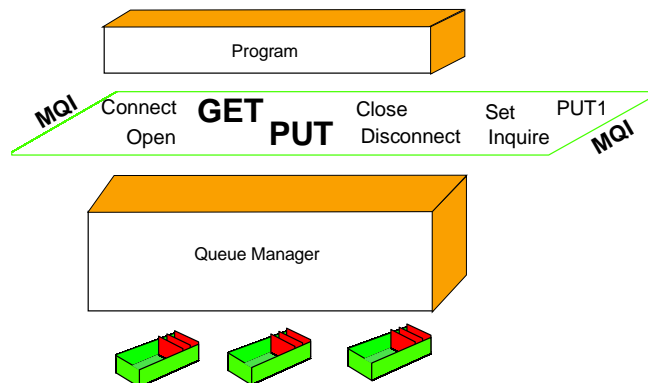

Message Layout

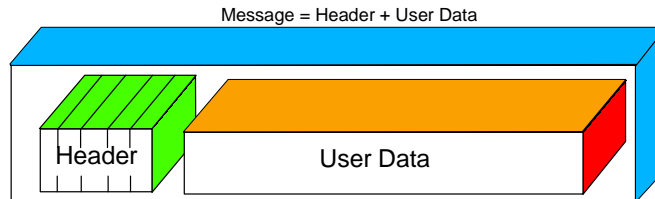

A Series of Message Attributes
Understood and augmented by the Queue Manager

- Target queue name
- Length of user data
- Message priority
- Reply-to queue name
- Context
-etc.

Any sequence of bytes

- Private to the sending and receiving programs
- Not meaningful to the Queue Manager

Business Advantages of MQSeries Products

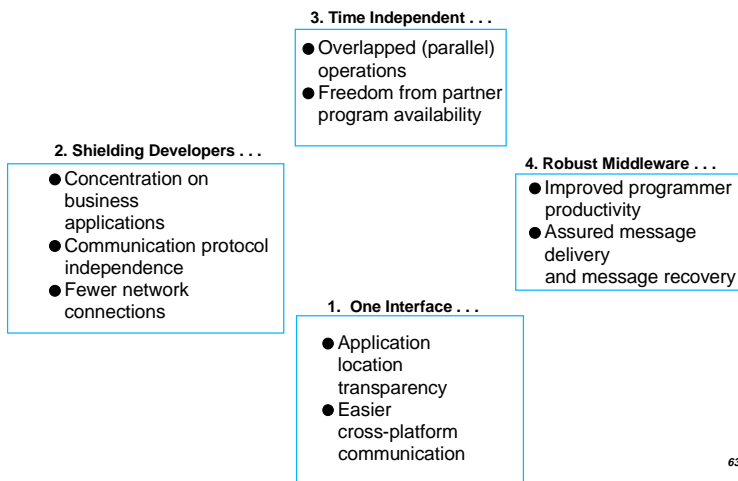

630

Policy Booking

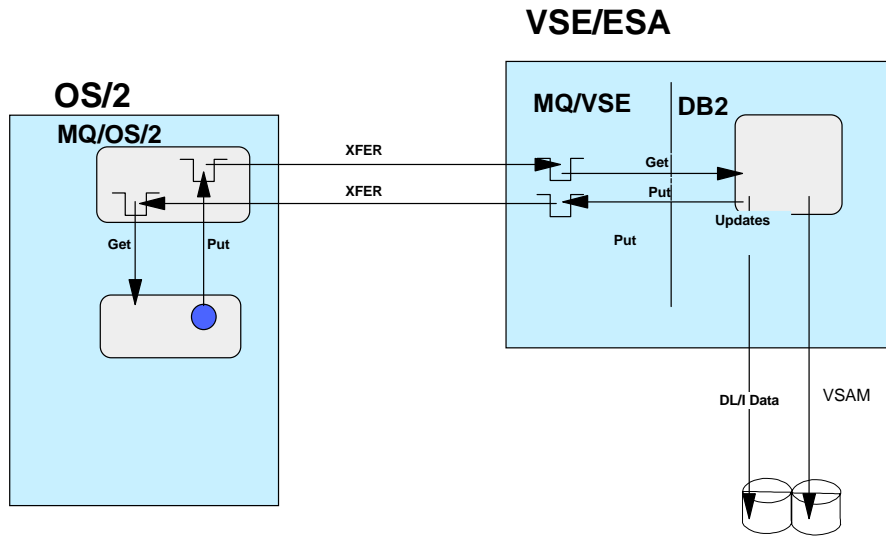

Workstation does not require CICS
Messages XFERed by MQSeries

MQSeries in Finance

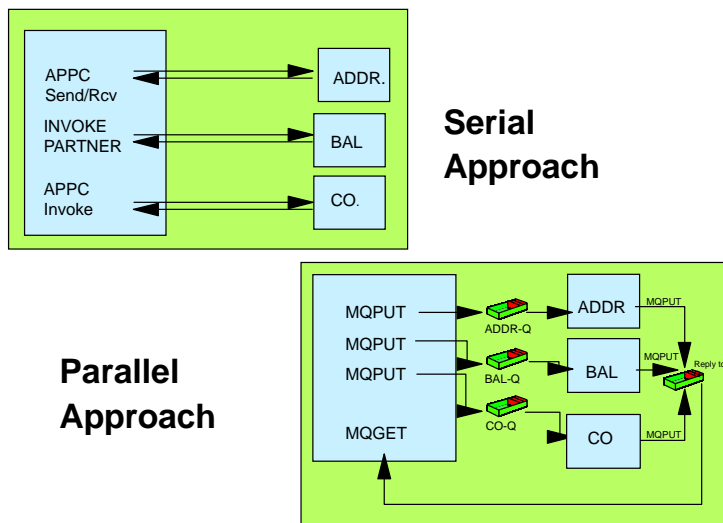

Application Integration

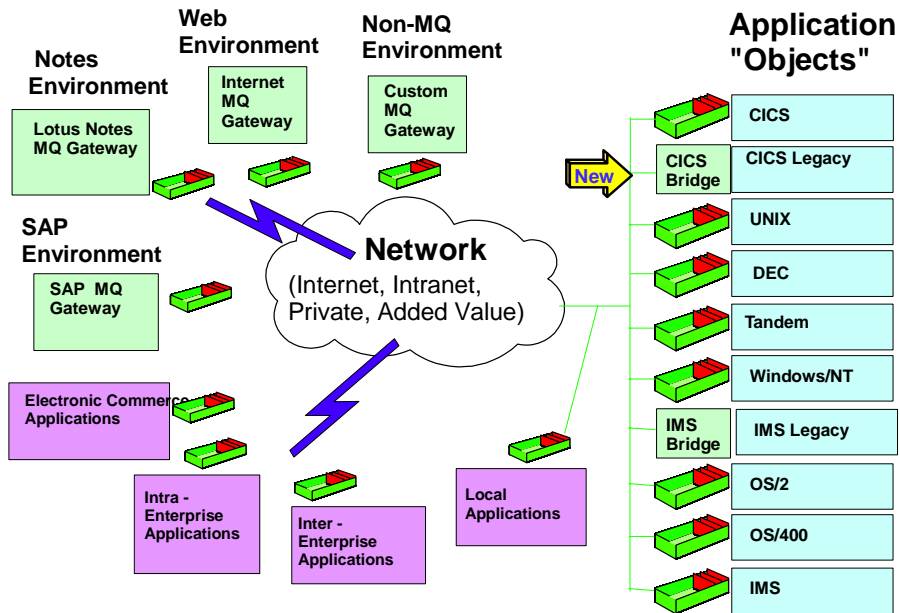

MQSeries for VSE/ESA 2.1

MQSeries and CICS

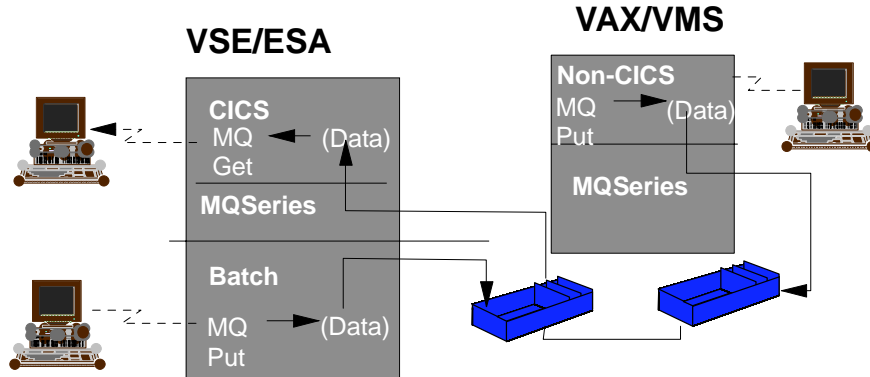

- Gives CICS Access to Messages From:
 - Other Platforms outside VSE
 - Batch programs in VSE
- Allows other Platforms access to CICS without using CICS API

What's new in 2.1? (1)

- TCP/IP support - in addition to SNA LU6.2 support
- Client support - now acts as a server product
- Non-persistent messages - now supported in addition to persistent messages
- Report messages - give information about other messages: confirm on arrival, confirm on delivery
- Larger messages - now supports messages up to 4Mb instead of the previous limit of 30K bytes

What's new in 2.1? (2)

- Improved API support - more options available, for example, MsgID/CorrelID is now supported on MQPUT and MQGET, MQSET support
- Message priority - can now be assigned by the sending application
- Large batch size - no longer a limit on transmit batch size, become a user specified option
- PL/I and C support in addition to Cobol support

What's new in 2.1? (3)

- Reusable file storage system - now an automated procedure for queue file reorganization. Operator no longer required to close MQ queues and VSAM files to recover space
- Code page support now a user-definable item
- Improved Communication Error Handling for sender and receiver channel agents (MCAs)

MQ/VSE Trends and Directions

- Scripts
- Channel Exits
- Programmable Command Format (PCF)

MQSeries and the Internet

Internet Gateway

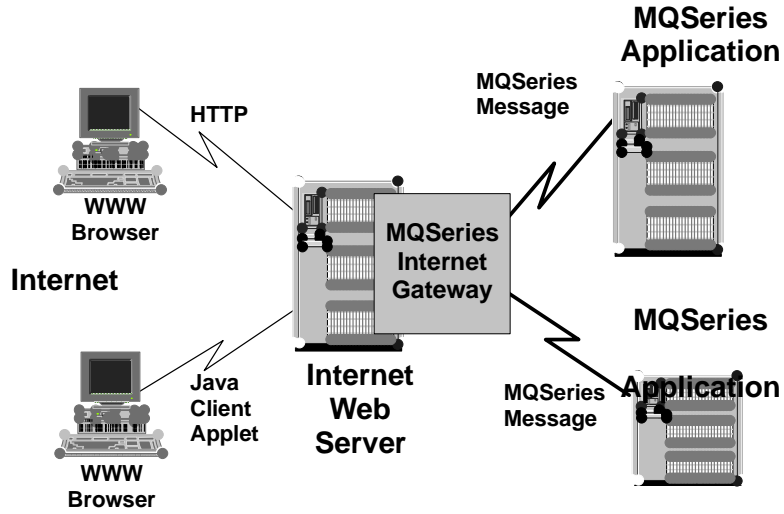

MQSeries Java Client

Thin client - tackles cost of ownership

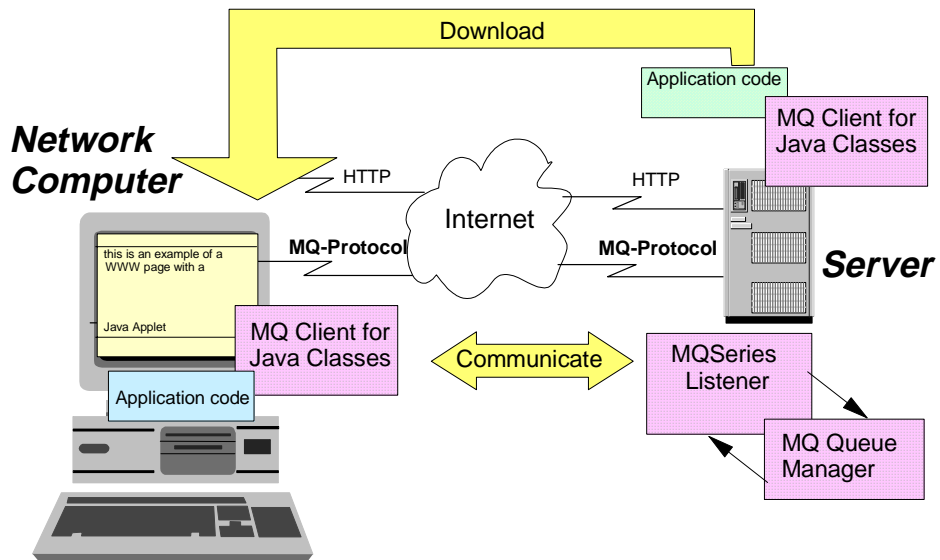

Passing HTML to Host

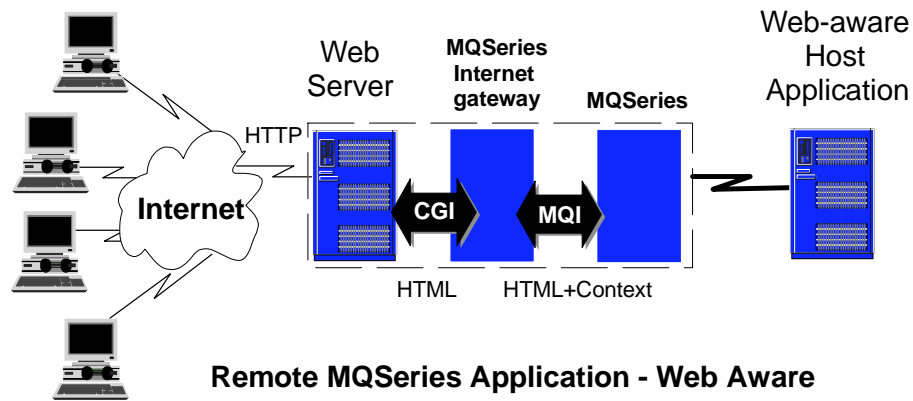

Remote MQSeries Application - Web Aware

No application code on Web Server

MQSeries on the WWW

Benefits MQSeries brings to WWW

- **Asynchronous (Offline) Processing**
- **Assured Delivery**
- **Transactional Message Support**
- **Convenient programming environment**
- **Isolation of internal networks from Internet**
- **Bridge to non-IP networks**
- **Support for parallelism**

MQSeries EveryPlace

MQSeries Everyplace Solutions

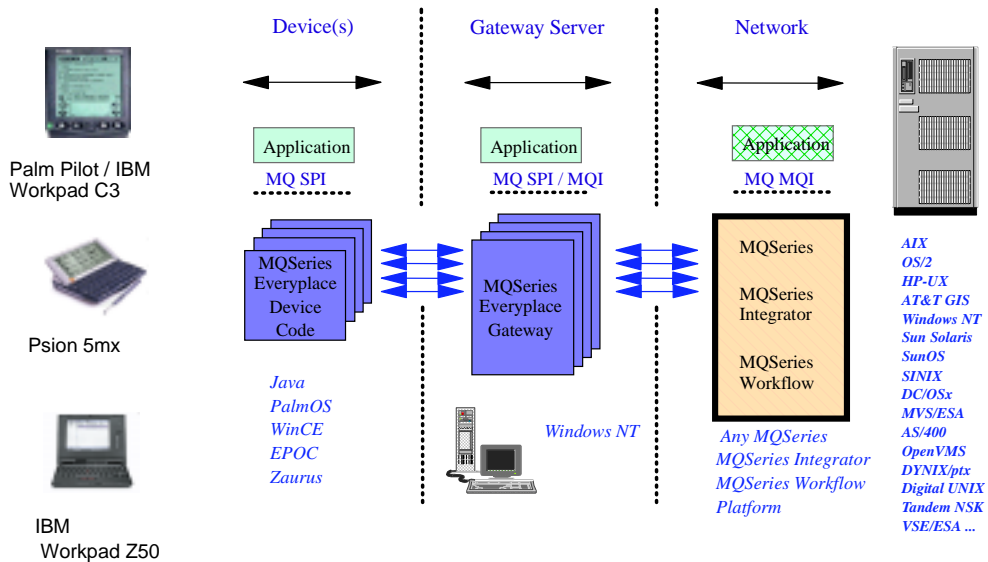

Examples of Types of Devices

Horizontal Device Market ← → Vertical Device Market

"Bread and butter of wireless in the past has been vertical applications in areas such as field service, couriers, transportation, utility companies, and police department. Common characteristics of these groups are time-sensitivity, geographical ubiquity." (Zona Research).



Thinkpad



**PDA with keyboard
Psion (EPOC)
Sharp (Synergy)
WinCE devices**

**PDA with stylus
Palm
WinCE**



**Mobile phone
Nokia 9000i**



PDA = Personal Digital Assistant

Possible Users of MQSeries Everywhere



Telephone-connected

Sales person with PDA can dial into office to place order using MQSeries network.



Executive with Thinkpad receives high-priority messages or approves high-value transactions.

Mobile phone



Mobile workers track progress and receive up-to-the-minute information. Can request more details or ask for assistance.



Delivery driver gets new pick-ups and records deliveries or they record themselves.



Home user can order shopping or shares via the Internet.



Efficient, reliable delivery of information to and from vehicles

MQSeries and LOTUS

MQSeries link for Lotus Notes

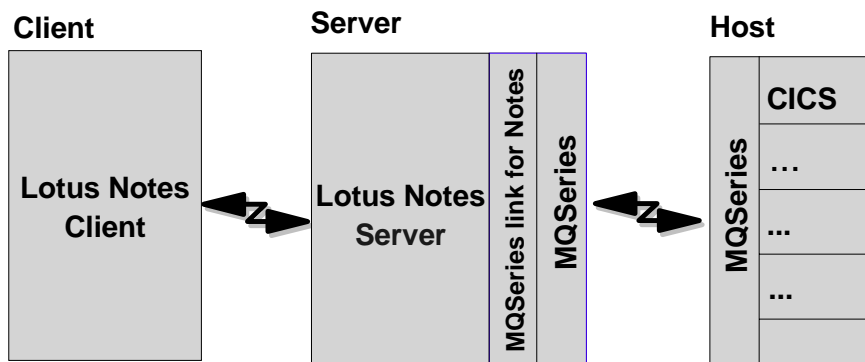

OS2 AIX NT SUN HP

MQSeries and SAP R/3

SAP R3 and MQSeries Products

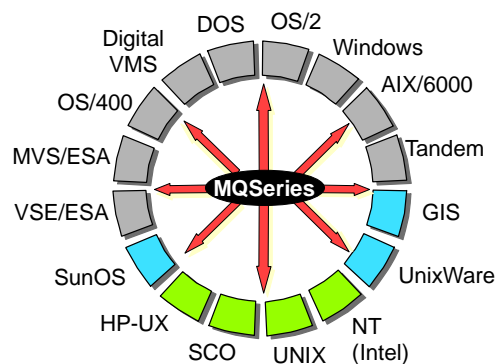
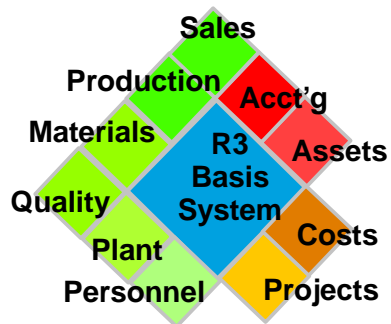

Requirements

- Communication between R/3 and other systems
- Standardised communication between R/3 systems
- One carrier system for all asynchronous communication
- Reliable messaging system with advanced communication features
- Transparent to R/3 and ABAP/4 applications
- R/3 Link Support for the following platforms: AIX, HP-UX, AS/400, Win NT, Sun Solaris, and Compaq Tru64 UNIX

MQSeries and ALE provide the solution

SAP R/3 ALE with MQSeries

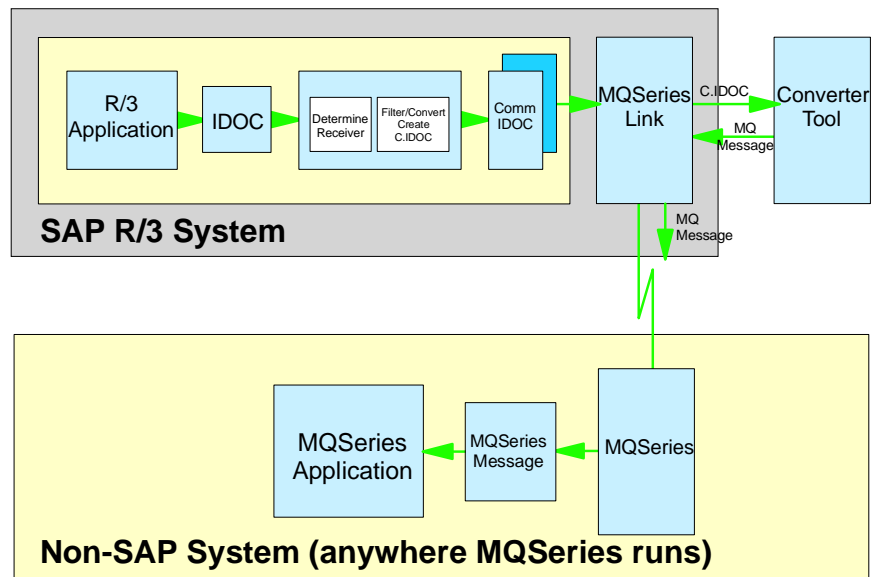

Appendix

Additional MQSeries Information

MQSeries Concepts and Architecture	GC33-1141
MQSeries for VSE/ESA	SG24-5647
e-business Solutions for VSE/ESA	SG24-5662
IBM MQSeries for VSE/ESA User's Guide	SC33-1142
An Introduction to Messaging and Queuing	GC33-0805
MQSeries Planning Guide	GC33-1349
MQSeries Intercommunication	SC33-1872
MQSeries Clients	GC33-1632
http://www.software.ibm.com/ts/mqseries	
http://www.software.ibm.com/mqseries/mq/	

MQSeries for VSE/ESA 2.1

Software Requirements

- VSE/ESA 2.3 or VSE/ESA 2.4
- CICS/VSE 2.3 or CICS TS for VSE
- VTAM for VSE/ESA 4.2 +
- TCP/IP for VSE/ESA 1.3
- LE/VSE 1.4 runtime library
- The following application languages are supported
 - ▶ C for VSE
 - ▶ PL/1 for VSE
 - ▶ COBOL for VSE

MQSeries for VM Client

Software Requirements

- **VM/ESA V2 R2.0 or higher**
- **LE/370 Release 1.6**
- **C for VM Release 3.1 or compatible product**
- **TCP/IP Release 2.4 or VTAM**

- **The following application languages are supported**
 - ▶ **IBM C for VM Release 3.1**
 - ▶ **IBM VS Cobol II**
 - ▶ **IBM OS/PLI Release 2.3**
 - ▶ **REXX**
 - ▶ **IBM Assembler**

MQSeries for Linux

Software Requirements

- **Linux kernel 2.2.5 or higher**
- **glibc V2.0.7 or higher**
- **pthread V0.7 or higher**
- **libstdc++ V2.8.0 or higher**
- **Red Hat Package Manager for installation**
- **Apache Web Server 1.3**

- **Languages, Compilers and Development Environment**
 - ▶ **MQI C and C++ libraries are provided**
 - **gcc and g++ compilers**
 - ▶ **Support for non-threaded and threaded clients and local applications**
- **TCP/IP network protocol only**

MQSeries Everyplace

- Supports Windows CE, EPOC, Palm OS and Windows 32-bit operating systems via wireless (or wired) connection
- Enables devices such as personal digital assistants (PDAs) to exchange information via gateways and to and from back-end servers, including legacy enterprise systems
- Expected to start at 50K-100K bytes in size; could be embedded in the devices.
- Will support Java, the C and C++ programming languages (depending on platform), and TCP/IP and HTTP protocols.
- Lightweight extension to MQSeries
- Has options for data encryption and qualities of service.

Web Browsers vs. MQSeries Everyplace

Web Browsers

- Good for WWW browsing
- Security options available
- **but...**
- Cannot tolerate intermittent failures or disconnection
- Can leave data locked during disconnection
- Uses inefficient data streams
- Must send display data and programs out as well as good data in
- Needs gateway for back-end connection

MQSeries Everyplace

- Tolerant of intermittent failures
- Suitable for disconnected use
- Assured delivery avoids data loss and open locks
- Efficient data compression
- High security available
- Sends only good data as needed by the application
- Suitable for machine-to-machine communication
- Can send messages directly to several back-end hosts at once
- Can connect to legacy applications

